

**UNITED STATES  
 SECURITIES AND EXCHANGE COMMISSION  
 Washington, D.C. 20549**

**AMENDMENT NO. 1 TO  
 FORM S-1  
 REGISTRATION STATEMENT  
 UNDER  
 THE SECURITIES ACT OF 1933**

**Sun Country Airlines Holdings, Inc.**  
 (Exact name of registrant as specified in its charter)

**Delaware**  
 (State or Other Jurisdiction of  
 Incorporation or Organization)

**4512**  
 (Primary Standard Industrial  
 Classification Code Number)  
 2005 Cargo Road  
 Minneapolis, MN 55450  
 (651) 681-3900

**82-4092570**  
 (I.R.S. Employer  
 Identification Number)

(Address, Including Zip Code, and Telephone Number, Including Area Code, of Registrant's Principal Executive Offices)

Eric Levenhagen, Esq.  
 General Counsel and Secretary  
 2005 Cargo Road  
 Minneapolis, MN 55450  
 (651) 681-3900

(Name, Address, Including Zip Code, and Telephone Number, Including Area Code, of Agent For Service)

*Copies to:*

**Brian M. Janson, Esq.**  
 Paul, Weiss, Rifkind, Wharton &  
 Garrison LLP  
 1285 Avenue of the Americas  
 New York, NY 10019-6064  
 (212) 373-3000

Eric Levenhagen, Esq.  
 General Counsel and Secretary  
 2005 Cargo Road  
 Minneapolis, MN 55450  
 (651) 681-3900

**Michael Kaplan, Esq.**  
 Derek Dostal, Esq.  
 Davis Polk & Wardwell LLP  
 450 Lexington Avenue  
 New York, NY 10017  
 (212) 450-4000

Approximate date of commencement of proposed sale to the public: As soon as practicable after the effective date of this registration statement.

If any of the securities being registered on this Form are to be offered on a delayed or continuous basis pursuant to Rule 415 under the Securities Act of 1933 check the following box.

If this Form is filed to register additional securities for an offering pursuant to Rule 462(b) under the Securities Act, please check the following box and list the Securities Act registration statement number of the earlier effective registration statement for the same offering.

If this Form is a post-effective amendment filed pursuant to Rule 462(c) under the Securities Act, check the following box and list the Securities Act registration statement number of the earlier effective registration statement for the same offering.

If this Form is a post-effective amendment filed pursuant to Rule 462(d) under the Securities Act, check the following box and list the Securities Act registration statement number of the earlier effective registration statement for the same offering.

Indicate by check mark whether the registrant is a large accelerated filer, an accelerated filer, a non-accelerated filer, a smaller reporting company, or an emerging growth company. See the definitions of "large accelerated filer," "accelerated filer," "smaller reporting company," and "emerging growth company" in Rule 12b-2 of the Exchange Act.

Large accelerated filer	<input type="checkbox"/>	Accelerated filer	<input type="checkbox"/>
Non-accelerated filer	<input type="checkbox"/>	Smaller reporting company	<input type="checkbox"/>
		Emerging growth company	<input checked="" type="checkbox"/>

If an emerging growth company, indicate by check mark if the registrant has elected not to use the extended transition period for complying with any new or revised financial accounting standards provided pursuant to Section 7(a)(2)(B) of the Securities Act.

**CALCULATION OF REGISTRATION FEE**

Title of each Class of Securities to be Registered	Amount to be Registered	Proposed Maximum Offering Price Per Share	Proposed Maximum Aggregate Offering Price(1)(2)	Amount of Registration Fee(3)
Common stock, par value \$0.01 per share				

- (1) Estimated solely for the purpose of calculating the registration fee pursuant to Rule 457(o) under the Securities Act of 1933, as amended.  
 (2) Includes offering price of any additional shares that the underwriters have the option to purchase, if any. See "Underwriting."  
 (3) To be paid in connection with the initial filing of the registration statement.

The registrant hereby amends this Registration Statement on such date or dates as may be necessary to delay its effective date until the registrant shall file a further amendment which specifically states that this Registration Statement shall thereafter become effective in accordance with Section 8(a) of the Securities Act of 1933 or until the Registration Statement shall become effective on such date as the Commission, acting pursuant to said Section 8(a), may determine.

## EXPLANATORY NOTE

Pursuant to the applicable provisions of the Fixing America's Surface Transportation Act, we are not required to file our consolidated financial statements (and related financial information) for the historical 2017 annual fiscal period or any interim fiscal period for 2018 or 2019 because we plan to file our consolidated financial statements (and related financial information) for the fiscal year ended December 31, 2019 in the first public filing of this registration statement. While the 2017 annual consolidated financial statements (and related financial information) and 2018 and 2019 interim consolidated financial statements (and related financial information) are otherwise required by Regulation S-X, we believe that they will not be required to be included in this registration statement at the time of the first public filing. However, we are filing our interim consolidated financial statements (and related financial information solely within the section titled "Management's Discussion and Analysis of Financial Condition and Results of Operations") for the nine months ended September 30, 2019 and 2018 to give the Staff of the Securities and Exchange Commission an opportunity to review such financial statements (and related financial information), including our accounting policies for the applicable periods, in advance of our first public filing of this registration statement, which will include our consolidated financial statements (and related financial information) for the fiscal year ended December 31, 2019.

The information in this preliminary prospectus is not complete and may be changed. Neither we nor the selling stockholder may sell these securities until the registration statement filed with the Securities and Exchange Commission is effective. This preliminary prospectus is not an offer to sell these securities and it is not soliciting an offer to buy these securities in any jurisdiction where the offer or sale is not permitted.

Subject to completion, dated February 5, 2020

PROSPECTUS

Shares



Sun Country Airlines Holdings, Inc.

Common Stock

This is the initial public offering of shares of common stock of Sun Country Airlines Holdings, Inc., a Delaware corporation. We are offering \_\_\_\_\_ shares of common stock and the selling stockholder identified in this prospectus is offering \_\_\_\_\_ shares of common stock. We will not receive any of the proceeds from the sale of shares of common stock offered by the selling stockholder.

We expect the public offering price to be between \$ \_\_\_\_\_ and \$ \_\_\_\_\_ per share. Prior to this offering, there has been no public market for our common stock. We intend to apply to list our common stock on the New York Stock Exchange (the “NYSE”) under the symbol “SNCY.”

SCA Horus Holdings, LLC (the “Apollo Stockholder”), which is an affiliate of certain investment funds managed by affiliates of Apollo Global Management, Inc., is currently our majority stockholder and is also the selling stockholder in this offering. Following the completion of this offering and related transactions, the Apollo Stockholder will continue to own a majority of the voting power of our outstanding common stock. As a result, we expect to be a “controlled company” under the corporate governance rules for NYSE-listed companies and will be exempt from certain corporate governance requirements of such rules. See “Risk Factors—Risks Related to this Offering and Ownership of our Common Stock,” “Management—Controlled Company” and “Principal and Selling Stockholders.”

We are also an “emerging growth company” as defined in the Jumpstart Our Business Startups Act of 2012 and are eligible for reduced public company reporting requirements. Please see “Prospectus Summary—Implications of Being an Emerging Growth Company.”

By participating in this offering, you are representing that you are a citizen of the United States, as defined in 49 U.S.C. § 40102(a)(15). See “Description of Capital Stock—Limited Ownership and Voting by Foreign Owners.”

Investing in our common stock involves risks that are described in the “Risk Factors” section beginning on page 22 of this prospectus.

	Per Share	Total
Public offering price	\$ _____	\$ _____
Underwriting discounts and commissions(1)	\$ _____	\$ _____
Proceeds to us, before expenses	\$ _____	\$ _____
Proceeds to the selling stockholder, before expenses	\$ _____	\$ _____

(1) See “Underwriting” for additional information regarding the underwriters’ compensation and reimbursement of expenses.

The underwriters may also exercise their option to purchase up to an additional \_\_\_\_\_ shares from the selling stockholder at the public offering price, less underwriting discounts and commissions, for 30 days after the date of this prospectus.

Neither the Securities and Exchange Commission nor any state securities commission has approved or disapproved of these securities or determined if this prospectus is truthful or complete. Any representation to the contrary is a criminal offense.

The underwriters expect to deliver the shares of common stock against payment on or about \_\_\_\_\_, 2020.

Barclays

The date of this prospectus is \_\_\_\_\_, 2020



**Low fares. Nonstop.**

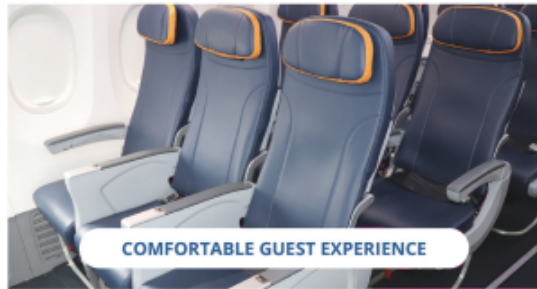



## [Table of Contents](#)

For investors outside the United States: none of us, the selling stockholder or the underwriters have done anything that would permit this offering or possession or distribution of this prospectus or any free writing prospectus we may provide to you in connection with this offering in any jurisdiction where action for that purpose is required, other than in the United States. You are required to inform yourselves about and to observe any restrictions relating to this offering and the distribution of this prospectus and any such free writing prospectus outside of the United States.

### TABLE OF CONTENTS

<a href="#">Prospectus Summary</a>	1
<a href="#">Risk Factors</a>	22
<a href="#">Cautionary Note Regarding Forward-Looking Statements</a>	54
<a href="#">Use of Proceeds</a>	56
<a href="#">Dividend Policy</a>	57
<a href="#">Capitalization</a>	58
<a href="#">Dilution</a>	59
<a href="#">Selected Historical Consolidated Financial Data</a>	62
<a href="#">Management's Discussion and Analysis of Financial Condition and Results of Operations</a>	64
<a href="#">Industry</a>	98
<a href="#">Business</a>	100
<a href="#">Management</a>	119
<a href="#">Executive Compensation</a>	127
<a href="#">Certain Relationships and Related Party Transactions</a>	139
<a href="#">Principal and Selling Stockholders</a>	142
<a href="#">Description of Capital Stock</a>	143
<a href="#">Shares Eligible for Future Sale</a>	151
<a href="#">Material U.S. Federal Income Tax Considerations</a>	153
<a href="#">Underwriting</a>	157
<a href="#">Legal Matters</a>	163
<a href="#">Experts</a>	163
<a href="#">Where You Can Find More Information</a>	163
<a href="#">Index to Consolidated Financial Statements</a>	F-1

None of us, the selling stockholder or the underwriters have authorized any other person to provide you with any information or to make any representations other than those contained in this prospectus or in any free writing prospectuses we have prepared. We, the selling stockholder and the underwriters take no responsibility for, and can provide no assurance as to the reliability of, any other information that others may provide you. We and the selling stockholder are offering to sell, and seeking offers to buy, shares of common stock only in jurisdictions where offers and sales are permitted. You should assume that the information appearing in this prospectus is accurate only as of the date of this prospectus, regardless of the time of delivery of this prospectus or of any sale of the common stock. Our business, financial condition, results of operations and prospects may have changed since that date.

Through and including \_\_\_\_\_, 2020 (the 25th day after the date of this prospectus), all dealers effecting transactions in the common stock, whether or not participating in this offering, may be required to deliver a prospectus. This delivery requirement is in addition to a dealer's obligation to deliver a prospectus when acting as an underwriter and with respect to an unsold allotment or subscription.

## TRADEMARKS, TRADE NAMES, AND SERVICE MARKS

We use various trademarks, trade names and service marks in our business, including “Sun Country,” “Sun Country Airlines,” “Sun Country Connections,” “Sun Country Rewards,” “Sun Country Vacations,” “Get To Going,” “The Hometown Airline” and “UFLY,” as well as our signature “S” logo. This prospectus contains references to our trademarks, trade names and service marks. Solely for convenience, trademarks and trade names referred to in this prospectus may appear without the ® or TM symbols, but such references are not intended to indicate, in any way, that we will not assert, to the fullest extent under applicable law, our rights or the rights of the applicable licensor to these trademarks and trade names. We do not intend our use or display of other companies’ trade names, trademarks or service marks to imply a relationship with, or endorsement or sponsorship of us by, any other companies.

## INDUSTRY AND MARKET DATA

We include in this prospectus statements regarding our industry, our competitors and factors that have impacted our and our customers’ industries. Such statements are statements of belief and are based on industry data and forecasts that we have obtained from industry publications and surveys, including those published by the United States Department of Transportation, as well as internal company sources. Industry publications, surveys and forecasts generally state that the information contained therein has been obtained from sources believed to be reliable, but there can be no assurance as to the accuracy or completeness of such information. In addition, while we believe that the industry information included herein is generally reliable, such information is inherently imprecise. Certain statements regarding our competitors are based on publicly available information, including filings with the Securities and Exchange Commission and United States Department of Transportation by such competitors, published industry sources and management estimates. While we are not aware of any misstatements regarding the industry, competitor and market data presented herein, our estimates involve risks and uncertainties and are subject to change based on various factors, including those discussed under the caption “*Risk Factors*” in this prospectus.

## BASIS OF PRESENTATION

In this prospectus, unless otherwise indicated or the context otherwise requires, references to the “Company,” the “Issuer,” “Sun Country,” “we,” “us” and “our” refer, prior to our conversion to a corporation, to SCA Acquisition Holdings, LLC and its consolidated subsidiaries and, after our conversion to a corporation, to Sun Country Airlines Holdings, Inc. and its consolidated subsidiaries. See “*Prospectus Summary—The Reorganization Transactions*.”

On April 11, 2018, MN Airlines, LLC (d/b/a Sun Country Airlines and now known as Sun Country, Inc.) was acquired by certain investment funds (the “Apollo Funds”) managed by affiliates of Apollo Global Management, Inc. (together with its subsidiaries, “Apollo”). As a result of the change of control, the acquisition was accounted for as a business combination using the acquisition method of accounting, which requires, among other things, that our assets and liabilities be recognized on the consolidated balance sheet at their fair value as of the acquisition date. Accordingly, the financial information provided in this prospectus is presented as “Predecessor” or “Successor” to indicate whether they relate to the period preceding the acquisition or the period succeeding the acquisition, respectively. Due to the change in the basis of accounting resulting from the acquisition, the consolidated financial statements for the Predecessor and Successor periods, included elsewhere in this prospectus, are not necessarily comparable.

All consolidated financial statements presented in this prospectus have been prepared in U.S. dollars in accordance with generally accepted accounting principles in the United States of America (“GAAP”).

## PROSPECTUS SUMMARY

*The following summary contains selected information about us and about this offering. It does not contain all of the information that is important to you and your investment decision. Before you make an investment decision, you should review this prospectus in its entirety, including matters set forth under “Risk Factors,” “Management’s Discussion and Analysis of Financial Condition and Results of Operations” and our consolidated financial statements and the related notes thereto included elsewhere in this prospectus. Some of the statements in the following summary constitute forward-looking statements. See “Cautionary Note Regarding Forward-Looking Statements.” For definitions of certain industry terms used in this prospectus, see “—Glossary of Terms” beginning on page 18.*

### Overview

Sun Country Airlines is a Minnesota-based high-growth, low-cost air carrier focused on serving leisure passengers on flights throughout the United States and to destinations in Mexico, Central America, the Caribbean and Canada. We operate an agile network that includes both our core scheduled service business and our synergistic and profitable charter business. Our model dynamically deploys shared aircraft and flight crews across our service lines with the objective of generating higher returns and margins. We optimize capacity allocation by market, time of year, day of week and line of business by shifting flying to markets during periods of high demand and away from markets during periods of low demand with far greater frequency than other airlines other than Allegiant Travel Company. However, unlike us, Allegiant Travel Company flies to different markets than we do with a basic product, smaller charter business and limited ticket distribution network through its website. Our model includes many of the low-cost structure characteristics of ultra low-cost carriers, or ULCCs (which include Allegiant Travel Company, Spirit Airlines and Frontier Airlines), such as an unbundled product (which means we offer a base fare and allow customers to purchase ancillary products and services for an additional fee), point-to-point service and a single-family fleet of Boeing 737-NG aircraft, which allow us to maintain a cost base comparable to these ULCCs. However, we offer an elevated product that we believe is superior to the ULCCs and consistent with that of low-cost carriers, or LCCs (which include Southwest Airlines and JetBlue Airways). For example, our product includes more legroom than ULCCs, free beverages, in-flight entertainment and in-seat power, none of which are offered by the ULCCs. The combination of our agile “peak demand” network with our elevated consumer product allows us to generate higher total revenue per available seat mile, or TRASM, than ULCCs while maintaining lower cost per available seat mile excluding fuel and certain commissions and other costs of selling our vacations product, or CASM ex, than LCCs. As a result of our complementary scheduled service, charter and future cargo businesses, agile “peak demand” network and low-cost structure similar to ULCCs and elevated consumer product similar to LCCs, we believe that Sun Country Airlines represents a new breed of hybrid air carrier.

In April 2018, we were acquired by the Apollo Funds. Since the acquisition, we have transformed our business under a new management team of seasoned professionals who have a strong combination of low-cost and legacy network airline experience. We have redesigned our network to focus our flying on peak demand opportunities at both our Minneapolis/St. Paul, or MSP, hub and our growing network of non-MSP point-to-point markets, which has supported a 43% increase in passengers from 2017 to 2019. We have greatly expanded our ancillary products and services, increasing average ancillary revenue per scheduled service passenger by over % from 2017 to 2019. Since 2017, management has taken actions to reduce our cost basis by approximately \$34 million on an annual basis, contributing to a reduction in CASM ex of over % between 2017 and 2019. We have invested over \$115 million in new aircraft, new interiors, information technology systems and other growth-oriented capital expenditure projects since the beginning of 2017. In June 2019, we introduced a new website and replaced our reservation and distribution system with the *Navitaire* system, which has lowered our selling costs, increased the proportion of our bookings that are made directly through our website and simplified the process of buying tickets and changing flight details post-purchase. We believe that these investments have

positioned us to profitably grow our business in the long term and that our period of heavy investment in transformative capital spending is behind us for the foreseeable future.

Our network transformation has focused on increasing routes flown while allocating our assets to the most profitable lines of flying. We concentrate scheduled service trips during the highest yielding months of the year and days of the week, and we allocate aircraft to our charter service when it is more profitable to do so. As a result, in 2019 only 3% of our routes were daily year-round. Although this scheduling approach results in lower fleet utilization, it generates higher TRASM than our ULCC competitors. In addition to network changes, we have invested in new aircraft interiors, including the removal of a legacy first class section and the replacement of older seats on all of our 737-800 aircraft with new comfortable reclining seats. We have increased the average seat count on our 737-800s from 162 to 186 while still offering an average pitch, which is defined as the distance from the back of a seat to the back of the seat directly in front of it, of approximately 31 inches, which is comparable legroom to Southwest Airlines and greater legroom than all of our ULCC competitors. We have also installed in-seat power and provide complimentary in-flight entertainment streamed to passengers' devices, features that are comparable to those offered by our LCC competitors and that are not offered by any of our ULCC competitors, providing our passengers with a preferred onboard experience. As part of our transformation, we have greatly increased our level of ancillary product sales, which consist of baggage fees, seat assignment fees and other fees. Our dynamic scheduling strategy, quality product and focus on ancillary revenue generation have allowed us to produce unit revenue, as measured by TRASM, of \_\_\_\_\_ cents for the year ended December 31, 2019, which is comparable to LCCs and higher than ULCCs.

Our business transformation has also focused heavily on unit cost reduction. We have achieved cost savings by renegotiating certain key contracts and agreements, outsourcing certain functions to third-party service providers, reducing the cost of our fleet through more efficient aircraft sourcing and financing, staffing efficiencies and other cost-saving initiatives. As a result of these savings and the seat densification of our aircraft, our CASM ex has decreased from 7.79 cents for the year ended December 31, 2017 to \_\_\_\_\_ cents for the year ended December 31, 2019. Our CASM ex for the year ended December 31, 2019 is comparable to ULCCs and lower than LCCs. We believe that we are well-positioned to continue reducing our unit costs as we grow through ongoing strategic initiatives and as we realize greater economies of scale. In addition, we believe that low cost, leisure focused business models similar to ours have been more resilient during economic downturns compared to business models adopted by legacy network airlines.

Our transformation has resulted in rapid growth and significant improvements to our financial results. From 2017 to 2019, our average fleet count has increased from 23.4 to 28.4 aircraft, our available seat miles have increased by approximately 35% and our revenue has increased by approximately \_\_\_\_%. In 2019, our total revenue was approximately \$ \_\_\_\_\_ million, our net income was approximately \$ \_\_\_\_\_ million, our Adjusted Net Income was approximately \$ \_\_\_\_\_ million, our Adjusted EBITDAR was approximately \$ \_\_\_\_\_ million and we had positive free cash flow, which we define as operating cash flow minus capital expenditures.

#### ***Our New Air Cargo Services Contract with Amazon***

On December 13, 2019, we signed a six-year contract (with two, two-year extension options, for a maximum term of 10 years), which we refer to as the "ATSA," with Amazon.com Services, Inc. (together with its affiliates, "Amazon") to provide them with air cargo services. Flying under the ATSA is expected to begin in the second quarter of 2020 and be fully ramped up by the fourth quarter of 2020, at which point Amazon will have up to 10 Boeing 737-800 cargo aircraft flown by Sun Country. We expect this new business will enable us to leverage certain assets, capabilities and fixed costs to enhance profitability and promote growth. For example, we believe that by deploying pilots across each of our business lines we can increase the efficiency of our operations. Moreover, our air cargo services business addresses rapidly growing demand for e-commerce air cargo solutions, which we believe represents a significant opportunity for future growth.

### Our Competitive Strengths

We believe that the following key strengths allow us to compete successfully within the U.S. airline industry.

**Agile “Peak Demand” Scheduling Strategy.** We flex our capacity by day of the week, month of the year and line of business to capture what we believe are the most profitable flying opportunities available from both our MSP home market and our growing network of non-MSP markets. As a result, our route network varies widely throughout the year. For the year ended December 31, 2019, we flew approximately 38% of our ASMs during our top 100 peak demand days of the year as compared to 15% of our ASMs during our bottom 100 demand days of the year. For 2019, our average fare was approximately % higher on our top 100 peak demand days as compared to the remaining days of the year. In 2019, only 3% of our routes were daily year round, compared to 8% for Frontier Airlines, 2% for Allegiant Travel Company, 42% for Spirit Airlines and 67% for Southwest Airlines. The following charts demonstrate that our schedule is highly variable by day of the week and month of the year.

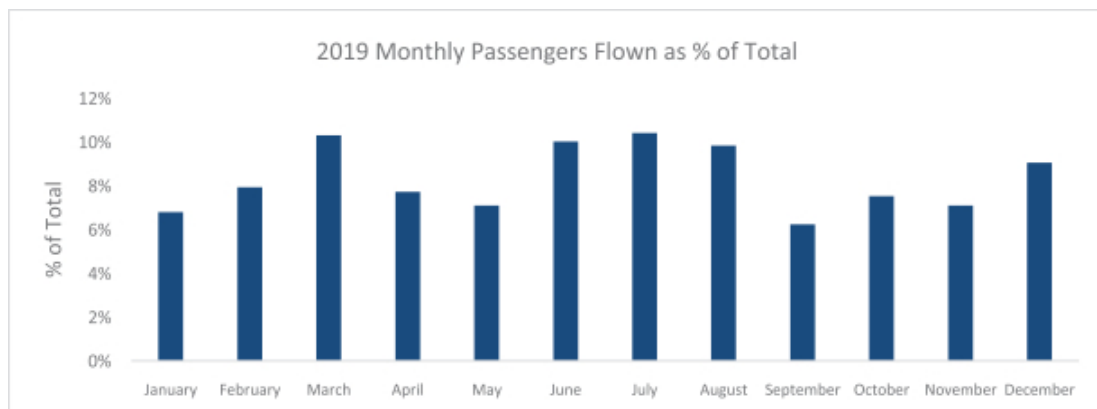
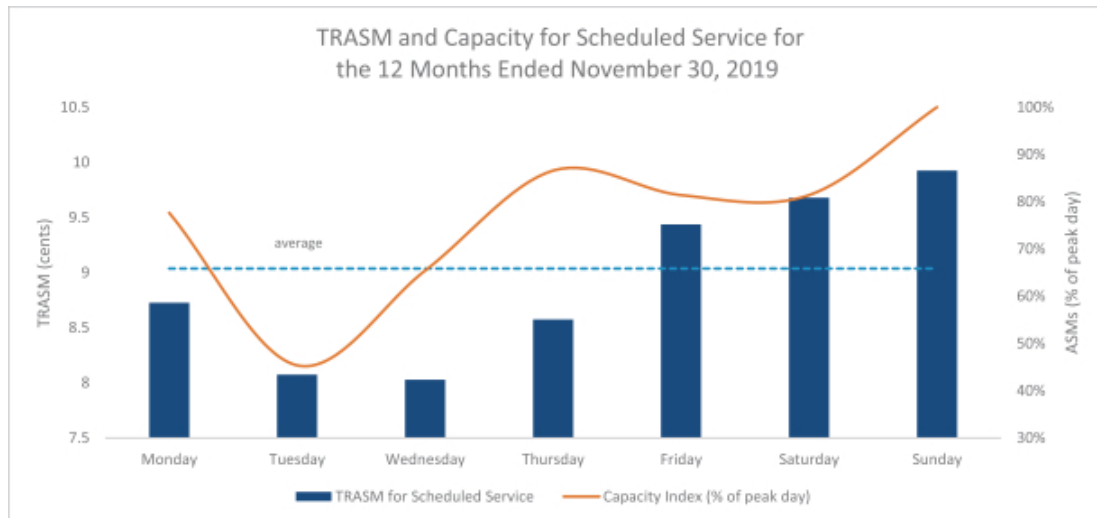

In addition to shifting aircraft across our network by season and day of week, we also shift between our scheduled service and charter businesses to maximize the return on our assets. We regularly schedule our fleet using what we refer to as “Power Patterns,” which involves scheduling aircraft and crew on trips that combine scheduled service and charter legs, dynamically replacing what would be lower margin scheduled service flights with charter

opportunities. Our agility is supported by our variable cost structure and the cross utilization of our people and assets between our lines of business. We believe that the synergies to be gained from cross utilization will increase when we begin servicing the Amazon cargo business in the second quarter of 2020 because our pilots will interchangeably be scheduled between scheduled service, charter and cargo flights. Our agile peak demand strategy allows us to generate higher TRASM by focusing on days with stronger demand.

**Tactical Mid-Life Fleet with Flexible Operations.** We maintain low aircraft ownership costs by purchasing mid-life Boeing 737-800 aircraft, which have a lower purchase price than comparable new Boeing 737-800 aircraft. This lower initial price generates the most significant cost advantage in our fleet strategy. Older aircraft on average require higher ongoing maintenance and repair costs, although the cyclical nature of airframe and engine maintenance intervals results in varying annual expenses that are not directly correlated to the age of the aircraft. When coupled with the lower purchase price, we believe that our mid-life aircraft achieve lower cost of ownership than new aircraft. Lower ownership costs allow us to maintain lower unit costs at lower levels of utilization. This allows us to concentrate our flying during periods of peak demand, which generates higher TRASM. In 2019, we flew our aircraft an average of 9.6 hours per day, which is the lowest among major U.S. airlines other than Allegiant Travel Company, which flies a similar low utilization model but serves smaller markets. Our single family aircraft fleet also has operational and cost advantages, such as allowing for optimization of crew scheduling and training and lower maintenance costs. Our fleet is highly reliable and we have a demonstrated ability to maintain our high completion factor during harsh weather conditions. For the year ended December 31, 2019, we had a completion factor of 99.8% across our system.

**Superior Low-Cost Product and Brand.** We have invested in numerous projects to create a well-regarded product and brand that we believe is superior to ULCCs while maintaining lower fares than LCCs and larger full service carriers. Some of the reasons that we believe we have a superior brand to ULCCs include:

- **Our Cabin Experience.** We have replaced all of our 737-800 seats with new state-of-the-art seats that comfortably recline and have full size tray tables. Our new seats have an average pitch of approximately 31 inches, giving our customers comparable legroom to Southwest Airlines and greater legroom than all ULCCs in the United States. We also added seat-back power, complimentary in-flight entertainment and free beverages to improve the overall flying experience for our customers. Such amenities are comparable to those offered by our LCC competitors and are not available on any ULCCs in the United States.
- **Our Digital Experience.** We have significantly improved the buying experience for our customers. We overhauled our passenger service system and transitioned to *Navitaire*, the premier passenger service system in the United States. *Navitaire* has decreased our overall website session length, decreased the percentage of failures to complete a transaction after accessing our website on a mobile device and increased the percentage of visits to our website that result in an airfare purchase. The transition to *Navitaire* has been one of our most important initiatives, improving the Sun Country customer experience, making our website booking more seamless, allowing us to create a large customer database and supporting ancillary revenue growth.

In addition to our product, we believe that our brand is well recognized and well regarded in the markets that we serve. In the fourth quarter of 2019, management conducted a study of individuals across a variety of ages, income levels, home regions and home airports (including both MSP and non-MSP travelers), each of whom had traveled for leisure within the prior 24 months. Individuals selected for the survey included Sun Country passengers and a consumer sample provided by a third-party survey panel provider. 468 individuals responded to the study, 275 of whom had flown Sun Country Airlines. Based on that study: 79% of respondents who expressed a preference between airlines and had flown on both Sun Country Airlines and Allegiant Travel Company said they would rather fly on Sun Country Airlines; 77% of respondents who expressed a preference between airlines and had flown on both Sun Country Airlines and Frontier Airlines said they would rather fly on Sun Country Airlines; and 81% of respondents who expressed a preference between airlines and had flown on both Sun Country Airlines and Spirit Airlines said they would rather fly on Sun Country Airlines.



**Competitive Low Cost Structure.** Our transformation initiatives have reduced our unit costs significantly and have positioned us well for future growth. Since 2017, management has taken actions to reduce our cost basis by approximately \$34 million on an annual basis and has initiatives in place to generate an additional \$10 million of annual cost savings going forward. Our completed and ongoing cost savings efforts include the outsourcing of Minneapolis station handling, renegotiation of our component maintenance agreement, fuel savings initiatives, catering cost reductions, renegotiation of distribution contracts and various other initiatives. Our CASM ex has declined from 7.79 cents for the year ended December 31, 2017 to \_\_\_\_\_ cents for the year ended December 31, 2019. We are also focused on continuous cost rationalization and identifying potential redundancies or inefficiencies in our operations. We believe that our business model and strategy positions us well to maintain and improve our CASM despite having lower utilization rates than most of our peers.

**Strong Position in Our Profitable MSP Home Market.** We have been based in the Minneapolis-St. Paul area since our founding over 35 years ago, where our brand is well-known and well-liked. We are the largest low-cost carrier operating at MSP, which is our largest base, and the second largest airline based on ASMs at MSP after Delta Air Lines, which primarily serves business and connecting traffic customers, while we primarily serve leisure customers. Excluding Delta Air Lines, we have nearly twice the capacity, as measured by ASMs, of any other competitor operating at MSP. However, our seat share at MSP is still meaningfully lower than Spirit Airlines' seat share in Fort Lauderdale and Frontier Airlines' seat share in Denver, and we believe there is significant room for us to grow in MSP through further market stimulation. We fly out of Terminal 2, which we believe is preferred by many flyers because of its smaller layout, shorter security wait times, close parking relative to check-in and full suite of retail shops. We currently utilize 8 of the 14 gates in Terminal 2. As a result of our focus on flying during seasonal peak periods, our well regarded brand and product and our strong position in Minneapolis, we enjoy a TRASM premium at MSP. We believe MSP is among the most profitable LCC bases in the United States and we believe we generate higher TRASM in MSP than any ULCC in the United States in its primary base.

**Synergistic and Profitable Charter Business.** From 2017 through 2019, we have grown our charter revenue by approximately \_\_\_\_\_ % while providing charter services to over 275 destinations in 25 countries across the world. Our charter business has several favorable dynamics including a large repeat customer base, stable demand and the ability to pass through certain costs, including fuel. Our diverse charter customer base includes casino operators, the U.S. Department of Defense, college sports teams and professional sports teams. We are the primary air carrier for the NCAA Division I National Basketball Tournament (known as "March Madness") and we flew over 100 college sports teams during 2019. Our charter business includes ad hoc, repeat, short-term and long-term service contracts (with pass through fuel arrangements and annual rate escalation) and most of our business is non-cyclical because the U.S. Department of Defense and sports teams still fly during economic downturns and our casino contracts are long-term in nature. Additionally, our stable and growing charter business complements seasonal and day-of-week focused scheduled passenger service by allowing us to optimize our aircraft scheduling and crew to the most profitable flying opportunities. In general, charter available seat miles are high in fall months when scheduled service operations are less favorable.

**Seasoned Management Team.** As part of our transformation, we recruited a seasoned management team with decades of experience in aviation at some of the largest and most successful airlines in the world. Our Chief Executive Officer, Jude Bricker, joined Sun Country Airlines in July 2017 and has over 15 years of experience in the aviation industry, including serving as the Chief Operating Officer of Allegiant Travel Company from 2016 to 2017, at which point it was a public company. Our President and Chief Financial Officer, Dave Davis, joined Sun Country in April 2018 and has over 20 years of experience in the aviation industry, including previously serving as the Chief Financial Officer at Northwest Airlines and US Airways, which were both public companies. Other members of our management team have worked at airlines such as American Airlines, Delta Air Lines, Northwest Airlines and US Airways.

## Our Growth Strategy

Over the past two years, we have transformed our business to establish the infrastructure to support significant profitable growth going forward. Our main initiatives have included:

- *Network.* We launched 64 new markets and developed a repeatable network growth strategy. Our network strategy is expected to support passenger fleet growth to approximately 50 aircraft by the end of 2023.
- *Fleet.* We restructured our fleet with a focus on ownership of Boeing 737-800s with no planned lease redeliveries prior to 2024, allowing us to focus on growth with low capital commitments.
- *Customer.* We rebranded the airline around a leisure product with a significant ancillary revenue component. With the product transition complete, we can focus on stimulating demand in current and new markets and delivering a high quality travel experience.
- *Culture.* We installed a new management team with a cost-conscious ethos, which included moving our headquarters into a hangar at MSP.
- *Operations.* Through our transformation, we have maintained high standards of operational performance, including a 99.8% completion factor for the year ended December 31, 2019.

We believe our initiatives have provided us with a platform to continue to profitably grow our business. Key elements of our growth strategy include:

***Expand our “Peak Demand” Flying in Minneapolis and Beyond.*** We intend to continue to grow our network profitably both from MSP and on new routes outside of MSP by focusing on seasonal markets and day-of-the-week flying during periods of peak demand. We have expanded our network from 46 routes in 2017 to 98 routes currently planned for 2020, including expanding our routes that neither originate nor terminate in MSP from 5 routes in 2017 to 42 routes planned for 2020. We have expanded our operations aggressively in recent years, in part because we are able to efficiently redeploy assets. Furthermore, the reduction in our unit costs has expanded the number of markets that we can profitably serve. We have identified over 250 new market opportunities. We have a successful history of opening and closing stations to meet seasonal demand. Our future network plans include growing our network at our hub in Minneapolis to full potential, including adding frequencies on routes we already serve and adding new routes to leverage our large, loyal customer base in the area. Our long-term strategic plans have identified potential growth opportunities at MSP alone of 10 to 12 aircraft by the end of 2023.

We have also been rapidly growing, and expect to continue to grow, outside of MSP. Our customer friendly low fares have been well received in the upper Midwest and in large, fragmented markets elsewhere that we can profitably serve on a seasonal and/or day-of-week basis. Our upper Midwest growth is focused on cold to warm weather leisure routes from markets similar to Minneapolis, such as Madison, Wisconsin. Additionally, we have been adding capacity on large leisure trunk routes on a seasonal basis during periods when demand is high. Examples of such routes include Los Angeles to Honolulu and Dallas to Mexican beach destinations during the summer months. Our business model is ideally suited to seasonally serve these routes, which are highly profitable because fares are elevated during the months in which we fly them. Our long-term strategic plans have identified potential growth opportunities outside of MSP of 5 to 8 aircraft, as well as an additional 3 to 4 aircraft to support our charter operations, in each case, by the end of 2023.

***Continue to Increase Our Margins and Free Cash Flows.*** Since December 31, 2017, we have reduced our CASM ex from 7.79 cents to cents, a level comparable to ULCCs. When combined with our TRASM, which remains comparable to LCCs and higher than ULCCs, we generate highly competitive margins. Since 2017, management has taken actions to reduce our cost basis by approximately \$34 million on an annual basis and has initiatives in place to generate an additional \$10 million of annual cost savings going forward. Our

completed and ongoing cost savings initiatives include outsourcing of Minneapolis station handling, reworking of spare parts agreements, fuel savings initiatives, catering cost reductions, renegotiation of distribution contracts and various other initiatives. Our period of heavy investment in fleet renewal and transformative capital expenditures is largely behind us. As a result, we expect improvements in profit margins and free cash flow to support growth in the years ahead.

**Grow Our New Amazon Business.** On December 13, 2019, we signed a new six-year contract (with two, two-year extension options, for a maximum term of 10 years) with Amazon to provide air cargo transportation services with agreed pricing. Amazon will supply the aircraft and bear directly or reimburse us for certain operating expenses, including fuel and heavy maintenance. The aircraft will fly under our air carrier operating certificate and we will supply the crew, maintenance and insurance for the aircraft, all expenses that are well understood by us. Amazon has agreed to pay a fixed monthly fee per aircraft as well as a set rate per block hour flown. Flying is expected to begin in the second quarter of 2020 and be fully ramped up by the fourth quarter of 2020, at which point we will operate 10 cargo aircraft under the ATSA. We also expect that the Amazon operations will complement our core scheduled passenger business.

### Our Route Network

During 2019, we served 56 airports throughout the United States, Mexico, Central America and the Caribbean. The map below represents our current network, including routes currently flown and offered for sale.



### Risk Factors

Participating in this offering involves substantial risk. Our ability to execute our strategy also is subject to certain risks. The risks described under the heading “*Risk Factors*” immediately following this summary may cause us not to realize the full benefits of our competitive strengths or may cause us to be unable to successfully execute all or part of our strategy. Some of the more significant challenges and risks we face include the following:

- changes in economic conditions;

- the price and availability of aircraft fuel and our ability to control other costs;
- threatened or actual terrorist attacks or security concerns;
- the ability to operate in an exceedingly competitive industry;
- factors beyond our control, including air traffic congestion, adverse weather, federal government shutdowns, aircraft-type groundings, increased security measures or disease outbreaks;
- the ability to realize the anticipated strategic and financial benefits of the ATSA with Amazon;
- any restrictions on or increased taxes applicable to charges for ancillary products and services; or
- our concentration in the Minneapolis-St. Paul market.

#### **Our Sponsor**

Founded in 1990, Apollo is a leading global alternative investment manager with offices in New York, Los Angeles, San Diego, Houston, Bethesda, London, Frankfurt, Madrid, Luxembourg, Mumbai, Delhi, Singapore, Hong Kong, Shanghai and Tokyo. Apollo had assets under management of approximately \$331 billion as of December 31, 2019 in credit, private equity and real assets funds invested across a core group of nine industries where Apollo has considerable knowledge and resources.

#### **Implications of Being an Emerging Growth Company**

We are an “emerging growth company” as defined in the Jumpstart Our Business Startups Act, or “JOBS Act,” enacted in April 2012. As an “emerging growth company,” we may take advantage of specified reduced reporting and other requirements that are otherwise applicable to public companies. These provisions include, among other things:

- exemption from the auditor attestation requirement in the assessment on the effectiveness of our internal control over financial reporting;
- exemption from new or revised financial accounting standards applicable to public companies until such standards are also applicable to private companies;
- exemption from compliance with any new requirements adopted by the Public Company Accounting Oversight Board (United States), requiring mandatory audit firm rotation or a supplement to our auditor’s report in which the auditor would be required to provide additional information about the audit and our financial statements;
- an exemption from the requirement to seek non-binding advisory votes on executive compensation and golden parachute arrangements; and
- reduced disclosure about executive compensation arrangements.

We may take advantage of these provisions until the end of the fiscal year following the fifth anniversary of our initial public offering or such earlier time that we are no longer an “emerging growth company.” We will cease to be an “emerging growth company” if we have \$1.07 billion or more in total annual gross revenues during our most recently completed fiscal year, if we become a “large accelerated filer” with a market capitalization of \$700 million or more, or as of any date on which we have issued more than \$1.0 billion in non-convertible debt over the three-year period to such date.

We may choose to take advantage of some, but not all, of these reduced burdens. For example, we have taken advantage of the reduced reporting requirement with respect to disclosure regarding our executive compensation arrangements and expect to take advantage of the exemption from the auditor attestation

requirement in the assessment on the effectiveness of our internal control over financial reporting. In addition, while we have elected to avail ourselves of the exemption to adopt new or revised accounting standards until those standards apply to private companies, we are permitted and have elected to early adopt certain new or revised accounting standards for which the respective standard allows for early adoption. See Note 3 to our audited consolidated financial statements included elsewhere in this prospectus for additional information. For as long as we take advantage of the reduced reporting obligations, the information that we provide stockholders may be different from information provided by other public companies.

In addition, upon the closing of this offering, we will be a “controlled company” within the meaning of the NYSE corporate governance standards because more than 50% of the voting power of our outstanding common stock will be owned by the Apollo Stockholder. For further information on the implications of this distinction, see “*Risk Factors—Risks Related to this Offering and Ownership of Our Common Stock*” and “*Management—Controlled Company*.”

### **The Reorganization Transactions**

We were formed in December 2017 as a Delaware limited liability company under the name SCA Acquisition Holdings, LLC in connection with the acquisition by the Apollo Funds. Following the acquisition by the Apollo Funds in April 2018, one of the Apollo Funds beneficially owned 282,009 outstanding equity interests of SCA Acquisition Holdings, LLC, which historically were denominated as shares of common stock that we refer to as “SCA common stock,” which represented approximately 78.3% of the outstanding SCA common stock, and another Apollo Fund owned a warrant to purchase an additional 2,117,991 shares of SCA common stock at an exercise price of \$0.01 per share.

Prior to this offering, the Apollo Funds engaged in a series of transactions to form a new holding company, which is the Apollo Stockholder, that acquired all of the outstanding shares of SCA common stock held by the Apollo Funds and acquired and immediately exercised all of the warrants to purchase SCA common stock that were held by the Apollo Funds. As a result, the Apollo Stockholder owned 2,400,000 shares of SCA common stock, which represented approximately 96.9% of the outstanding SCA common stock. On January 31, 2020, SCA Acquisition Holdings, LLC was converted into a Delaware corporation pursuant to a statutory conversion and changed its name to Sun Country Airlines Holdings, Inc. In connection with our conversion to a corporation, all of the outstanding shares of SCA common stock were converted into shares of our common stock, the outstanding warrants held by Amazon to purchase shares of SCA common stock were converted into warrants to purchase shares of our common stock and all of the outstanding options to purchase shares of SCA common stock were converted into options to purchase shares of our common stock. As a result of the conversion, Sun Country Airlines Holdings, Inc. continued to hold all property and assets of SCA Acquisition Holdings, LLC and assumed all of the debts and obligations of SCA Acquisition Holdings, LLC, the members of the board of directors of SCA Acquisition Holdings, LLC became the members of the board of directors of Sun Country Airlines Holdings, Inc. and the officers of SCA Acquisition Holdings, LLC became the officers of Sun Country Airlines Holdings, Inc. Prior to the completion of this offering, we will effect a

for 1 stock split of our common stock, with exercise prices for our outstanding warrants and options appropriately adjusted. Following the stock split but before the completion of this offering, we will have an aggregate of \_\_\_\_\_ shares of our common stock outstanding, warrants to purchase an aggregate of \_\_\_\_\_ shares of our common stock outstanding at an exercise price of \$ \_\_\_\_\_ per share, approximately \_\_\_\_\_ % of which have vested, and options to purchase an aggregate of \_\_\_\_\_ shares of our common stock outstanding at a weighted average exercise price of \$ \_\_\_\_\_ per share. In this prospectus, we refer to the transactions described in this paragraph as the “Reorganization Transactions.” The Reorganization Transactions are intended to simplify our capital structure and to facilitate this offering.

**Corporate Information**

We were organized under the laws of the State of Delaware as a limited liability company on December 8, 2017 and converted to a corporation under the laws of the state of Delaware on January 31, 2020. Our principal executive offices are located at 2005 Cargo Road, Minneapolis, MN 55450. Our telephone number is (651) 681-3900. Our website is located at <https://www.suncountry.com>. Our website and the information contained on, or that can be accessed through, our website will not be deemed to be incorporated by reference in, and are not considered part of, this prospectus. You should not rely on our website or any such information in making your decision whether to purchase shares of our common stock.



### The Offering

By participating in this offering, you are representing that you are a citizen of the United States, as defined in 49 U.S.C. § 40102(a)(15). See “*Description of Capital Stock—Limited Ownership and Voting by Foreign Owners.*”

Issuer	Sun Country Airlines Holdings, Inc.
Common stock offered by us	shares.
Common stock offered by the selling stockholder	shares (or shares if the underwriters exercise their option to purchase additional shares in full as described below).
Option to purchase additional shares	The selling stockholder has granted the underwriters an option to purchase up to an additional shares. The underwriters may exercise this option at any time within 30 days from the date of this prospectus. See “ <i>Underwriting.</i> ”
Common stock outstanding after giving effect to this offering	shares.
2019 Warrants to purchase common stock outstanding after giving effect to this offering	Amazon will own warrants to purchase an aggregate of shares of common stock at an exercise price of \$ per share, approximately % of which have vested. See “ <i>Description of Capital Stock—Warrants.</i> ”
Use of proceeds	<p>We estimate that the net proceeds to us from this offering will be approximately \$ million, after deducting underwriting discounts and commissions, based on an assumed initial offering price of \$ per share (the midpoint of the range set forth on the cover page of this prospectus).</p> <p>We currently expect to use approximately \$ million of such proceeds from this offering to pay fees and expenses in connection with this offering, which include legal and accounting fees, SEC and FINRA registration fees, printing expenses, and other similar fees and expenses. We intend to use any remaining proceeds for general corporate purposes. See “<i>Use of Proceeds</i>” for additional information.</p> <p>We will not receive any of the net proceeds from the sale of shares of common stock offered by the selling stockholder.</p>
Controlled company	Upon completion of this offering, the Apollo Stockholder will continue to beneficially own more than 50% of the voting power of our outstanding common stock. As a result, we intend to avail ourselves of the “controlled company” exemptions under the rules of the NYSE, including exemptions from certain of the corporate governance listing requirements. See “ <i>Management—Controlled Company.</i> ”

Dividend policy	We do not intend to pay cash dividends on our common stock in the foreseeable future. However, we may, in the future, decide to pay dividends on our common stock. Any declaration and payment of cash dividends in the future, if any, will be at the discretion of our board of directors and will depend upon such factors as earnings levels, cash flows, capital requirements, levels of indebtedness, restrictions imposed by applicable law, our overall financial condition, restrictions in our debt agreements, and any other factors deemed relevant by our board of directors. See “ <i>Dividend Policy</i> .”
Listing	We intend to apply to list our common stock on the NYSE under the symbol “SNCY.”
Risk Factors	You should read the section titled “ <i>Risk Factors</i> ” beginning on page 22 of, and the other information included in, this prospectus for a discussion of some of the risks and uncertainties you should carefully consider before deciding to invest in our common stock.

Except as otherwise indicated, all of the information in this prospectus:

- gives effect to the Reorganization Transactions;
- assumes an initial public offering price of \$        per share of common stock, the midpoint of the range set forth on the cover page of this prospectus;
- assumes no exercise of the underwriters’ option to purchase up to        additional shares of common stock from the selling stockholder;
- assumes no exercise of the 2019 Warrants to purchase an aggregate of        shares of common stock, approximately    % of which have vested. As is the case for investment in our company generally, the exercise of the 2019 Warrants is limited by restrictions imposed by federal law on foreign ownership and control of U.S. airlines. See “*Description of Capital Stock—Limited Ownership and Voting by Foreign Owners*”;
- does not reflect an additional        shares of common stock reserved for future grant under our new equity incentive plan (the “Omnibus Equity Plan”). See “*Executive Compensation—Equity Compensation Plans—2020 Omnibus Incentive Plan*”; and
- does not reflect    shares of common stock that may be issued upon the exercise of stock options outstanding as of the consummation of this offering under the SCA Acquisition Holdings, LLC Equity Incentive Plan (the “SCA Acquisition Equity Plan”). The following table sets forth the outstanding stock options under the SCA Acquisition Equity Plan as of December 31, 2019 (giving effect to the Reorganization Transactions):

	Number of Options(1)	Weighted-Average Exercise Price Per Share
Vested stock options (time-based vesting)		\$
Unvested stock options (time-based vesting)		\$
Unvested stock options (performance-based vesting)		\$

(1) Upon a holder’s exercise of one option, we will issue to the holder one share of common stock.

### Summary Consolidated Financial and Operating Information

The following tables present our summary consolidated financial and operating information for the periods indicated. We have derived our summary historical consolidated statement of operations data for the year ended December 31, 2019 and for the periods January 1, 2018 through April 10, 2018 (Predecessor) and April 11, 2018 through December 31, 2018 (Successor) from our audited consolidated financial statements included elsewhere in this prospectus. We have derived our summary historical consolidated balance sheet data as of December 31, 2019 from our audited consolidated financial statements included elsewhere in this prospectus.

The significant differences in accounting for the Successor period as compared to the Predecessor period, which were established as part of our acquisition by the Apollo Funds, are in (1) aircraft rent, due to the over-market liabilities related to unfavorable terms of our existing aircraft leases and maintenance reserve payments, which will be amortized on a straight-line basis as a reduction of aircraft rent over the remaining life of each lease, (2) maintenance expenses, due to recognizing a liability (or contra-asset) that will offset expenses for maintenance events incurred by the Successor but paid for by the Predecessor and (3) depreciation and amortization, due to the recognition of our property and equipment and other intangible assets at fair value at the time of the acquisition, which will be amortized through depreciation and amortization on a straight-line basis over their respective useful lives. The following summary consolidated financial and operating information should be read in conjunction with the section titled “*Management’s Discussion and Analysis of Financial Condition and Results of Operations*” and our audited consolidated financial statements and the related notes included elsewhere in this prospectus.

	<u>Successor</u>	<u>Successor</u>	<u>Predecessor</u>
	For the year ended December 31, 2019	For the period April 11, 2018 through December 31, 2018	For the period January 1, 2018 through April 10, 2018
(in thousands, except per share data)			
<b>Statement of Operations Data:</b>			
<b>Operating Revenues:</b>			
Passenger	\$	\$ 335,824	\$ 172,897
Other		49,107	24,555
Total Operating Revenue		<u>384,931</u>	<u>197,452</u>
<b>Operating Expenses:</b>			
Aircraft Fuel	\$	\$ 119,553	\$ 45,790
Salaries, Wages, and Benefits		90,263	36,964
Aircraft Rent <sup>(1)</sup>		36,831	28,329
Maintenance <sup>(2)</sup>		15,491	9,508
Sales and Marketing		17,180	10,854
Depreciation and Amortization <sup>(3)</sup>		14,405	2,526
Ground Handling		23,828	8,619
Landing Fees and Airport Rent		25,977	10,481
Special Items, net		(6,706)	271
Other Operating, net		40,877	17,994
Total Operating Expenses		<u>377,699</u>	<u>171,336</u>
Operating Income		<u>7,232</u>	<u>26,116</u>

[Table of Contents](#)

	<u>Successor</u> For the year ended December 31, 2019	<u>Successor</u> For the period April 11, 2018 through December 31, 2018	<u>Predecessor</u> For the period January 1, 2018 through April 10, 2018
(in thousands, except per share data)			
<b>Non-operating Income (Expense):</b>			
Interest Income	\$	\$ 258	\$ 96
Interest Expense		(6,060)	(339)
Other, net		(1,636)	37
Total Non-operating Expense		(7,438)	(206)
Income (Loss) before Income Tax		(206)	25,910
Income Tax Expense		161	—
Net Income (Loss)	\$	\$ (367)	\$ 25,910
<b>Net Income (Loss) per share to common stockholders:</b>			
Basic and diluted	\$	\$ (0.15)	\$ 0.26
<b>Weighted average shares outstanding:</b>			
Basic and diluted		2,472	100,000

- (1) Aircraft Rent expense for the Successor period is reduced due to amortization of a liability representing lease rates and maintenance reserves which were higher than market terms of similar leases at the time of our acquisition by the Apollo Funds. This liability was recognized at the time of the acquisition and is being amortized into earnings through a reduction of Aircraft Rent on a straight-line basis over the remaining life of each lease. See Note 2 and Note 3 to our audited consolidated financial statements included elsewhere in this prospectus for additional information.
- (2) Maintenance expense for the Successor period is reduced due to recognizing a liability (or contra-asset) to represent the Successor's obligation to perform planned maintenance events paid for by the Predecessor on leased aircraft at the date of our acquisition by the Apollo Funds. The liability (or contra-asset) is recognized as a reduction to Maintenance expense as reimbursable maintenance events are performed and maintenance expense is incurred. See Note 2 and Note 3 to our audited consolidated financial statements included elsewhere in this prospectus for additional information.
- (3) Depreciation and amortization expense increased in the Successor period due to higher fair values for certain acquired assets and to the amortization of definite-lived intangible assets. See Note 2 to our audited consolidated financial statements included elsewhere in this prospectus for additional information.

	<u>As of December 31, 2019</u>		
	<u>Actual</u>	<u>Pro forma(1)</u>	<u>Pro forma as adjusted(2)</u>
(in thousands)			
<b>Consolidated Balance Sheet Data:</b>			
Cash and cash equivalents	\$	\$	\$
Total assets			
Long-term debt and finance leases, including current portion			
Total stockholders' equity			

- (1) The pro forma consolidated balance sheet data gives effect to the Reorganization Transactions. Following this offering, 2019 Warrants to purchase an aggregate of \_\_\_\_\_ shares of common stock, approximately \_\_\_\_\_ % of which have vested, will remain outstanding. As is the case for investment in our company generally, the exercise of the 2019 Warrants is limited by restrictions imposed by federal law on foreign ownership and control of U.S. airlines. See "Description of Capital Stock—Limited Ownership and Voting by Foreign Owners."

- (2) The pro forma as adjusted balance sheet data gives further effect to this offering and the application of the net proceeds to us of this offering as of December 31, 2019 as described under “Use of Proceeds.”

(in thousands)	<u>Successor</u> For the year ended December 31, 2019	<u>Successor</u> For the period April 11, 2018 through December 31, 2018	<u>Predecessor</u> For the period January 1, 2018 through April 10, 2018
<b>Non-GAAP Financial Data:</b>			
Adjusted Net Income(1)	\$	\$ (5,871)	\$ 26,181
Adjusted EBITDAR(1)		49,688	57,279

- (1) Adjusted Net Income and Adjusted EBITDAR are non-GAAP measures and are included as supplemental disclosures because we believe they are useful indicators of our operating performance. Derivations of net income and EBITDAR are well recognized performance measurements in the airline industry that are frequently used by our management, as well as by investors, securities analysts and other interested parties in comparing the operating performance of companies in our industry. Further, we believe Adjusted EBITDAR is useful in evaluating our operating performance compared to our competitors because its calculation isolates the effects of financing in general, the accounting effects of capital spending and acquisitions (primarily aircraft, which may be acquired directly, directly subject to acquisition debt, by finance lease or by operating lease, each of which is presented differently for accounting purposes), and income taxes, which may vary significantly between periods and for different companies for reasons unrelated to overall operating performance.

Adjusted Net Income and Adjusted EBITDAR have limitations as analytical tools. Some of the limitations applicable to these measures include: Adjusted Net Income and Adjusted EBITDAR do not reflect the impact of certain cash charges resulting from matters we consider not to be indicative of our ongoing operations; Adjusted EBITDAR does not reflect our cash expenditures, or future requirements, for capital expenditures or contractual commitments; Adjusted EBITDAR does not reflect changes in, or cash requirements for, our working capital needs; Adjusted Net Income and Adjusted EBITDAR do not reflect the interest expense, or the cash requirements necessary to service interest or principal payments, on our debt; although depreciation and amortization are non-cash charges, the assets being depreciated and amortized will often have to be replaced in the future, and Adjusted EBITDAR does not reflect any cash requirements for such replacements; and other companies in our industry may calculate Adjusted Net Income and Adjusted EBITDAR differently than we do, limiting each measure’s usefulness as a comparative measure. Because of these limitations Adjusted Net Income and Adjusted EBITDAR should not be considered in isolation or as a substitute for performance measures calculated in accordance with GAAP.

As derivations of Adjusted Net Income and Adjusted EBITDAR are not determined in accordance with GAAP, such measures are susceptible to varying calculations and not all companies calculate the measures in the same manner. As a result, derivations of net income, including Adjusted Net Income and Adjusted EBITDAR, as presented may not be directly comparable to similarly titled measures presented by other companies. In addition, Adjusted EBITDAR should not be viewed as a measure of overall performance since it excludes aircraft rent, which is a normal, recurring cash operating expense that is necessary to operate our business. For the foregoing reasons, each of Adjusted Net Income and Adjusted EBITDAR has significant limitations which affect its use as an indicator of our profitability. Accordingly, you are cautioned not to place undue reliance on this information.

The following table presents the reconciliation of Net Income to Adjusted Net Income for the periods presented below.

(in thousands)	<u>Successor</u> For the year ended December 31, 2019	<u>Successor</u> For the period April 11, 2018 through December 31, 2018	<u>Predecessor</u> For the period January 1, 2018 through April 10, 2018
<b>Adjusted Net Income reconciliation:</b>			
Net income	\$	\$ (367)	\$ 25,910
Special items, net(a)		(6,706)	271
Gain on asset transactions, net		(811)	—
Stock compensation expense		373	—
Income tax effect of adjusting items, net(b)		1,640	—
<b>Adjusted Net Income</b>	<b>\$</b>	<b>\$ (5,871)</b>	<b>\$ 26,181</b>

## [Table of Contents](#)

- (a) See Note 14 to our audited consolidated financial statements included elsewhere in this prospectus for additional information on the components of special items, net.  
(b) The tax effect of adjusting items, net is calculated at the Company's statutory rate for the applicable period.

The following table presents the reconciliation of Net Income to Adjusted EBITDAR for the periods presented below.

	<u>Successor</u>	<u>Successor</u>	<u>Predecessor</u>
	<u>For the year ended December 31, 2019</u>	<u>For the period April 11, 2018 through December 31, 2018</u>	<u>For the period January 1, 2018 through April 10, 2018</u>
(in thousands)			
<b>Adjusted EBITDAR reconciliation:</b>			
Net income	\$	\$ (367)	\$ 25,910
Special items, net		(6,706)	271
Interest expense		6,060	339
Gain on asset transactions, net		(811)	—
Stock compensation expense		373	—
Interest income		(258)	(96)
Provision for income taxes		161	—
Depreciation and amortization		14,405	2,526
Aircraft rent		36,831	28,329
<b>Adjusted EBITDAR</b>	<u>\$</u>	<u>\$ 49,688</u>	<u>\$ 57,279</u>



### Key Operating Statistics and Metrics

	2019			2018			2017		
	Scheduled Service	Charter Service	Total System	Scheduled Service	Charter Service	Total System	Scheduled Service	Charter Service	Total System
Departures	24,392	9,175	33,567	19,940	8,254	28,194	20,488	7,981	28,469
Block hours	80,719	20,418	101,137	68,548	17,335	85,883	68,357	16,941	85,298
Aircraft miles	32,217,934	7,520,549	39,738,483	27,725,797	6,369,866	34,095,663	27,823,467	6,358,418	34,181,885
ASMs (in thousands)	5,747,391	1,317,172	7,064,563	4,455,838	1,007,391	5,463,229	4,270,718	979,756	5,250,474
TRASM (in cents)(1)	*	*	*	*	*	10.66	*	*	10.65
Average aircraft available for service(1)	*	*	28.4	*	*	24.3	*	*	23.4
Aircraft at end of period(1)	*	*	31	*	*	30	*	*	26
Average daily aircraft utilization (in hours) (1)	*	*	9.6	*	*	9.7	*	*	9.9
Passengers(2)	3,565,939	*	*	2,614,929	*	*	2,502,082	*	*
RPMs (in thousands) (2)	4,473,347	*	*	3,653,007	*	*	3,419,527	*	*
PRASM (in cents) (2)	*	*	*	8.01	*	*	8.71	*	*
Load factor(2)	82.5%	*	*	82.4%	*	*	80.1%	*	*
Average fare(2)	\$	*	\$	136.42	*	\$	148.60	*	\$
Ancillary revenue per passenger(2)	\$	*	\$	21.70	*	\$	13.34	*	\$
Charter revenue per block hour	*	\$	*	\$	8,767	*	\$	7,818	*
Fuel gallons consumed (in thousands)	63,240	14,802	78,042	52,303	12,678	64,981	52,104	12,551	64,656
Fuel cost per gallon, excl. derivatives	*	\$	2.26	*	\$	2.34	*	\$	1.85
CASM (in cents)(3)	*	*	*	*	*	10.05	*	*	10.09
CASM ex (in cents) (3)	*	*	*	*	*	6.94	*	*	7.79
Adjusted CASM (in cents) (3)(4)	*	*	*	*	*	7.05	*	*	7.79
Employees at end of period	*	*	1,558	*	*	1,549	*	*	1,889

See "Glossary of Terms" for definitions of terms used in this table.

\* Certain operating statistics and metrics are not presented as they are not calculable or are not utilized by management.

(1) Scheduled service and charter service utilize the same fleet of aircraft. Aircraft counts and utilization metrics are shown on a system basis only.

(2) Passenger-related statistics and metrics are shown only for scheduled service. Charter service revenue is driven by flight statistics.

(3) CASM is a key airline cost metric. CASM is defined as operating expenses divided by total available seat miles. CASM ex is one of the most important measures used by management and by our board of directors in assessing quarterly and annual cost performance. CASM ex is also a measure commonly used by industry analysts and we believe it is an important metric by which they compare our airline to others in the industry, although other airlines may exclude certain other costs in their calculation of CASM ex (or CASM excluding fuel). The measure is also the subject of frequent questions from investors. By excluding volatile fuel expenses that are outside of our control from our unit metrics, we believe that we have better visibility into the results of operations and our non-fuel cost initiatives. We also exclude certain commissions and other costs of selling our vacations product from this measure as these costs are unrelated to our airline operations and improve comparability to our peers. Our industry is highly competitive and is characterized by high fixed costs, so even a small reduction in non-fuel operating costs can lead to a significant improvement in operating results. In addition, we believe that all domestic carriers are similarly impacted by changes in jet fuel costs over the long run, so it is important for management and investors to understand the impact and trends in company-specific cost drivers, such as labor rates, aircraft costs and maintenance costs, and productivity, which are more controllable by management.

(4) We exclude from Adjusted CASM fuel, certain commissions and other costs of selling our vacations product and special items, as defined in the relevant reporting period, that are not representative of the ongoing costs necessary to our airline operations and may improve comparability between periods. We also exclude stock compensation expense when computing Adjusted CASM. The Company's compensation strategy includes the use of stock-based compensation to attract and retain employees and executives and is principally aimed at aligning their interests with those of our stockholders and at long-term employee retention, rather than to motivate or reward operational performance for any particular period. Thus, stock-based compensation expense varies for reasons that are generally unrelated to operational decisions and performance in any particular period. Adjusted CASM is one of the most important measures used by management and by our board of directors in assessing quarterly and annual cost performance. As derivations of Adjusted CASM are not determined in accordance with GAAP, such measures are susceptible to varying calculations and not all companies calculate the measures in the same manner. As a result, derivations of Adjusted CASM as presented may not be directly comparable to similarly titled measures presented by other companies.

[Table of Contents](#)

The following table presents the reconciliation of CASM to Adjusted CASM.

	for the year ended December 31,		
	2019	2018	2017
	Per ASM	Per ASM	Per ASM
	(in cents)	(in cents)	(in cents)
<b>CASM</b>		10.05	10.09
Aircraft fuel		3.03	2.25
Sun Country Vacations		0.08	0.04
<b>CASM ex</b>		<b>6.94</b>	<b>7.79</b>
Special items, net		(0.12)	—
Stock compensation expense		—	—
<b>Adjusted CASM</b>		<b>7.05</b>	<b>7.79</b>

## Glossary of Terms

Set forth below is a glossary of certain terms used in this prospectus:

“Adjusted CASM” means CASM excluding fuel and certain commissions and other costs of selling our vacations product and excluding special items and other adjustments as defined for the relevant reporting period that are not representative of the ongoing costs necessary to our airline operations and may improve comparability between periods. We also exclude stock compensation expense when computing Adjusted CASM. Our compensation strategy includes the use of stock-based compensation to attract and retain employees and executives and is principally aimed at aligning their interests with those of our stockholders and at long-term employee retention, rather than to motivate or reward operational performance for any particular period. Thus, stock-based compensation expense varies for reasons that are generally unrelated to operational decisions and performance in any particular period. When Adjusted CASM is referenced or presented for other airlines, it has been adjusted to our stage length of 1,192 miles.

“Aircraft miles” means miles flown by all of our aircraft, measured by summing up the miles for each completed flight segment.

“Air traffic liability” means the value of tickets sold in advance of travel.

“ALPA” means the Air Line Pilots Association, the union representing our pilots.

“Ancillary revenue” consists primarily of revenue generated from air travel-related services such as baggage fees, seat selection and upgrade fees, itinerary service fees, on-board sales and sales of trip insurance.

“Ancillary services” refers to the services that generate ancillary revenue.

“Available seat miles” or “ASMs” means the number of seats available for passengers multiplied by the number of miles the seats are flown.

“Average aircraft” means the average number of aircraft used in flight operations, as calculated on a daily basis.

“Average daily aircraft utilization” means block hours divided by number of days in the period divided by average aircraft.

“Average stage length” means the average number of statute miles flown per flight segment.

“Block hours” means the number of hours during which the aircraft is in revenue service, measured from the time of gate departure before take-off until the time of gate arrival at the destination.

“CASM” or “unit costs” means operating expenses divided by total ASMs. When CASM is referenced or presented for other airlines, it has been adjusted to our stage length of 1,192 miles.

“CASM ex” means CASM excluding fuel and certain commissions and other costs of selling our vacations product. When CASM ex is referenced or presented for other airlines, it has been adjusted to our stage length of 1,192 miles.

“CBA” means a collective bargaining agreement.

“CBP” means the United States Customs and Border Protection.

## [Table of Contents](#)

“Charter service” means flights operated for specific customers who purchase the entire flight from us and specify the origination and destination.

“Citizen of the United States” means (A) an individual who is a citizen of the United States; (B) a partnership each of whose partners is an individual who is a citizen of the United States; or (C) a corporation or association organized under the laws of the United States or a State, the District of Columbia, or a territory or possession of the United States, of which the president and at least two-thirds of the board of directors and other managing officers are citizens of the United States, which is under the actual control of citizens of the United States, and in which at least 75% of the voting interest is owned or controlled by persons that are citizens of the United States.

“Completion factor” means the percentage of scheduled flights that are completed.

“DOT” means the United States Department of Transportation.

“EPA” means the United States Environmental Protection Agency.

“ETOPS” means Extended-Range Twin-Engine Operational Performance Standards.

“FAA” means the United States Federal Aviation Administration.

“GDS” means a Global Distribution System such as Amadeus, Sabre and Travelport, used by travel agencies and corporations to purchase tickets on participating airlines.

“IBT” means the International Brotherhood of Teamsters, the union representing our flight attendants.

“LCC” means low-cost carrier and includes JetBlue Airways and Southwest Airlines.

“Load factor” means the percentage of aircraft seat miles actually occupied on a flight (RPMs divided by ASMs) for scheduled service.

“Mainline U.S. passenger airlines” includes us, Alaska Airlines, Allegiant Travel Company, American Airlines, Delta Air Lines, Frontier Airlines, Hawaiian Airlines, JetBlue Airways, Southwest Airlines, Spirit Airlines and United Airlines.

“NMB” means the National Mediation Board.

“OTAs” means online travel agents.

“Passengers” means the total number of passengers flown on all flight segments.

“PRASM” means scheduled service revenue divided by ASMs for scheduled service.

“Revenue passenger miles” or “RPMs” means the number of miles flown by passengers.

“RLA” means the United States Railway Labor Act.

“Scheduled service” means transportation of passengers on flights we operate in and out of airports on a schedule of routes and flight times we provide for general sale.

“Scheduled service revenue” consists of base fares, unused and expired passenger credits and other expired travel credits for scheduled service.

## [Table of Contents](#)

“Stage-length adjustment” refers to an adjustment that can be utilized to compare CASM, PRASM and TRASM across airlines with varying stage lengths. All other things being equal, the same airline will have lower CASM, PRASM and TRASM as stage length increases since fixed and departure related costs are spread over increasingly longer average flight lengths. Therefore, as one method to facilitate comparison of these quantities across airlines (or even across the same airline for two different periods if the airline’s average stage length has changed significantly), it is common in the airline industry to settle on a common assumed stage length and then to adjust CASM, PRASM and TRASM appropriately. Stage-length adjusted comparisons are achieved by multiplying base CASM or RASM by a quotient, the numerator of which is the square root of the carrier’s stage length and the denominator of which is the square root of the common stage length. Stage-length adjustment techniques require judgment and different observers may use different techniques. For stage-length PRASM or TRASM comparisons in this prospectus, the stage length being utilized is the aircraft stage length.

“TRASM” or “unit revenue” means total revenue divided by total ASMs. When TRASM is referenced or presented for other airlines, it has been adjusted to our stage length of 1,192 miles.

“TSA” means the United States Transportation Security Administration.

“TWU” means the Transport Workers Union, the union representing our dispatchers.

“ULCC” means ultra low-cost carrier and includes Allegiant Travel Company, Frontier Airlines and Spirit Airlines.

“VFR” means visiting friends and relatives.

## RISK FACTORS

*You should carefully consider the risks and uncertainties described below, as well as the other information contained in this prospectus, including our consolidated financial statements and the related notes thereto included elsewhere in this prospectus and “Management’s Discussion and Analysis of Financial Condition and Results of Operations,” before deciding to invest in our common stock. In addition, past financial performance may not be a reliable indicator of future performance and historical trends should not be used to anticipate results or trends in future periods. Any of the following risks could materially adversely affect our business, financial condition and results of operations, in which case the trading price of our common stock could decline and you could lose all or part of your investment.*

### Risks Related to Our Industry

***The demand for airline services is highly sensitive to changes in economic conditions, and another recession or similar economic downturn in the United States would weaken demand for our services and have a material adverse effect on our business, results of operations and financial condition.***

The demand for travel services is affected by U.S. and global economic conditions. Unfavorable economic conditions have historically reduced airline travel spending. For most passengers visiting friends and relatives and cost-conscious leisure travelers (our primary market), travel is a discretionary expense, and during periods of unfavorable economic conditions as a result of such carriers’ low base fares travelers have often elected to replace air travel at such times with car travel or other forms of ground transportation or have opted not to travel at all. Likewise, during periods of unfavorable economic conditions, businesses have deferred air travel or forgone it altogether. In addition, most of our charter revenue is generated from ad hoc or short-term contracts with repeat customers, and these customers may cease using our services or seek to negotiate more aggressive pricing during periods of unfavorable economic conditions. Any reduction in charter revenue during such periods could also increase our unit costs and thus have a material adverse effect on our business, results of operations and financial condition. Travelers have also reduced spending by purchasing fewer ancillary services, which can result in a decrease in average revenue per seat. Because airlines typically have relatively high fixed costs as a percentage of total costs, much of which cannot be mitigated during periods of lower demand for air travel, the airline business is particularly sensitive to changes in economic conditions. A reduction in the demand for air travel due to unfavorable economic conditions also limits our ability to raise fares to counteract increased fuel, labor and other costs. If U.S. or global economic conditions are unfavorable or uncertain for an extended period of time, it would have a material adverse effect on our business, results of operations and financial condition.

***Our business has been and in the future may be materially adversely affected by the price and availability of aircraft fuel. Unexpected increases in the price of aircraft fuel or a shortage or disruption in the supply of aircraft fuel could have a material adverse effect on our business, results of operations and financial condition.***

The cost of aircraft fuel is highly volatile and in recent years has been our largest individual operating expense, accounting for approximately 28.1% and 30.1% of our operating expenses for the years ended December 31, 2019 and 2018, respectively. High fuel prices or increases in fuel costs (or in the price of crude oil) could have a material adverse effect on our business, results of operations and financial condition, including as a result of legacy network airlines and LCCs adapting more rapidly or effectively to higher fuel prices through new-technology aircraft that is more fuel efficient than our aircraft. Over the past several years, the price of aircraft fuel has fluctuated substantially and prices continue to be highly volatile and could increase significantly at any time. In addition, prolonged low fuel prices could limit our ability to differentiate our product and low fares from those of the legacy network airlines and LCCs, as prolonged low fuel prices could enable such carriers to, among other things, substantially decrease their costs, fly longer stages or utilize older aircraft.

Our business is also dependent on the availability of aircraft fuel (or crude oil), which is not predictable. Weather-related events, natural disasters, terrorism, wars, political disruption or instability involving



## Table of Contents

oil-producing countries, changes in governmental or cartel policy concerning crude oil or aircraft fuel production, labor strikes or other events affecting refinery production, transportation, taxes or marketing, environmental concerns, market manipulation, price speculation, changes in currency exchange rates and other unpredictable events may drive actual or perceived fuel supply shortages. Shortages in the availability of, or increases in demand for, crude oil in general, other crude oil-based fuel derivatives and aircraft fuel in particular could result in increased fuel prices and could have a material adverse effect on our business, results of operations and financial condition.

We may not be able to increase ticket prices sufficiently to cover increased fuel costs, particularly when fuel prices rise quickly. We sell a significant number of tickets to passengers well in advance of travel, and, as a result, fares sold for future travel may not reflect increased fuel costs. In addition, our ability to increase ticket prices to offset an increase in fuel costs is limited by the competitive nature of the airline industry and the price sensitivity associated with air travel, particularly leisure travel, and any increases in fares may reduce the general demand for air travel.

From time to time, we may enter into fuel derivative contracts in order to mitigate the risk to our business from future volatility in fuel prices but such contracts may not fully protect us from all related risks. As of December 31, 2019, we had hedges in place for approximately 61% of our projected fuel requirements for scheduled service operations in 2020, with all of our then existing options expected to be exercised or expire by the end of 2021. Generally speaking, our charter operations have pass-through provisions for fuel costs, and as such we do not hedge our fuel requirements for that portion of our business. Our hedges in place at the end of 2019 consisted of collars and the underlying commodities consisted of both Gulf Coast Jet Fuel contracts as well as West Texas Intermediate Crude Oil contracts.

Our hedging strategy to date has been designed to protect our liquidity position in the event of a rapid and/or sustained rise in fuel prices that does not allow for immediate response in ticket prices. We may enter into derivatives that do not qualify for hedge accounting, which can impact our results of operations and increase the volatility of our earnings due to recognizing the mark-to-market impact of our hedge portfolio as a result of changes in the forward markets for oil and/or jet fuel. We cannot assure you our fuel hedging program will be effective or that we will maintain a fuel hedging program. Even if we are able to hedge portions of our future fuel requirements, we cannot guarantee that our hedge contracts will provide an adequate level of protection against increased fuel costs or that the counterparties to our hedge contracts will be able to perform. Additionally, our ability to realize the benefit of declining fuel prices will be limited by the impact of any fuel hedges in place, we may incur additional expenses in connection with entering into derivative contracts and we may record significant losses on fuel hedges during periods of declining prices. A failure of our fuel hedging strategy, potential margin funding requirements, overpaying for fuel through the use of hedging arrangements or our failure to maintain a fuel hedging program could prevent us from adequately mitigating the risk of fuel price increases and could have a material adverse effect on our business, results of operations and financial condition.

***Threatened or actual terrorist attacks or security concerns involving airlines could have a material adverse effect on our business, results of operations and financial condition.***

Past terrorist attacks or attempted attacks, particularly those against airlines, have caused substantial revenue losses and increased security costs, and any actual or threatened terrorist attack or security breach, even if not directly against an airline, could have a material adverse effect on our business, results of operations and financial condition. Security concerns resulting in enhanced passenger screening, increased regulation governing carry-on baggage and other similar restrictions on passenger travel may further increase passenger inconvenience and reduce the demand for air travel. In addition, increased or enhanced security measures have tended to result in higher governmental fees imposed on airlines, resulting in higher operating costs for airlines, which we may not be able to pass on to consumers in the form of higher prices. Terrorist attacks, or the fear of such attacks or other hostilities (including elevated national threat warnings or selective cancellation or redirection of flights due to terror threats), even if not made directly on or involving the airline industry, could have a negative impact on

the airline industry and have a material adverse effect on our business, results of operations and financial condition.

***The airline industry is exceedingly competitive, and we compete against LCCs, ULCCs and legacy network airlines; if we are not able to compete successfully in our markets, our business will be materially adversely affected.***

We face significant competition with respect to routes, fares and services. Within the airline industry, we compete with ULCCs, LCCs and legacy network airlines for airline passengers traveling on the routes we serve, particularly customers traveling in economy or similar classes of service. Competition on most of the routes we presently serve is intense, due to the large number of carriers in those markets. Furthermore, other airlines may begin service or increase existing service on routes where we currently face no or little competition. In almost all instances, our competitors are larger than we are and possess significantly greater financial and other resources than we do.

The airline industry is particularly susceptible to price discounting because, once a flight is scheduled, airlines incur only nominal additional costs to provide service to passengers occupying otherwise unsold seats. Increased fare or other price competition could adversely affect our operations. Airlines typically use discount fares and other promotions to stimulate traffic during normally slower travel periods to generate cash flow and to increase revenue per available seat mile. The prevalence of discount fares can be particularly acute when a competitor has excess capacity to sell. Moreover, many other airlines have unbundled their services, at least in part, by charging separately for services such as baggage and advance seat selection, which previously were offered as a component of base fares. This unbundling and other cost-reducing measures could enable competitor airlines to reduce fares on routes that we serve. The availability of low-priced fares coupled with an increase in domestic capacity has led to dramatic changes in pricing behavior in many U.S. markets. Many domestic carriers began matching lower cost airline pricing, either with limited or unlimited inventory.

Our growth and the success of our high-growth, low-cost business model could stimulate competition in our markets through our competitors' development of their own LCC or ULCC strategies, new pricing policies designed to compete with LCCs, ULCCs or new market entrants. Airlines increase or decrease capacity in markets based on perceived profitability. If our competitors increase overall industry capacity, or capacity dedicated to a particular domestic or foreign region, market or route that we serve, it could have a material adverse impact on our business. If a legacy network airline were to successfully develop a low-cost product or if we were to experience increased competition from LCCs, our business could be materially adversely affected. Regardless of cost structure, the domestic airline industry has often been the source of fare wars undertaken to grow market share or for other reasons. Additionally, each of American Airlines, Delta Air Lines and United Airlines has begun to offer a so-called "basic economy" offering with reduced amenities designed specifically to compete against LCCs and ULCCs, which presents a significant form of competition for us.

A competitor adopting an LCC or ULCC strategy may have greater financial resources and access to lower cost sources of capital than we do, which could enable them to operate their business with a lower cost structure, or enable them to operate with lower marginal revenues without substantial adverse effects, than we can. If these competitors adopt and successfully execute an LCC or ULCC business model, our business could be materially adversely affected.

Similarly, our competitors may choose to commence or expand their existing charter operations, which could adversely impact our ability to obtain or renew charter contracts, especially in periods of low demand. This could result in decreases in our charter services market share and reduced profitability for our charter operations, which would have a material adverse effect on our business, results of operations and financial condition.

There has been significant consolidation within the airline industry, including, for example, the combinations of American Airlines and US Airways, Delta Air Lines and Northwest Airlines, United Airlines and Continental

## Table of Contents

Airlines, Southwest Airlines and AirTran Airways, and Alaska Airlines and Virgin America. In the future, there may be additional consolidation in our industry. Business combinations could significantly alter industry conditions and competition within the airline industry and could permit our competitors to reduce their fares.

The extremely competitive nature of the airline industry could prevent us from attaining the level of passenger traffic or maintaining the level of fares or ancillary revenues required to sustain profitable operations in new and existing markets and could impede our growth strategy, which could harm our operating results. Due to our relatively small size, we are susceptible to a fare war or other competitive activities in one or more of the markets we serve, which could have a material adverse effect on our business, results of operations and financial condition.

***Airlines are often affected by factors beyond their control including: air traffic congestion at airports; air traffic control inefficiencies; government shutdowns; FAA grounding of aircraft; major construction or improvements at airports; adverse weather conditions, such as hurricanes or blizzards; increased security measures; new travel-related taxes; or the outbreak of disease, any of which could have a material adverse effect on our business, results of operations and financial condition.***

Like other airlines, our business is affected by factors beyond our control, including air traffic congestion at airports, air traffic control inefficiencies, major construction or improvements at airports at which we operate, increased security measures, new travel-related taxes and fees, adverse weather conditions, natural disasters and the outbreak of disease. Factors that cause flight delays frustrate passengers and increase costs and decrease revenues, which in turn could adversely affect profitability. The federal government controls all U.S. airspace, and airlines are completely dependent on the FAA to operate that airspace in a safe, efficient and affordable manner. The air traffic control system, which is operated by the FAA, faces challenges in managing the growing demand for U.S. air travel. U.S. and foreign air traffic controllers often rely on outdated technologies that routinely overwhelm the system and compel airlines to fly inefficient, indirect routes resulting in delays. The federal government also controls airport security. In addition, there are proposals before Congress that would treat a wide range of consumer protection issues, which could increase the costs of doing business. There are additional proposals before Congress that could potentially lead to the privatization of the United States' air traffic control system, which could adversely affect our business. Further, implementation of the Next Generation Air Transport System, or NextGen, by the FAA would result in changes to aircraft routings and flight paths that could lead to increased noise complaints and lawsuits, resulting in increased costs. In addition, federal government shutdowns can affect the availability of federal resources necessary to provide air traffic control and airport security. Furthermore, a federal government grounding of our aircraft type could result in flight cancellations and adversely affect our business.

Adverse weather conditions and natural disasters, such as hurricanes, thunderstorms, winter snowstorms or earthquakes, can cause flight cancellations or significant delays, and in the past have led to Congressional demands for investigations. Cancellations or delays due to adverse weather conditions or natural disasters, air traffic control problems or inefficiencies, breaches in security or other factors may affect us to a greater degree than other, larger airlines that may be able to recover more quickly from these events, and therefore could have a material adverse effect on our business, results of operations and financial condition to a greater degree than other air carriers. Because of our day of week, limited schedule and optimized utilization and point-to-point network, operational disruptions can have a disproportionate impact on our ability to recover. In addition, many airlines reaccommodate their disrupted passengers on other airlines at prearranged rates under flight interruption manifest agreements. We have been unsuccessful in procuring any of these agreements with our peers, which makes our recovery from disruption more challenging than for larger airlines that have these agreements in place. Similarly, outbreaks of pandemic or contagious diseases, such as ebola, measles, avian flu, severe acute respiratory syndrome (SARS), novel coronavirus (2019-nCoV), H1N1 (swine) flu, pertussis (whooping cough) and zika virus, could result in significant decreases in passenger traffic and the imposition of government restrictions in service and could have a material adverse impact on the airline industry. Any increases in travel-related taxes could also result in decreases in passenger traffic. Any general reduction in airline passenger traffic could have a material adverse effect on our business, results of operations and financial condition. Moreover, U.S. federal government shutdowns may cause delays and cancellations or reductions in discretionary travel due

## [Table of Contents](#)

to longer security lines, including as a result of furloughed government employees or reductions in staffing levels, including air traffic controllers. U.S. government shutdowns may also impact our ability to take delivery of aircraft and commence operations in new domestic stations. Another extended shutdown like the one in December 2018-January 2019 may have a negative impact on our operations and financial results.

***Risks associated with our presence in international markets, including political or economic instability, and failure to adequately comply with existing and changing legal requirements, may materially adversely affect us.***

Some of our target growth markets include countries with less developed economies, legal systems, financial markets and business and political environments that are vulnerable to economic and political disruptions, such as significant fluctuations in gross domestic product, interest and currency exchange rates, civil disturbances, government instability, nationalization and expropriation of private assets, trafficking and the imposition of taxes or other charges by governments, as well as health and safety concerns. The occurrence of any of these events in markets served by us now or in the future and the resulting instability may have a material adverse effect on our business, results of operations and financial condition.

We emphasize compliance with all applicable laws and regulations in all jurisdictions where we operate and have implemented and continue to implement and refresh policies, procedures and certain ongoing training of our employees, third-party providers and partners with regard to business ethics and key legal requirements; however, we cannot assure you that our employees, third-party providers or partners will adhere to our code of ethics, other policies or other legal requirements. If we fail to enforce our policies and procedures properly or maintain adequate recordkeeping and internal accounting practices to record our transactions accurately, we may be subject to sanctions. In the event we believe or have reason to believe our employees, third-party providers or partners have or may have violated applicable laws or regulations, we may incur investigation costs, potential penalties and other related costs, which in turn may materially adversely affect our reputation and could have a material adverse effect on our business, results of operations and financial condition.

***Increases in insurance costs or reductions in insurance coverage may have a material adverse effect on our business, results of operations and financial condition.***

If any of our aircraft were to be involved in a significant accident or if our property or operations were to be affected by a significant natural catastrophe or other event, we could be exposed to material liability or loss. If we are unable to obtain sufficient insurance (including aviation hull and liability insurance and property and business interruption coverage) to cover such liabilities or losses, whether due to insurance market conditions or otherwise, our business could be materially adversely affected.

We currently obtain third-party war risk (terrorism) insurance as part of our commercial aviation hull and liability policy and additional third-party war risk (terrorism) insurance through a separate policy with a different private insurance company. Our current war risk insurance from commercial underwriters excludes nuclear, radiological and certain other events. The global insurance market for aviation-related risks has been faced with significant losses, resulting in substantial tightening in insurance markets with reduced capacity and increased prices. If we are unable to obtain adequate third-party hull and liability or third-party war risk (terrorism) insurance or if an event not covered by the insurance we maintain were to take place, our business could be materially adversely affected.

***The airline industry is heavily taxed.***

The airline industry is subject to extensive government fees and taxation that negatively impact our revenue and profitability. The U.S. airline industry is one of the most heavily taxed of all industries. These fees and taxes have grown significantly in the past decade for domestic flights, and various U.S. fees and taxes also are assessed on international flights. For example, as permitted by federal legislation, most major U.S. airports impose a

## Table of Contents

passenger facility charge per passenger on us. In addition, the governments of foreign countries in which we operate impose on U.S. airlines, including us, various fees and taxes, and these assessments have been increasing in number and amount in recent years. Moreover, we are obligated to collect a federal excise tax, commonly referred to as the “ticket tax,” on domestic and international air transportation. We collect the excise tax, along with certain other U.S. and foreign taxes and user fees on air transportation (such as passenger security fees), and pass along the collected amounts to the appropriate governmental agencies. Although these taxes and fees are not our operating expenses, they represent an additional cost to our customers, which, because we operate in a highly elastic environment, drives down demand. There are continuing efforts in Congress and in other countries to raise different portions of the various taxes, fees, and charges imposed on airlines and their passengers, including the passenger facility charge, and we may not be able to recover all of these charges from our customers. Increases in such taxes, fees and charges could negatively impact our business, results of operations and financial condition.

Under regulations set forth by the Department of Transportation, or the DOT, all governmental taxes and fees must be included in the prices we quote or advertise to our customers. Due to the competitive revenue environment, many increases in these fees and taxes have been absorbed by the airline industry rather than being passed on to the customer. Further increases in fees and taxes may reduce demand for air travel, and thus our revenues.

***Restrictions on or increased taxes applicable to charges for ancillary products and services paid by airline passengers and burdensome consumer protection regulations or laws could harm our business, results of operations and financial condition.***

For the years ended December 31, 2019 and 2018, we generated ancillary revenues of \$        million and \$56.7 million, respectively. Our ancillary revenue consists primarily of revenue generated from air travel-related services such as baggage fees, seat selection and upgrade fees, itinerary service fees, on-board sales and sales of trip insurance. The DOT has rules governing many facets of the airline-consumer relationship, including, for instance, consumer notice requirements, handling of consumer complaints, price advertising, lengthy tarmac delays, oversales and denied boarding process/compensation, ticket refunds, liability for loss, delay or damage to baggage, customer service commitments, contracts of carriage, consumer disclosures and the transportation of passengers with disabilities. The DOT periodically audits airlines to determine whether such airlines have violated any of the DOT rules. If the DOT determines that we are not, or have not been, in compliance with these rules or if we are unable to remain compliant, the DOT may subject us to fines or other enforcement action. The DOT may also impose additional consumer protection requirements, including adding requirements to modify our websites and computer reservations system, which could have a material adverse effect on our business, results of operations and financial condition. The U.S. Congress and the DOT have examined the increasingly common airline industry practice of unbundling the pricing of certain products and ancillary services, a practice that is a core component of our business strategy. If new laws or regulations are adopted that make unbundling of airline products and services impermissible, or more cumbersome or expensive, or if new taxes are imposed on ancillary revenues, our business, results of operations and financial condition could be negatively impacted. Congressional, Federal agency and other government scrutiny may also change industry practice or the public’s willingness to pay for ancillary services. See also “—*We are subject to extensive regulation by the FAA, the DOT, the TSA, CBP and other U.S. and foreign governmental agencies, compliance with which could cause us to incur increased costs and adversely affect our business, results of operations and financial condition.*”

***We are subject to risks associated with climate change, including increased regulation to reduce emissions of greenhouse gases.***

Concern about climate change and greenhouse gases may result in additional regulation or taxation of aircraft emissions in the United States and abroad. In particular, in June 2015, the Environmental Protection Agency, or the EPA, announced a proposed endangerment finding that aircraft engine greenhouse gas, or GHG, emissions cause or contribute to air pollution that may reasonably be anticipated to endanger public health or welfare. If the EPA makes a final, positive endangerment finding, the EPA is obligated under the Clean Air Act to set GHG emissions standards for aircraft. In addition, federal climate legislation, including the “Green New

## [Table of Contents](#)

Deal” resolution, has been introduced in Congress recently, although Congress has yet to pass a bill specifically addressing GHG regulation. Several states are also considering or have adopted initiatives to regulate emissions of GHGs, primarily through the planned development of GHG emissions inventories and/or regional cap-and-trade programs. On March 6, 2017, the International Civil Aviation Organization, or ICAO, an agency of the United Nations established to manage the administration and governance of the Convention on International Civil Aviation, adopted new carbon dioxide, or CO<sub>2</sub> certification standards for new aircraft beginning in 2020. The new CO<sub>2</sub> standards will apply to new aircraft type designs from 2020, and to aircraft type designs already in production as of 2023. In-production aircraft that do not meet the standard by 2028 will no longer be able to be produced unless their designs are modified to meet the new standards.

In addition, in October 2016, the ICAO adopted the Carbon Offsetting and Reduction Scheme for International Aviation, or CORSIA, which is a global, market-based emissions offset program designed to encourage carbon-neutral growth beyond 2020. Further, in June 2018 the ICAO adopted standards pertaining to the collection and sharing of information on international aviation emissions beginning in 2019. The CORSIA will increase operating costs for us and other U.S. airlines that operate internationally. The CORSIA is being implemented in phases, with information sharing beginning in 2019 and a pilot phase beginning in 2021. Certain details are still being developed and the impact cannot be fully predicted. The potential impact of the CORSIA or other emissions-related requirements on our costs will ultimately depend on a number of factors, including baseline emissions, the price of emission allowances or offsets that we would need to acquire, the efficiency of our fleet and the number of flights subject to these requirements. These costs have not been completely defined and could fluctuate.

In the event that legislation or regulation with respect to GHG emissions associated with aircraft or applicable to the fuel industry is enacted in the United States or other jurisdictions where we operate or where we may operate in the future, or as part of international conventions to which we are subject, it could result in significant costs for us and the airline industry. In addition to direct costs, such regulation may have a greater effect on the airline industry through increases in fuel costs that could result from fuel suppliers passing on increased costs that they incur under such a system.

### ***We face competition from air travel substitutes.***

In addition to airline competition from legacy network airlines, LCCs and ULCCs, we also face competition from air travel substitutes. Our business serves primarily leisure travelers, for whom travel is entirely discretionary. On our domestic routes, particularly those with shorter stage lengths, we face competition from some other transportation alternatives, such as bus, train or automobile. In addition, technology advancements may limit the demand for air travel. For example, video conferencing and other methods of electronic communication may reduce the need for in-person communication and add a new dimension of competition to the industry as travelers seek lower-cost substitutes for air travel. If we are unable to stimulate demand for air travel with our low base fares or if we are unable to adjust rapidly in the event the basis of competition in our markets changes, it could have a material adverse effect on our business, results of operations and financial condition.

### **Risks Related to Our Business**

#### ***If we fail to implement our business strategy successfully, our business will be materially adversely affected.***

Our business strategy includes growth in our aircraft fleet, expansion of markets we serve by building out our MSP hub and growing non-MSP point-to-point markets, increasing the seats in each aircraft, expanding our ancillary product offering and growing our charter service. When developing our route network, we focus on gaining market share on routes that have been underserved or are served primarily by higher cost airlines where we have a competitive cost advantage. Effectively implementing our growth strategy is critical for our business to achieve economies of scale and to sustain or increase our profitability. We face numerous challenges in implementing our growth strategy, including our ability to:

- sustain our relatively low unit costs, continue to realize attractive revenue performance and maintain profitability;

## Table of Contents

- stimulate traffic with low fares;
- maintain an optimal level of aircraft utilization to execute our scheduled and charter operations;
- access airports located in our targeted geographic markets; and
- maintain operational performance necessary to complete all flights.

If we are unable to obtain and maintain access to a sufficient number of slots, gates or related ground facilities at desirable airports to accommodate our growing fleet, we may be unable to compete in desirable markets, our aircraft utilization rate could decrease, and we could suffer a material adverse effect on our business, results of operations and financial condition.

Our growth is also dependent upon our ability to maintain a safe and secure operation and will require additional personnel, equipment and facilities as we induct new aircraft and continue to execute our growth plan. In addition, we will require additional third-party personnel for services we do not undertake ourselves. An inability to hire and retain personnel, timely secure the required equipment and facilities in a cost-effective manner, efficiently operate our expanded facilities or obtain the necessary regulatory approvals may adversely affect our ability to achieve our growth strategy, which could harm our business. Furthermore, expansion to new markets may have other risks due to factors specific to those markets. We may be unable to foresee all of the existing risks upon entering certain new markets or respond adequately to these risks, and our growth strategy and our business may suffer as a result. In addition, our competitors may reduce their fares and/or offer special promotions following our entry into a new market and may also offer more attractive frequent flyer programs and/or access to marketing alliances with other airlines, which we do not currently offer. We cannot assure you that we will be able to profitably expand our existing markets or establish new markets.

### ***The anticipated strategic and financial benefits of the ATSA may not be realized.***

In December 2019, we entered into the ATSA with Amazon with the expectation that the transactions contemplated thereby would result in various benefits including, among others, growth in revenues, improved cash flows and operating efficiencies. Achieving the anticipated benefits from the ATSA is subject to a number of challenges and uncertainties, such as: potential delays in the completion of required aircraft modifications, including as a result of operational interruptions in China related to the ongoing novel coronavirus (2019-nCoV) outbreak; unforeseen maintenance and other costs; our ability to hire pilots, crew and other personnel necessary to support the Amazon operations; delays in the commencement of operations under the ATSA or interruptions in the operations under the ATSA as a result of unexpected or unforeseen events, whether as a result of factors within the Company's control or outside of the Company's control; and the level of operations and results of operations, including margins, under the ATSA being less than the Company's current expectations and projections. We have not historically had any significant cargo operations, nor have we had main deck cargo operations. Applying our existing business strategies to cargo operations may be costly, complex and time-consuming, and our management will have to devote substantial time and resources to such effort and it may not be successful. We may also experience difficulties or delays in securing gate access and other airport services necessary to operate in the air cargo and express shipping sector. If we are unable to successfully implement the Amazon operations and achieve our objectives, the expected benefits may be only partially realized or not at all, or may take longer to realize than expected. There can be no assurances that the ATSA or our relationship with Amazon will benefit our financial condition or results of operations, and we will incur costs related to the relationship, including related to the 2019 Warrants, that could have a negative impact on our results of operations if not offset by benefits from the ATSA. In addition, if we fail to perform under the terms and conditions of the contract, we may be required to pay fees or penalties to Amazon and, in certain cases, Amazon may have the right to terminate the agreement. The ATSA is also subject to two, two-year extension options, which Amazon may choose not to exercise. Importantly, Amazon has not agreed to any minimum flying requirements under the ATSA and could choose not to fly significant volumes with us. Moreover, we plan to decrease our scheduled service operations for the summer of 2020 to divert more resources towards the Amazon operations during the ramp-up period, which is expected to extend through the fourth quarter of 2020 but which could be longer, and accordingly our results for scheduled service operations will be adversely affected as we



## [Table of Contents](#)

implement our Amazon operations. If we do not achieve the benefits we expect from our Amazon operations to offset the impact on our scheduled passenger service and charter operations, we could suffer from a material adverse effect on our financial condition and results of operations.

***Our low-cost structure is one of our primary competitive advantages, and many factors could affect our ability to control our costs.***

Our low-cost structure is one of our primary competitive advantages. However, we have limited control over many of our costs. For example, we have limited control over the price and availability of aircraft fuel, aviation insurance, the acquisition and cost of aircraft, airport and related infrastructure costs, taxes, the cost of meeting changing regulatory requirements, the cost of capable talent at market wages and our cost to access capital or financing. In addition, the compensation and benefit costs applicable to a significant portion of our employees are established by the terms of collective bargaining agreements, substantially all of which are currently open and are being negotiated. See “—*Increased labor costs, union disputes, employee strikes and other labor-related disruption may adversely affect our business, results of operations and financial condition.*” We cannot guarantee we will be able to maintain our relatively low costs. If our cost structure increases and we are no longer able to maintain a competitive cost structure, it could have a material adverse effect on our business, results of operations and financial condition.

***Our business is significantly tied to and consolidated in our main hub in Minneapolis-St. Paul, and any decrease in traffic in this hub could have a material adverse effect on our business, operations, financial condition and brand.***

Our service is concentrated around our hub in MSP and our business is impacted by economic and geophysical factors of this region. We maintain a large presence in MSP with approximately 81% of flights in 2019 having MSP as either their origin or destination. Flight operations in Minneapolis can face extreme weather challenges in all seasons but especially in the winter which at times has resulted in severe disruptions in our operation and the incurrence of material costs as a consequence of such disruptions. Our business could be further harmed by an increase in the amount of direct competition we face in the Minneapolis market or by continued or increased congestion, delays or cancellations. For instance, MSP is also a significant hub for Delta Air Lines. If Delta Air Lines or another legacy network airline were to successfully develop low-cost or low-fare products or if we were to experience increased competition from LCCs or ULCCs in the Minneapolis market, our business, results of operations and prospects could be materially adversely affected.

Our business would also be negatively impacted by any circumstances causing a reduction in demand for air transportation in the Minneapolis area, such as adverse changes in local economic conditions, health concerns, adverse weather conditions, negative public perception of Minneapolis, terrorist attacks or significant price or tax increases linked to increases in airport access costs and fees imposed on passengers.

We have third-party vendors that support our MSP operations and we cannot guarantee that these vendors will operate to our expectations. We currently operate out of Terminal 2 at MSP. Our access to use our existing gates and other facilities in Terminal 2 is not guaranteed. We cannot assure you that our continued use of our facilities at MSP will occur on acceptable terms with respect to operations and cost of operations, or at all, or that our ongoing use of these facilities will not include additional or increased fees.

***Our reputation and business could be adversely affected in the event of an accident or similar public incident involving our aircraft or personnel.***

We are exposed to potential significant losses and adverse publicity in the event that any of our aircraft or personnel is involved in an accident, terrorist incident or other similar public incident, which could expose us to significant reputational harm and potential legal liability. In addition, we could face significant costs related to repairs or replacement of a damaged aircraft and its temporary or permanent loss from service. We cannot assure you that we will not be affected by such events or that the amount of our insurance coverage will be adequate in the event such circumstances arise and any such event could cause a substantial increase in our insurance premiums. In addition, any future accident or similar incident involving our aircraft or personnel, even if fully covered by insurance or even if it does not involve our airline, may create an adverse public perception about our



## [Table of Contents](#)

airline or that the equipment we fly is less safe or reliable than other transportation alternatives, or, in the case of our aircraft, could cause us to perform time-consuming and costly inspections on our aircraft or engines, any of which could have a material adverse effect on our business, results of operations and financial condition.

In addition, any accident involving the Boeing 737-NG or an aircraft similar to the Boeing 737-NG that we operate could result in the curtailment of such aircraft by aviation regulators, manufacturers and other airlines and could create a negative public perception about the safety of our aircraft, any of which could have a material adverse effect on our business, results of operations and financial condition. For example, in 2019, certain global aviation regulators and airlines grounded the Boeing 737 MAX in response to accidents involving aircraft flown by Lion Air and Ethiopian Airlines. In addition, following a 2018 accident involving the failure of a turbofan on a 737-700 aircraft, the National Transportation Safety Board, or NTSB, has recommended that regulators require Boeing to redesign the engine cowl on 737-NG aircraft and retrofit in service 737-NG aircraft with the redesigned cowl. We cannot predict when the FAA will respond to the NTSB recommendations and if it will require us to replace the engine cowls in our aircraft, which may be time-consuming and costly. The resolution of this matter or similar matters in the future could have an impact on our results of operations, financial condition, business and prospects.

***Unauthorized breach of our information technology infrastructure could compromise the personally identifiable information of our passengers, prospective passengers or personnel and expose us to liability, damage our reputation and have a material adverse effect on our business, results of operations and financial condition.***

In the processing of our customer transactions and as part of our ordinary business operations, we and certain of our third-party providers collect, process, transmit and store a large volume of personally identifiable information, including email addresses and home addresses and financial data such as credit and debit card information. This data is increasingly subject to legislation and regulation, such as the Fair Accurate Credit Transparency Act, Payment Card Industry legislation, the California Consumer Privacy Act and the European Union's General Data Protection Regulation typically intended to protect the privacy of personal data that is collected, processed, stored and transmitted. The security of the systems and network where we and our third-party providers store this data is a critical element of our business, and these systems and our network may be vulnerable to theft, loss, damage and interruption from a number of potential sources and events, including computer viruses, hackers, denial-of-service attacks, employee theft or misuse, natural or man-made disasters, telecommunications failures, power loss and other disruptive sources and events. As the cyber-threat landscape evolves, attacks are growing in frequency, sophistication and intensity, and are becoming increasingly difficult to detect. We may not have the resources or technical sophistication to anticipate or prevent rapidly evolving types of cyber attacks. Attacks may be targeted at us, our customers and our providers, including air navigation service providers, or others who have entrusted us with information, including regulators such as the FAA and DOT. In addition, attacks not targeted at us, but targeted solely at providers, may cause disruption to our computer systems or a breach of the data that we maintain on customers, employees, providers and others. Recently, several high profile consumer-oriented companies have experienced significant data breaches, which have caused those companies to suffer substantial financial and reputational harm. We cannot assure you that the precautions we have taken to avoid an unauthorized incursion of our computer systems are either adequate or implemented properly to prevent a data breach and its adverse financial and reputational consequences to our business. The compromise of our technology systems resulting in the loss, disclosure, misappropriation of or access to the personally identifiable information of our passengers, prospective passengers or personnel could result in governmental investigation, civil liability or regulatory penalties under laws protecting the privacy of personal information, and our reputation could be harmed, any or all of which could disrupt our operations and have a material adverse effect on our business, results of operations and financial condition.

Additionally, any material failure by us or our third-party providers to maintain compliance with the Payment Card Industry security requirements or to rectify a data security issue may result in fines and restrictions on our ability to accept credit and debit cards as a form of payment. Actual or anticipated attacks may cause us to incur increasing costs, including costs to deploy additional personnel and protection technologies, train employees and engage third-party experts and consultants, or costs incurred in connection with the notifications

## [Table of Contents](#)

to customers, employees, providers or the general public as part of our notification obligations to the various governments that govern our business. In addition, data and security breaches can also occur as a result of non-technical issues, including breaches by us or by persons with whom we have commercial relationships that result in the unauthorized release of personal or confidential information.

We are subject to increasing legislative, regulatory and customer focus on privacy issues and data security in the United States and abroad. In addition, a number of our commercial partners, including credit card companies, have imposed data security standards on us, and these standards continue to evolve. We will continue our efforts to meet our privacy and data security obligations; however, it is possible that certain new obligations may be difficult to meet and could increase our costs. Additionally, we must manage evolving cybersecurity risks. The loss, disclosure, misappropriation of or access to the information of our customers, personnel or business partners or any failure by us to meet our obligations could result in legal claims or proceedings, liability or regulatory penalties.

### ***We rely on third-party providers and other commercial partners to perform functions integral to our operations.***

We have entered into agreements with third-party providers to furnish certain facilities and services required for our operations, including ground handling, catering, passenger handling, engineering, maintenance, refueling, reservations and airport facilities as well as administrative and support services. We are likely to enter into similar service agreements in new markets we decide to enter, and we cannot assure you that we will be able to obtain the necessary services at acceptable rates. Certain of these providers are an integral part of our operations at our main hub in MSP.

Although we seek to monitor the performance of third parties that furnish certain facilities or provide us with our ground handling, catering, passenger handling, engineering, maintenance, refueling, reservations and airport facilities, the efficiency, timeliness and quality of contract performance by third-party providers are often beyond our control, and any failure by our third-party providers to perform up to our expectations may have an adverse impact on our business, reputation with customers, our brand and our operations. These service agreements are generally subject to termination after notice by the third-party providers. In addition, we could experience a significant business disruption if we were to change vendors or if an existing provider ceased to be able to serve us. We expect to be dependent on such third-party arrangements for the foreseeable future.

### ***We rely on third-party distribution channels to distribute a portion of our airline tickets.***

We rely on third-party distribution channels, including those provided by or through global distribution systems, or GDSs, conventional travel agents and online travel agents, or OTAs, to distribute a significant portion of our airline tickets, and we expect in the future to rely on these channels to also collect a portion of our ancillary revenues. These distribution channels are more expensive and at present have less functionality in respect of ancillary revenues than those we operate ourselves, such as our website. Certain of these distribution channels also effectively restrict the manner in which we distribute our products generally. To remain competitive, we will need to successfully manage our distribution costs and rights, and improve the functionality of third-party distribution channels, while maintaining an industry-competitive cost structure. Negotiations with key GDSs and OTAs designed to manage our costs, increase our distribution flexibility, and improve functionality could be contentious, could result in diminished or less favorable distribution of our tickets, and may not provide the functionality we require to maximize ancillary revenues. In addition, in the last several years there has been significant consolidation among GDSs and OTAs. This consolidation and any further consolidation could affect our ability to manage our distribution costs due to a reduction in competition or other industry factors. Any inability to manage such costs, rights and functionality at a competitive level or any material diminishment in the distribution of our tickets could have a material adverse effect on our competitive position and our results of operations. Moreover, our ability to compete in the markets we serve may be threatened by changes in technology or other factors that may make our existing third-party sales channels impractical, uncompetitive or obsolete.

***We rely heavily on technology and automated systems to operate our business, and any disruptions or failure of these technologies or systems or any failure on our part to implement any new technologies or systems could materially adversely affect our business.***

We are highly dependent on technology and computer systems and networks to operate our business. These technologies and systems include our computerized airline reservation system provided by *Navitaire*, a unit of Amadeus, flight operations systems, telecommunications systems, mobile phone application, airline website and maintenance systems. In order for our operations to work efficiently, our website and reservation system must be able to accommodate a high volume of traffic, maintain secure information and deliver flight information. Our reservations system, which is hosted and maintained under a long-term contract by a third-party provider, is critical to our ability to issue, track and accept electronic tickets, conduct check-in, board and manage our passengers through the airports we serve and provide us with access to GDSs, which enlarge our pool of potential passengers. There are many instances in the past where a reservations system malfunctioned, whether due to the fault of the system provider or the airline, with a highly adverse effect on the airline's operations, and such a malfunction has in the past and could in the future occur on our system, or in connection with any system upgrade or migration in the future. We also rely on third-party providers to maintain our flight operations systems, and if those systems are not functioning, we could experience service disruptions, which could result in the loss of important data, increase our expenses, decrease our operational performance and temporarily stall our operations.

Any failure of the technologies and systems we use could materially adversely affect our business. In particular, if our reservation system fails or experiences interruptions, and we are unable to book seats for a period of time, we could lose a significant amount of revenue as customers book seats on other airlines, and our reputation could be harmed. In addition, replacement technologies and systems for any service we currently utilize that experiences failures or interruptions may not be readily available on a timely basis, at competitive rates or at all. Furthermore, our current technologies and systems are heavily integrated with our day-to-day operations and any transition to a new technology or system could be complex and time-consuming. Our technologies and systems cannot be completely protected against events that are beyond our control, including natural disasters, cyber attacks or telecommunications failures. Substantial or sustained disruptions or system failures could cause service delays or failures and result in our customers purchasing tickets from other airlines. We cannot assure you that any of our security measures, change control procedures or disaster recovery plans that we have implemented are adequate to prevent disruptions or failures. In the event that one or more of our primary technology or systems vendors fails to perform and a replacement system is not available or if we fail to implement a replacement system in a timely and efficient manner, our business could be materially adversely affected.

In addition, in the ordinary course of business, our systems will continue to require modification and refinements to address growth and changing business requirements and to enable us to comply with changing regulatory requirements. Modifications and refinements to our systems have been and are expected to continue to be expensive to implement and can divert management's attention from other matters. Furthermore, our operations could be adversely affected, or we could face impositions of regulatory penalties, if we were unable to timely or effectively modify our systems as necessary or appropriately balance the introduction of new capabilities with the management of existing systems.

***We may not be able to grow or maintain our unit revenues or maintain our ancillary revenues.***

A key component of our strategy was establishing Sun Country as a premier high-growth, low-cost carrier in the United States by attracting customers with low fares and garnering repeat business by delivering a high-quality customer experience with additional free amenities than traditionally provided on ULCCs in the United States. We intend to continue to differentiate our brand and product in order to expand our loyal customer base and grow or maintain our unit revenues and maintain our ancillary revenues. Differentiating our brand and product has required and will continue to require significant investment, and we cannot assure you that the initiatives we have implemented will continue to be successful or that the initiatives we intend to implement will

## [Table of Contents](#)

be successful. If we are unable to maintain or further differentiate our brand and product from LCCs or ULCCs, our market share could decline, which could have a material adverse effect on our business, results of operations and financial condition. We may also not be successful in leveraging our brand and product to stimulate new demand with low base fares or gain market share from the legacy network airlines.

In addition, our business strategy includes maintaining our portfolio of desirable, value-oriented, ancillary products and services. However, we cannot assure you that passengers will continue to perceive value in the ancillary products and services we currently offer and regulatory initiatives could adversely affect ancillary revenue opportunities. Failure to maintain our ancillary revenues would have a material adverse effect on our business, results of operations and financial condition. Furthermore, if we are unable to maintain our ancillary revenues, we may not be able to execute our strategy to continue to lower base fares in order to stimulate demand for air travel.

### ***We operate a single aircraft type.***

A critical cost-saving element of our business strategy is to operate a single-family aircraft fleet; however, our dependence on the Boeing 737-NG aircraft and CFM56 engines for all of our aircraft makes us vulnerable to any design defects or mechanical problems associated with this aircraft type or these engines. In the event of any actual or suspected design defects or mechanical problems with these family aircraft or engines, whether involving our aircraft or that of another airline, we may choose or be required to suspend or restrict the use of our aircraft. For example, several Boeing 737-NG aircraft have recently been grounded by other airlines after inspections revealed cracks in the “pickle forks,” a component of the structure connecting the wings to the fuselages. Our business could also be materially adversely affected if the public avoids flying on our aircraft due to an adverse perception of the Boeing 737-NG aircraft or CFM56 engines, whether because of safety concerns or other problems, real or perceived, or in the event of an accident involving such aircraft or engines. Additionally, while we do not operate the Boeing 737 MAX, the grounding of that fleet has led to increased competition for near term leases for other Boeing 737 aircraft.

### ***Increased labor costs, union disputes, employee strikes and other labor-related disruption may adversely affect our business, results of operations and financial condition.***

Our business is labor intensive, with labor costs representing approximately % and 23.2% of our total operating costs for the years ended December 31, 2019 and 2018, respectively. As of December 31, 2019, approximately 59% of our workforce was represented by labor unions. We cannot assure you that our labor costs going forward will remain competitive or that any new agreements into which we enter will not have terms with higher labor costs or that the negotiations of such labor agreements will not result in any work stoppages. In addition, one or more of our competitors may significantly reduce their labor costs, thereby providing them with a competitive advantage over us. Furthermore, our labor costs may increase in connection with our growth. We may also become subject to additional collective bargaining agreements in the future as non-unionized workers may unionize.

Relations between air carriers and labor unions in the United States are governed by the Railway Labor Act, or the RLA. Under the RLA, collective bargaining agreements generally contain “amendable dates” rather than expiration dates, and the RLA requires that a carrier maintain the existing terms and conditions of employment following the amendable date through a multi-stage and usually lengthy series of bargaining processes overseen by the National Mediation Board, or the NMB. This process continues until either the parties have reached agreement on a new collective bargaining agreement, or the parties have been released to “self-help” by the NMB. In most circumstances, the RLA prohibits strikes; however, after release by the NMB, carriers and unions are free to engage in self-help measures such as lockouts and strikes.

Our collective bargaining agreement with our dispatchers became amendable on September 27, 2017 and we entered into NMB mediation with the union representing this group on September 19, 2018. On December 3, 2019 our dispatchers approved a new contract, now amendable on November 14, 2024. Our collective bargaining

## Table of Contents

agreement with our flight attendants is currently amendable and we are in negotiations with the union representing this group. Our collective bargaining agreement with our pilots is amendable on October 31, 2020. See also “*Business—Employees.*” The outcome of our collective bargaining negotiations cannot presently be determined and the terms and conditions of our future collective bargaining agreements may be affected by the results of collective bargaining negotiations at other airlines that may have a greater ability, due to larger scale, greater efficiency or other factors, to bear higher costs than we can. In addition, if we are unable to reach agreement with any of our unionized work groups in current or future negotiations regarding the terms of their collective bargaining agreements, we may be subject to work interruptions, stoppages or shortages. Any such action or other labor dispute with unionized employees could disrupt our operations, reduce our profitability or interfere with the ability of our management to focus on executing our business strategies. As a result, our business, results of operations and financial condition may be materially adversely affected based on the outcome of our negotiations with the unions representing our employees.

***Changes in law, regulation and government policy have affected, and may in the future have a material adverse effect on our business.***

Changes in, and uncertainty with respect to, law, regulation and government policy at the local, state or federal level have affected, and may in the future significantly impact, our business and the airline industry. For example, the Tax Cuts and Jobs Act, enacted on December 22, 2017, limits deductions for borrowers for net interest expense on debt. Changes to law, regulations or government policy that could have a material impact on us in the future include, but are not limited to, infrastructure renewal programs; changes to operating and maintenance requirements; foreign and domestic changes in customs, immigration and security policy and requirements that impede travel into or out of the United States; modifications to international trade policy, including withdrawing from trade agreements and imposing tariffs; changes to consumer protection laws; changes to financial legislation, including the partial or full repeal of the Dodd-Frank Wall Street Reform and Consumer Protection Act of 2010, or Dodd-Frank Act; public company reporting requirements; environmental regulation and antitrust enforcement. Any such changes could make it more difficult and/or more expensive for us to obtain new aircraft or engines and parts to maintain existing aircraft or engines or make it less profitable or prevent us from flying to or from some of the destinations we currently serve.

To the extent that any such changes have a negative impact on us or the airline industry, including as a result of related uncertainty, these changes may materially and adversely impact our business, financial condition, results of operations and cash flows.

***We rely on efficient daily aircraft utilization to address peak demand days of the week and months of the year, which makes us vulnerable to flight delays, flight cancellations or aircraft unavailability.***

We aim to optimize our daily aircraft utilization rate by tailoring service to customer demand patterns, which are seasonal and vary by day of the week. Our average daily aircraft utilization was 9.6 hours and 9.7 hours for the years ended December 31, 2019 and 2018, respectively. Aircraft utilization is the average amount of time per day that our aircraft spend carrying passengers. Part of our business strategy is to efficiently deploy our aircraft, which is achieved in part by higher utilization during the most profitable seasonal periods and days of the week and more limited usage of less expensive aircraft during weak demand periods. Aircraft utilization is reduced by delays and cancellations from various factors, many of which are beyond our control, including air traffic congestion at airports or other air traffic control problems or outages, adverse weather conditions, increased security measures or breaches in security, international or domestic conflicts, terrorist activity, or other changes in business conditions. In addition, pulling aircraft out of service for unscheduled and scheduled maintenance may materially reduce our average fleet utilization or make high cost aircraft unavailable for use and require that we reaccommodate passengers or seek short-term substitute capacity at increased costs, especially since we do not have reaccommodation arrangements with other airlines like legacy network airlines do and cannot reaccommodate passengers on our aircraft because of our limited schedule. Due to the relatively small size of our fleet and the limited and changing nature of our scheduled service and our point-to-point network, the unexpected unavailability of one or more aircraft and resulting reduced capacity could have a material adverse effect on our business, results of operations and financial condition.

***If we are unable to attract and retain qualified personnel at reasonable costs or fail to maintain our company culture, our business could be harmed.***

Our business is labor intensive. We require large numbers of pilots, flight attendants, maintenance technicians and other personnel. We compete against other U.S. airlines for pilots, mechanics and other skilled labor and certain U.S. airlines offer wage and benefit packages exceeding ours. The airline industry has from time to time experienced a shortage of qualified personnel. In particular, as more pilots in the industry approach mandatory retirement age, the U.S. airline industry is being affected by a pilot shortage. We and other airlines are also facing shortages of qualified aircraft mechanics and dispatchers. As is common with most of our competitors, we have faced considerable turnover of our employees. As a result of the foregoing, we may not be able to attract or retain qualified personnel or may be required to increase wages and/or benefits in order to do so. If we are unable to hire, train and retain qualified employees, our business could be harmed and we may be unable to implement our growth plans.

In addition, as we hire more people and grow, we believe it may be increasingly challenging to continue to hire people who will maintain our company culture. Our company culture, which we believe is one of our competitive strengths, is important to providing dependable customer service and having a productive, accountable workforce that helps keep our costs low. As we continue to grow, we may be unable to identify, hire or retain enough people who meet the above criteria, including those in management or other key positions. Our company culture could otherwise be adversely affected by our growing operations and geographic diversity. If we fail to maintain the strength of our company culture, our competitive ability and our business, results of operations and financial condition could be harmed.

***Our inability to expand or operate reliably or efficiently out of airports where we operate could have a material adverse effect on our business, results of operations and financial condition and brand.***

Our results of operations may be affected by actions taken by governmental or other agencies or authorities having jurisdiction over our operations at these airports, including, but not limited to:

- increases in airport rates and charges;
- limitations on take-off and landing slots, airport gate capacity or other use of airport facilities;
- termination of our airport use agreements, some of which can be terminated by airport authorities with little notice to us;
- increases in airport capacity that could facilitate increased competition;
- international travel regulations such as customs and immigration;
- increases in taxes;
- changes in law, regulations and government policies that affect the services that can be offered by airlines, in general, and in particular markets and at particular airports;
- restrictions on competitive practices;
- the adoption of statutes or regulations that impact or impose additional customer service standards and requirements, including operating and security standards and requirements; and
- the adoption of more restrictive locally imposed noise regulations or curfews.

Our business is highly dependent on the availability and cost of airport services at the airports where we operate. Any changes in airport operations could have a material adverse effect on our business, results of operations and financial condition.

***It has only been a limited period since our current business and operating strategy has been implemented.***

Following the implementation of our current business and operating strategy in late 2017 and our acquisition by the Apollo Funds in 2018, we recorded net income of \$        million, a net loss of \$367 thousand

## Table of Contents

and net income of \$25.9 million for the Successor 2019 period, Successor 2018 period and Predecessor 2018 period, respectively, which are better operating results than we had previously achieved. While we recorded an annual profit for the years ended December 31, 2019 and 2018, we cannot assure you that we will be able to sustain or increase profitability on a quarterly or an annual basis. In turn, this may materially adversely affect our business.

### ***We are subject to various environmental and noise laws and regulations, which could have a material adverse effect on our business, results of operations and financial condition.***

We are subject to increasingly stringent federal, state, local and foreign laws, regulations and ordinances relating to the protection of the environment and noise, including those relating to emissions to the air (including air emissions associated with the operation of our aircraft), discharges (including storm water discharges) to surface and subsurface waters, safe drinking water and the use, management, disposal and release of, and exposure to, hazardous substances, oils and waste materials. We are or may be subject to new or amended laws and regulations that may have a direct effect (or indirect effect through our third-party providers, including the petroleum industry, or airport facilities at which we operate) on our operations. In addition, U.S. airport authorities are exploring ways to limit de-icing fluid discharges. Any such existing, future, new or potential laws and regulations could have an adverse impact on our business, results of operations and financial condition.

Similarly, we are subject to environmental laws and regulations that require us to investigate and remediate soil or groundwater to meet certain remediation standards. Under certain laws current and former owners or operators of facilities, as well as generators of waste materials disposed of at such facilities, can be subject to liability for investigation and remediation costs at facilities that have been identified as requiring response actions. Liability under these laws may be strict, joint and several, meaning that we could be liable for the costs of cleaning up environmental contamination regardless of fault or compliance with applicable law when the disposal occurred or the amount of wastes directly attributable to us.

In addition, the ICAO and jurisdictions around the world have adopted noise regulations that require all aircraft to comply with noise level standards, and governmental authorities in several U.S. and foreign cities are considering or have already implemented aircraft noise reduction programs, including the imposition of overnight curfews and limitations on daytime take-offs and landings. Compliance with existing and future environmental laws and regulations, including emissions limitations and more restrictive or widespread noise regulations, that may be applicable to us could require significant expenditures, increase our cost base and have a material adverse effect on our business, results of operations and financial condition, and violations thereof can lead to significant fines and penalties, among other sanctions.

We participate with other airlines in fuel consortia and fuel committees at our airports where economically beneficial, which agreements generally include cost-sharing provisions and environmental indemnities that are generally joint and several among the participating airlines. Any costs (including remediation and spill response costs) incurred by such fuel consortia could also have an adverse impact on our business, results of operations and financial condition.

### ***Our intellectual property rights, particularly our branding rights, are valuable, and any inability to protect them may adversely affect our business and financial results.***

We consider our intellectual property rights, particularly our branding rights such as our trademarks applicable to our airline and Sun Country Rewards program, to be a significant and valuable aspect of our business. We aim to protect our intellectual property rights through a combination of trademark, copyright and other forms of legal protection, contractual agreements and policing of third-party misuses of our intellectual property, but cannot guarantee that such efforts will be successful. Our failure to obtain or adequately protect our intellectual property or any change in law that lessens or removes the current legal protections of our intellectual property may diminish our competitiveness and adversely affect our business and financial results. Any litigation or disputes regarding intellectual property may be costly and time-consuming and may divert the attention of our



## [Table of Contents](#)

management and key personnel from our business operations, either of which may adversely affect our business and financial results.

***Negative publicity regarding our customer service could have a material adverse effect on our business, results of operations and financial condition.***

Our business strategy includes the differentiation of our brand and product from the other U.S. airlines, including LCCs and ULCCs, in order to increase customer loyalty and drive future ticket sales. We intend to accomplish this by continuing to offer passengers dependable customer service. However, in the past, we have experienced customer complaints related to, among other things, product and pricing changes related to our business strategy and customer service. In particular, we have generally experienced a higher volume of complaints when we implemented changes to our unbundling policies, such as charging for seats and baggage. These complaints, together with reports of lost baggage, delayed and cancelled flights, and other service issues, are reported to the public by the DOT. In addition, we could become subject to complaints about our booking practices. If we do not meet our customers' expectations with respect to reliability and service, our brand and product could be negatively impacted, which could result in customers deciding not to fly with us and adversely affect our business and reputation. We recently entered into agreements for bus service to transport passengers to our MSP hub. If these operators suffer a service problem, safety failure or accident, our brand would be negatively impacted.

***Our reputation and brand could be harmed if we were to experience significant negative publicity, including through social media.***

We operate in a public-facing industry with significant exposure to social media. Negative publicity, whether or not justified, can spread rapidly through social media. To the extent that we are unable to respond timely and appropriately to negative publicity, our reputation and brand can be harmed. Damage to our overall reputation and brand could have a negative impact on our financial results.

***We are highly dependent upon our cash balances, operating cash flows and availability under our Asset-Based Revolving Credit Facility, or ABL Facility.***

As of December 31, 2019, our principal sources of liquidity were cash and cash equivalents of \$        million and availability under our ABL Facility of \$19.65 million. In addition, we had restricted cash of \$        million as of December 31, 2019. Restricted cash includes cash received as prepayment for chartered flights that is maintained in separate escrow accounts, from which the restrictions are released once transportation is provided. Our ABL Facility is not adequate to finance our operations, and thus we will continue to be dependent on our operating cash flows and cash balances to fund our operations, provide capital reserves and make scheduled payments on our aircraft-related fixed obligations. If we fail to generate sufficient funds from operations to meet our operating cash requirements or do not have access to availability under the ABL Facility, or other sources of borrowings or equity financing, we could default on our operating leases and fixed obligations. Our inability to meet our obligations as they become due would have a material adverse effect on our business, results of operations and financial condition.

***Our liquidity would be adversely impacted, potentially materially, in the event one or more of our credit card processors were to impose holdback restrictions for payments due to us from credit card transactions.***

We currently have agreements with organizations that process credit card transactions arising from purchases of air travel tickets by our customers. Credit card processors may have financial risk associated with tickets purchased for travel which can occur several weeks after the purchase. As of December 31, 2019, we were not subject to any credit card holdbacks under our credit card processing agreements, although if we fail to meet certain liquidity and other financial covenants, our credit card processors have the right to hold back credit card remittances to cover our obligations to them. If our credit card processors were to impose holdback restrictions on us, the negative impact on our liquidity could be significant which could have a material adverse effect on our business, results of operations and financial condition.



***Our ability to obtain financing or access capital markets may be limited.***

We have obligations to purchase aircraft and spare engines, and our current strategy is to rely on lessors or access to capital markets to provide financing for our aircraft acquisition needs. There are a number of factors that may affect our ability to raise financing or access the capital markets in the future, including our liquidity and credit status, our operating cash flows, market conditions in the airline industry, U.S. and global economic conditions, the general state of the capital markets and the financial position of the major providers of commercial aircraft financing. We cannot assure you that we will be able to source external financing for our planned aircraft acquisitions or for other significant capital needs, and if we are unable to source financing on acceptable terms, or unable to source financing at all, our business could be materially adversely affected. To the extent we finance our activities with additional debt, we may become subject to financial and other covenants that may restrict our ability to pursue our business strategy or otherwise constrain our growth and operations.

***Our maintenance costs will fluctuate over time, we will periodically incur substantial maintenance costs due to the maintenance schedules of our aircraft fleet and obligations to the lessors and we could incur significant maintenance expenses outside of such maintenance schedules in the future.***

We have substantial maintenance expense obligations, including with respect to our aircraft operating leases. Prior to an aircraft being returned in connection with an operating lease, we will incur costs to restore these aircraft to the condition required by the terms of the underlying operating leases. The amount and timing of these so-called “return conditions” costs can prove unpredictable due to uncertainty regarding the maintenance status of each particular aircraft at the time it is to be returned and it is not unusual for disagreements to ensue between the airline and the leasing company as to the required redelivery conditions on a given aircraft or engine.

Outside of scheduled maintenance, we incur from time to time unscheduled maintenance which is not forecast in our operating plan or financial forecasts, and which can impose material unplanned costs and the loss of flight equipment from revenue service for a significant period of time. For example, a single unplanned engine event can require a shop visit costing several million dollars and cause the engine to be out of service for a number of weeks.

Furthermore, the terms of our lease agreements require us to pay maintenance reserves to the lessor in advance of the performance of major maintenance, resulting in our recording significant prepaid deposits on our balance sheet, and there are restrictions on the extent to which such maintenance reserves are available for reimbursement. In addition, the terms of any lease agreements that we enter into in the future could also require maintenance reserves in excess of our current requirements. Any significant increase in maintenance and repair expenses would have a material adverse effect on our business, results of operations and financial condition. Please see “*Management’s Discussion and Analysis of Financial Condition and Results of Operations—Critical Accounting Policies and Estimates—Aircraft Maintenance.*”

***We have a significant amount of aircraft-related fixed obligations that could impair our liquidity and thereby harm our business, results of operations and financial condition.***

The airline business is capital intensive. As of December 31, 2019, our 31 aircraft fleet consisted of 16 aircraft financed under operating leases (including two seasonal leases), 10 aircraft financed under capital leases and five aircraft financed under secured debt arrangements. For the years ended December 31, 2019 and 2018, we incurred a total of \$       million and \$67.2 million, respectively, for aircraft operating lease payments, finance and capital lease payments and cash interest and principal payments related to aircraft debt. Additionally, we paid maintenance deposits of \$       million and \$31.2 million, respectively. As of December 31, 2019, we had future aircraft operating lease obligations of approximately \$       million and future principal debt obligations of \$       million, and we had future capital lease obligations of approximately \$       million. Our ability to pay the fixed costs associated with our contractual obligations will depend on our operating performance, cash flow, availability under our ABL Facility and our ability to secure adequate future financing, which will in turn depend on, among other things, the success of our current business strategy and our future financial and operating

## Table of Contents

performance, competitive conditions, fuel price volatility, any significant weakening or improving in the U.S. economy, availability and cost of financing, as well as general economic and political conditions and other factors that are, to some extent, beyond our control. The amount of our aircraft-related fixed obligations could have a material adverse effect on our business, results of operations and financial condition and could:

- require a substantial portion of cash flow from operations be used for operating lease and maintenance deposit payments and interest expense, thereby reducing the availability of our cash flow to fund working capital, capital expenditures and other general corporate purposes;
- limit our ability to obtain additional financing to support our expansion plans and for working capital and other purposes on acceptable terms or at all;
- make it more difficult for us to pay our other obligations as they become due during adverse general economic and market industry conditions because any related decrease in revenues could cause us to not have sufficient cash flows from operations to make our scheduled payments;
- reduce our flexibility in planning for, or reacting to, changes in our business and the airline industry and, consequently, place us at a competitive disadvantage to our competitors with lower fixed payment obligations; and
- cause us to lose access to one or more aircraft and forfeit our maintenance and other deposits if we are unable to make our required aircraft lease rental payments and our lessors exercise their remedies under the lease agreement, including cross-default provisions in certain of our leases.

There can be no assurance that we will be able to obtain sufficient funds to enable us to repay or refinance our debt obligations on commercially reasonable terms, or at all. A failure to pay our operating lease, debt and other fixed cost obligations or a breach of our contractual obligations, including our ABL Facility, could result in a variety of adverse consequences, including the exercise of remedies by our creditors and lessors. In such a situation, it is unlikely that we would be able to cure our breach, fulfill our obligations, make required lease payments or otherwise cover our fixed costs and our secured lenders could foreclose against the assets securing the indebtedness owing to them, which would have a material adverse effect on our business, results of operations and financial condition.

***We depend on a sole-source supplier for the majority of our aircraft parts and any supply disruption could have a material adverse effect on our business.***

We have entered into a contract with Delta Air Lines, Inc., or Delta, one of our competitors that is also the largest airline operating at MSP, for the vast majority of our aircraft parts. We are vulnerable to any problems associated with the performance of Delta's obligations to supply our aircraft parts, including design defects, mechanical problems and regulatory issues associated with engines and other parts. If Delta experiences a significant business challenge, disruption or failure due to issues such as financial difficulties or bankruptcy, regulatory or quality compliance issues, or other financial, legal, regulatory or reputational issues, ceases to produce our aircraft parts, is unable to effectively deliver our aircraft parts on timelines and at the prices we have negotiated, or terminates the contract, we would incur substantial transition costs and we would lose the cost benefits from our current arrangement with Delta, which would have a material adverse effect on our business, results of operations and financial condition.

***Reduction in demand for air transportation, or governmental reduction or limitation of operating capacity, in the domestic United States, Mexico, Caribbean or Canada markets could harm our business, results of operations and financial condition.***

A significant portion of our operations are conducted to and from the domestic United States, Mexico, Caribbean or Canada markets. Our business, results of operations and financial condition could be harmed if we lose our authority to fly to these markets, by any circumstances causing a reduction in demand for air transportation, or by governmental reduction or limitation of operating capacity, in these markets, such as adverse changes in local economic or political conditions, negative public perception of these destinations,

unfavorable weather conditions, public health concerns, civil unrest, violence or terrorist-related activities. Furthermore, our business could be harmed if jurisdictions that currently limit competition allow additional airlines to compete on routes we serve.

***We are subject to extensive regulation by the FAA, the DOT, the TSA, CBP and other U.S. and foreign governmental agencies, compliance with which could cause us to incur increased costs and adversely affect our business, results of operations and financial condition.***

Airlines are subject to extensive regulatory and legal compliance requirements, both domestically and internationally, that impose significant costs. In the last several years, Congress has passed laws and the FAA, DOT and TSA have issued regulations, orders, rulings and guidance relating to the operation, safety, and security of airlines that have required significant expenditures. We expect to continue to incur expenses in connection with complying with such laws and government regulations, orders, rulings and guidance. Additional laws, regulations, taxes and increased airport rates and charges have been proposed from time to time that could significantly increase the cost of airline operations or reduce the demand for air travel. For example, the FAA Reauthorization Act of 2018 directed the FAA to issue rules establishing minimum dimensions for passenger seats, including seat pitch, width and length. If adopted, these measures could have the effect of raising ticket prices, reducing revenue, and increasing costs.

For example, the DOT has broad authority over airlines and their consumer and competitive practices, and has used this authority to issue numerous regulations and pursue enforcement actions, including rules and fines relating to the handling of lengthy tarmac delays, consumer notice requirements, consumer complaints, price and airline advertising, distribution, oversales and involuntary denied boarding process and compensation, ticket refunds, liability for loss, delay or damage to baggage, customer service commitments, contracts of carriage and the transportation of passengers with disabilities. Among these is the series of Enhanced Airline Passenger Protection rules issued by the DOT. In addition, the adoption of FAR Part 117 in 2014 modified required pilot rest periods and work hours and Congress has enacted a law and the FAA issued regulations requiring U.S. airline pilots to have a minimum number of hours as a pilot in order to qualify for an Air Transport Pilot certificate which all pilots on U.S. airlines must obtain. Furthermore, in October 2018, Congress passed the FAA Reauthorization Act of 2018, which extends FAA funds through fiscal year 2023. The legislation contains provisions which could have effects on our results of operations and financial condition. Among other provisions, the new law requires the DOT to clarify that, with respect to a passenger who is involuntarily denied boarding as a result of an oversold flight, there is no maximum level of compensation an air carrier may pay to such passenger and the compensation levels set forth in the regulations are the minimum levels of compensation an air carrier must pay to such a passenger, and to create new requirements for the treatment of disabled passengers. In addition it provides that the maximum civil penalty amount for damage to wheelchairs and other mobility aids or for injuring a disabled passenger may be trebled. The FAA must issue rules establishing minimum dimensions for passenger seats, including seat pitch, width and length. The FAA Reauthorization Act of 2018 also establishes new rest requirements for flight attendants and requires, within one year, that the FAA issue an order requiring installation of a secondary cockpit barrier on each new aircraft. The FAA Reauthorization Act of 2018 also provides for several other new requirements and rulemakings related to airlines, including but not limited to: (i) prohibition on voice communication cell phone use during certain flights, (ii) insecticide use disclosures, (iii) new training policy best practices for training regarding racial, ethnic, and religious non-discrimination, (iv) training on human trafficking for certain staff, (v) departure gate stroller check-in, (vi) the protection of pets on airplanes and service animal standards, (vii) requirements to refund promptly to passengers any ancillary fees paid for services not received, (viii) consumer complaint process improvements, (ix) pregnant passenger assistance, (x) restrictions on the ability to deny a revenue passenger permission to board or involuntarily remove such passenger from the aircraft, (xi) minimum customer service standards for large ticket agents, (xii) information publishing requirements for widespread disruptions and passenger rights, (xiii) submission of plans pertaining to employee and contractor training consistent with the Airline Passengers with Disabilities Bill of Rights, (xiv) ensuring assistance for passengers with disabilities, (xv) flight attendant duty period limitations and rest requirements, including submission of a fatigue risk management plan, (xvi) submission of policy concerning passenger sexual misconduct and (xvii) development of Employee Assault Prevention and Response

## [Table of Contents](#)

Plan related to the customer service agents. Furthermore, in September 2019, the FAA published an Advance Notice of Proposed Rulemaking regarding flight attendant duty period limitations and rest requirements. The DOT also recently published a Notice of Proposed Rulemaking regarding, for example, the accessibility features of lavatories and onboard wheelchair requirements on certain single-aisle aircraft with an FAA certificated maximum capacity of 125 seats or more, training flight attendants to proficiency on an annual basis to provide assistance in transporting qualified individuals with disabilities to and from the lavatory from the aircraft seat, and providing certain information on request to qualified individuals with a disability or persons inquiring on their behalf, on the carrier's website, and in printed or electronic form on the aircraft concerning the accessibility of aircraft lavatories. Failure to remain in full compliance with these rules may subject us to fines or other enforcement action. FAR Part 117 and the minimum pilot hour requirements may also reduce our ability to meet flight crew staffing requirements.

***We cannot assure you that compliance with these and other laws, regulations, orders, rulings and guidance will not have a material adverse effect on our business, results of operations and financial condition.***

Compliance with the laws, regulations, orders, rulings and guidance applicable to the airline industry may increase our costs, which could have a material adverse effect on our business. For example, if our current standards do not meet the FAA's rules regarding minimum dimensions for passenger seats, the number of seats on our aircraft would be reduced and our operating costs would increase.

In addition, the TSA imposes security procedures and requirements on U.S. airports and airlines serving U.S. airports, some of which are funded by a security fee imposed on passengers and collected by airlines, which impedes our ability to stimulate demand through low fares. We cannot forecast what additional security and safety requirements may be imposed in the future or the costs or revenue impact that would be associated with complying with such requirements.

Our ability to operate as an airline is dependent on our obtaining and maintaining authorizations issued to us by the DOT and the FAA. The FAA has the authority to issue mandatory orders relating to, among other things, operating aircraft, the grounding of aircraft, maintenance and inspection of aircraft, installation of new safety-related items, and removal and replacement of aircraft parts that have failed or may fail in the future. A decision by the FAA to ground, or require time-consuming inspections of or maintenance on, our aircraft, for any reason, could negatively affect our business, results of operations and financial condition. Federal law requires that air carriers operating scheduled service be continuously "fit, willing and able" to provide the services for which they are licensed. Our "fitness" is monitored by the DOT, which considers managerial competence, operations, finances, and compliance record. In addition, under federal law, we must be a U.S. citizen (as determined under applicable law). Please see "*Business—Foreign Ownership.*" While the DOT has seldom revoked a carrier's certification for lack of fitness, such an occurrence would render it impossible for us to continue operating as an airline. The DOT may also institute investigations or administrative proceedings against airlines for violations of regulations.

International routes are regulated by air transport agreements and related agreements between the United States and foreign governments. Our ability to operate international routes is subject to change because the applicable agreements between the United States and foreign governments may be amended from time to time. Our access to new international markets may be limited by the applicable air transport agreements between the U.S. and foreign governments and our ability to obtain the necessary authority from the U.S. and foreign governments to fly the international routes. In addition, our operations in foreign countries are subject to regulation by foreign governments and our business may be affected by changes in law and future actions taken by such governments, including granting or withdrawal of government approvals and airport slots and restrictions on competitive practices. We are subject to numerous foreign regulations in the countries outside the United States where we currently provide service. If we are not able to comply with this complex regulatory regime, our business could be significantly harmed. Please see "*Business—Government Regulation.*"

***Our business could be materially adversely affected if we lose the services of our key personnel.***

Our success depends to a significant extent upon the efforts and abilities of our senior management team and key financial and operating personnel. In particular, we depend on the services of our senior management team, particularly Jude Bricker, our Chief Executive Officer, and Dave Davis, our President and Chief Financial Officer. Competition for highly qualified personnel is intense, and the loss of any executive officer, senior manager, or other key employee without adequate replacement or the inability to attract new qualified personnel could have a material adverse effect on our business, results of operations and financial condition. We do not maintain key-man life insurance on our management team.

***The requirements of being a public company may strain our resources, divert management's attention and affect our ability to attract and retain qualified board members or executive officers.***

As a public company, we will incur significant legal, accounting and other expenses that we did not incur as a private company, including costs associated with public company reporting requirements and maintaining liability insurance for our directors and officers. We also have incurred and will incur costs associated with the Sarbanes-Oxley Act of 2002, as amended, or the Sarbanes-Oxley Act, the Dodd-Frank Act, related rules implemented or to be implemented by the Securities and Exchange Commission, or the SEC, and the listing rules of the NYSE. The expenses incurred by public companies generally for reporting and corporate governance purposes have been increasing. We expect these rules and regulations to increase our legal and financial compliance costs and to make some activities more time-consuming and costly, although we are currently unable to estimate these costs with any degree of certainty. These laws and regulations could also make it more costly for us to obtain certain types of insurance, including director and officer liability insurance, and we may be forced to accept reduced policy limits and coverage or incur substantially higher costs to obtain the same or similar coverage. These laws and regulations could also make it more difficult for us to attract and retain qualified persons to serve on our board of directors or our board committees or as our executive officers and may divert management's attention. Furthermore, if we are unable to satisfy our obligations as a public company, our common stock could be delisted, and we could be subject to fines, sanctions and other regulatory action and potentially civil litigation.

***Our quarterly results of operations fluctuate due to a number of factors, including seasonality.***

We expect our quarterly results of operations to continue to fluctuate due to a number of factors, including our seasonal operations, competitive responses in key locations or routes, price changes in aircraft fuel and the timing and amount of maintenance expenses. As a result of these and other factors, quarter-to-quarter comparisons of our results of operations and month-to-month comparisons of our key operating statistics may not be reliable indicators of our future performance. Seasonality may cause our quarterly and monthly results to fluctuate since historically our passengers tend to fly more during the winter months and less in the summer and fall months. We cannot assure you that we will find profitable markets in which to operate during the off-peak season. Lower demand for air travel during the fall and other off-peak months could have a material adverse effect on our business, results of operations and financial condition.

***We may not realize any or all of our estimated cost savings, which would have a negative effect on our results of operations.***

As part of our business strategy, we expect to implement certain operational improvements and cost savings initiatives. Any cost savings that we realize from such efforts may differ materially from our estimates. The estimates contained herein are the current estimates of the Company, but they involve risks, uncertainties, assumptions and other factors that may cause actual results, performance or achievements of the Company to be materially different from any future results, performance or achievements expressed or implied by such estimates. In addition, any cost savings that we realize may be offset, in whole or in part, by reductions in revenues, or through increases in other expenses. Any one-time costs incurred to achieve our cost savings going

## [Table of Contents](#)

forward may be more than we expect and, to achieve additional cost savings, we may need to incur additional one-time costs. Our operational improvements and cost savings plans are subject to numerous risks and uncertainties that may change at any time. We cannot assure you that our initiatives will be completed as anticipated or that the benefits we expect will be achieved on a timely basis or at all. The future performance of the Company may differ significantly from the anticipated performance of the Company set forth herein.

### ***We may become involved in litigation that may materially adversely affect us.***

From time to time, we may become involved in various legal proceedings relating to matters incidental to the ordinary course of our business, including commercial, employment, class action, whistleblower, patent, product liability and other litigation and claims, and governmental and other regulatory investigations and proceedings. In particular, in recent years, there has been significant litigation in the United States and abroad involving airline consumer complaints. We have in the past faced, and may face in the future, claims by third parties that we have violated a passenger's rights. Such matters can be time-consuming, divert management's attention and resources, cause us to incur significant expenses or liability and/or require us to change our business practices. Because of the potential risks, expenses and uncertainties of litigation, we may, from time to time, settle disputes, even where we believe that we have meritorious claims or defenses. Because litigation is inherently unpredictable, we cannot assure you that the results of any of these actions will not have a material adverse effect on our business, results of operations and financial condition.

### **Risks Related to this Offering and Ownership of Our Common Stock**

#### ***Our stock price may fluctuate significantly and purchasers of our common stock could incur substantial losses.***

The market price of our common stock could vary significantly as a result of a number of factors, some of which are beyond our control. In the event of a drop in the market price of our common stock, you could lose a substantial part or all of your investment in our common stock. The following factors could affect our stock price:

- our operating and financial performance and prospects;
- quarterly variations in the rate of growth (if any) of our financial indicators, such as net income per share, net income and revenues;
- the public reaction to our press releases, our other public announcements and our filings with the SEC;
- strategic actions by our competitors;
- changes in operating performance and the stock market valuations of other companies;
- announcements related to litigation;
- our failure to meet revenue or earnings estimates made by research analysts or other investors;
- changes in revenue or earnings estimates, or changes in recommendations or withdrawal of research coverage, by equity research analysts;
- speculation in the press or investment community;
- sales of our common stock by us or our stockholders, or the perception that such sales may occur;
- changes in accounting principles, policies, guidance, interpretations, or standards;
- additions or departures of key management personnel;
- actions by our stockholders;

## Table of Contents

- general market conditions;
- domestic and international economic, legal and regulatory factors unrelated to our performance;
- material weakness in our internal control over financial reporting; and
- the realization of any risks described under this “*Risk Factors*” section, or other risks that may materialize in the future.

The stock markets in general have experienced extreme volatility that has often been unrelated to the operating performance of particular companies. These broad market fluctuations may adversely affect the trading price of our common stock. Securities class action litigation has often been instituted against companies following periods of volatility in the overall market and in the market price of a company’s securities. Such litigation, if instituted against us, could result in very substantial costs, divert our management’s attention and resources and harm our business, financial condition, and results of operations.

***We are an “emerging growth company,” and will be able take advantage of reduced disclosure requirements applicable to “emerging growth companies,” which could make our common stock less attractive to investors.***

We are an “emerging growth company,” as defined in the JOBS Act, and, for as long as we continue to be an “emerging growth company,” we intend to take advantage of certain exemptions from various reporting requirements applicable to other public companies but not to “emerging growth companies.” These exemptions include not being required to comply with the auditor attestation requirements of Section 404(b) of the Sarbanes-Oxley Act, reduced disclosure obligations regarding executive compensation in our periodic reports and proxy statements, and exemptions from the requirements of holding a nonbinding advisory vote on executive compensation and stockholder approval of any golden parachute payments not previously approved. We could be an “emerging growth company” until the earliest of (i) the last day of the first fiscal year in which our annual gross revenues exceed \$1.07 billion, (ii) the date that we become a “large accelerated filer” as defined in Rule 12b-2 under the Exchange Act, which would occur if the market value of our common stock that is held by non-affiliates exceeds \$700 million as of the last business day of our most recently completed second fiscal quarter, (iii) the last day of our fiscal year following the fifth anniversary of the date of this offering, and (iv) the date on which we have issued more than \$1 billion in non-convertible debt during the preceding three-year period. We cannot predict if investors will find our common stock less attractive if we choose to rely on these exemptions. If some investors find our common stock less attractive as a result of any choices to reduce future disclosure, there may be a less active trading market for our common stock and our stock price may decline or become more volatile and it may be difficult for us to raise additional capital if and when we need it.

***We will incur significant costs and devote substantial management time as a result of operating as a public company, particularly after we are no longer an “emerging growth company.”***

As a public company, we will continue to incur significant legal, accounting and other expenses. For example, we will be required to comply with the requirements of Section 404(a) of the Sarbanes-Oxley Act and the Dodd-Frank Act, as well as rules and regulations subsequently implemented by the SEC and the NYSE, our stock exchange, including the establishment and maintenance of effective disclosure and financial controls and changes in corporate governance practices. The rules governing management’s assessment of our internal control over financial reporting are complex and require significant documentation, testing and possible remediation. We expect that compliance with these requirements will increase our legal and financial compliance costs and will make some activities more time consuming and costly. In addition, we expect that our management and other personnel will need to divert attention from operational and other business matters to devote substantial time to these public company requirements. In particular, we expect to continue incurring significant expenses and devote substantial management effort toward ensuring compliance with the requirements of the Sarbanes-Oxley Act. In that regard, we may need to hire additional accounting and financial staff with appropriate public company experience and technical accounting knowledge. Furthermore, if we fail to achieve and maintain an effective internal control environment, we could suffer material misstatements in our consolidated financial statements and fail to meeting our reporting obligations, which would likely cause investors to lose confidence in



## Table of Contents

our reported financial information. Additionally, ineffective internal control over financial reporting could expose us to increased risk of fraud or misuse of corporate assets and subject us to potential delisting from the NYSE, regulatory investigations, civil or criminal sanctions and litigation, any of which would have a material adverse effect on our business, results of operations and financial condition.

However, for as long as we remain an “emerging growth company” as defined in the JOBS Act, we intend to take advantage of certain exemptions from various reporting requirements that are applicable to other public companies that are not “emerging growth companies” including, but not limited to, not being required to comply with the auditor attestation requirements of Section 404(b) of the Sarbanes-Oxley Act, reduced disclosure obligations regarding executive compensation in our periodic reports and proxy statements, and exemptions from the requirements of holding a nonbinding advisory vote on executive compensation and stockholder approval of any golden parachute payments not previously approved.

Under the JOBS Act, “emerging growth companies” can delay adopting new or revised accounting standards until such time as those standards apply to private companies.

After we are no longer an “emerging growth company,” we expect to incur additional management time and cost to comply with the more stringent reporting requirements applicable to companies that are deemed accelerated filers or large accelerated filers, including complying with the auditor attestation requirements of Section 404 of the Sarbanes-Oxley Act.

We cannot predict or estimate the amount of additional costs we may incur as a result of becoming a public company or the timing of such costs.

### ***We are continuing to improve our internal control over financial reporting.***

Our independent registered public accounting firm is not required to audit the effectiveness of our internal control over financial reporting until after we are no longer an “emerging growth company,” as defined in the JOBS Act, which at the latest would be the end of the fiscal year following the fifth anniversary of this offering. At such time, our internal control over financial reporting may be insufficiently documented, designed or operating, which may cause our independent registered public accounting firm to issue a report that is adverse.

### ***Our certificate of incorporation and bylaws include provisions limiting ownership and voting by non-U.S. citizens.***

To comply with restrictions imposed by federal law on foreign ownership and control of U.S. airlines, our certificate of incorporation and bylaws will restrict ownership and control of shares of our common stock by non-U.S. citizens. The restrictions imposed by federal law currently require that we be owned and controlled by U.S. citizens, that no more than 25.0% of our voting stock be owned or controlled, directly or indirectly, by persons or entities who are not U.S. citizens, as defined in 49 U.S.C. § 40102(a)(15), that no more than 49.0% of our stock be owned or controlled, directly or indirectly, by persons or entities who are not U.S. citizens and are from countries that have entered into “open skies” air transport agreements with the United States, that our president and at least two-thirds of the members of our board of directors and other managing officers be U.S. citizens and that we be under the actual control of U.S. citizens. Our certificate of incorporation and bylaws will provide that the failure of non-U.S. citizens to register their shares on a separate stock record, which we refer to as the “foreign stock record,” would result in a loss of their voting rights in the event and to the extent that the aggregate foreign ownership of the outstanding common stock exceeds the foreign ownership restrictions imposed by federal law. Our bylaws will further provide that no shares of our common stock will be registered on the foreign stock record if the amount so registered would exceed the foreign ownership restrictions imposed by federal law. If it is determined that the amount registered in the foreign stock record exceeds the foreign ownership restrictions imposed by federal law, shares will be removed from the foreign stock record, resulting in the loss of voting rights, in reverse chronological order based on the date of registration therein, until the number of shares registered therein does not exceed the foreign ownership restrictions imposed by federal law.



## Table of Contents

In addition, only U.S. citizens may purchase shares in this offering. By participating in this offering, you will be deemed to represent that you are a citizen of the United States, as defined in 49 U.S.C. § 40102(a)(15). The restrictions on ownership and control of shares of our common stock could materially limit your ability to resell any shares you purchase in this offering and could adversely impact the price that investors might be willing to pay in the future for shares of our common stock.

***We continue to be controlled by the Apollo Stockholder, and Apollo's interests may conflict with our interests and the interests of other stockholders.***

Following this offering, the Apollo Stockholder will beneficially own approximately % of the voting power of our outstanding common equity (or approximately % if the underwriters exercise their option to purchase additional shares in full). As a result, the Apollo Stockholder will have the power to elect a majority of our directors. Therefore, individuals affiliated with Apollo will have effective control over the outcome of votes on all matters requiring approval by our stockholders, including entering into significant corporate transactions such as mergers, tender offers, and the sale of all or substantially all of our assets and issuance of additional debt or equity. The interests of Apollo and its affiliates, including the Apollo Funds and the Apollo Stockholder, could conflict with or differ from our interests or the interests of our other stockholders. For example, the concentration of ownership held by the Apollo Stockholder could delay, defer, or prevent a change in control of our company or impede a merger, takeover, or other business combination which may otherwise be favorable for us. Additionally, Apollo and its affiliates are in the business of making investments in companies and may, from time to time, acquire and hold interests in or provide advice to businesses that compete directly or indirectly with us, or are suppliers or customers of ours. Apollo and its affiliates may also pursue acquisition opportunities that may be complementary to our business, and as a result, those acquisition opportunities may not be available to us. Any such investment may increase the potential for the conflicts of interest discussed in this risk factor. So long as the Apollo Stockholder continues to directly or indirectly own a significant amount of our equity, even if such amount is less than 50%, the Apollo Stockholder will continue to be able to substantially influence or effectively control our ability to enter into corporate transactions. In addition, we have an executive committee that serves at the discretion of our Board and is composed of two members nominated by the Apollo Stockholder and our CEO, who are authorized to take actions (subject to certain exceptions) that it reasonably determines are appropriate. See “*Management—Board Committees—Executive Committee*” for a further discussion.

***We are a “controlled company” within the meaning of the NYSE rules and, as a result, qualify for and intend to rely on exemptions from certain corporate governance requirements.***

Following this offering, the Apollo Stockholder will continue to control a majority of the voting power of our outstanding voting stock and, as a result, we will be a controlled company within the meaning of the NYSE corporate governance standards. Under the NYSE rules, a company of which more than 50% of the voting power is held by another person or group of persons acting together is a controlled company and may elect not to comply with certain corporate governance requirements, including the requirements that:

- a majority of the board of directors consist of independent directors;
- the nominating and corporate governance committee be composed entirely of independent directors with a written charter addressing the committee's purpose and responsibilities;
- the compensation committee be composed entirely of independent directors with a written charter addressing the committee's purpose and responsibilities; and
- there be an annual performance evaluation of the nominating and corporate governance and compensation committees.

We intend to utilize these exemptions as long as we remain a controlled company. Accordingly, you may not have the same protections afforded to stockholders of companies that are subject to all of the corporate governance requirements of the NYSE.

## [Table of Contents](#)

***Our organizational documents may impede or discourage a takeover, which could deprive our investors of the opportunity to receive a premium on their shares.***

Provisions of our certificate of incorporation and bylaws may make it more difficult for, or prevent a third party from, acquiring control of us without the approval of our board of directors. These provisions include:

- providing that our board of directors will be divided into three classes, with each class of directors serving staggered three-year terms;
- prohibiting cumulative voting in the election of directors;
- providing for the removal of directors only for cause and only upon the affirmative vote of the holders of at least 66 2/3% in voting power of all the then-outstanding shares of stock of the Company entitled to vote thereon, voting together as a single class, if less than 50.1% of the voting power of our outstanding common stock is beneficially owned by Apollo and its affiliates, including the Apollo Stockholder;
- empowering only the board to fill any vacancy on our board of directors (other than in respect of an Apollo Director (as defined below)), whether such vacancy occurs as a result of an increase in the number of directors or otherwise;
- authorizing the issuance of “blank check” preferred stock without any need for action by stockholders;
- prohibiting stockholders from acting by written consent if less than 50.1% of the voting power of our outstanding common stock is beneficially owned by Apollo and its affiliates, including the Apollo Stockholder;
- to the extent permitted by law, prohibiting stockholders from calling a special meeting of stockholders if less than 50.1% of the voting power of our outstanding common stock is beneficially owned by Apollo and its affiliates, including the Apollo Stockholder; and
- establishing advance notice requirements for nominations for election to our board of directors or for proposing matters that can be acted on by stockholders at stockholder meetings.

Additionally, our certificate of incorporation provides that we are not governed by Section 203 of the DGCL, which, in the absence of such provisions, would have imposed additional requirements regarding mergers and other business combinations. However, our certificate of incorporation will include a provision that restricts us from engaging in any business combination with an interested stockholder for three years following the date that person becomes an interested stockholder, but such restrictions shall not apply to any business combination between Apollo and any affiliate thereof or their direct and indirect transferees, on the one hand, and us, on the other.

Any issuance by us of preferred stock could delay or prevent a change in control of us. Our board of directors will have the authority to cause us to issue, without any further vote or action by the stockholders, shares of preferred stock, par value \$0.01 per share, in one or more series, to designate the number of shares constituting any series, and to fix the rights, preferences, privileges, and restrictions thereof, including dividend rights, voting rights, rights and terms of redemption, redemption price or prices, and liquidation preferences of such series. The issuance of shares of our preferred stock may have the effect of delaying, deferring, or preventing a change in control without further action by the stockholders, even where stockholders are offered a premium for their shares.

In addition, as long as the Apollo Stockholder beneficially owns a majority of the voting power of our outstanding common stock, the Apollo Stockholder will be able to control all matters requiring stockholder approval, including the election of directors, amendment of our certificate of incorporation and certain corporate transactions. Together, these certificate of incorporation, bylaw and statutory provisions could make the removal of management more difficult and may discourage transactions that otherwise could involve payment of a premium over prevailing market prices for our common stock. Furthermore, the existence of the foregoing provisions, as well as the significant common stock beneficially owned by the Apollo Stockholder and its right to

## [Table of Contents](#)

nominate a specified number of directors in certain circumstances, could limit the price that investors might be willing to pay in the future for shares of our common stock. They could also deter potential acquirers of us, thereby reducing the likelihood that you could receive a premium for your common stock in an acquisition. For a further discussion of these and other such anti-takeover provisions, see “*Description of Capital Stock—Certain Corporate Anti-takeover Provisions.*”

***Our certificate of incorporation will provide that the Court of Chancery of the State of Delaware will be the sole and exclusive forum for substantially all disputes between us and our stockholders, which could limit our stockholders’ ability to obtain a favorable judicial forum for disputes with us or our directors, officers or employees.***

Our certificate of incorporation will provide that, unless we consent in writing to the selection of an alternative forum, the Court of Chancery of the State of Delaware is the sole and exclusive forum for (i) any derivative action or proceeding brought on our behalf, (ii) any action asserting a claim of breach of a fiduciary duty owed by any of our directors, officers, employees or agents to us or our stockholders, (iii) any action asserting a claim arising pursuant to any provision of the DGCL or of our certificate of incorporation or our bylaws, or (iv) any action asserting a claim related to or involving the Company that is governed by the internal affairs doctrine. However, the exclusive forum provision will not apply to suits brought to enforce any liability or duty created by the Securities Act of 1933, as amended, or the Securities Act, the Securities Exchange Act of 1934, as amended, or the Exchange Act, or any other claim for which the federal courts have exclusive jurisdiction.

Any person or entity purchasing or otherwise acquiring any interest in shares of our capital stock will be deemed to have notice of and, to the fullest extent permitted by law, to have consented to the provisions of our certificate of incorporation described above. The choice of forum provision may limit a stockholder’s ability to bring a claim in a judicial forum that it finds favorable for disputes with us or our directors, officers, or other employees, which may discourage such lawsuits against us and our directors, officers and other employees. However, the enforceability of similar forum provisions in other companies’ certificates of incorporation has been challenged in legal proceedings. If a court were to find the choice of forum provision contained in our certificate of incorporation to be inapplicable or unenforceable in an action, we may incur additional costs associated with resolving such action in other jurisdictions, which could materially adversely affect our business, financial condition and results of operations.

***Our certificate of incorporation will contain a provision renouncing our interest and expectancy in certain corporate opportunities.***

Under our certificate of incorporation, none of Apollo, its affiliated funds, the portfolio companies owned by such funds, the Apollo Stockholder, any other affiliates of Apollo or any of their respective officers, directors, agents, stockholders, members or partners will have any duty to refrain from engaging, directly or indirectly, in the same business activities, similar business activities, or lines of business in which we operate. In addition, our certificate of incorporation provides that, to the fullest extent permitted by law, no officer or director of ours who is also an officer, director, employee, managing director or other affiliate of Apollo or its affiliates will be liable to us or our stockholders for breach of any fiduciary duty by reason of the fact that any such individual directs a corporate opportunity to Apollo or its affiliates, instead of us, or does not communicate information regarding a corporate opportunity to us that the officer, director, employee, managing director, or other affiliate has directed to Apollo or its affiliates. For instance, a director of our company who also serves as a director, officer, or employee of Apollo or any of its portfolio companies, funds or other affiliates may pursue certain acquisitions or other opportunities that may be complementary to our business and, as a result, such acquisition or other opportunities may not be available to us. Upon consummation of this offering, our board of directors will consist of ten members, of whom will be Apollo Directors. These potential conflicts of interest could have a material adverse effect on our business, financial condition, results of operations, or prospects if attractive corporate opportunities are allocated by Apollo to itself or its affiliated funds, the portfolio companies owned by such funds, the Apollo Stockholder or any other affiliates of Apollo instead of to us. A description of our

## [Table of Contents](#)

obligations related to corporate opportunities under our certificate of incorporation are more fully described in “*Description of Capital Stock—Corporate Opportunity*.”

***We are a holding company and rely on dividends, distributions, and other payments, advances, and transfers of funds from our subsidiaries to meet our obligations.***

We are a holding company that does not conduct any business operations of our own. As a result, we are largely dependent upon cash dividends and distributions and other transfers, including for payments in respect of our indebtedness, from our subsidiaries to meet our obligations. The agreements governing the indebtedness of our subsidiaries impose restrictions on our subsidiaries’ ability to pay dividends or other distributions to us. See “*Management’s Discussion and Analysis of Financial Condition and Results of Operations—Liquidity and Capital Resources*.” Each of our subsidiaries is a distinct legal entity, and under certain circumstances legal and contractual restrictions may limit our ability to obtain cash from them and we may be limited in our ability to cause any future joint ventures to distribute their earnings to us. The deterioration of the earnings from, or other available assets of, our subsidiaries for any reason could also limit or impair their ability to pay dividends or other distributions to us.

***Investors in this offering will experience immediate and substantial dilution.***

Based on our pro forma as adjusted net tangible book value per share as of December 31, 2019 and an initial public offering price of \$      per share, we expect that purchasers of our common stock in this offering will experience an immediate and substantial dilution of \$      per share, representing the difference between our pro forma as adjusted net tangible book value per share and the initial public offering price. This dilution is due in large part to earlier investors having paid substantially less than the initial public offering price when they purchased their shares. See “*Dilution*.”

***Our future earnings and earnings per share, as reported under GAAP, could be adversely impacted by the warrants granted to Amazon. If Amazon exercises its right to acquire shares of our common stock pursuant to the 2019 Warrants, this will dilute the ownership interests of our then-existing stockholders and could adversely affect the market price of our common stock.***

The warrants granted to Amazon increase the number of diluted shares reported, which has an effect on our fully diluted earnings per share. Further, the 2019 Warrants are presented as liabilities in our consolidated balance sheet and are subject to fair value measurement adjustments during the periods that they are outstanding. Accordingly, future fluctuations in the fair value of the 2019 Warrants could have a material adverse effect on our results of operations. In addition, the majority of the 2019 Warrants will vest incrementally based on aggregate global payments by Amazon to the Company or its affiliates pursuant to the ATSA, or in certain circumstances, including upon a change of control (as defined in the 2019 Warrant) or certain transfers of 30% or more of the voting power in the Company to a new person or group (other than this offering or any follow-on equity offering by the Company or the Apollo Stockholder pursuant to an effective registration statement so long as no person or group (within the meaning of the Exchange Act) acquires more than 50% of the voting power of the Company in such offering), immediately. If additional 2019 Warrants vest and Amazon exercises its right to acquire shares of our common stock pursuant to the 2019 Warrants, which exercise (just like an investment in our company generally) is subject to limitations imposed by federal law on foreign ownership and control of U.S. airlines (see “*Description of Capital Stock—Limited Ownership and Voting by Foreign Owners*”), it will dilute the ownership interests of our then-existing stockholders and reduce our earnings per share. In addition, to the extent the common stock issued upon exercise of the 2019 Warrants is held by non-U.S. citizens, it will further limit the amount of our common stock that may be owned or controlled by other non-U.S. citizens. Furthermore, any sales in the public market of any common stock issuable upon the exercise of the 2019 Warrants could adversely affect prevailing market prices of our common stock. So long as Amazon holds the 2019 Warrants or any shares of common stock issued upon exercise of the 2019 Warrants and the ATSA remains in effect, Amazon will also have the right to nominate a member or an observer to our board of directors.

## [Table of Contents](#)

***You may be diluted by the future issuance of additional common stock or convertible securities in connection with our incentive plans, acquisitions or otherwise, which could adversely affect our stock price.***

After the completion of this offering, we will have \_\_\_\_\_ shares of common stock authorized but unissued. Our certificate of incorporation will authorize us to issue these shares of common stock and options, rights, warrants and appreciation rights relating to common stock for the consideration and on the terms and conditions established by our board of directors in its sole discretion, whether in connection with acquisitions or otherwise. At the closing of this offering, we will have approximately \_\_\_\_\_ options outstanding, which are exercisable into approximately \_\_\_\_\_ shares of common stock, and the 2019 Warrants outstanding, which are exercisable for approximately \_\_\_\_\_ shares of common stock, subject to limitations imposed by federal law on foreign ownership and control of U.S. airlines and vesting requirements. See “*Description of Capital Stock—Limited Ownership and Voting by Foreign Owners.*” Of the \_\_\_\_\_ 2019 Warrants, approximately \_\_\_\_\_ % have vested and the remainder will vest incrementally based on aggregate global payments by Amazon to the Company or its affiliates pursuant to the ATSA. We have reserved approximately \_\_\_\_\_ shares for future grant under our Omnibus Equity Plan. See “*Executive Compensation—Equity Compensation Plans—2020 Omnibus Incentive Plan.*” Any common stock that we issue, including under our Omnibus Equity Plan or other equity incentive plans that we may adopt in the future, as well as under outstanding options or warrants would dilute the percentage ownership held by the investors who purchase common stock in this offering.

From time to time in the future, we may also issue additional shares of our common stock or securities convertible into common stock pursuant to a variety of transactions, including acquisitions. Our issuance of additional shares of our common stock or securities convertible into our common stock would dilute your ownership of us and the sale of a significant amount of such shares in the public market could adversely affect prevailing market prices of our common stock.

***Our ABL Facility contains restrictions that limit our flexibility.***

Our ABL Facility contains, and any future indebtedness of ours could also contain, a number of covenants that impose significant operating and financial restrictions on us, including restrictions on our and our subsidiaries’ ability to, among other things:

- incur additional debt, guarantee indebtedness, or issue certain preferred equity interests;
- pay dividends on or make distributions in respect of, or repurchase or redeem, our capital stock, or make other restricted payments;
- prepay, redeem, or repurchase certain debt;
- make loans or certain investments;
- sell certain assets;
- create liens on certain assets;
- consolidate, merge, sell, or otherwise dispose of all or substantially all of our assets;
- enter into certain transactions with our affiliates;
- alter the businesses we conduct;
- enter into agreements restricting our subsidiaries’ ability to pay dividends; and
- designate our subsidiaries as unrestricted subsidiaries.

As a result of these covenants, we will be limited in the manner in which we conduct our business, and we may be unable to engage in favorable business activities or finance future operations or capital needs. These restrictive covenants may limit our ability to engage in activities that may be in our long-term best interest. The failure to comply with those covenants could result in an event of default which, if not cured or waived, could result in the acceleration of substantially all of our indebtedness.

## Table of Contents

***Future sales of our common stock in the public market, or the perception in the public market that such sales may occur, could reduce our stock price.***

After the completion of this offering and the use of proceeds therefrom, we will have \_\_\_\_\_ shares of common stock outstanding, warrants to purchase \_\_\_\_\_ shares of common stock outstanding and options to purchase \_\_\_\_\_ shares of common stock outstanding. The number of outstanding shares of common stock includes \_\_\_\_\_ shares beneficially owned by the Apollo Stockholder and certain of our employees, which are “restricted securities,” as defined under Rule 144 under the Securities Act, and eligible for sale in the public market subject to the requirements of Rule 144. We, the selling stockholder, each of our officers and directors and all of our other existing stockholders have agreed that (subject to certain exceptions), for a period of 180 days after the date of this prospectus, we and they will not, without the prior written consent of certain underwriters, dispose of any shares of common stock or any securities convertible into or exchangeable for our common stock, subject to certain exceptions. See “*Underwriting.*” Following the expiration of the applicable lock-up period, all of the issued and outstanding shares of our common stock will be eligible for future sale, subject to the applicable volume, manner of sale, holding periods, and other limitations of Rule 144. The underwriters may, in their sole discretion, release all or any portion of the shares subject to lock-up agreements at any time and for any reason. In addition, the Apollo Stockholder, certain of our existing stockholders and Amazon have certain rights to require us to register the sale of common stock held by them including in connection with underwritten offerings. Sales of significant amounts of stock in the public market upon expiration of lock-up agreements, the perception that such sales may occur, or early release of any lock-up agreements, could adversely affect prevailing market prices of our common stock or make it more difficult for you to sell your shares of common stock at a time and price that you deem appropriate. See “*Shares Eligible for Future Sale*” for a discussion of the shares of common stock that may be sold into the public market in the future.

***There has been no prior public market for our common stock and there can be no assurances that a viable public market for our common stock will develop or be sustained.***

Prior to this offering, our common stock was not traded on any market. An active, liquid and orderly trading market for our common stock may not develop or be maintained after this offering. Active, liquid and orderly trading markets usually result in less price volatility and more efficiency in carrying out investors’ purchase and sale orders. We cannot predict the extent to which investor interest in our common stock will lead to the development of an active trading market on the NYSE or otherwise or how liquid that market might become. The initial public offering price for the common stock will be determined by negotiations between us, the selling stockholder and the representatives of the underwriters and may not be indicative of prices that will prevail in the open market following this offering. See “*Underwriting.*” If an active public market for our common stock does not develop, or is not sustained, it may be difficult for you to sell your shares at a price that is attractive to you or at all.

***The initial public offering price of our common stock may not be indicative of the market price of our common stock after this offering.***

The initial public offering price was determined by negotiations between us, the selling stockholder and representatives of the underwriters, based on numerous factors which we discuss in “*Underwriting.*” and may not be indicative of the market price of our common stock after this offering. If you purchase our common stock, you may not be able to resell those shares at or above the initial public offering price.

***We do not anticipate paying dividends on our common stock in the foreseeable future.***

We do not anticipate paying any dividends in the foreseeable future on our common stock. We intend to retain all future earnings for the operation and expansion of our business and the repayment of outstanding debt. Our ABL Facility contains, and any future indebtedness likely will contain, restrictive covenants that impose significant operating and financial restrictions on us, including restrictions on our ability to pay dividends and

---

## [Table of Contents](#)

make other restricted payments. As a result, capital appreciation, if any, of our common stock may be your major source of gain for the foreseeable future. While we may change this policy at some point in the future, we cannot assure you that we will make such a change. See “*Dividend Policy*.”

***If securities or industry analysts do not publish research or reports about our business or publish negative reports, our stock price could decline.***

The trading market for our common stock will be influenced by the research and reports that industry or securities analysts publish about us or our business. If one or more of these analysts ceases coverage of our company or fails to publish reports on us regularly, we could lose visibility in the financial markets, which in turn could cause our stock price or trading volume to decline. Moreover, if one or more of the analysts who cover our company downgrades our common stock or if our operating results do not meet their expectations, our stock price could decline.

***We may issue preferred securities, the terms of which could adversely affect the voting power or value of our common stock.***

Our certificate of incorporation will authorize us to issue, without the approval of our stockholders, one or more classes or series of preferred securities having such designations, preferences, limitations, and relative rights, including preferences over our common stock respecting dividends and distributions, as our board of directors may determine. The terms of one or more classes or series of preferred securities could adversely impact the voting power or value of our common stock. For example, we might grant holders of preferred securities the right to elect some number of our directors in all events or on the happening of specified events or the right to veto specified transactions. Similarly, the repurchase or redemption rights or liquidation preferences we might assign to holders of preferred securities could affect the residual value of the common stock.

## CAUTIONARY NOTE REGARDING FORWARD-LOOKING STATEMENTS

This prospectus contains forward-looking statements, which involve risks and uncertainties. These forward-looking statements are generally identified by the use of forward-looking terminology, including the terms “anticipate,” “believe,” “continue,” “could,” “estimate,” “expect,” “intend,” “likely,” “may,” “plan,” “possible,” “potential,” “predict,” “project,” “should,” “target,” “will,” “would” and, in each case, their negative or other various or comparable terminology. All statements other than statements of historical facts contained in this prospectus, including statements regarding our strategy, future operations, future financial position, future revenue, projected costs, prospects, plans, objectives of management, and expected market growth are forward-looking statements. The forward-looking statements are contained principally in the sections entitled “*Prospectus Summary*,” “*Risk Factors*,” “*Use of Proceeds*,” “*Management’s Discussion and Analysis of Financial Condition and Results of Operations*,” and “*Business*” and include, among other things, statements relating to:

- our strategy, outlook and growth prospects;
- our operational and financial targets and dividend policy;
- general economic trends and trends in the industry and markets; and
- the competitive environment in which we operate.

These statements involve known and unknown risks, uncertainties and other important factors that may cause our actual results, performance, or achievements to be materially different from any future results, performance, or achievements expressed or implied by the forward-looking statements. Important factors that could cause our results to vary from expectations include, but are not limited to:

- the impact of worldwide economic conditions;
- changes in our fuel cost;
- threatened or actual terrorist attacks, global instability and potential U.S. military actions or activities;
- the competitive environment in our industry;
- factors beyond our control, including air traffic congestion, weather, security measures, travel-related taxes and outbreak of disease;
- our presence in international markets;
- insurance costs;
- changes in restrictions on, or increased taxes applicable to charges for, ancillary products and services;
- air travel substitutes;
- our ability to implement our business strategy successfully;
- our ability to keep costs low;
- our reliance on the Minneapolis/St. Paul market;
- our reputation and business being adversely affected in the event of an emergency, accident or similar public incident involving our aircraft or personnel;
- our reliance on third-party providers and other commercial partners to perform functions integral to our operations.
- operational disruptions;
- our ability to grow or maintain our unit revenues or maintain our ancillary revenues;
- increased labor costs, union disputes, employee strikes and other labor-related disruptions;



## Table of Contents

- governmental regulation;
- our inability to maintain an optimal daily aircraft utilization rate;
- our ability to attract and retain qualified personnel;
- our inability to expand or operate reliably and efficiently out of airports where we maintain a large presence;
- environmental and noise laws and regulations;
- negative publicity regarding our customer service;
- our liquidity and dependence on cash balances and operating cash flows;
- our ability to maintain our liquidity in the event one or more of our credit card processors were to impose holdback restrictions;
- our ability to obtain financing or access capital markets;
- aircraft-related fixed obligations that could impair our liquidity;
- our maintenance obligations;
- our sole-source supplier for our aircraft and engines;
- loss of key personnel; and
- other risk factors included under “*Risk Factors*” in this prospectus.

These forward-looking statements reflect our views with respect to future events as of the date of this prospectus and are based on assumptions and subject to risks and uncertainties. Given these uncertainties, you should not place undue reliance on these forward-looking statements. These forward-looking statements represent our estimates and assumptions only as of the date of this prospectus and, except as required by law, we undertake no obligation to update or review publicly any forward-looking statements, whether as a result of new information, future events or otherwise after the date of this prospectus. We anticipate that subsequent events and developments will cause our views to change. You should read this prospectus and the documents filed as exhibits to the registration statement, of which this prospectus is a part, completely and with the understanding that our actual future results may be materially different from what we expect. Our forward-looking statements do not reflect the potential impact of any future acquisitions, merger, dispositions, joint ventures, or investments we may undertake. We qualify all of our forward-looking statements by these cautionary statements.

## USE OF PROCEEDS

We expect to receive approximately \$       million of net proceeds (based upon the assumed initial public offering price of \$       per share, the midpoint of the range set forth on the cover page of this prospectus) from the sale of the common stock offered by us, after deducting underwriting discounts and commissions and estimated offering expenses payable by us. Each \$1.00 increase (decrease) in the public offering would increase (decrease) our net proceeds by approximately \$       million.

We currently expect to use approximately \$       million of the net proceeds to us from this offering to pay fees and expenses in connection with this offering, which include legal and accounting fees, SEC and FINRA registration fees, printing expenses, and other similar fees and expenses. We intend to use any remaining proceeds for general corporate purposes. While we currently have no specific plan for the use of the remaining net proceeds to us of this offering, we anticipate using a significant portion of these proceeds to implement our growth strategies and generate funds for working capital. Our management team will retain broad discretion to allocate the net proceeds of this offering. The precise amounts and timing of our use of any remaining net proceeds will depend upon market conditions, among other factors.

We will not receive any of the proceeds from the sale of shares of common stock offered by the selling stockholder.

## DIVIDEND POLICY

We currently do not intend to pay cash dividends on our common stock in the foreseeable future. However, we may, in the future, decide to pay dividends on our common stock. Any declaration and payment of cash dividends in the future, if any, will be at the discretion of our board of directors and will depend upon such factors as earnings levels, cash flows, capital requirements, levels of indebtedness, restrictions imposed by applicable law, our overall financial condition, restrictions in our debt agreements and any other factors deemed relevant by our board of directors.

As a holding company, our ability to pay dividends depends on our receipt of cash dividends from our operating subsidiaries. Our ability to pay dividends will therefore be restricted as a result of restrictions on their ability to pay dividends to us under our ABL Facility and under other current and future indebtedness that we or they may incur. See “*Risk Factors—Risks Related to this Offering and Ownership of Our Common Stock*” and “*Management’s Discussion and Analysis of Financial Condition and Results of Operations—Liquidity and Capital Resources.*”

## CAPITALIZATION

The following table sets forth our cash and cash equivalents and our capitalization as of December 31, 2019 on:

- an actual basis;
- a pro forma basis to give effect to the Reorganization Transactions; and
- a pro forma as adjusted basis to give further effect to this offering and the application of the net proceeds to us of this offering as described under “*Use of Proceeds*.”

You should read this table together with the information included elsewhere in this prospectus, including “*Prospectus Summary—Summary Consolidated Financial and Operating Information*,” “*Selected Historical Consolidated Financial Data*,” “*Management’s Discussion and Analysis of Financial Condition and Results of Operations*,” and our audited consolidated financial statements and the related notes thereto.

	As of December 31, 2019		
	Actual	Pro forma	Pro forma as adjusted
	(in thousands, except share data)		
Cash and cash equivalents	\$	\$	\$
Total debt	\$	\$	\$
Stockholders’ Equity:			
SCA common stock—no par value, 5,000,000 shares authorized; 360,009 shares issued and outstanding (actual); no shares issued and outstanding (pro forma and pro forma as adjusted)		—	—
Common stock—\$0.01 par value; no shares authorized, no shares issued and outstanding (actual); shares authorized, shares issued and outstanding (pro forma); shares authorized, shares issued and outstanding (pro forma as adjusted) (1)	—		
Preferred stock—\$0.01 par value; no shares authorized, no shares issued and outstanding (actual); shares authorized, no shares issued and outstanding (pro forma and pro forma as adjusted)	—	—	—
Loans to SCA common stockholders		—	—
Additional paid-in capital			
Retained earnings			
Total stockholders’ equity			
<b>Total capitalization</b>	<b>\$</b>	<b>\$</b>	<b>\$</b>

(1) Following this offering, 2019 Warrants to purchase an aggregate of \_\_\_\_\_ shares of common stock, approximately \_\_\_\_\_ % of which have vested, will remain outstanding. As is the case for investment in our company generally, the exercise of the 2019 Warrants is limited by restrictions imposed by federal law on foreign ownership and control of U.S. airlines. See “*Description of Capital Stock—Limited Ownership and Voting by Foreign Owners*.”

## DILUTION

Purchasers of the common stock in this offering will experience immediate and substantial dilution to the extent of the difference between the initial public offering price per share of our common stock and the pro forma as adjusted net tangible book value per share of our common stock after this offering.

Our pro forma net tangible book value as of December 31, 2019 was \$ \_\_\_\_\_, or \$ \_\_\_\_\_ per share of our common stock. Pro forma net tangible book value per share represents the amount of our total tangible assets (total assets less goodwill and deferred offering costs) less total liabilities divided by the number of shares of common stock issued and outstanding as of December 31, 2019, after giving effect to the Reorganization Transactions.

Our pro forma as adjusted net tangible book value as of December 31, 2019 was \$ \_\_\_\_\_, or \$ \_\_\_\_\_ per share of our common stock. Pro forma as adjusted net tangible book value per share represents our pro forma net tangible book value after giving effect to the sale of \_\_\_\_\_ shares of common stock by us in this offering at the assumed initial public offering price of \$ \_\_\_\_\_ per share (the midpoint of the range set forth on the cover page of this prospectus) and the application of the net proceeds to us from this offering.

The following table illustrates the dilution per share of our common stock:

Assumed initial public offering price per share	\$ _____
Pro forma net tangible book value per share as of December 31, 2019	_____
Increase in pro forma net tangible book value per share attributable to new investors purchasing shares in this offering	_____
Pro forma as adjusted net tangible book value per share after this offering	_____
Dilution per share to new investors purchasing shares in this offering	\$ _____

Dilution per share to new investors purchasing shares in this offering is determined by subtracting pro forma as adjusted net tangible book value per share after this offering from the initial public offering price per share of common stock.

The dilution information discussed above is illustrative only and may change based on the actual initial public offering price and other terms of this offering. A \$1.00 increase (decrease) in the assumed initial public offering price of \$ \_\_\_\_\_ per share of common stock, the midpoint of the range set forth on the cover page of this prospectus, would increase (decrease) our pro forma as adjusted net tangible book value per share after this offering by \$ \_\_\_\_\_ per share and increase (decrease) the dilution to new investors by \$ \_\_\_\_\_ per share, in each case assuming the number of shares of common stock offered by us, as set forth on the cover page of this prospectus, remains the same, and after deducting estimated underwriting discounts and commissions. Similarly, each increase or decrease of 1,000,000 shares in the number of shares of common stock offered by us would increase (decrease) our pro forma as adjusted net tangible book value by approximately \$ \_\_\_\_\_ per share and decrease (increase) the dilution to new investors by approximately \$ \_\_\_\_\_ per share, in each case assuming the assumed initial public offering price of \$ \_\_\_\_\_ per share of common stock remains the same, and after deducting estimated underwriting discounts and commissions.

The following table summarizes, as of December 31, 2019, on a pro forma as adjusted basis as described above, the total number of shares of common stock owned by existing stockholders and to be owned by new

## Table of Contents

investors, the total consideration paid, and the average price per share paid by our existing stockholders and to be paid by new investors in this offering at the assumed initial public offering price of \$ per share, calculated before deduction of estimated underwriting discounts and commissions and estimated offering expenses payable by us.

	Shares Purchased		Total Consideration		Average Price per Share
	Number	Percent	Amount	Percent	
Existing stockholders		%	\$	%	\$
Investors in the offering		%		%	
Total		100%	\$	100%	\$

A \$1.00 increase (decrease) in the assumed initial public offering price would increase (decrease) total consideration paid by new investors, total consideration paid by all stockholders and average price per share paid by new investors by \$ , \$ and \$ per share, respectively.

If the underwriters were to fully exercise their option to purchase additional shares of our common stock, the percentage of common stock held by existing investors would be %, and the percentage of shares of common stock held by new investors would be %.

The foregoing tables and calculations, except as otherwise indicated:

- give effect to the Reorganization Transactions;
- assume an initial public offering price of \$ per share of common stock, the midpoint of the range set forth on the cover of this prospectus;
- assume no exercise of the underwriters' option to purchase additional shares of common stock from the selling stockholder;
- assume no exercise of the 2019 Warrants to purchase an aggregate of shares of common stock, approximately % of which have vested. As is the case for investment in our company generally, the exercise of the 2019 Warrants is limited by restrictions imposed by federal law on foreign ownership and control of U.S. airlines. See "*Description of Capital Stock—Limited Ownership and Voting by Foreign Owners*";
- do not reflect an additional shares of our common stock reserved for future grant under the Omnibus Equity Plan. See "*Executive Compensation—Equity Compensation Plans—2020 Omnibus Incentive Plan*"; and
- do not reflect shares of common stock that may be issued upon the exercise of stock options outstanding as of the consummation of this offering under the SCA Acquisition Equity Plan. The following table sets forth the outstanding stock options under the SCA Acquisition Equity Plan as of December 31, 2019 (after giving effect to the Reorganization Transactions):

	Number of Options(1)	Weighted-Average Exercise Price Per Share
Vested stock options (time-based vesting)		\$
Unvested stock options (time-based vesting)		\$
Unvested stock options (performance-based vesting)		\$

(1) Upon a holder's exercise of one option, we will issue to the holder one share of common stock.

---

[Table of Contents](#)

We may choose to raise additional capital due to market conditions or strategic considerations even if we believe we have sufficient funds for our current or future operating plans. To the extent that additional capital is raised through the sale of equity or convertible debt securities, the issuance of such securities could result in further dilution to our stockholders. To the extent that any outstanding options or warrants to purchase our common stock are exercised, or new awards are granted under our equity compensation plans, there will be further dilution to investors participating in this offering.

## SELECTED HISTORICAL CONSOLIDATED FINANCIAL DATA

The following tables present our selected consolidated financial data for the periods indicated. We have derived our selected historical consolidated statement of operations data for the year ended December 31, 2019 and for the periods January 1, 2018 through April 10, 2018 (Predecessor) and April 11, 2018 through December 31, 2018 (Successor) from our audited consolidated financial statements included elsewhere in this prospectus. We have derived our selected historical consolidated balance sheet data as of December 31, 2019 and 2018 from our audited consolidated financial statements included elsewhere in this prospectus.

The significant differences in accounting for the Successor period as compared to the Predecessor period, which were established as part of our acquisition by the Apollo Funds, are in (1) aircraft rent, due to the over-market liabilities related to unfavorable terms of our existing aircraft leases and maintenance reserve payments, which will be amortized on a straight-line basis as a reduction of aircraft rent over the remaining life of each lease, (2) maintenance expenses, due to recognizing a liability (or contra-asset) that will offset expenses for maintenance events incurred by the Successor but paid for by the Predecessor and (3) depreciation and amortization, due to the recognition of our property and equipment and other intangible assets at fair value at the time of the acquisition, which will be amortized through depreciation and amortization on a straight-line basis over their respective useful lives. Please see our audited consolidated financial statements and the related notes included elsewhere in this prospectus. Our historical results are not necessarily indicative of the results that may be expected in the future. The following selected consolidated financial data should be read in conjunction with the section titled “*Management’s Discussion and Analysis of Financial Condition and Results of Operations*” and our audited consolidated financial statements and the related notes included elsewhere in this prospectus.

	<u>Successor</u>	<u>Successor</u>	<u>Predecessor</u>
	<u>For the year ended December 31, 2019</u>	<u>For the period April 11, 2018 through December 31, 2018</u>	<u>For the period January 1, 2018 through April 10, 2018</u>
(in thousands, except per share data)			
<b>Operating Revenues:</b>			
Passenger	\$	\$ 335,824	\$ 172,897
Other		49,107	24,555
Total Operating Revenue		<u>384,931</u>	<u>197,452</u>
<b>Operating Expenses:</b>			
Aircraft Fuel		119,553	45,790
Salaries, Wages, and Benefits		90,263	36,964
Aircraft Rent <sup>(1)</sup>		36,831	28,329
Maintenance <sup>(2)</sup>		15,491	9,508
Sales and Marketing		17,180	10,854
Depreciation and Amortization <sup>(3)</sup>		14,405	2,526
Ground Handling		23,828	8,619
Landing Fees and Airport Rent		25,977	10,481
Special Items, net		(6,706)	271
Other Operating, net		40,877	17,994
Total Operating Expenses		<u>377,699</u>	<u>171,336</u>
Operating Income		<u>7,232</u>	<u>26,116</u>
<b>Non-operating Income (Expense):</b>			
Interest Income	\$	\$ 258	\$ 96
Interest Expense		(6,060)	(339)
Other, net		(1,636)	37
Total Non-operating Expense		<u>(7,438)</u>	<u>(206)</u>



## [Table of Contents](#)

	<u>Successor</u>	<u>Successor</u>	<u>Predecessor</u>
	<u>For the year ended December 31, 2019</u>	<u>For the period April 11, 2018 through December 31, 2018</u>	<u>For the period January 1, 2018 through April 10, 2018</u>
(in thousands, except per share data)			
Income (Loss) before Income Tax		(206)	25,910
Income Tax Expense		161	—
Net Income (Loss)	<u>\$</u>	<u>\$ (367)</u>	<u>\$ 25,910</u>
Net Income (Loss) per share to common stockholders:			
Basic and diluted	<u>\$</u>	<u>\$ (0.15)</u>	<u>\$ 0.26</u>
Weighted average shares outstanding:			
Basic and diluted		2,472	100,000

- (1) Aircraft Rent expense for the Successor period is reduced due to amortization of a liability representing lease rates and maintenance reserves which were higher than market terms of similar leases at the time of our acquisition by the Apollo Funds. This liability was recognized at the time of the acquisition and is being amortized into earnings through a reduction of Aircraft Rent on a straight-line basis over the remaining life of each lease. See Note 2 and Note 3 to our audited consolidated financial statements included elsewhere in this prospectus for additional information.
- (2) Maintenance expense for the Successor period is reduced due to recognizing a liability (or contra-asset) to represent the Successor's obligation to perform planned maintenance events paid for by the Predecessor on leased aircraft at the date of our acquisition by the Apollo Funds. The liability (or contra-asset) is recognized as a reduction to Maintenance expense as reimbursable maintenance events are performed and maintenance expense is incurred. See Note 2 and Note 3 to our audited consolidated financial statements included elsewhere in this prospectus for additional information.
- (3) Depreciation and amortization expense increased in the Successor period due to higher fair values for certain acquired assets and to the amortization of definite-lived intangible assets. See Note 2 to our audited consolidated financial statements included elsewhere in this prospectus for additional information.

	<u>As of December 31,</u>	
	<u>2019</u>	<u>2018</u>
	(in thousands)	
<b>Consolidated Balance Sheet Data:</b>		
Cash and cash equivalents	\$	\$ 29,600
Total assets		675,832
Long-term debt and finance lease obligations, including current portion <sup>(1)</sup>		58,429
Stockholders' equity		235,647

- (1) Finance lease obligations were formerly referred to as capital lease obligations prior to our adoption of the new leasing standard on January 1, 2019. See Note 3 to our audited consolidated financial statements included elsewhere in this prospectus for additional information.

## MANAGEMENT'S DISCUSSION AND ANALYSIS OF FINANCIAL CONDITION AND RESULTS OF OPERATIONS

*You should read the following discussion of our financial condition and results of operations in conjunction with our consolidated financial statements and the related notes thereto included elsewhere in this prospectus. This discussion contains forward-looking statements that involve risk, assumptions and uncertainties, such as statements of our plans, objectives, expectations, intentions and forecasts. Our actual results and the timing of selected events could differ materially from those discussed in these forward-looking statements as a result of several factors, including those set forth under the section of this prospectus titled "Risk Factors" and elsewhere in this prospectus. You should carefully read the "Risk Factors" to gain an understanding of the important factors that could cause actual results to differ materially from our forward-looking statements. Please also see the section of this prospectus titled "Cautionary Note Regarding Forward-Looking Statements."*

### Overview

Sun Country Airlines is a Minnesota-based high-growth, low-cost air carrier focused on serving leisure passengers on flights throughout the United States and to destinations in Mexico, Central America, the Caribbean and Canada. We operate an agile network that includes both our core scheduled service business and our synergistic and profitable charter business. Our model dynamically deploys shared aircraft and flight crews across our service lines with the objective of generating higher returns and margins. We optimize capacity allocation by market, time of year, day of week and line of business by shifting flying to markets during periods of high demand and away from markets during periods of low demand with far greater frequency than other airlines other than Allegiant Travel Company. However, unlike us, Allegiant Travel Company flies to different markets than we do with a basic product, smaller charter business and limited ticket distribution network through its website. Our model includes many of the low-cost structure characteristics of ULCCs (which include Allegiant Travel Company, Spirit Airlines and Frontier Airlines), such as an unbundled product, point-to-point service and a single-family fleet of Boeing 737-NG aircraft, which allow us to maintain a cost base comparable to these ULCCs. However, we offer an elevated product that we believe is superior to the ULCCs and consistent with that of LCCs (which include Southwest Airlines and JetBlue Airways). For example, our product includes more legroom than ULCCs, free beverages, in-flight entertainment and in-seat power, none of which are offered by the ULCCs. The combination of our agile "peak demand" network with our elevated consumer product allows us to generate higher TRASM than ULCCs while maintaining lower CASM ex than LCCs. As a result of our complementary scheduled service, charter and future cargo businesses, agile "peak demand" network and low-cost structure similar to ULCCs and elevated consumer product similar to LCCs, we believe that Sun Country Airlines represents a new breed of hybrid air carrier.

Our agile "peak demand" scheduling strategy is focused on flexing capacity by day of the week, month of the year and line of business to capture what we believe are the most profitable flying opportunities. Our agility is supported by our variable cost structure and the cross utilization of our people and assets between lines of business. Our agile peak demand strategy allows us to generate higher TRASM by focusing on days with stronger demand.

As part of our business transformation, we have reduced our unit costs by outsourcing our Minneapolis station handling, renegotiating our component maintenance agreement, implementing fuel savings initiatives, reducing catering costs and renegotiating distribution contracts, among other cost-saving initiatives. We keep our aircraft ownership costs low by purchasing mid-life Boeing 737 aircraft, which have a lower purchase price than comparable new Boeing 737 aircraft. We operate a single family aircraft fleet which has both operational and cost advantages, such as allowing for optimization of crew scheduling and training and lower maintenance costs. In part due to our cost saving initiatives, our CASM ex has decreased from 7.79 cents for the year ended December 31, 2017 to      cents for the year ended December 31, 2019. We are focused on continuous cost rationalization and identifying potential redundancies or inefficiencies in our operations. Our business model and strategy positions us well to maintain and improve our low CASM despite having lower utilization rates than most of our peers.

In December 2019, we entered into the ATSA with Amazon to provide air cargo transportation services. We expect that the ATSA will result in various benefits including, among others, growth in revenues, improved cash

## [Table of Contents](#)

flows and operating efficiencies. In addition, we expect to further expand our fleet and take delivery of 10 additional Boeing 737-800 aircraft provided by Amazon between the second quarter and the third quarter of 2020. Achieving the anticipated benefits from the agreement is subject to a number of challenges and uncertainties. See *“Risk Factors—The anticipated strategic and financial benefits of the ATSA may not be realized.”* We plan to allocate resources towards the Amazon operations during the ramp-up period, which is expected to extend through the fourth quarter of 2020. Pursuant to the agreement, we are entitled to receive from Amazon upfront payments towards start-up costs, a portion of which was received in 2019, in addition to fixed monthly payments per aircraft and variable payments based on block hours flown. We have not historically had any significant cargo operations, nor have we had main deck cargo operations; however, we expect to leverage our core operations and operational capabilities in executing the additional services for Amazon.

### **Basis of Presentation**

On April 11, 2018, MN Airlines, LLC was acquired by the Apollo Funds. As a result of the change of control, the acquisition was accounted for as a business combination using the acquisition method of accounting, which requires, among other things, that our assets and liabilities be recognized on the consolidated balance sheet at their fair value as of the acquisition date. Accordingly, the financial information provided in this prospectus is presented as “Predecessor” or “Successor” to indicate whether they relate to the period preceding the acquisition or the period succeeding the acquisition, respectively. Additionally, in May 2019, we converted the operating entity of the airline from MN Airlines, LLC d/b/a Sun Country Airlines to Sun Country, Inc. d/b/a Sun Country Airlines.

The comparability of the Successor 2019 period to the Successor 2018 and Predecessor 2018 period may be impacted due to the recognition of assets and liabilities at their fair value at the acquisition date. The significant differences in accounting for the Successor period as compared to the Predecessor period, which were established as part of our acquisition by the Apollo Funds, are in (1) aircraft rent, due to the over-market liabilities related to unfavorable terms of our existing aircraft leases and maintenance reserve payments, which will be amortized on a straight-line basis as a reduction of aircraft rent over the remaining life of each lease, (2) maintenance expenses, due to recognizing a liability (or contra-asset) that will offset expenses for maintenance events incurred by the Successor but paid for by the predecessor and (3) depreciation and amortization, due to the recognition of our property and equipment and other intangible assets at fair value at the time of the acquisition, which will be amortized through depreciation and amortization on a straight-line basis over their respective useful lives. See Note 2 to our audited consolidated financial statements included elsewhere in this prospectus for additional information.

The financial information, accounting policies and activities of the Successor and Predecessor are referred to those of the Company. The Successor adopted the Predecessor’s accounting policies. See Note 3 to our audited consolidated financial statements included elsewhere in this prospectus for additional information.

### **Year in Review**

Since late 2017, we have been focused on implementing our high-growth, low-cost strategy by transforming our business model to provide a high quality travel experience at affordable fares. In the last two years, we invested significantly in mid-life Boeing 737-800 aircraft, new aircraft interiors and seat densification and other growth-oriented and cost-saving initiatives. Additionally, we have meaningfully expanded our ancillary product offerings, which allows us to stimulate passenger demand for our product through low base fares and enables passengers to identify, select and pay for the products and services they want to use, which is further complemented by the overhaul of our reservation and distribution system and new website in 2019. We believe a key component of our success is establishing Sun Country as a high growth, low-cost carrier in the United States by attracting customers with low fares and garnering repeat business by delivering a high quality passenger experience, offering state-of-the-art seat equipment, free streaming in-flight entertainment to passenger devices, seat recline and seat-back power in all of our aircraft, none of which are offered by ULCCs. Furthermore, we

## [Table of Contents](#)

redesigned our loyalty program in the fourth quarter of 2018 to be simple and family friendly, and improved the flexibility of our cancellation policy.

During 2019, we reconfigured the seat density of substantially all our aircraft to 183 seats, and subsequently further increased the seat density of our fleet to 186 seats. At 186 seats, we offer two different seat categories: Best and Standard. The Best category includes preferred boarding, one complimentary alcoholic beverage, four inches of extra legroom and 150% extra recline.

Our revenue has grown from \$560 million in 2017 to \$        million in 2019 primarily as a result of our increased capacity following the expansion of our network. Our ASMs increased from 5.3 billion in 2017 to 7.1 billion in 2019, driven primarily by an increase in average seat density of our aircraft and an increase in the number of flights and block hours. Our scheduled service revenue has grown from \$372 million in 2017 to \$        million in 2019. We have focused on the expansion of our network on point-to-point travel outside of MSP to leverage seasonal demand where other airlines are unable to respond effectively to the needs of the market. Since implementing our non-MSP route strategy in early 2018, we grew this service to 10% of scheduled service block hours in 2018 and further increased non-MSP service to 20% of scheduled service block hours in 2019. Additionally, we meaningfully expanded our ancillary product offering in the last two years by introducing carry-on and checked bag fees and increasing our buy-on-board options. These efforts led to an increase in ancillary revenue from \$33 million in 2017 to \$        million in 2019. Ancillary revenue per passenger increased from \$13.34 to \$        from 2017 to 2019. Our charter service revenue has grown from \$132 million in 2017 to \$        million in 2019 primarily due to an increase in the number of charter flights for our casino and sports customers and the U.S. Department of Defense. Other revenue declined from \$22 million in 2017 to \$        million in 2019 primarily due to lower net revenues from our Sun Country Vacations products along with lower cargo and mail revenues.

Our cost savings initiatives have contributed to reductions in operating costs, which is reflected in a decrease in CASM ex from 7.79 cents in 2017 to        cents in 2019. Accordingly, we are able to offer highly competitive low-cost fares to our customers and have reduced our average fare per scheduled service passenger from \$148.60 in 2017 to \$        in 2019. The primary drivers of our cost savings were our outsourcing of Minneapolis station handling, reworking of spare parts agreements, fuel savings initiatives, catering cost reductions and renegotiation of distribution contracts. Our cost structure has resulted in our ability to maintain low costs at lower utilizations, which enables us to tailor schedules to peak periods of demand. These efforts have resulted in our operating margin improving from 5.3% in 2017 to        % in 2019.

We transformed our front- and back-end technology, which laid the foundation for future growth and improved merchandising. In June 2019, we introduced our new website which makes booking and travel easier and more enjoyable for our customers. Driving ticket sales through our own website increases our profitability as our website is our lowest cost distribution center, and our redesigned website led to an increased percentage of visits to our website that result in an airfare purchase and increased bookings on mobile devices. We also completed the implementation of a robust and scalable reservation and distribution system to improve our ability to issue, track and accept electronic tickets, conduct check-in, board and manage our passengers and access to GDSs, which we expect to expand our services to potential passengers.

### **Fleet Plan**

During 2019 we completed the transition of our fleet to substantially all mid-life Boeing 737-800s, a Boeing 737-NG variant, and as of December 31, 2019 we operated a fleet of 31 aircraft, including two seasonal aircraft. The use of a single aircraft variant allows for additional cost efficiencies as a result of simplified scheduling, maintenance, flight operations and training.

The transition to 737-800s also resulted in an increase in seat density on substantially all of our aircraft to 183 seats in 2019, which will provide for greater fuel efficiency per ASM. We further increased the seat density of our fleet to 186 seats as a result of additional seat reconfiguration.

## [Table of Contents](#)

We currently have plans to grow our 2020 operating capacity as we take delivery of additional aircraft and make changes to our network. We have agreements in place to add four aircraft in 2020, with an offset of reducing our seasonal fleet by two aircraft, and we have identified commercial opportunities to add between three and five additional aircraft to our fleet in 2021. We then plan to grow the passenger fleet to 50 aircraft by the end of 2023. We expect to finance all of our additional aircraft through debt or finance leases, though we also may enter into new operating leases on an opportunistic basis. Additionally, we intend to buy out certain of our existing aircraft currently financed under operating lease agreements over the next several years using mortgage based financings or using enhanced equipment trust certificates, or EETC, issued through pass-through trusts, which are structured to provide for certain credit enhancements that reduce the risks to the purchasers of the trust certificates and, as a result, reduce the cost of our aircraft financing. We expect to further expand our fleet through our agreement to provide air cargo services to Amazon. We plan to take delivery of an additional 10 Boeing 737-800 aircraft provided by Amazon between the second and third quarters of 2020.

Our strategy is to target mid-life aircraft due to the lower ownership costs relative to new aircraft and the flexibility associated with a liquid market for mid-life aircraft allowing us to adjust the composition of our fleet with limited forward commitments. The average age of the passenger aircraft in our fleet as of December 31, 2019 was approximately 15 years, and we do not expect this to change in the near future. We view aircraft ownership as preferable to leasing due to the increased level of control to optimize and utilize maintenance value, competitive financing costs at investment grade rates, and flexibility to sell or retire aircraft at any time.

Our fleet management strategy also includes making use of short-term leases to support increased seasonal demand. For example, our 737-800 seasonal lease agreement allows us to increase our capacity during our busier winter months in an affordable and flexible manner due to the counter cyclical nature of our networks.

### **Trends and Uncertainties Affecting Our Business**

We believe our operating performance is driven by various factors that typically affect airlines and their markets, including trends which affect the broader travel industry, as well as trends which affect the specific markets and customer base that we target. The following key factors may affect our future performance:

*Competition.* The airline industry is highly competitive. The principal competitive factors in the airline industry are the fare, flight schedules, number of routes served from a city, frequent flyer programs, product and passenger amenities, customer service, fleet type and reputation. Price competition occurs on a market-by-market basis through price discounts, changes in pricing structures, fare matching, target promotions and frequent flyer initiatives. The airline industry is particularly susceptible to price discounting because once a flight is scheduled, airlines incur only nominal incremental costs to provide service to passengers occupying otherwise unsold seats. Airlines typically use discounted fares and other promotions to stimulate traffic during normally slower travel periods to generate cash flow and to increase PRASM.

The availability of low-priced fares coupled with an increase in domestic capacity has led to dramatic changes in pricing behavior in many U.S. markets. Legacy network airlines have also begun matching LCC and ULCC pricing on portions of their marginal unsold capacity, which we expect to continue for the foreseeable future. Many domestic carriers have also begun matching lower cost airline pricing, either with limited or unlimited inventory. Moreover, many other airlines have unbundled their services, at least in part, by charging separately for services such as baggage and advance seat selection, which previously were offered as a component of their base fares. This unbundling and other cost-reducing measures could enable competitor airlines to reduce fares on routes that we serve, which could materially adversely affect our business. Refer to “*Risk Factors*” included elsewhere in this prospectus for additional information.

*Aircraft Fuel.* Fuel expense represents our single largest operating expense. Jet fuel prices and availability are subject to market fluctuations, refining capacity, periods of market surplus and shortage and demand for heating oil, gasoline and other petroleum products, as well as meteorological, economic and political factors and

## Table of Contents

events occurring throughout the world, which we can neither control nor accurately predict. The future cost and availability of jet fuel cannot be predicted with any degree of certainty. For the year ended December 31, 2019, approximately % of our fuel was purchased from two vendors. This concentration is largely driven by our substantial operations in MSP.

To hedge the economic risk associated with volatile aircraft fuel prices, we periodically enter into fuel collars, which allow us to reduce the overall cost of hedging, but may prevent us from participating in the benefit of downward price movements. In the past, we have also entered into fuel option and swap contracts. As of December 31, 2019, we had hedges in place for approximately 61% of our projected fuel requirements for scheduled service operations in 2020, with all of our then existing options expected to be exercised or expire by the end of 2021. Generally, our charter operations have pass-through provisions for fuel costs, and therefore we do not hedge our fuel requirements for that component of our business.

Our fuel hedging strategy is dependent upon many factors, including our assessment of market conditions for fuel, our access to the capital necessary to support margin requirements, the pricing of hedges and other derivative products in the market and our overall appetite for risk. We believe our strategy economically hedges against unexpected price volatility. However, we cannot be assured that our hedging strategy will be effective or that we will continue our strategy in the future.

We do not apply hedge accounting on our fuel derivative contracts, and as a result, changes in the fair value of our fuel derivative contracts are recorded within the period as a component of aircraft fuel expense. See Note 9 to our audited consolidated financial statements included elsewhere in this prospectus for further discussion of our hedging activity.

*Seasonality and Volatility.* The airline industry is affected by economic cycles and trends, where unfavorable economic conditions have historically reduced airline travel spending. For most VFR travel, and cost-conscious leisure travelers, travel is a discretionary expense, and although we believe low-cost airlines are best suited to attract travelers during periods of unfavorable economic conditions as a result of such carriers' low base fares, travelers have often elected to replace air travel at such times with car travel or other forms of ground transportation or have opted not to travel at all.

Our operations are highly seasonal as we manage our route network and aircraft fleet to match demand. As a result, our results of operations for any interim period are not necessarily indicative of those for the entire year. We generally expect demand to be greater in the winter season due to our customers' propensity to travel to warm leisure destinations from MSP, and in the summer season due to increased demand for VFR and leisure travel. We continually work to meet the need of both VFR and leisure travelers. Accordingly, our network of destinations includes those popular year-round, as well as those that are highly seasonal, and we adapt our flight schedule according to expected patterns of demand throughout the year. Understanding the purpose of our customers' travel and our ability to adjust capacity accordingly helps us optimize destinations, strengthen our network and increase unit revenues. We will look to incorporate new destinations with seasonality that complements our current mix of customers and destinations to mitigate the overall impact of seasonality on our business. Part of our network strategy includes expanding our presence outside of MSP to leverage seasonal demands peaks where other airlines are unable to effectively respond to the needs of the market. For example, we expect to continue to target cold-to-warm leisure markets in the upper Midwest, where we believe we have a competitive advantage due to our cold weather operational expertise and strong brand recognition, as well as other large, fragmented markets. We also continue to use seasonal aircraft leases to accommodate increased demand during peak seasons. Furthermore, our charter operations complement our network strategy by maintaining aircraft and crew utilization in periods when scheduled service would be less profitable.

*Labor.* The airline industry is heavily unionized and our business is labor intensive. The wages, benefits and work rules of unionized airline industry employees are determined by CBAs. Relations between air carriers and labor unions in the United States are governed by the RLA. Under the RLA, CBAs generally contain "amendable

## [Table of Contents](#)

dates” rather than expiration dates and the RLA requires that a carrier maintain the existing terms and conditions of employment following the amendable date through a multi-stage and usually lengthy series of bargaining processes overseen by the NMB. This process continues until either the parties have reached agreement on a new CBA or the parties have been released to “self-help” by the NMB. In most circumstances the RLA prohibits strikes, however, after the release by the NMB, carriers and unions are free to engage in self-help measures such as lockouts and strikes.

As of December 31, 2019, approximately 59% of our employees were represented by three union groups. The union groups include our pilots, represented by the Air Line Pilots Association, our flight attendants, represented by the International Brotherhood of Teamsters, and our dispatchers, represented by the Transport Workers Union. Our collective bargaining agreement with our dispatchers became amendable on September 27, 2017 and we entered into NMB mediation with the union representing this group on September 19, 2018. On December 3, 2019 our dispatchers approved a new contract, now amendable on November 14, 2024. Our collective bargaining agreement with our flight attendants is currently amendable and we are in negotiations with the union representing this group. Our collective bargaining agreement with our pilots is amendable on October 31, 2020. If we are unable to reach an agreement with the respective unions in current or future negotiations regarding the terms of their CBAs, we may be subject to operational slowdowns or stoppages, which is likely to adversely affect our ability to conduct business. Any agreement we do reach could increase our labor and related expenses.

*Aircraft Maintenance.* The amount of total maintenance costs and related depreciation of significant maintenance expense is subject to variables such as estimated utilization rates, average stage length, the interval between significant maintenance events, the size, age and makeup of our fleet, maintenance holidays, government regulations and the level of unscheduled maintenance events and their actual costs.

Maintenance expense grew through 2019 and 2018 mainly as a result of a growing fleet, a trend that we expect to continue for the next several years as we take delivery of additional aircraft.

As of December 31, 2019, the average age of our passenger aircraft was approximately 15 years.

The terms of our aircraft lease agreements generally provide that we pay maintenance reserves, also known as supplemental rent, monthly to our lessors to be held as collateral in advance of significant maintenance activities required to be performed by us, resulting in our recording significant lessor maintenance deposits on our consolidated balance sheet. Some portions of the maintenance reserve payments are fixed contractual amounts, while others are based on a utilization measure, such as actual flight hours or cycles, and vary by agreement. As a result, for leases requiring maintenance reserves, the cash costs of scheduled significant maintenance events are paid in advance of the recognition of the maintenance event in our results of operations. For more information, refer to “*Critical Accounting Policies and Estimates—Aircraft Maintenance.*”

## **Components of Operations**

### ***Operating Revenues***

*Scheduled service.* Scheduled service revenue consists of base fares, unused and expired passenger credits and other expired travel credits.

*Ancillary.* Ancillary revenue consists of revenue generated from air travel-related services such as baggage fees, seat selection and upgrade fees, itinerary service fees, on-board sales and sales of trip insurance.

*Charter service.* Charter service revenue consists of revenue earned from our charter operations, primarily generated through our service to the U.S. Department of Defense, collegiate and professional sports teams and casinos.



## [Table of Contents](#)

*Other.* Other revenue consists primarily of revenue from services in connection with our Sun Country Vacations products, including organizing ground services, such as hotel, car and transfers. Other revenue also includes services not directly related to providing passenger services such as the advertising, marketing and brand elements resulting from our co-branded credit card program. This component of our revenues also includes revenue from mail and cargo operations through the use of cargo space on regularly scheduled passenger aircraft.

### ***Operating Expenses***

*Aircraft Fuel.* Aircraft fuel expense is our single largest operating expense. It includes jet fuel, federal and state taxes, other fees and the mark-to-market gains and losses associated with our fuel derivative contracts as we do not apply hedge accounting. Aircraft fuel expense can be volatile, even between quarters, due to price changes and mark-to-market gains and losses in the value of the underlying derivative instruments as crude oil prices and refining margins increase or decrease.

*Salaries, Wages, and Benefits.* Salaries, wages, and benefits expense includes salaries, hourly wages, bonuses, equity-based compensation and profit sharing paid to employees for their services, as well as related expenses associated with medical benefits, employee benefit plans, employer payroll taxes and other employee related costs.

*Aircraft Rent.* Aircraft rent expense consists of monthly lease charges for aircraft and spare engines under the terms of the related operating leases and is recognized on a straight-line basis. Aircraft rent expense also includes supplemental rent, which consists of maintenance reserves paid to aircraft lessors in advance of the performance of significant maintenance activities that are not probable of being reimbursed to us by the lessor during the lease term, as well as lease return costs, which consist of all costs that would be incurred at the return of the aircraft, including costs incurred to return the airframe and engines to the condition required by the lease. Aircraft rent expense is partially offset by the amortization of over-market liabilities related to unfavorable terms of our operating leases and maintenance reserves which existed as of the date of our acquisition by the Apollo Funds, which were established as part of the acquisition. See Note 2 to our audited consolidated financial statements included elsewhere in this prospectus for further information on the over-market liabilities.

*Maintenance.* Maintenance expense includes the cost of all parts, materials and fees for repairs performed by us and our third-party vendors to maintain our fleet. It excludes direct labor cost related to our own mechanics, which are included in salaries, wages and benefits expense. It also excludes maintenance expenses, which are deferred based on the built-in overhaul method for owned aircraft and subsequently amortized as a component of depreciation and amortization expense. Our maintenance expense is reduced due to recognizing a liability (or contra-asset) that offsets expenses for maintenance events incurred by the Successor but paid for by the Predecessor, established as part of our acquisition by the Apollo Funds for aircraft in our fleet as of the date of the acquisition. For more information on these accounting methods, refer to “—Critical Accounting Policies and Estimates—Aircraft Maintenance.”

*Sales and Marketing.* Sales and marketing expense includes credit card processing fees, travel agent commissions and related global distribution systems fees, advertising, sponsorship and distribution costs, such as the costs of our call centers, and costs associated with our frequent flier program. It excludes related salary and wages of personnel, which are included in salaries benefits and wages expense.

*Depreciation and Amortization.* Depreciation and amortization expense includes depreciation of fixed assets we own and leasehold improvements, as well as the amortization of capitalized software costs and finite-lived intangible assets. It also includes the amortization of significant maintenance expenses we deferred under the built-in overhaul method for owned aircraft.

*Ground Handling.* Ground handling includes ground activities including baggage handling, ticket counter and other ground services.



## [Table of Contents](#)

*Landing Fees and Airport Rent.* Landing fees and airport rent includes aircraft landing fees and charges for the use of airport facilities.

*Special Items, net.* Special items, net reflects expenses, or credits to expense, that are not representative of our ongoing costs for the period presented.

*Other Operating.* Other operating expenses include crew and other employee travel, interrupted trip expenses, information technology, property taxes and insurance, including hull-liability insurance, supplies, legal and other professional fees, facilities and all other administrative and operational overhead expenses.

### *Non-operating Income (Expense)*

*Interest Income.* Interest income includes interest on our cash and equivalent and investment balances. Interest income is generally immaterial to our results of operations, reflecting the current low interest rate environment and our unrestricted cash balances.

*Interest Expense.* Interest expense includes interest related to our outstanding debt and our finance and capital leases.

*Other, net.* Other expenses include activities not classified in any other area of the consolidated statements of operations, such as gain or loss on sale or retirement of assets and certain consulting expenses.

### *Income Taxes*

During the Predecessor period, we were taxed as a limited liability company as our prior owners had elected to be treated as a partnership under the Internal Revenue Code of 1986, as amended, or the “Code”, whereby our income or loss was reported by our SCA common stockholders on their individual tax returns. Therefore, no provision for income tax expense was included on the consolidated statements of operations during the Predecessor 2018 period.

At the acquisition date, we elected to be treated as a corporation for income tax purposes. Therefore, within the Successor periods we account for income taxes using the asset and liability method. We record a valuation allowance to reduce the deferred tax assets reported if, based on the weight of the evidence, it is more likely than not that some portion or all of the deferred tax assets will not be realized. We record deferred taxes based on differences between the financial statement basis and tax basis of assets and liabilities and available tax loss and credit carryforwards. In assessing our ability to utilize our deferred tax assets, we consider whether it is more likely than not that some or all of the deferred tax assets will be realized. We consider all available evidence, both positive and negative, in determining future taxable income on a jurisdiction by jurisdiction basis.

## **Results of Operations**

### *Successor 2019 period and Successor and Predecessor 2018 periods*

	<u>Successor</u>		<u>Predecessor</u>
	<u>For the year ended December 31, 2019</u>	<u>For the period April 11, 2018 through December 31, 2018</u>	<u>For the period January 1, 2018 through April 10, 2018</u>
(in thousands)			
<b>Operating revenues:</b>			
Scheduled service	\$	\$ 224,507	\$ 132,233
Ancillary		41,065	15,671

[Table of Contents](#)

	Successor		Predecessor
	For the year ended December 31, 2019	For the period April 11, 2018 through December 31, 2018	For the period January 1, 2018 through April 10, 2018
(in thousands)			
Charter service		111,317	40,663
Other		8,042	8,885
<b>Total operating revenues</b>	<b>\$</b>	<b>\$ 384,931</b>	<b>\$ 197,452</b>
<b>Operating expenses:</b>			
Aircraft fuel	\$	\$ 119,553	\$ 45,790
Salaries, wages, and benefits		90,263	36,964
Aircraft rent <sup>(1)</sup>		36,831	28,329
Maintenance <sup>(2)</sup>		15,491	9,508
Sales and marketing		17,180	10,854
Depreciation and amortization <sup>(3)</sup>		14,405	2,526
Ground handling		23,828	8,619
Landing fees and airport rent		25,977	10,481
Special items, net		(6,706)	271
Other operating		40,877	17,994
<b>Total operating expenses</b>		<b>377,699</b>	<b>171,336</b>
<b>Operating income</b>	<b>\$</b>	<b>\$ 7,232</b>	<b>\$ 26,116</b>
<b>Non-operating income (expense):</b>			
Interest income	\$	\$ 258	\$ 96
Interest expense		(6,060)	(339)
Other, net		(1,636)	37
<b>Total non-operating expense</b>		<b>(7,438)</b>	<b>(206)</b>
Income before income tax		(206)	25,910
Income tax expense		161	—
<b>Net income</b>	<b>\$</b>	<b>\$ (367)</b>	<b>\$ 25,910</b>
<b>Other Financial Data:</b>			
Adjusted Net Income <sup>(4)</sup>	\$	\$ (5,871)	\$ 26,181
Adjusted EBITDAR <sup>(4)</sup>		49,688	57,279

- (1) Aircraft Rent expense for the Successor period is reduced due to amortization of a liability representing lease rates and maintenance reserves which were higher than market terms of similar leases at the time of our acquisition by the Apollo Funds. This liability was recognized at the time of the acquisition and is being amortized into earnings through a reduction of Aircraft Rent on a straight-line basis over the remaining life of each lease. See Note 2 and Note 3 to our audited consolidated financial statements included elsewhere in this prospectus for additional information.
- (2) Maintenance expense for the Successor period is reduced due to recognizing a liability (or contra-asset) to represent the Successor's obligation to perform planned maintenance events paid for by the Predecessor on leased aircraft at the date of our acquisition by the Apollo Funds. The liability (or contra-asset) is recognized as a reduction to Maintenance expense as reimbursable maintenance events are performed and maintenance expense is incurred. See Note 2 and Note 3 to our audited consolidated financial statements included elsewhere in this prospectus for additional information.
- (3) Depreciation and amortization expense increased in the Successor period due to higher fair values for certain acquired assets and to the amortization of definite-lived intangible assets. See Note 2 to our audited consolidated financial statements included elsewhere in this prospectus for additional information.
- (4) See "—Non-GAAP Financial Measures" for definitions of these measures and reconciliations to the most comparable GAAP metric.

## [Table of Contents](#)

### Operating Revenues

(in thousands)	Successor		Predecessor
	For the year ended December 31, 2019	For the period April 11, 2018 through December 31, 2018	For the period January 1, 2018 through April 10, 2018
<b>Operating revenues:</b>			
Scheduled service	\$	\$ 224,507	\$ 132,233
Ancillary		41,065	15,671
Charter service		111,317	40,663
Other		8,042	8,885
<b>Total operating revenues</b>	<b>\$</b>	<b>\$ 384,931</b>	<b>\$ 197,452</b>

Total operating revenues were \$ million for the Successor 2019 period, \$384.9 million for the Successor 2018 period and \$197.5 million for the Predecessor 2018 period. Scheduled service revenue was \$ million for the Successor 2019 period, \$224.5 million for the Successor 2018 period and \$132.2 million for the Predecessor 2018 period. Ancillary revenue was \$ million for the Successor 2019 period, \$41.1 million for the Successor 2018 period and \$15.7 million for the Predecessor 2018 period. Charter service revenue was \$ million for the Successor 2019 period, \$111.3 million for the Successor 2018 period and \$40.7 million for the Predecessor 2018 period. Other revenue was \$ million for the Successor 2019 period, \$8.0 million for the Successor 2018 period and \$8.9 million for the Predecessor 2018 period.

The increase in scheduled service revenue was primarily related to increases in our capacity and departures along with an increase in load factor. Our scheduled service capacity, as measured by ASMs, increased by 29% as a result of additional aircraft in service and increases in the number of seats on board. We undertook the reconfiguration of our fleet to a high-density seating configuration, substantially completed in 2019, which led to an increase in our number of scheduled service passengers. Our total scheduled service passengers increased to 3.6 million from 2.6 million. The increase in scheduled service revenue was partially offset by a % decrease in average scheduled passenger fare from \$136.42, driven by our low-cost pricing strategy. PRASM decreased by cents, or %, largely due to the lower passenger fares, partially offset by an increase in load factor, which increased to 82.5% from 82.4%.

The increase in ancillary revenue was driven by the unbundling of our services to improve our product segmentation in January 2018, which previously were offered as a component of the base fares. Our focus on ancillary services has driven higher ancillary revenue on a per passenger basis to \$ from \$21.70.

The increase in our charter service revenue was primarily due to an increase in the number of charter flights for our casino and sports customers and the U.S. Department of Defense.

The decrease in our other revenue was primarily due to lower bookings for our Sun Country Vacations products primarily due to transition issues with our new booking system.

## [Table of Contents](#)

### Operating Expenses

(in thousands)	<u>Successor</u> For the year ended December 31, 2019	<u>Successor</u> For the period April 11, 2018 through December 31, 2018	<u>Predecessor</u> For the period January 1, 2018 through April 10, 2018
<b>Operating expenses:</b>			
Aircraft fuel	\$	\$ 119,553	\$ 45,790
Salaries, wages and benefits		90,263	36,964
Aircraft rent		36,831	28,329
Maintenance		15,491	9,508
Sales and marketing		17,180	10,854
Depreciation and amortization		14,405	2,526
Ground handling		23,828	8,619
Landing fees and airport rent		25,977	10,481
Special items, net		(6,706)	271
Other operating		40,877	17,994
<b>Total Operating expenses</b>	<u>\$</u>	<u>\$ 377,699</u>	<u>\$ 171,336</u>

*Aircraft Fuel.* Aircraft fuel expense was \$ million for the Successor 2019 period, \$119.6 million for the Successor 2018 period and \$45.8 million for the Predecessor 2018 period. Our fuel gallons consumed increased by 20.1% due to our increased level of operations. The average price per gallon of fuel declined by 3.4%, partially offsetting the increased usage. Aircraft fuel expense also includes unrealized mark-to-market gains or losses from fuel derivative contracts associated with our economic fuel hedges. This impact was a gain of \$ million in the Successor 2019 period, a loss of \$12 million in the Successor 2018 period and no impact in the Predecessor 2018 period.

*Salaries, Wages and Benefits.* Salaries, wages and benefits expense was \$ million for the Successor 2019 period, \$90.3 million for the Successor 2018 period and \$37.0 million for the Predecessor 2018 period. Expenses increased primarily due to higher costs for our pilots and flight attendants due to contractual rate increases and expanded operations, and higher general and administration staffing along with the full year impact of the management bonus and stock compensation plans introduced during the Successor 2018 period. The increase was partially offset by lower headcount as a result of outsourcing certain ground operations.

*Aircraft Rent.* Aircraft rent expense was \$ million for the Successor 2019 period, \$36.8 million for the Successor 2018 period and \$28.3 million for the Predecessor 2018 period. Aircraft rent expense decreased primarily due to a change in the composition of our aircraft fleet between leased aircraft (for which rent expense is recorded under aircraft rent) and purchased aircraft (for which depreciation expense is recorded under depreciation and amortization). The decrease was primarily a result of purchasing one aircraft previously on an operating lease, and returning three leased 737-700 aircraft during the Successor 2019 period. In connection with accounting for our acquisition by the Apollo Funds, we recognized a liability representing lease rates and maintenance reserves which are unfavorable compared with market terms of similar leases. This liability is being amortized into earnings through a reduction of aircraft rent on a straight-line basis over the remaining life of each lease in the Successor periods.

*Maintenance.* Maintenance materials and repair expense was \$ million for the Successor 2019 period, \$15.5 million for the Successor 2018 period and \$9.5 million for the Predecessor 2018 period. The increase was primarily due to the timing and number of maintenance events, including two additional engine overhauls and four additional heavy checks in the Successor 2019 period. Maintenance materials expense also increased due to additional events, partially offset by reduced expenses under our outsourced parts supply agreement. The increase in maintenance expense was also partially offset in the Successor 2019 period and the Successor 2018 period by the reduction of the maintenance liability (or contra-asset) that was recorded as a result

## [Table of Contents](#)

of acquisition accounting for the acquisition by the Apollo Funds. The maintenance liability (or contra-asset) is reduced as reimbursable maintenance events are performed and maintenance expense is incurred.

*Sales and Marketing.* Sales and marketing expense was \$            million for the Successor 2019 period, \$17.2 million for the Successor 2018 period and \$10.9 million for the Predecessor 2018 period. The increase was primarily due to higher sales that directly drives higher credit card fees, partially offset by a decrease in booking fees as a result of a higher proportion of bookings on our redesigned website, as our website is our lowest cost distribution channel, and more favorable renegotiated contracts with third-party distribution channels.

*Depreciation and Amortization.* Depreciation and amortization expense was \$            million for the Successor 2019 period, \$14.4 million for the Successor 2018 period and \$2.5 million for the Predecessor 2018 period. The increase was primarily due to the impact of a change in the composition of the fleet from all leased to an increased number of owned aircraft, and the impact of acquisition accounting and the resulting increase to the book value of our assets. Depreciation and amortization includes \$            million and \$2.3 million of amortization in the Successor 2019 period and Successor 2018 period, respectively, related to definite lived intangible assets recorded as a result of purchase price accounting for our acquisition by the Apollo Funds. There was no comparable amortization in the Predecessor 2018 period.

*Ground Handling.* Ground handling expense was \$            million for the Successor 2019 period, \$23.8 million for the Successor period and \$8.6 million for the Predecessor 2018 period. The increase was due to the increase in departures and additional airports in our route network for both our scheduled service and charter operations. We fully outsourced MSP ground handling services in May 2018, contributing to a reduction in salaries, wages and benefits but resulting in higher ground handling expenses.

*Landing Fees and Airport Rent.* Landing fees and airport rent was \$            million for the Successor 2019 period, \$26.0 million for the Successor 2018 period and \$10.5 million for the Predecessor 2018 period. The increase was due to the increase in departures and additional airports in our route network.

*Special Items, net.* Special items, net includes the impact of changes to the terms of our rewards program recognized in the Successor 2018 period. The program changes included a net reduction in expenses of \$8.5 million due to the earlier expiration of outstanding points, partially offset by an increase in expense as a result of improved terms for members' redemption of points. We also recognized expense of \$1.7 million for the Successor 2018 period and \$0.3 million for the Predecessor 2018 period related to early-out and employee separation expenses incurred in connection with outsourcing certain operations and other employee initiatives. These efforts were primarily related to airport station, flight attendants and ground handling employees.

*Other Operating Expenses.* Other operating expenses was \$            million for the Successor 2019 period, \$40.9 million for the Successor 2018 period and \$18.0 million for the Predecessor 2018 period. The increase was primarily due to our higher level of operations.

### *Non-operating Income (Expense)*

(in thousands)	Successor For the year ended December 31, 2019	Successor For the period April 11, 2018 through December 31, 2018	Predecessor For the period January 1, 2018 through April 10, 2018
<b>Non-operating Income (Expense):</b>			
Interest income	\$	\$ 258	\$ 96
Interest expense		(6,060)	(339)
Other, net		(1,636)	37
<b>Total Non-operating Expenses</b>	<b>\$</b>	<b>\$ (7,438)</b>	<b>\$ (206)</b>

## [Table of Contents](#)

*Interest Income.* Interest income increased but was immaterial for the Successor 2019 period, the Successor 2018 period and the Predecessor 2018 period. The increases in the Successor 2018 and Successor 2019 periods relate to higher cash balances.

*Interest Expense.* Interest expense was \$            million for the Successor 2019 period, \$6.1 million for the Successor 2018 period and \$0.3 million for the Predecessor 2018 period. The increase was primarily due to finance leases and to debt issued for the acquisition of new aircraft and spare engines during the Successor 2019 period and the Successor 2018 period, including new debt incurred in connection with the 2019-01 EETC.

*Other, net.* Other, net was \$            million for the Successor 2019 period, expense of \$1.6 million in the Successor 2018 period and income of \$37 thousand for the Predecessor 2018 period, primarily due to miscellaneous income in the Successor 2019 period and Predecessor 2018 periods, and miscellaneous expense in the Successor 2018 period.

### *Income Taxes*

In the Successor 2019 period, our effective tax rate was    %. Our tax rate can vary depending on the amount of income we earn in each state and the state tax rate applicable to such income. We were taxed as a limited liability company during the 2018 Predecessor period, and therefore, no provision for income tax expense was included on the consolidated statements of operations for that period.

[Table of Contents](#)

*Interim Successor 2019 Period and Interim Successor and Predecessor 2018 Periods*

	Interim Successor		Predecessor
	For the nine months ended September 30, 2019	For the period April 11, 2018 through September 30, 2018	For the period January 1, 2018 through April 10, 2018
(in thousands)			
<b>Operating revenues:</b>			
Scheduled service	\$ 312,493	\$ 147,130	\$ 132,234
Ancillary	89,119	24,870	15,670
Charter service	125,715	72,114	40,663
Other	10,193	4,544	8,885
<b>Total operating revenues</b>	<b>\$ 537,520</b>	<b>\$ 248,658</b>	<b>\$ 197,452</b>
<b>Operating expenses:</b>			
Aircraft fuel	\$ 127,338	\$ 67,390	\$ 45,790
Salaries, wages, and benefits	105,668	57,114	36,964
Aircraft rent <sup>(1)</sup>	37,959	23,543	28,329
Maintenance <sup>(2)</sup>	25,041	10,116	9,508
Sales and marketing	27,414	10,465	10,854
Depreciation and amortization <sup>(3)</sup>	25,371	8,250	2,526
Ground handling	31,009	14,686	8,619
Landing fees and airport rent	33,730	16,139	10,481
Special items, net	6,378	1,757	271
Other operating	51,094	22,889	17,994
<b>Total operating expenses</b>	<b>471,002</b>	<b>232,349</b>	<b>171,336</b>
<b>Operating income</b>	<b>\$ 66,518</b>	<b>\$ 16,309</b>	<b>\$ 26,116</b>
<b>Non-operating income (expense):</b>			
Interest income	\$ 618	\$ 118	\$ 96
Interest expense	(12,700)	(2,823)	(339)
Other, net	(906)	(2,170)	37
<b>Total non-operating expense</b>	<b>(12,988)</b>	<b>(4,875)</b>	<b>(206)</b>
Income before income tax	53,530	11,434	25,910
Income tax expense	12,476	2,783	—
<b>Net income</b>	<b>\$ 41,054</b>	<b>\$ 8,651</b>	<b>\$ 25,910</b>
<b>Other Financial Data:</b>			
<b>Adjusted Net Income<sup>(4)</sup></b>	<b>\$ 47,531</b>	<b>\$ 10,004</b>	<b>\$ 26,181</b>
<b>Adjusted EBITDAR<sup>(4)</sup></b>	<b>\$ 137,353</b>	<b>\$ 47,689</b>	<b>\$ 57,279</b>

- (1) Aircraft Rent expense for the Successor periods ended September 30, 2019 and 2018 is reduced due to amortization of a liability representing lease rates and maintenance reserves which were higher than market terms of similar leases at the time of our acquisition by the Apollo Funds. This liability was recognized at the time of the acquisition and is being amortized into earnings through a reduction of Aircraft Rent on a straight-line basis over the remaining life of each lease. See Notes 2 and 3 to our audited consolidated financial statements and Notes 2 and 12 to our interim condensed consolidated financial statements included elsewhere in this prospectus for additional information.
- (2) Maintenance expense for the Successor periods ended September 30, 2019 and 2018 is reduced due to recognizing a liability (or contra-asset) to represent the Successor's obligation to perform planned maintenance events paid for by the Predecessor on leased aircraft at the date of our acquisition by the Apollo Funds. The liability (or contra-asset) is recognized as a reduction to Maintenance expense as reimbursable maintenance events are performed and maintenance expense is incurred. See Notes 2 and 3 to our audited consolidated financial statements and Notes 2 and 12 to our interim condensed consolidated financial statements included elsewhere in this prospectus for additional information.
- (3) Depreciation and amortization expense increased in the Successor periods ended September 30, 2019 and 2018 due to higher fair values for certain acquired assets and to the amortization of definite-lived intangible assets. See Notes 2 and 6 to our audited consolidated financial statements and Notes 2 and 6 to our interim condensed consolidated financial statements included elsewhere in this prospectus for additional information.
- (4) See “—Non-GAAP Financial Measures” for definitions of these measures and reconciliations to the most comparable GAAP metric.

## [Table of Contents](#)

### Operating Revenues

(in thousands)	<u>Interim Successor 2019</u>	<u>Interim Successor 2018</u>	<u>Predecessor 2018</u>
	<u>For the nine months ended September 30, 2019</u>	<u>For the period April 11, 2018 through September 30, 2018</u>	<u>For the period January 1, 2018 through April 10, 2018</u>
<b>Operating Revenues</b>			
Scheduled service	\$ 312,493	\$ 147,130	\$ 132,234
Ancillary	89,119	24,870	15,670
Charter service	125,715	72,114	40,663
Other	10,193	4,544	8,885
<b>Total Operating Revenues</b>	<u>\$ 537,520</u>	<u>\$ 248,658</u>	<u>\$ 197,452</u>

Total operating revenues were \$537.5 million for the Interim Successor 2019 period, \$248.7 million for the Interim Successor 2018 period and \$197.5 million for the Predecessor 2018 period. Scheduled service revenue was \$312.5 million for the Interim Successor 2019 period, \$147.1 million for the Interim Successor 2018 period and \$132.2 million for the Predecessor 2018 period. Ancillary revenue was \$89.1 million for the Interim Successor 2019 period, \$24.9 million for the Interim Successor 2018 period and \$15.7 million for the Predecessor 2018 period. Charter service revenue was \$125.7 million for the Interim Successor 2019 period, \$72.1 million for the Interim Successor 2018 period and \$40.7 million for the Predecessor 2018 period. Other revenue was \$10.2 million for the Interim Successor 2019 period, \$4.5 million for the Interim Successor 2018 period and \$8.9 million for the Predecessor 2018 period.

The increase in scheduled service revenue was primarily related to increases in our capacity and departures along with an increase in load factor. Our scheduled service capacity, as measured by ASMs, increased by 30% as a result of additional aircraft in service and increases in the number of seats on board. In the Interim Successor 2019 period, we completed the reconfiguration of substantially all of our fleet to a high-density seating configuration of 183 seats. The increase in capacity led to an increase in our number of scheduled service passengers to 2.7 million from 2.0 million. The increase in scheduled service revenue driven by the increase in passengers was partially offset by a 19% decrease in average scheduled passenger fare from \$142.38 to \$114.75, and a decrease in PRASM of 1.20 cents, or 15%, largely driven by our low-fare pricing strategy.

The increase in ancillary revenue was driven by the unbundling of our services to improve our product segmentation in January 2018, which previously were offered as a component of the base fares. Our focus on ancillary services has increased ancillary revenue on a per passenger basis to \$32.73 from \$20.66.

The increase in our charter service revenue was primarily due to an increase in the number of charter flights and charter block hours for our casino and sports customers and the U.S. Department of Defense.

The decrease in our other revenue was primarily due to lower bookings for our Sun Country Vacations products.



## Table of Contents

### Operating Expenses

(in thousands)	<u>Interim Successor 2019</u>	<u>Interim Successor 2018</u>	<u>Predecessor 2018</u>
	<u>For the nine months ended September 30, 2019</u>	<u>For the period April 11, 2018 through September 30, 2018</u>	<u>For the period January 1, 2018 through April 10, 2018</u>
<b>Operating expenses:</b>			
Aircraft fuel	\$ 127,338	\$ 67,390	\$ 45,790
Salaries, wages and benefits	105,668	57,114	36,964
Aircraft rent	37,959	23,543	28,329
Maintenance	25,041	10,116	9,508
Sales and marketing	27,414	10,465	10,854
Depreciation and amortization	25,371	8,250	2,526
Ground handling	31,009	14,686	8,619
Landing fees and airport rent	33,730	16,139	10,481
Special items, net	6,378	1,757	271
Other operating	51,094	22,889	17,994
<b>Total Operating expenses</b>	<b>\$ 471,002</b>	<b>\$ 232,349</b>	<b>\$ 171,336</b>

*Aircraft Fuel.* Aircraft fuel expense was \$127.3 million for the Interim Successor 2019 period, \$67.4 million Interim Successor 2018 period, and \$45.8 million for the Predecessor 2018 period. The increase was primarily due to an increase in fuel gallons consumed of 21% due to our increased level of operations, as measured by block hours, partially offset by a decrease in average price per gallon of fuel of 3%. Aircraft fuel expense also includes unrealized mark-to-market gains or losses from fuel derivative contracts associated with our economic fuel hedges, the impact of which was that we recognized an unrealized gain of \$6.9 million in the Interim Successor 2019 period, an unrealized gain of \$1.9 million in the Interim Successor 2018 period, and none for the Predecessor 2018 period.

*Salaries, Wages and Benefits.* Salaries, wages and benefits expense was \$105.7 million for the Interim Successor 2019 period, \$57.1 million for the Interim Successor 2018 period, and \$37.0 million for the Predecessor 2018 period. The increase was primarily due to higher costs and increased headcount of our pilots and flight attendants due to contractual rate increases and expanded operations, and higher general and administration staffing along with the full interim impact of the management bonus plan introduced after the acquisition and the stock compensation plan introduced in November 2018. The increase was partially offset by lower overall headcount as a result of outsourcing certain ground operations, which are reflected as an increase in ground handling expenses.

*Aircraft Rent.* Aircraft rent expense was \$38.0 million for the Interim Successor 2019 period, \$23.5 million for the Interim Successor 2018 period and \$28.3 million for the Predecessor 2018 period. Aircraft rent expense decreased primarily due to a change in the composition of our aircraft fleet between leased aircraft (for which expense is recorded under aircraft rent) and purchased aircraft (for which expense is recorded under depreciation and amortization). The decrease was primarily a result of purchasing one aircraft previously on an operating lease, and returning one leased 737-700 aircraft during the Interim Successor 2019 period. Additionally, three aircraft were added to the fleet in the Interim Successor 2019 period under finance leases. The Interim Successor 2019 period and Interim Successor 2018 period were further decreased by the amortization of over-market liabilities, due to over-market liabilities recorded as a result of acquisition accounting for the acquisition by the Apollo Funds. The over-market liabilities are amortized on a straight-line basis over the remaining life of each lease subject to the adjustment at the acquisition date.

*Maintenance.* Maintenance materials and repair costs were \$25.0 million for the Interim Successor 2019 period, \$10.1 million in the Interim Successor 2018 period, and \$9.5 million in the Predecessor 2018 period. This

## [Table of Contents](#)

increase was primarily due to the timing and number of maintenance events, including additional heavy checks and additional component repairs in the Interim Successor 2019 period. The overall increase in maintenance materials expense was partially offset by reduced expenses under our outsourced parts supply agreement and by top-off credits received from lessors for repairs performed by us but related to utilization by the prior lessee. The increase in maintenance expense was also partially offset by the reduction of the maintenance liability (or contra-asset) in the Interim Successor 2019 period and Interim Successor 2018 period, related to a maintenance reserve liability (or contra-asset) recorded as a result of acquisition accounting for the acquisition by the Apollo Funds. The maintenance liability (or contra-asset) is reduced as reimbursable maintenance events are performed and maintenance expense is incurred.

*Sales and Marketing.* Sales and marketing expense was \$27.4 million for the Interim Successor 2019 period, \$10.5 million in the Interim Successor 2018 period and \$10.9 million in the Predecessor 2018 period. The increase was primarily due to an increase in sales that directly drove higher credit card fees and expanded marketing campaigns, partially offset by a decrease in booking fees as a result of a higher proportion of bookings on our redesigned website – our lowest cost distribution channel, and by lower bookings for SCV packages in the Interim Successor 2019 period.

*Depreciation and Amortization.* Depreciation and amortization expense was \$25.4 million for the Interim Successor 2019 period, \$8.3 million in the Interim Successor 2018 period and \$2.5 million in the Predecessor 2018 period. This increase was primarily due to the impact of a change in the composition of the fleet from primarily operating leased aircraft to an increased number of owned aircraft and aircraft operated under finance leases, and the impact of acquisition accounting and the resulting increase to the book value of our assets. We added three aircraft to our fleet under finance leases, purchased one aircraft previously on an operating lease and returned one leased 737-700 aircraft during the Interim Successor 2019 period. In addition, depreciation and amortization was increased due to a definite lived intangible asset recorded as a result of acquisition accounting for the acquisition by the Apollo Funds. The definite lived intangible asset is amortized on a straight-line basis over a useful life of 12 years.

*Ground Handling.* Ground handling expense was \$31.0 million for the Interim Successor 2019 period, \$14.7 million in the Interim Successor 2018 period and \$8.6 million in the Predecessor 2018 period. The increase was due to the increase in departures and additional airports in our route network for both our scheduled service and charter operations. In addition, we fully outsourced MSP ground handling services in May 2018, contributing to a reduction in salaries, wages and benefits, but resulting in higher ground handling expenses.

*Landing Fees and Airport Rent.* Landing fees and airport rent was \$33.7 million for the Interim Successor 2019 period, \$16.1 million in the Interim Successor 2018 period, and \$10.5 million in the Predecessor 2018 period. The increase was due to the increase in departures and additional airports in our route network.

*Special Items, net.* Special items, net was \$6.4 million for the Interim Successor 2019 period, \$1.8 million in the Interim Successor 2018 period, and \$0.3 million in the Predecessor 2018 period. Special items for the Interim Successor 2019 period include expenses of \$7.6 million related to contractual obligations for retired technology, offset by \$1.2 million of proceeds from the sale of unused airport slot rights. Special items for the Interim Successor 2018 period and Predecessor 2018 period related to early-out and employee separation expenses incurred in connection with outsourcing certain operations and other employee initiatives. These efforts were primarily related to airport station, flight attendants and ground handling employees.

*Other Operating Expenses.* Other operating expenses were \$51.1 million for the Interim Successor 2019 period, \$22.9 million for the Interim Successor 2018 period and \$18.0 million for the Predecessor 2018 period, primarily due to our increased level of operations.

## [Table of Contents](#)

### *Non-operating Income (Expense)*

	<u>Interim Successor 2019</u>	<u>Interim Successor 2018</u>	<u>Predecessor 2018</u>
	<u>For the nine months ended September 30, 2019</u>	<u>For the period April 11, 2018 through September 30, 2018</u>	<u>For the period January 1, 2018 through April 10, 2018</u>
(in thousands)			
<b>Non-operating Income (Expense):</b>			
Interest income	\$ 618	\$ 118	\$ 96
Interest expense	(12,700)	(2,823)	(339)
Other, net	(906)	(2,170)	37
<b>Total Non-operating Expenses</b>	<b>\$ (12,988)</b>	<b>\$ (4,875)</b>	<b>\$ (206)</b>

*Interest Income.* Interest income was immaterial for the Interim Successor 2019 period, the Interim Successor 2018 period and the Predecessor 2018 period.

*Interest Expense.* Interest expense was \$12.7 million for the Interim Successor 2019 period, \$2.8 million in the Interim Successor 2018 period and \$0.3 million for the Predecessor 2018 period. The increase was primarily due to finance leases and debt issued to fund the acquisition of new aircraft and spare engines in the Interim Successor 2019 period.

*Other, net.* Other, net was a \$0.9 million loss for the Interim Successor 2019 period, a \$2.2 million loss for the Interim Successor 2018 period and \$37 thousand in income for the Predecessor 2018 period. The decrease was primarily due to miscellaneous income in the Interim Successor 2019 period.

### *Income Taxes*

In the Interim Successor 2019 period, our effective tax rate was 24.8%. Our tax rate can vary depending on the amount of income we earn in each state and the state tax rate applicable to such income. We were taxed as a limited liability company during the Predecessor 2018 period, and therefore, no provision for income tax expense was included on the consolidated statements of operations for that period.

### **Non-GAAP Financial Measures**

We sometimes use information that is derived from the consolidated financial statements, but that is not presented in accordance with GAAP. We believe these non-GAAP measures provide a meaningful comparison of our results to others in the airline industry and our prior year results. Investors should consider these non-GAAP financial measures in addition to, and not as a substitute for, our financial performance measures prepared in accordance with GAAP. Further, our non-GAAP information may be different from the non-GAAP information provided by other companies. We believe certain charges included in our operating expenses on a GAAP basis make it difficult to compare our current period results to prior periods as well as future periods and guidance. The tables below show a reconciliation of non-GAAP financial measures used in this prospectus to the most directly comparable GAAP financial measures.

### ***Adjusted Net Income and Adjusted EBITDAR***

Adjusted Net Income and Adjusted EBITDAR are included as supplemental disclosures because we believe they are useful indicators of our operating performance. Derivations of net income and EBITDAR are well recognized performance measurements in the airline industry that are frequently used by our management, as well as by investors, securities analysts and other interested parties in comparing the operating performance of companies in our industry. Further, we believe Adjusted EBITDAR is useful in evaluating our operating

## Table of Contents

performance compared to our competitors because its calculation isolates the effects of financing in general, the accounting effects of capital spending and acquisitions (primarily aircraft, which may be acquired directly, directly subject to acquisition debt, by finance lease or by operating lease, each of which is presented differently for accounting purposes), and income taxes, which may vary significantly between periods and for different companies for reasons unrelated to overall operating performance.

Adjusted Net Income and Adjusted EBITDAR have limitations as analytical tools. Some of the limitations applicable to these measures include: Adjusted Net Income and Adjusted EBITDAR do not reflect the impact of certain cash charges resulting from matters we consider not to be indicative of our ongoing operations; Adjusted EBITDAR does not reflect our cash expenditures, or future requirements, for capital expenditures or contractual commitments; Adjusted EBITDAR does not reflect changes in, or cash requirements for, our working capital needs; they do not reflect the interest expense, or the cash requirements necessary to service interest or principal payments, on our debt; although depreciation and amortization are non-cash charges, the assets being depreciated and amortized will often have to be replaced in the future, and Adjusted EBITDAR does not reflect any cash requirements for such replacements; and other companies in our industry may calculate Adjusted Net Income and Adjusted EBITDAR differently than we do, limiting each measure's usefulness as a comparative measure. Because of these limitations, Adjusted Net Income and Adjusted EBITDAR should not be considered in isolation or as a substitute for performance measures calculated in accordance with GAAP.

As derivations of Adjusted Net Income and Adjusted EBITDAR are not determined in accordance with GAAP, such measures are susceptible to varying calculations and not all companies calculate the measures in the same manner. As a result, derivations of net income, including Adjusted Net Income and Adjusted EBITDAR, as presented may not be directly comparable to similarly titled measures presented by other companies. In addition, Adjusted EBITDAR should not be viewed as a measure of overall performance since it excludes aircraft rent, which is a normal, recurring cash operating expense that is necessary to operate our business. For the foregoing reasons, each of Adjusted Net Income and Adjusted EBITDAR has significant limitations which affect its use as an indicator of our profitability. Accordingly, you are cautioned not to place undue reliance on this information.

The following tables present the reconciliation of Net Income to Adjusted Net Income for the periods presented below.

	<u>Successor</u>	<u>Successor</u>	<u>Predecessor</u>
	<u>For the year</u>	<u>For the period</u>	<u>For the period</u>
	<u>ended</u>	<u>April 11, 2018</u>	<u>January 1, 2018</u>
	<u>December 31,</u>	<u>through</u>	<u>through</u>
	<u>2019</u>	<u>December 31,</u>	<u>April 10, 2018</u>
	<u></u>	<u>2018</u>	<u></u>
(in thousands)			
<b>Adjusted Net Income reconciliation:</b>			
Net income	\$	\$ (367)	\$ 25,910
Special items, net(1)		(6,706)	271
Gain on asset transactions, net		(811)	—
Stock compensation expense		373	—
Income tax effect of adjusting items, net(2)		1,640	—
<b>Adjusted Net Income</b>	<b>\$</b>	<b>\$ (5,871)</b>	<b>\$ 26,181</b>

- (1) See Note 14 to our audited consolidated financial statements included elsewhere in this prospectus for additional information on the components of special items, net.
- (2) The tax effect of adjusting items, net are calculated at the Company's statutory rate for the applicable period.

[Table of Contents](#)

	<u>Interim Successor</u>	<u>Interim Successor</u>	<u>Predecessor</u>
	<u>For the nine months ended September 30, 2019</u>	<u>For the period April 11, 2018 through September 30, 2018</u>	<u>For the period January 1, 2018 through April 10, 2018</u>
(in thousands)			
<b>Adjusted Net Income reconciliation:</b>			
Net income	\$ 41,054	\$ 8,651	\$ 25,910
Special items, net <sup>(1)</sup>	6,378	1,757	271
Stock compensation expense	1,543	—	—
Loss on asset transactions, net	264	—	—
Other adjustments <sup>(2)</sup>	226	—	—
Income tax effect of adjusting items, net <sup>(3)</sup>	(1,934)	(404)	—
<b>Adjusted Net Income</b>	<b><u>\$ 47,531</u></b>	<b><u>\$ 10,004</u></b>	<b><u>\$ 26,181</u></b>

(1) See Note 13 to our interim condensed consolidated financial statements included elsewhere in this prospectus for additional information on the components of special items, net.

(2) Other adjustments include a loss on a proposed new base of \$226 thousand.

(3) The tax effect of adjusting items, net are calculated at the Company's statutory rate for the applicable period.

[Table of Contents](#)

The following tables present the reconciliation of Net Income to Adjusted EBITDAR for the periods presented below.

	<u>Successor</u>	<u>Successor</u>	<u>Predecessor</u>
	For the year ended December 31, 2019	For the period April 11, 2018 through December 31, 2018	For the period January 1, 2018 through April 10, 2018
<b>Adjusted EBITDAR reconciliation:</b>			
Net income	\$	\$ (367)	\$ 25,910
Special items, net		(6,706)	271
Interest expense		6,060	339
Gain on asset transactions, net		(811)	—
Stock compensation expense		373	—
Interest income		(258)	(96)
Provision for income tax expense		161	—
Depreciation and Amortization		14,405	2,526
Aircraft rent		36,831	28,329
<b>Adjusted EBITDAR</b>	<b>\$</b>	<b>\$ 49,688</b>	<b>\$ 57,279</b>

	<u>Interim Successor</u>	<u>Interim Successor</u>	<u>Predecessor</u>
	For the nine months ended September 30, 2019	For the period April 11, 2018 through September 30, 2018	For the period January 1, 2018 through April 10, 2018
<b>Adjusted EBITDAR reconciliation:</b>			
Net income	\$ 41,054	\$ 8,651	\$ 25,910
Special items, net	6,378	1,757	271
Interest expense	12,700	2,823	339
Stock compensation expense	1,543	—	—
Other adjustments	490	—	—
Interest income	(618)	(118)	(96)
Provision for income tax expense	12,476	2,783	—
Depreciation and Amortization	25,371	8,250	2,526
Aircraft rent	37,959	23,543	28,329
<b>Adjusted EBITDAR</b>	<b>\$ 137,353</b>	<b>\$ 47,689</b>	<b>\$ 57,279</b>

**Liquidity and Capital Resources**

The airline business is capital intensive and our ability to successfully execute our business strategy is largely dependent on the continued availability of capital on attractive terms and our ability to maintain sufficient liquidity. We have historically funded our operations and capital expenditures primarily through cash from operations, proceeds from SCA common stockholders' capital contributions, the issuance of promissory notes and our 2019-01 EETC financing.

Our primary sources of liquidity as of September 30, 2019 include our existing cash and cash equivalents of \$15.8 million and short-term investments of \$5.8 million, our expected cash generated from operations and our \$20.0 million ABL Facility with availability of \$19.65 million. In addition, we had restricted cash of \$15.5 million as of September 30, 2019, which consists of cash received as prepayment for chartered flights that is maintained in separate escrow accounts, from which the restrictions are released once transportation is provided.

## Table of Contents

Our primary sources of liquidity as of December 31, 2019 included our existing cash and equivalents of \$            million and short-term investments of \$            million, our expected cash generated from operations and our \$20.0 million ABL Facility with availability of \$19.65 million. In addition, we had restricted cash of \$            million as of December 31, 2019, which consists of cash received as prepayment for chartered flights that is maintained in separate escrow accounts, from which the restrictions are released once transportation is provided.

On December 13, 2017, Sun Country, Inc. (formerly known as MN Airlines, LLC), our wholly-owned subsidiary (the “Borrower”), entered into an Asset-Based Revolving Credit Agreement (the “ABL Credit Agreement”), which provides for an asset-based revolving credit facility (the “ABL Facility”) in an aggregate committed principal amount of up to \$20.0 million, subject to borrowing base availability. The borrowing base is equal to the sum of (i) 90.0% of the net amount of eligible credit card accounts, (ii) 85.0% of the net amount of eligible receivables, (iii) 75.0% of the net book value of eligible inventory and (iv) 75.0% of the net book value of eligible equipment. The ABL Facility matures on April 11, 2021.

Borrowings under the ABL Credit Agreement bear interest at a rate equal to, at our option, either (a) a LIBOR rate determined by reference to the costs of funds for Eurodollar deposits for the interest period relevant to such borrowing, adjusted for certain additional costs or (b) a base rate, as defined in the ABL Credit Agreement, in each case plus an applicable margin of 4.00% per annum for LIBOR loans or 3.00% per annum for base rate loans. In addition, the Borrower is required to pay a commitment fee to the lenders in respect of the unutilized commitments under the ABL Facility at a rate equal to 0.50% per annum, customary letter of credit fees and customary agency fees. The obligations of the Borrower under the ABL Facility are unconditionally guaranteed by SCA Acquisition, LLC on a limited-recourse basis.

The ABL Facility requires the Borrower to comply with a financial maintenance covenant if the aggregate amount of funded loans and issued letters of credit under the ABL Facility (excluding up to \$3.0 million of undrawn letters of credit under the ABL Facility and letters of credit that are cash collateralized) exceeds 30% of the then-outstanding commitments under the ABL Facility. If the financial maintenance covenant applies, it requires that the Borrower maintain as of the last day of each fiscal quarter a minimum EBITDAR of at least \$87.7 million for the then most recently ended period of four consecutive fiscal quarters. The Borrower was in compliance with the financial maintenance covenant as of December 31, 2019.

The ABL Facility contains certain customary affirmative covenants and negative covenants, including a limitation on the Borrower’s ability to pay dividends on or make distributions in respect of its capital stock or make other restricted payments; provided, however, that the restriction includes several exceptions, including an exception permitting dividends and distributions so long as the Borrower is in compliance with the payment conditions under the ABL Credit Agreement. The Borrower was in compliance with the payment conditions as of December 31, 2019.

The ABL Facility contains certain customary events of default, including relating to a change of control. If an event of default occurs, the lenders under the ABL Facility are entitled to take various actions, including the acceleration of amounts due under the ABL Facility and all actions permitted to be taken by a secured creditor in respect of the collateral securing the ABL Facility.

Our primary uses of liquidity are for operating expenses, capital expenditures, lease rentals and maintenance reserve deposits, debt repayments and working capital requirements. Our single largest capital expenditure requirement relates to the acquisition of aircraft, which we have historically acquired through operating and finance leases and debt.

In December 2019, we arranged for the issuance of Class A, Class B and Class C pass through trust certificates, Series 2019-1, or the “2019-1 EETC,” in an aggregate face amount of \$248.6 million (the “Certificates”) for the purpose of financing or refinancing 13 used aircraft. We plan to use the proceeds from the

## Table of Contents

2019-01 EETC to purchase three aircraft new to our fleet, purchase seven aircraft currently under operating or financing leases with purchase options and refinance three aircraft currently owned and financed under previously existing debt financing. The total appraised value of the 13 aircraft is approximately \$292.5 million. The Certificates were issued to certain institutional investors, and the 2019-1 EETC provides that the face amount of the Certificates will be funded by the purchase price paid by such investors for its Certificates on four funding dates from December 2019 to June 2020. On the first funding date in December 2019, \$102.7 million of the \$248.6 million face amount was funded from payment of the purchase price of the Certificates and placed in escrow. Subsequently in December 2019, we used \$28.3 million of such escrowed funds to finance the purchase of one of the 13 aircraft. In January 2020 we used an additional \$47.3 million of the escrowed funds to refinance three owned aircraft, and we drew an additional \$28.4 million to purchase an additional aircraft. The Certificates bear interest at the following rates per annum: Class A, 4.13% relating to seven of the financed aircraft and 4.25% relating to six of the financed aircraft; Class B, 4.66% relating to seven of the financed aircraft and 4.78% relating to six of the financed aircraft; and Class C, 6.95%. The expected maturity date of the Class A is December 15, 2027, the Class B is December 15, 2025 and the Class C is December 15, 2023.

Although we do not have any additional aircraft purchase or lease commitments in place, we plan to grow the passenger fleet to 50 aircraft by the end of 2023. We may finance additional aircraft through debt financing or finance leases based on market conditions, our prevailing level of liquidity and capital market availability. We may also enter into new operating leases on an opportunistic basis. For further information regarding our future expected capital expenditures, please refer to “—*Contractual Obligations and Commitments*” below.

In addition to funding the acquisition of aircraft, we are required by our aircraft lessors to fund reserves in cash in advance for scheduled maintenance to act as collateral for the benefit of lessors. Qualifying payments that are expected to be recovered from lessors are recorded as lessor maintenance deposits on our consolidated balance sheet. A portion of our cash is therefore unavailable until after we have completed the scheduled maintenance in accordance with the terms of the operating leases. In the Successor 2019 period, Successor 2018 period and Predecessor 2018 period, we made \$ million, \$23.5 million and \$7.6 million, respectively, in maintenance deposit payments to our lessors. As of September 30, 2019, we had \$30 million in recoverable aircraft maintenance deposits on our consolidated balance sheet, of which \$3.0 million is included in accounts receivable because the eligible maintenance had been performed and reimbursement from the lessor is pending. As of December 31, 2019, we had \$ million in recoverable aircraft maintenance deposits on our consolidated balance sheet, of which \$ million is included in accounts receivable because the eligible maintenance had been performed and reimbursement from the lessor is pending.

We believe that our unrestricted cash and cash equivalents, short-term investments and availability under our ABL Facility and the 2019-01 EETC, combined with expected future cash flows from operations, will be sufficient to fund our operations and meet our debt payment obligations for at least the next 12 months. However, we cannot predict what the effect on our business and financial position might be from a change in the competitive environment in which we operate or from events beyond our control, such as volatile fuel prices, economic conditions, weather-related disruptions, the impact of airline bankruptcies, restructurings or consolidations, U.S. military actions or acts of terrorism.

In our cash and cash equivalents and short-term investments portfolio, we invest only in securities that meet our primary investment strategy of maintaining and securing investment principal. The portfolio is managed by reputable firms that adhere to our investment policy that sets forth investment objectives, approved and prohibited investments, and duration and credit quality guidelines. Our policy, and the portfolio managers, are continually reviewed to ensure that the investments are aligned with our strategy.



## [Table of Contents](#)

The tables below present the major indicators of financial condition and liquidity:

(in thousands, except debt-to-capital amounts)	Successor		Change
	As of December 31, 2019	As of December 31, 2018	
Cash and equivalents	\$	\$ 29,600	%
Investments		5,947	%
Long-term debt, net of current portion		49,823	%
Stockholders' equity		235,647	%
Debt-to-capital including aircraft operating and finance lease obligations <sup>(1)</sup>		0.6	%

(1) Calculated using the present value of remaining aircraft lease payments for aircraft that are in our operating fleet as of the balance sheet date. In 2019, following the adoption of the new lease accounting standard, this calculation will be performed utilizing the operating lease obligations as capitalized on our balance sheet. It is not expected to significantly change the ratio. Finance lease obligations were formerly referred to as capital lease obligations prior to our adoption of the new leasing standard on January 1, 2019. See Note 3 to our audited consolidated financial statements included elsewhere in this prospectus for additional information.

## Cash Flows

### *Successor 2019 period and Successor and Predecessor 2018 periods*

The following table presents information regarding our cash flows for the Successor 2019 period and the Successor 2018 and Predecessor 2018 periods:

(in thousands)	Successor		Predecessor
	For the year ended December 31, 2019	For the period April 11, 2018 through December 31, 2018	For the period January 1, 2018 through April 10, 2018
Net cash provided by operating activities	\$	\$ 13,764	\$ 4,583
Net cash used in investing activities		(80,823)	(2,594)
Net cash provided by (used in) financing activities		102,193	(10,680)

### *Cash Provided By Operating Activities.*

For the Successor 2019 Period, net cash provided by operating activities was \$ million, primarily due to net income of \$ million, increased by depreciation and amortization of \$ million related to additional owned and finance leased aircraft, amortization of right-of-use assets of \$ million, and deferred income taxes of \$ million, and an increase in accounts payable of \$ million, partially offset by \$ million in amortization of over-market liabilities related to acquisition accounting, an increase in accounts receivable of \$ million, an increase in lessor maintenance deposits of \$ million, a decrease in operating lease obligations of \$ million and a decrease in air traffic liabilities of \$ million.

For the Successor 2018 Period, net cash provided by operating activities was \$13.8 million, due to a net loss of \$0.4 million, increased by depreciation and amortization of \$14.4 million related to additional owned and finance leased aircraft, and unrealized loss on fuel derivatives of \$12 million due to our fuel price hedging activity, a decrease in accounts receivable of \$20.7 million driven by a one-time recovery of amounts held by our credit card processor, and an increase in air traffic liabilities of \$20.3 million due to increased operations and higher forward bookings, largely offset by \$17.3 million in amortization of over-market liabilities related to acquisition accounting, an increase in lessor maintenance deposits of \$14.1 million, a decrease in accounts payable of \$9.7 million, an increase in prepaid expenses of \$6.1 million and a decrease in other liabilities of \$5.5 million.

## Table of Contents

For the Predecessor 2018 period, net cash provided by operating activities was \$4.6 million, primarily due to net income of \$25.9 million, increased by \$2.5 million related to depreciation and amortization, an increase in accounts payable of \$21.7 million, a decrease in accounts receivable of \$8.1 million, and largely offset by a decrease in air traffic liabilities of \$34.0 million, an increase in receivable due from the predecessor parent of \$7.4 million, an increase in prepaid expenses of \$5.5 million and an increase in lessor maintenance deposits of \$3.1 million.

### *Cash Used In Investing Activities.*

For the Successor 2019 period, net cash used in investing activities was \$ million, primarily due to purchases of property and equipment of \$ million related to investments in our fleet, partially offset by net proceeds of the sale of investments of \$ million due to funding of letters of credit and surety bonds associated with our operations at various airports.

For the Successor 2018 period, net cash used in investing activities was \$80.8 million, primarily due to purchases of property and equipment of \$78.7 million related to investments in our fleet and other assets during 2018 driven by our transformation plan, including the purchase of three aircraft, and net purchases of investments of \$2.1 million.

For the Predecessor 2018 period, net cash used in investing activities was \$2.6 million, primarily due to purchases of property and equipment of \$2.6 million.

### *Cash Provided By Financing Activities.*

For the Successor 2019 period, net cash provided by financing activities was \$ million, primarily due to \$ million of proceeds from equipment notes issued in connection with the 2019-01 EETC financing and \$ million in proceeds from borrowings, partially offset by \$ million of principal payments related to our finance leases and \$ million in debt repayments.

For the Successor 2018 period, net cash provided by financing activities was \$102.2 million, primarily due to SCA common stockholders' capital contributions of \$47.9 million and \$63.3 million in proceeds from borrowings, partially offset by \$3.2 million of principal repayments of capital lease liabilities and \$5.9 million in debt repayments.

For the Predecessor 2018 period, net cash used in financing activities was \$10.7 million, primarily due to cash distributions to SCA common stockholders of \$10.5 million.

### ***Interim Successor 2019 Period and Interim Successor and Predecessor 2018 Periods***

The following table presents information regarding our cash flows for the Interim Successor 2019 period and the Interim Successor 2018 and Interim Predecessor 2018 periods:

	<b>Interim Successor</b>		<b>Predecessor</b>
	<b>For the nine months ended September 30, 2019</b>	<b>For the period April 11, 2018 through September 30, 2018</b>	<b>For the period January 1, 2018 through April 10, 2018</b>
(in thousands)			
Net cash provided by operating activities	\$ 25,654	\$ (7,453)	\$ 4,583
Net cash used in investing activities	(37,001)	(19,725)	(2,594)
Net cash provided by (used in) financing activities	(837)	49,605	(10,680)

## Table of Contents

### *Cash Provided By (Used in) Operating Activities.*

For the Interim Successor 2019 period, net cash provided by operating activities was \$25.7 million primarily due to net income of \$41.1 million, increased by \$25.4 million in depreciation and amortization related to our owned and finance leased aircraft, \$29.0 million in amortization of right-of-use asset and \$12.4 million in deferred income taxes, largely offset by \$10.7 million of amortization of over-market liabilities related to acquisition accounting, an increase of \$14.3 million in lessor maintenance deposits primarily due to an increase in estimated amounts expected to be recovered, a decrease in \$29.7 million in operating lease obligations, a decrease in \$15.2 million in air traffic liabilities due to the timing of forward bookings and a \$9.9 million increase in accounts receivable.

For the Interim Successor 2018 period, net cash used in operating activities was \$7.5 million primarily due to net income of \$8.7 million, increased by \$8.3 million in depreciation and amortization related to our owned and finance leased aircraft, a decrease in \$19.6 million in accounts receivable by a one-time recovery of amounts held by our credit card processor and an increase in air traffic liabilities of \$9.5 million due to increased operations and higher forward bookings, largely offset by \$11.5 million of amortization of over-market liabilities related to acquisition accounting, an increase of \$8.8 million in lessor maintenance deposits, a decrease of \$12.5 million of accounts payable, and a decrease of \$14.9 million in other liabilities.

For the Predecessor 2018 period, net cash provided by operating activities was \$4.6 million, primarily due to net income of \$25.9 million, increased by \$2.5 million related to depreciation and amortization, an increase in accounts payable of \$21.7 million, a decrease in accounts receivable of \$8.1 million and largely offset by a decrease in air traffic liabilities of \$33.8 million, an increase in receivable due from the predecessor parent of \$7.4 million, an increase in prepaid expenses of \$5.5 million and an increase in lessor maintenance deposits of \$3.1 million.

### *Cash Used In Investing Activities.*

For the Interim Successor 2019 period, net cash used in investing activities was \$37.0 million primarily due to \$37.1 million in purchases of property and equipment related to investments in our fleet, which is partially offset by \$0.1 million in net proceeds from the sale of investments.

For the Interim Successor 2018 period, net cash used in investing activities was \$19.7 million during the Interim Successor 2018 period primarily due to \$16.6 million in purchases of property and equipment related to investments in our fleet and \$3.1 million in net purchase of investments.

For the Predecessor 2018 period, net cash used in investing activities was \$2.6 million, primarily due to purchases of property and equipment of \$2.6 million.

### *Cash Provided By Financing Activities.*

For the Interim Successor 2019 period, cash used in financing activities was \$0.8 million period primarily due to \$13.4 million in proceeds from borrowings, largely offset by \$6.7 million in principal repayments related to our finance lease obligations and \$7.5 million in debt repayments.

For the Interim Successor 2018 period, cash provided by financing activities was \$49.6 million during the Interim Successor 2018 period primarily due to \$47.9 million in capital contributions from SCA stockholders and \$4.0 million in proceeds from borrowing, partially offset by \$1.6 million in principal repayments related to our financing lease obligations and \$0.6 million in debt repayments.

For the Predecessor 2018 period, net cash used in financing activities was \$10.7 million, primarily due to cash distributions to SCA common stockholders of \$10.5 million.

## [Table of Contents](#)

### Commitments and Contractual Obligations

We have contractual obligations comprised of aircraft leases and supplemental maintenance reserves, payment of debt and interest and other lease arrangements. The following table includes our contractual obligations as of December 31, 2018 for the periods in which payments are due:

(in thousands)	2019	2020 - 2021	2022 - 2023	Thereafter	Total
Current and long-term debt(1)	\$ 8,606	\$ 17,008	\$ 32,815	\$ —	\$ 58,429
Interest obligations(2)	728	1,440	2,773	—	4,941
Operating lease obligations(3)	56,624	77,667	72,155	54,776	261,222
Capital lease obligations	13,866	28,184	28,184	65,909	136,143
<b>Total</b>	<b>\$ 79,824</b>	<b>\$ 124,299</b>	<b>\$ 135,927</b>	<b>\$ 120,685</b>	<b>\$ 460,735</b>

(1) Includes principal portion only.

(2) Represents interest on current and long-term debt.

(3) Represents non-cancelable contractual payment commitments for aircraft and engines, and includes non-aircraft operating lease obligations.

In addition, our aircraft leases require that we make maintenance reserve payments to cover the cost of major scheduled maintenance for these aircraft. These payments are generally variable as they are based on utilization of the aircraft, including the number of flight hours flown and/or flight departures, and are not included as minimal rental obligations in the table above. We currently estimate our obligation for maintenance reserve payments to be \$279.0 million in total, including \$39.2 million for 2019, \$64.9 million for 2020 and 2021, \$67.6 million for 2022 and 2023 and \$107.3 million thereafter.

### Off Balance Sheet Arrangements

*Indemnities.* Our aircraft, equipment and other leases and certain operating agreements typically contain provisions requiring us, as the lessee, to indemnify the other parties to those agreements, including certain of those parties' related persons, against virtually any liabilities that might arise from the use or operation of the aircraft or such other equipment. We believe that our insurance would cover most of our exposure to liabilities and related indemnities associated with the leases described above.

Certain of our aircraft and other financing transactions also include provisions that require us to make payments to preserve an expected economic return to the lenders if that economic return is diminished due to certain changes in law or regulations. In certain of these financing transactions and other agreements, we also bear the risk of certain changes in tax laws that would subject payments to non-U.S. entities to withholding taxes.

Certain of these indemnities survive the length of the related lease. We cannot reasonably estimate our potential future payments under the indemnities and related provisions described above because we cannot predict when and under what circumstances these provisions may be triggered and the amount that would be payable if the provisions were triggered because the amounts would be based on facts and circumstances existing at such time.

*Pass-Through Trusts.* We have equipment notes outstanding issued under the 2019-01 EETC. Generally, the structure of the EETC financings consists of pass-through trusts created by us to issue pass-through certificates, which represent fractional undivided interests in the respective pass-through trusts and are not obligations of Sun Country. The proceeds of the issuance of the pass-through certificates are used to purchase equipment notes which are issued by us and secured by our aircraft. The payment obligations under the equipment notes are those of Sun Country. Proceeds received from the sale of pass-through certificates may be initially held by a depository in escrow for the benefit of the certificate holders until we issue equipment notes to the trust, which purchases such notes with a portion of the escrowed funds. These escrowed funds are not guaranteed by us and are not reported as debt on our consolidated balance sheets because the proceeds held by the depository are not our

assets. We record the debt obligation upon issuance of the equipment notes rather than upon the initial issuance of the pass-through certificates.

*Fuel Consortia.* We currently participate in fuel consortia at MSP, Las Vegas International Airport, Dallas-Fort Worth International Airport, San Diego International Airport and Southwest Florida International Airport and we expect to expand our participation with other airlines in fuel consortia and fuel committees at our airports where economically beneficial. These agreements generally include cost-sharing provisions and environmental indemnities that are generally joint and several among the participating airlines. Any costs (including remediation and spill response costs) incurred by such fuel consortia above insured amounts, where applicable, could also have an adverse impact on our business, results of operations and financial condition. Consortia that are governed by interline agreements are either (i) not variable interest entities because they are not legal entities or (ii) are variable interest entities but the Company is not deemed the primary beneficiary. Therefore, these agreements are not reflected on our consolidated balance sheets. Our participation generally represents a small percentage of the overall fuel consortia interests, so our exposure would be limited to our proportional share of the fuel consortia's overall costs; therefore, no liabilities related to any guarantees were recorded at the time the indirect guarantees were made. We may withdraw from the agreements at any time, subject to compliance with certain provisions of the agreements.

We have no other off-balance sheet arrangements.

### **Critical Accounting Policies and Estimates**

Our financial position and results of operations are affected by significant judgments and estimates made by management in accordance with GAAP. These estimates are based on historical experience and varying assumptions and conditions. Consequently, actual results could differ from estimates. Critical accounting policies and estimates are defined as those policies that reflect significant judgments or estimates about matters both inherently uncertain and material to our financial condition or results of operations. For a detailed discussion of our significant accounting policies, see Note 3 to our audited consolidated financial statements and Notes 1 and 3 to our interim consolidated financial statements included elsewhere in this prospectus for additional information.

#### ***Revenue Recognition***

*Scheduled Service and Ancillary Revenue.* We generate the majority of our revenue from sales of passenger tickets and ancillary services along with charter sales. We initially defer ticket sales as an air traffic liability and recognize revenue when the passenger flight occurs. An unused nonrefundable ticket expires at the date of scheduled travel. Customers may elect to change their itinerary prior to departure. The amount remaining after deducting any applicable change fee is a credit that can currently be used towards the purchase of a new ticket for up to 12 months after the date of the change. The recorded value of the credit is calculated based on the original value less the change fee.

We estimate and record breakage for unused tickets (where the ticket is not used and not extended, the customer is deemed a "no show" and the ticket is no longer valid) and travel credits we expect will expire unused. Estimating the amount of breakage involves subjectivity and judgment. These estimates are based on our historical experience of no-show tickets and travel credits and consider other facts, such as recent aging trends, program changes and modifications that could affect the ultimate usage patterns of tickets and travel credits.

We estimate and record breakage for travel credits we expect will expire unused. Estimating the amount of breakage involves subjectivity and judgment. These estimates are based on our historical experience of unused travel credits and consider other factors, such as recent aging trends, program changes and modifications that could affect the ultimate usage patterns of travel credits.

Effective January 1, 2019, we adopted Accounting Standards Update ("ASU") 2014-09, *Revenue from Contracts with Customers (Topic 606)* (the New Revenue Standard). The adoption of the New Revenue Standard

## [Table of Contents](#)

impacts the timing of recognition of certain fees and changes our accounting for outstanding loyalty points earned through travel by Sun Country Reward loyalty program members. There is no change in accounting for loyalty points transferred to our co-branded card partner as these have historically been reported in accordance with the New Revenue Standard. Through December 31, 2018, we used the incremental cost method to account for the portion of the loyalty program liability related to points earned through travel, which were valued based on the estimated incremental cost of carrying one additional passenger. The New Revenue Standard required us to change to the deferred revenue method and apply a relative standalone selling price approach whereby a portion of each passenger ticket sale attributable to loyalty points earned is deferred and recognized in passenger revenue upon future redemption.

Upon adoption of the New Revenue Standard, we reclassified certain ancillary revenues from Other Revenue to Passenger Revenue. In addition, certain fees previously recognized when incurred by the customer are deferred and recognized as revenue when passenger travel is provided.

We recognize ancillary revenue for baggage fees, seat selection fees, and on-board sales when the associated flight occurs. Prior to adoption of the New Revenue Standard, we recognized change fees as the transactions occurred. Under the New Revenue Standard, change fees are deferred and recognized when the passenger travel is provided. Fees sold in advance of the flight date are initially recorded as an air traffic liability. Ancillary revenue also includes services not directly related to providing transportation, such as revenue from our Sun Country Rewards program, as described below in “—*Frequent Flyer Program*.”

*Charter Service Revenue.* Charter revenue is recognized at the time of departure when transportation is provided.

*Frequent Flyer Program.* The Sun Country Rewards program provides frequent flyer rewards to program members based on accumulated reward credits. Reward credits are earned as a result of travel and purchases using our co-branded credit card. The program terms include expiration of reward credits after 36 months from the date they were earned, except members who are holders of the Sun Country co-branded credit card are not subject to the expiration terms. For reward credits earned under the Sun Country Rewards program, we have an obligation to provide future services when these reward credits are redeemed.

With respect to rewards earned as a result of travel, prior to adoption of the New Revenue Standard we recognized a loyalty program liability and a corresponding sales and marketing expense as the reward credits were earned and redeemed by loyalty program members, representing the incremental cost associated with the obligation to provide travel in the future. The incremental cost for reward credits to be redeemed on our flights was estimated based on historical costs, which include the cost of aircraft fuel, insurance, security, ticketing and reservation costs. We adjusted our liability for outstanding points to fair value in connection with acquisition accounting and in the Successor 2018 period. Upon adoption of the New Revenue Standard, we adjusted the liability to fair value as of the adoption date and we now account for the earning and redemption of reward credits based on the deferred revenue method and the relative standalone selling price including expected breakage.

We estimate breakage for reward credits that are not likely to be redeemed. A change in assumptions as to the period over which reward credits are expected to be redeemed, the actual redemption activity or the estimated fair value of reward credits expected to be redeemed could have an impact on revenues in the year in which the change occurs and in future years. Current and future changes to the reward credit expiration policy or the program rules and program redemption opportunities may result in material changes to the loyalty program liability balance, as well as revenue recognized from the program.

*Co-Brand Credit Card Program.* Our co-branded credit card with First Bank, a division of First National Bank of Omaha, provides members with benefits which include a 50% discount on seat selection and bag fees (for the first checked bag), priority boarding, free premium drink during flight, and protection from their points expiring.

## [Table of Contents](#)

We account for funds received for the advertising and marketing of the co-branded credit card and delivery of loyalty program reward credits as a multiple-deliverable arrangement. Funds received are allocated based on relative selling price. For the selling price of travel awards, we considered the terms for redemption under the Sun Country Rewards program that determine how reward credits are applied to purchase Sun Country services.

Prior to adoption of the New Revenue Standard, we applied a multiple element approach, and, in connection with our adoption of the New Revenue Standard, we updated the relative standalone selling prices of the marketing, passenger benefits and future transportation elements. Consideration allocated to reward credits is deferred and recognized as passenger revenue as reward credit points are redeemed for travel. Consideration allocated to the marketing and advertising element is earned as the co-branded card is used and recorded in Other revenue.

### *Aircraft Maintenance*

Under our aircraft operating lease agreements and FAA operating regulations, we are obligated to perform all required maintenance activities on our fleet, including component repairs, scheduled airframe checks and major engine restoration events. Significant maintenance events include periodic airframe checks, engine overhauls, limited life parts replacement and overhauls to major components. Certain maintenance functions are performed by third-party specialists under contracts that require payment based on a utilization measure such as flight hours.

For owned aircraft and engines, we account for significant maintenance under the built-in overhaul method. Under this method, the cost of airframes and engines (upon which the planned significant maintenance activity is performed) is segregated into those costs that are to be depreciated over the expected useful life of the airframes and engines and those that represent the estimated cost of the next planned significant maintenance activity. Therefore, the estimated cost of the first planned significant maintenance activity is separated from the cost of the remainder of the airframes and engines and amortized to the date of the initial planned significant maintenance activity. The cost of that first planned major maintenance activity is then capitalized and amortized to the next occurrence of the planned major maintenance activity, at which time the process is repeated. The estimated period until the next planned significant maintenance event is estimated based on assumptions including estimated cycles, hours, and months, required maintenance intervals, and the age and condition of related parts.

These assumptions may change based on changes in the utilization of our aircraft, changes in government regulations and suggested manufacturer maintenance intervals. In addition, these assumptions can be affected by unplanned incidents that could damage an airframe, engine or major component to a level that would require a significant maintenance event prior to a scheduled maintenance event. To the extent the estimated timing of the next maintenance event is extended or shortened, the related depreciation period would be lengthened or shortened prospectively, resulting in lower depreciation expense over a longer period or higher depreciation expense over a shorter period, respectively.

For leased aircraft, we expense maintenance as incurred. Routine cost for maintaining the airframes and engines and line maintenance are charged to maintenance expense as performed.

*Maintenance Reserves.* Our aircraft lease agreements provide that we pay maintenance reserves to aircraft lessors to be held as collateral in advance of our required performance of significant maintenance events. Our lease agreements with maintenance reserve requirements provide that maintenance reserves are reimbursable to us upon completion of the maintenance event in an amount equal to the lesser of either (1) the amount of the maintenance reserve held by the lessor associated with the specific maintenance event or (2) the qualifying costs related to the specific maintenance event. Some portions of the maintenance reserve payments are fixed contractual amounts, while others are based on a utilization measure, such as actual flight hours or cycles.

At lease inception and at each annual balance sheet date, we assess whether the maintenance reserve payments required by the lease agreements are substantively and contractually related to the maintenance of the

## [Table of Contents](#)

leased asset. Maintenance reserves expected to be recovered from lessors are reflected as lessor maintenance deposits on the consolidated balance sheets. When it is not probable that we will recover amounts paid, such amounts are expensed as a component of aircraft rent expense in our consolidated statements of operations.

We make various assumptions to determine the recoverability of maintenance reserves, such as the estimated time between the maintenance events, the date the aircraft is due to be returned to the lessor and the number of flight hours and cycles the aircraft is estimated to be utilized before it is returned to the lessor. Changes in estimates are accounted for on a cumulative catch-up basis.

### ***Goodwill and Indefinite-Lived Intangible Assets***

We apply a fair value based impairment test to the carrying value of goodwill and indefinite-lived intangible assets at least annually, or more frequently if certain events or circumstances indicate that an impairment loss may have been incurred. We assess the value of goodwill and indefinite-lived assets under either a qualitative or, if necessary, a quantitative approach.

Under a qualitative approach, we consider various market factors, including applicable key assumptions listed below. These factors are analyzed to determine if events and circumstances have affected the fair value of goodwill and indefinite-lived intangible assets. Factors which could indicate an impairment include, but are not limited to, (1) negative trends in our market capitalization, (2) reduced profitability resulting from lower passenger mile yields or higher input costs (primarily related to fuel and employees), (3) lower passenger demand as a result of weakened U.S. and global economies, (4) interruption to our operations due to a prolonged employee strike, terrorist attack or other reasons, (5) changes to the regulatory environment (e.g., diminished slot access), (6) competitive changes by other airlines and (7) strategic changes to our operations leading to diminished utilization of the intangible assets.

If our qualitative assessment indicates that it is more likely than not that goodwill or indefinite-lived intangible assets are impaired, we must perform a quantitative test that compares the fair value of the asset with its carrying amount.

In the event that we need to apply a quantitative approach for evaluating goodwill for impairment, we estimate the fair value of the reporting unit by considering both market capitalization and projected discounted future cash flows (an income approach). Key assumptions and estimates made in estimating the fair value include: (i) a projection of revenues, expenses and cash flows; (ii) terminal period revenue growth and cash flows; (iii) an estimated weighted average cost of capital; (iv) an assumed discount rate depending on the asset; (v) a tax rate; and (vi) market prices for comparable assets. In the event that we need to apply a quantitative approach for evaluating our indefinite-lived intangible assets for impairment, we estimate the fair value based on the relief from royalty method for the Sun Country trade name. The relief from royalty methodology values the asset based on the assumed royalty rate the business would pay to achieve the revenues associated with that asset if the asset was not owned.

For either goodwill or indefinite-lived assets, if the carrying value of the asset exceeds its fair value calculated using the quantitative approach, an impairment charge is recorded for the difference in fair value and carrying value.

We believe these assumptions are consistent with those a hypothetical market participant would use given circumstances that were present at the time the estimates were made.

### ***Long-Lived Assets***

In accounting for long-lived assets, we make estimates about the expected useful lives, projected residual values and the potential for impairment. In estimating the useful lives and residual values of our aircraft, we have relied upon actual industry experience with the same or similar aircraft types and our anticipated utilization of the



## [Table of Contents](#)

aircraft. Changing market prices of new and used aircraft, government regulations and changes in our maintenance program or operations could result in changes to these estimates. Our long-lived assets are evaluated for impairment when events and circumstances indicate the assets may be impaired. Indicators may include operating or cash flow losses, significant decreases in market value, or changes in technology.

### ***Management Options Valuation***

Subsequent to granting options to certain members of our management team, the fair values of the shares of SCA common stock underlying our options were determined on each grant date by our board of directors with input from management and with the assistance of a third-party valuation advisor. In order to determine the fair value, our board of directors considered, among other things, contemporaneous valuations of our SCA common stock prepared by the unrelated third-party valuation firm in accordance with the guidance provided by the American Institute of Certified Public Accountants 2013 Practice Aid, *Valuation of Privately-Held-Company Equity Securities Issued as Compensation*, or the Practice Aid. Given the absence of a public trading market of our capital stock, the assumptions used to determine the estimated fair value of our SCA common stock was based on a number of objective and subjective factors, including:

- our stage of development and business strategy;
- our business, financial condition and results of operations, including related industry trends affecting our operations;
- the likelihood of achieving a liquidity event, such as an initial public offering or sale of our company, given prevailing market conditions;
- the lack of marketability of our SCA common stock;
- the market performance of comparable publicly traded companies; and
- U.S. and global economic and capital market conditions and outlook.

The fair value of the time-based stock options granted during 2018 and 2019 was estimated using the Black-Scholes option-pricing model with expected term based on vesting criteria and time to expiration. The expected volatility was based on historical volatility of stock prices and assets of a public company peer group. The risk-free interest rate was based on the implied risk-free rate using the expected term and yields of U.S Treasury stock and S&P bond yields.

The fair value of the performance-based stock options granted during 2018 and 2019 was estimated by simulating the future stock price using geometric brownian motion and risk-free rate of return at intervals specified in the grant agreement. The number of shares vested and future price at each interval were recorded for each simulation and then multiplied together and discounted to present value at the risk-free rate of return.

Our enterprise value was estimated by using market multiples and a discounted cash flow analysis based on plans and estimates used by management to manage the business. We evaluated comparable publicly traded companies in the airline industry. We used market multiples after considering the risks associated with the strategic shift in our business, the availability of financing, labor relations and an intensely competitive industry. The estimated value was then discounted by a non-marketability factor due to the fact that stockholders of private companies do not have access to trading markets similar to those available to stockholders of public companies, which impacts liquidity.

The determination of the fair values of our non-public shares of SCA common stock and stock-based awards are based on estimates and forecasts described above that may not reflect actual market results. These estimates and forecasts require us to make judgments that are highly complex and subjective. Additionally, past valuations relied on reference to other companies for the determination of certain inputs. After completion of this offering, future stock-based grant values will be based on quoted market prices.

## Quantitative and Qualitative Disclosure About Market Risk

We are subject to market risks in the ordinary course of our business. These risks include commodity price risk, specifically with respect to aircraft fuel, as well as interest rate risk. The adverse effects of changes in these markets could pose a potential loss as discussed below. The sensitivity analysis provided does not consider the effects that such adverse changes may have on overall economic activity, nor does it consider additional actions we may take to mitigate our exposure to such changes. Actual results may differ.

*Aircraft Fuel.* Unexpected pricing changes of aircraft fuel could have a material adverse effect on our business, results of operations and financial condition. To hedge the economic risk associated with volatile aircraft fuel prices, we periodically enter into fuel collars, which allows us to reduce the overall cost of hedging, but may prevent us from participating in the benefit of downward price movements. In the past, we have also entered into fuel option and swap contracts. As of December 31, 2019, we had fuel collar hedges in place for approximately 61% of our projected fuel requirements for scheduled service operations in 2020, with all of our then existing options expected to be exercised or expire by the end of 2021. We do not hold or issue option or swap contracts for trading purposes. We expect to continue to enter into these types of contracts prospectively, although significant changes in market conditions could affect our decisions. Based on our 2020 forecasted fuel consumption as of December 31, 2019, we estimate that a one cent per gallon increase in average aircraft fuel price would increase our 2020 annual aircraft fuel expense by \$        million, excluding any impact associated with fuel derivative instruments held.

*Interest Rates.* We have exposure to market risk associated with changes in interest rates related to the interest income from our short-term investment portfolio. A change in market interest rates would impact interest income earned on our cash and equivalents and short-term investments. Assuming our cash and equivalents and short-term investments remain at December 31, 2019 balances, a 100 basis point decrease in interest rates would result in a corresponding decrease in interest income of approximately \$        million during 2020.

## JOBS Act Accounting Election

In April 2012, the JOBS Act was signed into law. The JOBS Act contains provisions that, among other things, reduce certain reporting requirements for an “emerging growth company.” We have elected to use this extended transition period for complying with new or revised accounting standards that have different effective dates for public and private companies until the earlier of the date that we (i) are no longer an emerging growth company or (ii) affirmatively and irrevocably opt out of the extended transition period provided in the JOBS Act. As a result, our audited financial statements may not be comparable to companies that comply with the new or revised accounting pronouncements as of public company effective dates.

We have chosen to rely on the other exemptions and reduced reporting requirements provided by the JOBS Act. Subject to certain conditions set forth in the JOBS Act, as an “emerging growth company” we are not required to, among other things, (i) provide an auditor’s attestation report on our system of internal control over financial reporting pursuant to Section 404 of the Sarbanes-Oxley Act, (ii) provide all of the compensation disclosure that may be required of non-emerging growth public companies, (iii) comply with any requirement that may be adopted by the Public Company Accounting Oversight Board (United States) regarding mandatory audit firm rotation or a supplement to the auditor’s report providing additional information about the audit and the consolidated financial statements (auditor discussion and analysis) and (iv) disclose certain executive compensation-related items, such as the correlation between executive compensation and performance and comparisons of the chief executive officer’s compensation to median employee compensation. We may remain an “emerging growth company” until the last day of the fiscal year following the fifth anniversary of the completion of this offering. However, if certain events occur prior to the end of such five-year period, including if we become a “large accelerated filer,” our annual gross revenue equals or exceeds \$1.07 billion or we issue more than \$1.0 billion of non-convertible debt in any three-year period, we will cease to be an “emerging growth company” prior to the end of such five-year period.

**Recent Accounting Pronouncements**

See Note 3 to our audited consolidated financial statements and Note 1 to our interim consolidated financial statements included elsewhere in this prospectus for recently issued accounting pronouncements adopted in 2018 and 2019 or not yet adopted as of the date of this prospectus.

## INDUSTRY

The U.S. airline industry has consolidated significantly over the last two decades. In 2000, the four largest U.S. carriers controlled approximately 59% of the domestic market, based on number of available seats, and there were 11 additional airlines of significant size competing in a fragmented market. As a result of the consolidation in the sector, the four largest U.S. carriers control approximately 78% of the market as of 2018 and there are seven additional airlines of significant size competing in what is now a more consolidated market. This shift has been principally driven by a number of business combinations which have reshaped the domestic landscape: Delta Air Lines combined with Northwest Airlines in 2008, United Airlines combined with Continental Airlines in 2010, Southwest Airlines acquired AirTran Airlines in 2010, American Airlines (following its acquisition of Trans World Airlines in 2001) combined with US Airways in 2013 (following its combination with America West Airlines in 2005) and Alaska Airlines acquired Virgin America in 2016. Consolidation has benefitted the U.S. airline sector, which has seen RASM increase from \$11.12 cents in 2000 to \$14.81 cents in 2018, while according to BTS, the average domestic air fare has climbed from \$156 to \$168 over the same period. As a result, the U.S. airline industry has recorded \$82 billion of cumulative net income from 2008 through 2018.

U.S. airlines can broadly be divided into three categories: legacy network airlines; LCCs; and ULCCs. While each major airline based in the United States generally competes with each other for airline passengers traveling on the routes they serve, particularly customers traveling in economy or similar classes of service, these categories identify the operating strategies of these airlines.

The legacy network airlines, including United Airlines, Delta Air Lines and American Airlines, serve a large business travel customer base and offer scheduled flights to most large cities within the United States and abroad (directly or through membership in one of the global airline alliances) and also serve numerous smaller cities. These airlines operate predominantly through a “hub-and-spoke” network route system. This system concentrates most of an airline’s operations in a limited number of hub cities, serving other destinations in the system by providing one-stop or connecting service through hub airports to end destinations on the spokes. Such an arrangement enables travelers to fly from a given point of origin to more destinations without switching airlines. While hub-and-spoke systems result in low marginal costs for each incremental passenger, they also result in high fixed costs. The unit costs incurred by legacy network airlines to provide the gates, airport ground operations and maintenance facilities needed to support a hub-and-spoke operation are generally higher than those of the point-to-point network typically operated by LCCs and ULCCs. Aircraft schedules at legacy network airlines also tend to be inefficient to meet the requirements of connecting banks of flights in hubs, resulting in lower aircraft and crew utilization. Serving a large number of markets of different sizes requires the legacy network airlines to have multiple fleets with multiple aircraft types along with the related complexities and additional costs for crew scheduling, crew training and maintenance. As a result, legacy network airlines typically have higher cost structures than LCCs and ULCCs due to, among other things, higher labor costs, flight crew and aircraft scheduling inefficiencies, concentration of operations in higher cost airports, and the offering of multiple classes of services, including multiple premium classes of service.

In contrast, the LCC model focuses on operating a more simplified operation, providing point-to-point service without the high fixed costs required for a hub-and-spoke system. The lower cost structure of LCCs enables them to offer flights to and from many of the same markets as the major airlines at lower fares, though LCCs sometimes serve major markets through secondary, lower-cost airports in the same region. LCCs typically fly direct, point-to-point flights, which enables improved aircraft and crew scheduling efficiency. Many LCCs provide only a single class of service, thereby avoiding the incremental cost of offering premium-class services. Finally, LCCs tend to operate fleets with very few aircraft families in order to maximize the utilization of flight crews across the fleet, to improve aircraft scheduling flexibility and to minimize inventory and aircraft maintenance costs. The major U.S. based airlines that define themselves as LCCs include Southwest Airlines and JetBlue Airways.

The ULCC model, which was pioneered by Ryanair in Europe and Spirit Airlines in the United States, was built on the LCC model, but combined with a focus on increased aircraft utilization, increased seat density and

## [Table of Contents](#)

the unbundling of revenue sources aside from ticket prices with multiple products and services offered for purchase by the customer at additional cost. ULCCs have lower unit costs than the legacy network carriers or the LCCs. In addition, ULCCs are capable of driving significant increases in passenger volumes as a result of their low base fares. The major U.S. based airlines that define themselves as ULCCs include Spirit Airlines, Allegiant Travel Company and Frontier Airlines.

Within the broader U.S. charter market, which includes business jets, widebody and narrowbody charters, Sun Country exclusively focuses on the narrowbody segment. The narrowbody charter segment has experienced steady growth over the recent years posting an estimated 6.1% CAGR over the 2013-2018 period and reaching an approximately \$1.2 billion market size as of 2018, based on management estimates.

On the demand side, key customer segments within the U.S. narrowbody charter market include casinos and tour groups, the U.S. Department of Defense, sports teams (both professional and college teams) and other government customers. As of 2018, we had strong market positions in the casinos and tours customer segments, the U.S. Department of Defense and college sports customer segments with an estimated market share of approximately 33%, 29% and 18%, respectively. These customer segments are primarily comprised of large, high-budget organizations with recurring (in some cases even long-term contracted) and resilient spend. The typical contract generally provides for the customer to pay a fixed charter fee insurance, landing fees, navigation fees and most other operational fees and cost. Fuel costs are contractually passed through to the customer, enhancing margins and removing commodity risk from the operators.

On the supply side, the market is fragmented and primarily served by pure play charter operators that typically operate small fleets and serve relatively small networks across the country. The reduced fleet size and network scale of pure play charter operators results in limited reserve aircraft to react to unexpected problems and schedule changes. Larger, high-budget and enduring charter customers primarily seek operational reliability and aircraft and crew availability to serve their planned and on-demand needs. In light of these specific needs, the size, scale, and reach of the network are key strategic advantages to compete in the charter market.

We believe that Sun Country represents a new breed of hybrid air carrier that shares certain characteristics with Allegiant Travel Company and Southwest Airlines. Sun Country's model includes many of the low cost structure characteristics of ULCCs, such as an unbundled product, point-to-point service and a single aircraft family fleet, which allow us to maintain a cost base comparable to ULCCs. However, our product includes greater legroom, free beverages, in-flight entertainment and in-seat power that are consistent with the more elevated product of LCCs. Furthermore, we fly a flexible "peak demand" network that allows us to generate higher TRASM than ULCCs while maintaining lower CASM ex than LCCs. The only air carrier in the United States that flies a similar flexible network is Allegiant Travel Company, but Allegiant flies to different markets than we do with a lesser product, smaller charter business and limited ticket distribution network through its website (closed distribution).

## BUSINESS

### Overview

Sun Country Airlines is a Minnesota-based high-growth, low-cost air carrier focused on serving leisure passengers on flights throughout the United States and to destinations in Mexico, Central America, the Caribbean and Canada. We operate an agile network that includes both our core scheduled service business and our synergistic and profitable charter business. Our model dynamically deploys shared aircraft and flight crews across our service lines with the objective of generating higher returns and margins. We optimize capacity allocation by market, time of year, day of week and line of business by shifting flying to markets during periods of high demand and away from markets during periods of low demand with far greater frequency than other airlines other than Allegiant Travel Company. However, unlike us, Allegiant flies to different markets than we do with a basic product, smaller charter business and limited ticket distribution network through its website. Our model includes many of the low-cost structure characteristics of ULCCs (which include Allegiant Travel Company, Spirit Airlines and Frontier Airlines), such as an unbundled product, point-to-point service and a single-family fleet of Boeing 737-NG aircraft, which allow us to maintain a cost base comparable to these ULCCs. However, we offer an elevated product that we believe is superior to the ULCCs and consistent with that of LCCs (which include Southwest Airlines and JetBlue Airways). For example, our product includes more legroom than ULCCs, free beverages, in-flight entertainment and in-seat power, none of which are offered by the ULCCs. The combination of our agile “peak demand” network with our elevated consumer product allows us to generate higher TRASM than ULCCs while maintaining lower CASM ex unit costs than LCCs. As a result of our complementary scheduled service, charter and future cargo businesses, agile “peak demand” network and low-cost structure similar to ULCCs and elevated consumer product similar to LCCs, we believe that Sun Country Airlines represents a new breed of hybrid air carrier.

In April 2018, we were acquired by the Apollo Funds. Since the acquisition, we have transformed our business under a new management team of seasoned professionals who have a strong combination of low-cost and legacy network airline experience. We have redesigned our network to focus our flying on peak demand opportunities at both our Minneapolis/St. Paul, or MSP, hub and our growing network of non-MSP point-to-point markets, which has supported a 43% increase in passengers from 2017 to 2019. We have greatly expanded our ancillary products and services, increasing average ancillary revenue per scheduled service passenger by over % from 2017 to 2019. Since 2017, management has taken actions to reduce our cost basis by approximately \$34 million on an annual basis, contributing to a reduction in CASM ex of over % between 2017 and 2019. We have invested over \$115 million in new aircraft, new interiors, information technology systems and other growth-oriented capital expenditure projects since the beginning of 2017. In June 2019, we introduced a new website and replaced our reservation and distribution system with the *Navitaire* system, which has lowered our selling costs, increased the proportion of our bookings that are made directly through our website and simplified the process of buying tickets and changing flight details post-purchase. We believe that these investments have positioned us to profitably grow our business in the long term and that our period of heavy investment in transformative capital spending is behind us for the foreseeable future.

Our network transformation has focused on increasing routes flown while allocating our assets to the most profitable lines of flying. We concentrate scheduled service trips during the highest yielding months of the year and days of the week, and we allocate aircraft to our charter service when it is more profitable to do so. As a result, in 2019 only 3% of our routes were daily year-round. Although this scheduling approach results in lower fleet utilization, it generates higher TRASM than our ULCC competitors. In addition to network changes, we have invested in new aircraft interiors, including the removal of a legacy first class section and the replacement of older seats on all of our 737-800 aircraft with new comfortable reclining seats. We have increased the average seat count on our 737-800s from 162 to 186 while still offering an average pitch, which is defined as the distance from the back of a seat to the back of the seat directly in front of it, of approximately 31 inches, which is comparable legroom to Southwest Airlines and greater legroom than all of our ULCC competitors. We have also installed in-seat power and provide complimentary in-flight entertainment streamed to passengers’ devices, features that are comparable to those offered by our LCC competitors and that are not offered by any of our

## Table of Contents

ULCC competitors, providing our passengers with a preferred onboard experience. As part of our transformation, we have greatly increased our level of ancillary product sales, which consist of baggage fees, seat assignment fees and other fees. Our dynamic scheduling strategy, quality product and focus on ancillary revenue generation have allowed us to produce unit revenue, as measured by TRASM, of \_\_\_\_\_ cents for the year ended December 31, 2019, which is comparable to LCCs and higher than ULCCs.

Our business transformation has also focused heavily on unit cost reduction. We have achieved cost savings by renegotiating certain key contracts and agreements, outsourcing certain functions to third-party service providers, reducing the cost of our fleet through more efficient aircraft sourcing and financing, staffing efficiencies and other cost-saving initiatives. As a result of these savings and the seat densification of our aircraft, our CASM ex has decreased from 7.79 cents for the year ended December 31, 2017 to \_\_\_\_\_ cents for the year ended December 31, 2019. Our CASM ex for the year ended December 31, 2019 is comparable to ULCCs. We believe that we are well-positioned to continue reducing our unit costs as we grow through ongoing strategic initiatives and as we realize greater economies of scale. In addition, leisure travel was less adversely impacted by the economic downturn in 2008 than business travel. As a result, we believe that low cost, leisure focused business models similar to ours have been more resilient during economic downturns compared to business models adopted by legacy network airlines.

Our transformation has resulted in rapid growth and significant improvements to our financial results. From 2017 to 2019, our average fleet count has increased from 23.4 to 28.4 aircraft, our available seat miles have increased by approximately 35% and our revenue has increased by approximately \_\_\_\_%. In 2019, our total revenue was approximately \$ \_\_\_\_\_ million, our net income was approximately \$ \_\_\_\_\_ million, our Adjusted Net Income was approximately \$ \_\_\_\_\_ million, our Adjusted EBITDAR was approximately \$ \_\_\_\_\_ million and we had positive free cash flow, which we define as operating cash flow minus capital expenditures.

### ***Our New Air Cargo Services Contract with Amazon***

On December 13, 2019, we signed a six-year contract (with two, two-year extension options, for a maximum term of 10 years) with Amazon to provide them with air cargo services. Flying under the ATSA is expected to begin in the second quarter of 2020 and be fully ramped up by the fourth quarter of 2020, at which point Amazon will have up to 10 Boeing 737-800 cargo aircraft flown by Sun Country. We expect this new business will enable us to leverage certain assets, capabilities and fixed costs to enhance profitability and promote growth. For example, we believe that by deploying pilots across each of our business lines we can increase the efficiency of our operations. Moreover, our air cargo services business addresses rapidly growing demand for e-commerce air cargo solutions, which we believe represents a significant opportunity for future growth.

### **Our Competitive Strengths**

We believe that the following key strengths allow us to compete successfully within the U.S. airline industry.

[Table of Contents](#)

**Agile “Peak Demand” Scheduling Strategy.** We flex our capacity by day of the week, month of the year and line of business to capture what we believe are the most profitable flying opportunities available from both our MSP home market and our growing network of non-MSP markets. As a result, our route network varies widely throughout the year. For the year ended December 31, 2019, we flew approximately 38% of our ASMs during our top 100 peak demand days of the year as compared to 15% of our ASMs during our bottom 100 demand days of the year. For 2019, our average fare was approximately % higher on our top 100 peak demand days as compared to the remaining days of the year. In 2019, only 3% of our routes were daily year round, compared to 8% for Frontier Airlines, 2% for Allegiant Travel Company, 42% for Spirit Airlines and 67% for Southwest Airlines. The following charts demonstrate that our schedule is highly variable by day of the week and month of year.

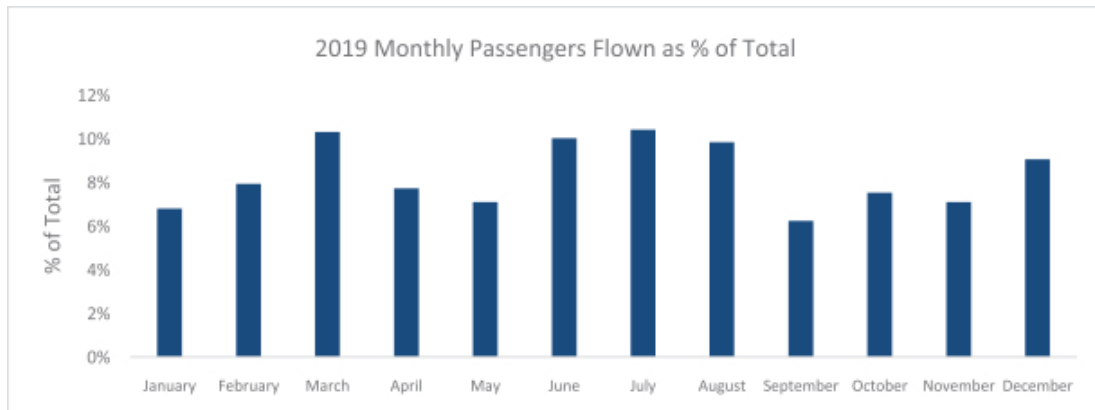
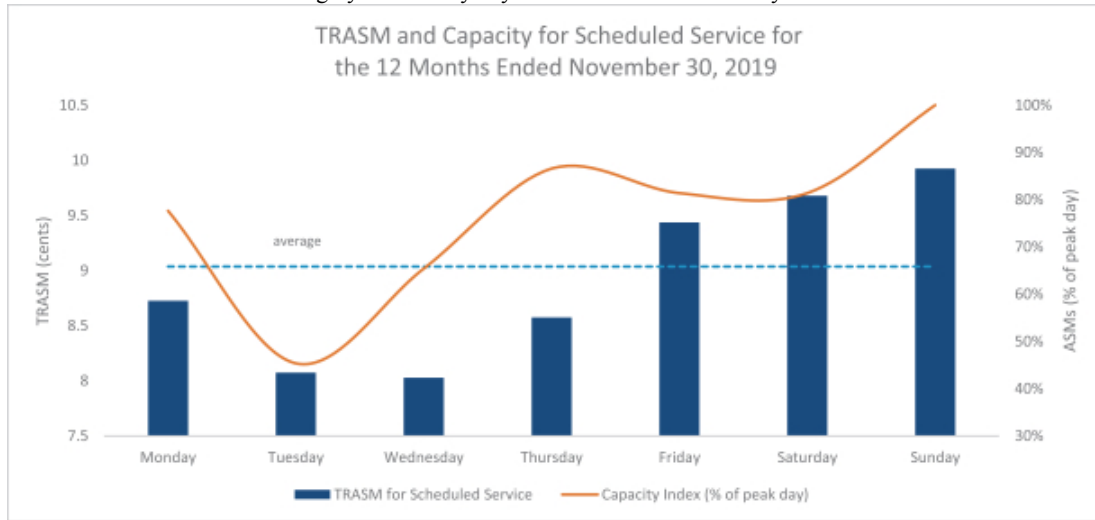

In addition to shifting aircraft across our network by season and day of week, we also shift between our scheduled service and charter businesses to maximize the return on our assets. We regularly schedule our fleet using what we refer to as “Power Patterns,” which involves scheduling aircraft and crew on trips that combine scheduled service and charter legs, dynamically replacing what would be lower margin scheduled service flights with charter opportunities. Our agility is supported by our variable cost structure and the cross utilization of our people and assets between our lines of business. We believe that the synergies to be gained from cross utilization will increase when we begin servicing the Amazon cargo business in the second quarter of 2020 because our



pilots will interchangeably be scheduled between scheduled service, charter and cargo flights. Our agile peak demand strategy allows us to generate TRASM by focusing on days with stronger demand.

**Tactical Mid-Life Fleet with Flexible Operations.** We maintain low aircraft ownership costs by purchasing mid-life Boeing 737-800 aircraft, which have a lower purchase price than comparable new Boeing 737-800 aircraft. This lower initial price generates the most significant cost advantage in our fleet strategy. Older aircraft on average require higher ongoing maintenance and repair costs, although the cyclical nature of airframe and engine maintenance intervals results in varying annual expenses that are not directly correlated to the age of the aircraft. When coupled with the lower purchase price, we believe that our mid-life aircraft achieve lower cost of ownership than new aircraft. Lower ownership costs allow us to maintain lower unit costs at lower levels of utilization. This allows us to concentrate our flying during periods of peak demand, which generates higher TRASM. In 2019, we flew our aircraft an average of 9.6 hours per day, which is the lowest among major U.S. airlines other than Allegiant Travel Company, which flies a similar low utilization model but serves smaller markets. Our single family aircraft fleet also has operational and cost advantages, such as allowing for optimization of crew scheduling and training and lower maintenance costs. Our fleet is highly reliable and we have a demonstrated ability to maintain our high completion factor during harsh weather conditions. For the year ended December 31, 2019, we had a completion factor of 99.8% across our system.

**Superior Low-Cost Product and Brand.** We have invested in numerous projects to create a well-regarded product and brand that we believe is superior to ULCCs while maintaining lower fares than LCCs and larger full service carriers. Some of the reasons that we believe we have a superior brand to ULCCs include:

- **Our Cabin Experience.** We have replaced all of our 737-800 seats with new state-of-the-art seats that comfortably recline and have full size tray tables. Our new seats have an average pitch of approximately 31 inches, giving our customers comparable legroom to Southwest Airlines and greater legroom than all ULCCs in the United States. We also added seat-back power, complimentary in-flight entertainment and free beverages to improve the overall flying experience for our customers. Such amenities are comparable to those offered by our LCC competitors and are not available on any ULCCs in the United States.
- **Our Digital Experience.** We have significantly improved the buying experience for our customers. We overhauled our passenger service system and transitioned to *Navitaire*, the premier passenger service system in the United States. *Navitaire* has decreased our overall website session length, decreased the percentage of failures to complete a transaction after accessing our website on a mobile device and increased the percentage of visits to our website that result in an airfare purchase. The transition to *Navitaire* has been one of our most important initiatives, improving the Sun Country customer experience, making our website booking more seamless, allowing us to create a large customer database and supporting ancillary revenue growth.

In addition to our product, we believe that our brand is well recognized and well regarded in the markets that we serve. In the fourth quarter of 2019, management conducted a study of 468 select individuals sourced primarily from third-party survey panel providers, across a variety of ages, income levels, home regions and home airports (including both MSP and non-MSP travelers), each of whom had traveled for leisure within the prior 24 months. Individuals selected for the survey included Sun Country passengers and a consumer sample provided by a third-party panel provider. 468 individuals responded to the study, 275 of whom had flown Sun Country Airlines. Based on that study: 79% of respondents who expressed a preference between airlines and had flown on both Sun Country Airlines and Allegiant Travel Company said they would rather fly on Sun Country Airlines; 77% of respondents who expressed a preference between airlines and had flown on both Sun Country Airlines and Frontier Airlines said they would rather fly on Sun Country Airlines; and 81% of respondents who expressed a preference between airlines and had flown on both Sun Country Airlines and Spirit Airlines said they would rather fly on Sun Country Airlines.

**Competitive Low Cost Structure.** Our transformation initiatives have reduced our unit costs significantly and have positioned us well for future growth. Since 2017, management has taken actions to reduce our cost

## [Table of Contents](#)

basis by approximately \$34 million on an annual basis and has initiatives in place to generate an additional \$10 million of annual cost savings going forward. Our completed and ongoing cost savings efforts include the outsourcing of Minneapolis station handling, renegotiation of our component maintenance agreement, fuel savings initiatives, catering cost reductions, renegotiation of distribution contracts and various other initiatives. Our CASM ex has declined from 7.79 cents for the year ended December 31, 2017 to cents for the year ended December 31, 2019. We are also focused on continuous cost rationalization and identifying potential redundancies or inefficiencies in our operations. We believe that our business model and strategy positions us well to maintain and improve our CASM despite having lower utilization rates than most of our peers.

***Strong Position in Our Profitable MSP Home Market.*** We have been based in the Minneapolis-St. Paul area since our founding over 35 years ago, where our brand is well-known and well-liked. We are the largest low-cost carrier operating at MSP, which is our largest base, and the second largest airline based on ASMs at MSP after Delta Air Lines, which primarily serves business and connecting traffic customers, while we primarily serve leisure customers. Excluding Delta Air Lines, we have nearly twice the capacity, as measured by ASMs, of any other competitor operating at MSP. However, our seat share at MSP is still meaningfully lower than Spirit Airlines' seat share in Fort Lauderdale and Frontier Airlines' seat share in Denver, and we believe there is significant room for us to grow in MSP through further market stimulation. We fly out of Terminal 2, which we believe is preferred by many flyers because of its smaller layout, shorter security wait times, close parking relative to check-in and full suite of retail shops. We currently utilize 8 of the 14 gates in Terminal 2. As a result of our focus on flying during seasonal peak periods, our well regarded brand and product and our strong position in Minneapolis, we enjoy a TRASM premium at MSP. We believe MSP is among the most profitable LCC bases in the United States and we believe we generate higher TRASM in MSP than any ULCC in the United States in its primary base.

***Synergistic and Profitable Charter Business.*** From 2017 through 2019, we have grown our charter revenue by approximately % while providing charter services to over 275 destinations in 25 countries across the world. Our charter business has several favorable dynamics including a large repeat customer base, stable demand and the ability to pass through certain costs, including fuel. Our diverse charter customer base includes casino operators, the U.S. Department of Defense, college sports teams and professional sports teams. We are the primary air carrier for the NCAA Division I National Basketball Tournament (known as "March Madness") and we flew over 100 college sports teams during 2019. Our charter business includes ad hoc, repeat, short-term and long-term service contracts (with pass through fuel arrangements and annual rate escalation) and most of our business is non-cyclical because the U.S. Department of Defense and sports teams still fly during economic downturns. Additionally, our stable and growing charter business complements seasonal and day-of-week focused scheduled passenger service by allowing us to optimize our aircraft scheduling and crew to the most profitable flying opportunities. In general, charter available seat miles are high in fall months when scheduled service operations are less favorable.

***Seasoned Management Team.*** As part of our transformation, we recruited a seasoned management team with decades of experience in aviation at some of the largest and most successful airlines in the world. Our Chief Executive Officer, Jude Bricker, joined Sun Country Airlines in July 2017 and has over 15 years of experience in the aviation industry, including serving as the Chief Operating Officer of Allegiant Travel Company from 2016 to 2017, at which point it was a public company. Our President and Chief Financial Officer, Dave Davis, joined Sun Country in April 2018 and has over 20 years of experience in the aviation industry, including previously serving as the Chief Financial Officer at Northwest Airlines and US Airways, which were both public companies. Other members of our management team have worked at airlines such as American Airlines, Delta Air Lines, Northwest Airlines and US Airways.

## Our Growth Strategy

Over the past two years, we have transformed our business to establish the infrastructure to support significant profitable growth going forward. Our main initiatives have included:

- *Network.* We launched 64 new markets and developed a repeatable network growth strategy. Our network strategy is expected to support passenger fleet growth to approximately 50 aircraft by the end of 2023.
- *Fleet.* We restructured our fleet with a focus on ownership of Boeing 737-800s with no planned lease redeliveries prior to 2024, allowing us to focus on growth with low capital commitments.
- *Customer.* We rebranded the airline around a leisure product with a significant ancillary revenue component. With the product transition complete, we can focus on stimulating demand in current and new markets and delivering a high quality travel experience.
- *Culture.* We installed a new management team with a cost-conscious ethos, which included moving our headquarters into a hangar at MSP.
- *Operations.* Through our transformation, we have maintained high standards of operational performance, including a 99.8% completion factor for the year ended December 31, 2019.

We believe our initiatives have provided us with a platform to continue to profitably grow our business. Key elements of our growth strategy include:

***Expand our “Peak Demand” Flying in Minneapolis and Beyond.*** We intend to continue to grow our network profitably both from MSP and on new routes outside of MSP by focusing on seasonal markets and day-of-the-week flying during periods of peak demand. We have expanded our network from 46 routes in 2017 to 98 routes currently planned for 2020, including expanding our routes that neither originate nor terminate in MSP from 5 routes in 2017 to 42 routes planned for 2020. We have expanded our operations aggressively in recent years, in part because we are able to efficiently redeploy assets. Furthermore, the reduction in our unit costs has expanded the number of markets that we can profitably serve. We have identified over 250 new market opportunities. We have a successful history of opening and closing stations to meet seasonal demand. Our future network plans include growing our network at our hub in Minneapolis to full potential, including adding frequencies on routes we already serve and adding new routes to leverage our large, loyal customer base in the area. Our long-term strategic plans have identified potential growth opportunities at MSP alone of 10 to 12 aircraft by the end of 2023.

We have also been rapidly growing, and expect to continue to grow, outside of MSP. Our customer friendly low fares have been well received in the upper Midwest and in large, fragmented markets elsewhere that we can profitably serve on a seasonal and/or day-of-week basis. Our upper Midwest growth is focused on cold to warm weather leisure routes from markets similar to Minneapolis, such as Madison, Wisconsin. Additionally, we have been adding capacity on large leisure trunk routes on a seasonal basis during periods when demand is high. Examples of such routes include Los Angeles to Honolulu and Dallas to Mexican beach destinations during the summer months. Our business model is ideally suited to seasonally serve these routes, which are highly profitable because fares are elevated during the months in which we fly them. Our long-term strategic plans have identified potential growth opportunities outside of MSP of 5 to 8 aircraft, as well as an additional 3 to 4 aircraft to support our charter operations, in each case, by the end of 2023.

***Continue to Increase Our Margins and Free Cash Flows.*** Since December 31, 2017, we have reduced our CASM ex from 7.79 cents to cents, a level comparable to ULCCs. When combined with our TRASM, which remains comparable to LCCs and higher than ULCCs, we generate highly competitive margins. Since 2017, management has taken actions to reduce our cost basis by approximately \$34 million on an annual basis and has initiatives in place to generate an additional \$10 million of annual cost savings going forward. Our completed and ongoing cost savings initiatives include outsourcing of Minneapolis station handling, reworking

## [Table of Contents](#)

of spare parts agreements, fuel savings initiatives, catering cost reductions, renegotiation of distribution contracts and various other initiatives. Our period of heavy investment in fleet renewal and transformative capital expenditures is largely behind us. As a result, we expect improvements in profit margins and free cash flow to support growth in the years ahead.

**Grow Our New Amazon Business.** On December 13, 2019, we signed a new six-year contract (with two, two-year extension options, for a maximum term of 10 years) with Amazon to provide air cargo transportation services with agreed pricing. Amazon will supply the aircraft and bear directly or reimburse us for certain operating expenses, including fuel and heavy maintenance. The aircraft will fly under our air carrier operating certificate and we will supply the crew, maintenance and insurance for the aircraft, all expenses that are well understood by us. Amazon has agreed to pay a fixed monthly fee per aircraft as well as a set rate per block hour flown. Flying is expected to begin in the second quarter of 2020 and be fully ramped up by the fourth quarter of 2020, at which point we will operate 10 cargo aircraft under the ATSA. We also expect that the Amazon operations will complement our core scheduled passenger business.

### **Our Scheduled Service Business**

We provide low-fare passenger airline service primarily to leisure and VFR travelers. Our low fares are designed to stimulate demand from price-sensitive travelers seeking a superior product to ULCCs. For the years ended December 31, 2019 and 2018, our average base fare (which excludes applicable taxes and governmental fees) was approximately \$ and \$136.42, respectively, and our number of scheduled service passengers were approximately 3.6 million and 2.6 million, respectively.

In addition to base fares, passengers can choose from a number of ancillary products for an additional cost. Sources of our ancillary revenue include baggage fees, seat selection and upgrade fees, itinerary service fees, on-board sales and sales of trip insurance. Part of our strategy has been to reduce base fares to stimulate demand while increasing ancillary revenue per passenger. Our on-board sales are also designed to enhance the customer experience. For the years ended December 31, 2019 and 2018, our average ancillary revenue per passenger was approximately \$ and \$21.70, respectively.

We also earn revenue from our Sun Country Vacations products, including commissions from the sale of third-party hotel rooms and rental cars. Our SCV products facilitate booking a flight and land package at a discounted price for our customers. As with many other carriers, we offer vacation products to promote “one stop shopping,” and, while a revenue source, this aspect of our business is not a key contributor to our growth strategy. In 2019, our bookings for SCV have been temporarily reduced due to transition issues with our new booking system. Our other revenue also includes revenue from the transportation of mail and cargo and our co-branded credit card.

### **Our Charter Business**

Our charter business services a variety of customers. For the year ended December 31, 2019, approximately % of our charter revenue was serviced under long-term contracts with casino operators. The remainder of our charter business consists largely of short-term or ad hoc arrangements with repeat customers with whom we have long-term relationships, including the U.S. Department of Defense and college and professional sports teams. Our charter business complements our scheduled service operations by filling in charter flying when scheduled service demand is lower, optimizing our aircraft utilization to the most profitable opportunities. Our strong customer relationships and flexibility in scheduling charter flying enables us to serve a variety of charter customers and we believe we are well-positioned to continue to grow our charter business.

In addition to service revenue, we also collect revenue for direct pass through costs, including fuel expense, which we are fully reimbursed for by our charter customers. Our charter revenue was approximately \$152 million in 2018 and \$ million in 2019.

### Route Network

Our network strategy operates across three key pillars: MSP, non-MSP and charter services. As Minnesota’s hometown airline, a substantial portion of our business is serving markets originating or ending in MSP. Our MSP network has grown 14% since 2017 and, in 2019, we served approximately 52 markets from MSP. We believe that our TRASM in our MSP network for the year ended December 31, 2019 is higher than any ULCC in its hub. We have a leading position at Terminal 2 in MSP, which is preferred by many flyers because of its smaller layout, shorter security wait times, close parking relative to check-in and full suite of retail shops. We account for approximately 50% of the departures and operate out of eight or more of Terminal 2’s 14 gates, as needed. We are the number two carrier at MSP by seat share. Moreover, we are the largest low-cost airline at MSP, with significant opportunity to continue to grow both seat share and destinations. Our long-term strategic plans have identified potential growth opportunities at MSP of 10 to 12 aircraft by the end of 2023.

Non-MSP service is an increasingly significant portion of our business, having grown approximately % since we launched our strategy to grow non-MSP service, now including approximately 49 markets. Non-MSP service has been a source of significant growth over the last two years. We continue to identify large demand markets where other airlines have been unable to respond to market needs during periods of seasonal demand. We have a successful history of opening and closing stations to meet seasonal demand. Since 2017, we have launched 64 new markets, 26 of which we have subsequently closed. As part of the on-going assessment of market opportunities, we continue to identify future growth opportunities, primarily from Midwest locations to warm weather leisure destinations and large markets with fragmented and seasonal demand peaks. Our long-term strategic plans have identified potential growth opportunities outside of MSP of 5 to 8 aircraft by the end of 2023.

Below are maps of the scheduled service routes we operated in 2017 and 2019 (including routes we operate on a seasonal basis):

#### 2017 Route Map



2019 Route Map



Our charter business is a core and integral piece of our network strategy that leverages our highly flexible operating certificate and flexible labor force to serve markets worldwide. Charter service revenue constituted approximately % of revenue for the year ended December 31, 2019, and capacity grew approximately % over the last two years. The charter and scheduled service businesses complement each other as our integrated scheduling allows the most profitable use of the aircraft, either scheduled or charter, to be selected on a segment by segment basis. Aircraft and crew utilization can be maximized by filling in charter flying in periods when scheduled service flying is less profitable.

Our air carrier operating certificate, labor agreements and operating capabilities allow us to fly to numerous destinations worldwide. We captured approximately 12.6% of approximately \$1.2 billion spent on domestic, narrow body charter service in 2018, making us the third largest narrow body charter provider. Despite the current breadth of our charter business, we believe there is still room to grow into this large and fragmented market. We have identified several growth opportunities across potential sports teams, VIP individuals, government, and leisure contracts. Additionally, we have longstanding relationships with our charter customers who continue to rely on us as their trusted charter provider.

**Competition**

The airline industry is highly competitive. The principal competitive factors in the airline industry are ticket prices, flight schedules, aircraft type, passenger amenities, customer service, reputation and frequent flyer programs.

Our competitors and potential competitors include both legacy network and low-cost airlines. Our competitors on domestic routes are Alaska Airlines, Allegiant Travel Company, American Airlines, Delta Air Lines, Frontier Airlines, Hawaiian Airlines, JetBlue Airways, Southwest Airlines, Spirit Airlines and United Airlines. Our principal competitive advantages are our agile peak demand scheduling strategy, our superior low-cost product and brand, our competitive low-cost structure, our strong position in our profitable MSP home market and our profitable and synergistic charter business. We also believe the association of our brand with a high level of operational performance differentiates us from our competitors and enables us to generate greater customer loyalty. Our completion factor for the nine months ended September 30, 2019 was higher than any ULCC.

Our cost initiatives have yielded significant improvements in CASM over the last two years. As a result of these improvements and our flexibility to serve seasonal and year-round markets, we believe we are better

## [Table of Contents](#)

positioned to offer a schedule tailored to properly serve periods of peak demand than our peers. The chart below compares our CASM ex and utilization with our competitors and demonstrates our ability to maintain low unit costs at lower aircraft utilization. The majority of our competitors maintain higher utilization to keep their unit costs low which makes it difficult for them to serve markets on a highly seasonal or day-of-week basis. As such, we believe our low CASM ex coupled with relatively low utilization is a competitive advantage. The only low-cost airline that is able to maintain a lower CASM ex at lower utilization is Allegiant Travel Company, which traditionally has focused on secondary markets and airports.

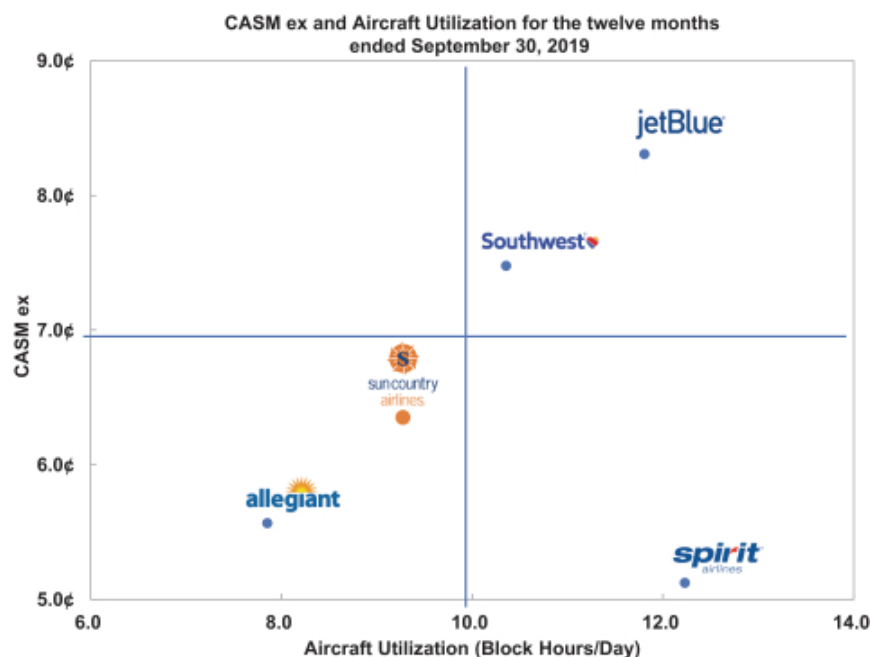

Our ability to maintain low unit costs at low utilization provides us with a competitive advantage to execute our agile peak demand network planning structure. Our peak demand strategy allows us to move into new markets quickly during periods when demand is maximized and there is less competitive pricing pressure.

See also “*Risk Factors—Risks Related to Our Industry—The airline industry is exceedingly competitive, and we compete against LCCs, ULCCs and legacy network airlines; if we are not able to compete successfully in our markets, our business will be materially adversely affected.*”

### **Seasonality**

The airline industry has significant seasonal fluctuation in demand. Our network strategy is designed to take advantage of the seasonal nature of the airline business by concentrating our flying in seasons when demand is strongest and flying significantly less in seasons when demand is lower. As a result, our business is subject to significant seasonal fluctuations, especially our scheduled service. While our passenger business will remain highly seasonal, we expect that our Amazon operations will have the effect of mitigating seasonal troughs.

Traditionally, our business is geared towards north to south travel from MSP and the upper Midwest in the winter months, our strongest travel season. During the summer months, we focus on VFR traffic from MSP and leisure travelers originating in non-MSP markets. Although our actual results vary by season, we pride ourselves on the ability to adjust our route network and charter service to accommodate seasonality.



## **Distribution**

We sell our flights through direct and indirect distribution channels with the goal of selling in the most efficient way across our customer base. Our direct distribution channels include our website and our call center and our indirect distribution channels include third parties such as travel agents and online travel agencies, or OTAs (e.g., Priceline and websites owned by Expedia, including Orbitz and Travelocity).

Our direct distribution channels are our lowest cost methods of distributing our product. In addition, they provide more opportunities to sell ancillary products and services, such as baggage services and seat selection and upgrades. With the introduction of our new *Navitaire*-based reservation system and website in June 2019, we have experienced a significant increase in the proportion of our bookings that are sold through direct channels. 2019 sales through direct channels accounted for % of our total passenger revenue, compared to 58% in 2017.

Indirect distribution channels remain important outlets to sell our flights. Our movement in and out of markets where we may not have an established brand presence is facilitated by the availability of our inventory through GDS companies (e.g., Amadeus, Sabre and Travelport). We also generate sales through OTAs, which also broadens our ability to sell in highly seasonal markets. Sales through relatively higher cost indirect channels have fallen to 38% in 2019 from 42% in 2017.

## **Marketing**

We are focused on direct-to-consumer marketing targeted at our core leisure and VFR travelers who pay for their own travel costs. Our marketing message is designed to convey our affordable and convenient flight options to leisure destinations. We often include our low base fares in marketing materials in order to stimulate demand.

Our marketing tools are our proprietary email distribution list consisting of over 850,000 email addresses, our Sun Country Rewards program, as well as advertisements online, on television, radio, digital billboards and other channels. Our objective is to use our low prices, quality customer service, and differentiated in-flight product to stimulate demand and drive customer loyalty.

We have a team of business development professionals who utilize business-to-business methods to identify opportunities and develop and maintain relationships with potential charter customers.

We spent approximately % and 4.8% as a percentage of total revenues on marketing, brand and distribution for the years ended December 31, 2019 and 2018, respectively.

## **Loyalty Program**

Our Sun Country Rewards frequent flyer program rewards and encourages customer loyalty and we believe it is well tailored to serving the leisure passenger. Points earned are treated like currency and can be applied towards the purchase of all or a portion of our tickets. This makes our program more valuable to leisure customers who travel less frequently and would have difficulty accumulating enough points to get discounted travel on other airlines. The Sun Country Airlines Visa Signature Card is the primary vehicle whereby customers earn points and our frequent flyer program is geared specifically towards supporting adoption and continued use of the credit card. Sun Country Rewards offers award travel on every flight without blackout dates. Points expire 36 months after the date they were earned, except that points held by Sun Country Visa cardholders do not expire so long as the holder uses the card.

## **Customers**

We believe our customers are primarily leisure and VFR travelers who are paying for their own ticket and who make their purchase decision based largely on price. These customers respond well to demand stimulation based on low base fares. Our network is agile and is adjusted for seasonal demand shifts. In the winter months, we largely focus on taking customers to warm weather destinations in the southern United States, Mexico and the Caribbean. In the other times of the year, we focus on VFR travelers to major markets and also provide service in markets where leisure or price sensitive customer demand is strong.



## [Table of Contents](#)

We believe our product appeals to price-sensitive customers because we give them the choice to pay only for the products and services they want. Overall, our business model is designed to deliver what we believe our customers want: low fares and a high quality flight experience.

We also complement our core business with charter operations. A significant portion of our business consists of repeat customers with whom we have long-term relationships, including several large casinos, college and professional sports teams. We have the ability to tailor our schedule to the specific needs of our charter customers, providing reliable operations, high completion factor and reasonable pricing for these customers.

### Operational Performance

We are committed to delivering excellent operational performance, even in extreme weather conditions, which we believe supports our “peak demand,” leisure-focused business model and will strengthen customer loyalty and attract new customers. Our operational performance is enabled by our capable and dedicated workforce in maintenance and ground operations, as well as our highly capable fleet of 737-NG aircraft, which are equipped to operate in adverse weather conditions worldwide. Our primary operational metric is completion factor because most of our markets are operated less than daily. Our strong completion factor of 99.8% for the year ended December 31, 2019 and 99.5% for the year ended December 31, 2018 is a significant competitive advantage. In addition to being able to complete flights in challenging weather, we are known for our dedication to getting passengers to their destination. Our high completion factor is critical to providing our customers with the utmost confidence and retaining their loyalty in the future. Our completion factor compares favorably to our competitors, with Sun Country leading among key competitor airlines as indicated below for the twelve months ended September 30, 2019.

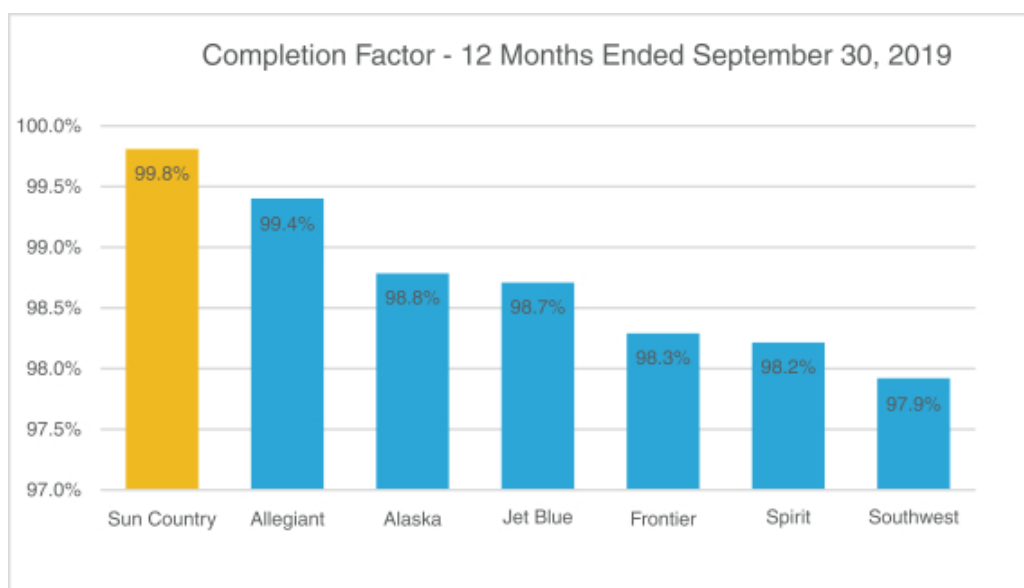

Source: DOT Bureau of Transportation Statistics.

Charter operations are an important part of our business and our largest single customer is the U.S. Department of Defense. We consistently receive high marks for service and reliability. Our ratings from the Department of Defense for our charter flights for the year ended September 30, 2019 was 98% for domestic performance and 97% for international performance, putting us in the “exceptional” rating category. We are committed to serving not only our Department of Defense customers, but all our charter customers, with the highest levels of safety, reliability and performance.

## Fleet

We fly only Boeing 737-NG aircraft, which we believe provides us significant operational and cost advantages compared to airlines that operate multiple fleet types. Flight crews are interchangeable across all of our aircraft, and maintenance, spare parts inventories and other operational support are highly simplified relative to more complex fleets. With the addition of the Amazon cargo operations, we expect that these efficiencies will remain intact.

As of December 31, 2019, we had a fleet of Boeing 737-NG aircraft, consisting of 30 Boeing 737-800s, including two seasonal aircraft, and one Boeing 737-700. The average age of the passenger aircraft in our fleet was approximately 15 years as of December 31, 2019. Of the non-seasonal aircraft, 24 were financed under operating or capital leases as of December 31, 2019. The 2019-01 EETC will significantly reduce our financing costs as we use it to convert a portion of our leased aircraft to owned aircraft, as well as refinance some of our currently owned aircraft in the first half of 2020. This will substantially reduce our aircraft financing costs in 2020 and beyond. There are no scheduled aircraft lease redeliveries prior to 2024. Our current fleet plan calls for growth to 50 passenger aircraft by the end of 2023.

## Aircraft Fuel

Aircraft fuel is our largest expense representing approximately % and 30.1% of our total operating costs for the years ended December 31, 2019 and 2018, respectively. The price and availability of jet fuel are volatile due to global economic and geopolitical factors as well as domestic and local supply factors. Our historical fuel consumption and costs were as follows:

	Year Ended December 31,	
	2019	2018
Gallons consumed (in thousands)	78,042	64,981
Average price per gallon	\$ 2.26	\$ 2.34

Average price per gallon includes related fuel fees and taxes but excludes fuel-hedging gains and losses.

From time to time, we may enter into fuel derivative contracts in order to mitigate the risk to our business from future volatility in fuel prices, but such contracts may not fully protect us from all related risks. The intention of our fuel hedging program is not to manage earnings but rather to protect our liquidity. As of December 31, 2019, we had hedges in place for approximately 61% of our projected fuel requirements for scheduled service operations in 2020, with all of our then existing options expected to be exercised or expire by the end of 2021. Generally speaking, our charter operations and the ATSA have pass-through provisions for fuel costs, and as such we do not hedge our fuel requirements for that portion of our business. Our hedges in place at the end of 2019 consisted of collars, and the underlying commodities consisted of both Gulf Coast Jet Fuel contracts as well as West Texas Intermediate Crude Oil contracts.

## Maintenance and Repairs

We have an FAA mandated and approved maintenance program, which is administered by our technical operations department. Our maintenance technicians undergo extensive initial and recurrent training. Aircraft maintenance and repair consists of routine and non-routine maintenance, and work performed is divided into three general categories: line maintenance, heavy maintenance and component service.

Line maintenance work is handled by our employees and contractors and consists of work performed between flights or overnight. Performing effective line maintenance is critical to maintaining a reliable operation and represents the majority of and most extensive maintenance we perform. Line maintenance consists of routine daily and weekly scheduled maintenance checks on our aircraft. We maintain Sun Country technicians in Minneapolis, with limited line maintenance capabilities in Gulfport, Mississippi, Dallas-Fort Worth, Texas and Laughlin, Nevada. All other line maintenance is provided by third-party contractors as needed.

## [Table of Contents](#)

Heavy maintenance consists of engine and airframe overhauls, which are quite extensive and can take up to four months to complete. We maintain an inventory of spare engines to provide for continued operations during engine maintenance events. Major airframe maintenance checks consist of a series of complex tasks that generally take from one to four weeks to accomplish and are performed on a set schedule with varying repeat intervals. Due to our relatively small fleet size and projected fleet growth, we believe outsourcing all of our heavy maintenance, engine restoration and major part repair is more economical.

We also outsource component maintenance and heavy airframe maintenance. Component maintenance consists of the ongoing and routine maintenance of aircraft components that can be removed and reinstalled. These contracts cover the majority of our aircraft component inventory acquisition, replacement and repairs, thereby reducing the need to carry extensive spare parts inventory.

### **Employees**

As of December 31, 2019, we had 1,558 employees.

FAA regulations require pilots to have commercial licenses with specific ratings for the aircraft to be flown and to be medically certified as physically fit to fly. FAA and medical certifications are subject to periodic renewal requirements including recurrent training and recent flying experience. Mechanics, quality-control inspectors and flight dispatchers must be certificated and qualified for specific aircraft. Flight attendants must have initial and periodic competency training and qualification. Training programs are subject to approval and monitoring by the FAA. Management personnel directly involved in the supervision of flight operations, training, maintenance and aircraft inspection must also meet experience standards prescribed by FAA regulations.

Approximately 59% of our employees are represented by labor unions under collective-bargaining agreements as set forth in the table below. Our pilots are represented by the Air Line Pilots Association, our flight attendants are represented by the International Brotherhood of Teamsters and our dispatchers are represented by the Transport Workers Union. We entered into NMB mediation with TWU on September 19, 2018. On December 3, 2019, our dispatchers approved a new contract, now amendable on November 14, 2024. Our collective bargaining agreement with our flight attendants is currently amendable and we are in negotiations with IBT. Our collective bargaining agreement with our pilots is amendable on October 31, 2020.

<u>Employee Groups</u>	<u>Number of Employees</u>	<u>Representative</u>	<u>Status of Agreement/Amendable Date</u>
Pilots	374	Air Line Pilots Association (ALPA)	Amendable in October 2020
Flight Attendants	524	International Brotherhood of Teamsters (IBT)	Amendable in December 2019
Dispatchers	21	Transport Workers Union (TWU)	Amendable in November 2024

The RLA governs our relations with labor organizations. Under the RLA, the collective bargaining agreements generally do not expire, but instead become amendable as of a stated date. If either party wishes to modify the terms of any such agreement, they must notify the other party in the manner agreed to by the parties. Under the RLA, after receipt of such notice, the parties must meet for direct negotiations, and if no agreement is reached, either party may request the NMB to appoint a federal mediator. The RLA prescribes no set timetable for the direct negotiation and mediation process. It is not unusual for those processes to last for many months, and even for a few years. If no agreement is reached in mediation, the NMB in its discretion may declare at some time that an impasse exists, and if an impasse is declared, the NMB proffers binding arbitration to the parties. Either party may decline to submit to arbitration. If arbitration is rejected by either party, a 30-day “cooling off” period commences. During that period (or after), a Presidential Emergency Board, or PEB, may be established, which examines the parties’ positions and recommends a solution. The PEB process lasts for 30 days and is followed by another “cooling off” period of 30 days. At the end of a “cooling off” period, unless an agreement is

## [Table of Contents](#)

reached or action is taken by Congress, the labor organization may strike and the airline may resort to “self-help,” including the imposition of any or all of its proposed amendments and the hiring of new employees to replace any striking workers. Congress and the President have the authority to prevent “self-help” by enacting legislation that, among other things, imposes a settlement on the parties.

### **Safety and Security**

Safety is the most important thing we do and we are committed to the safety and security of our passengers and employees. In addition to complying with federally regulated safety and security standards, we strive to create a culture of safety and security that achieves the highest possible industry standard.

Some of the safety and security measures we have taken include: aircraft security and surveillance, positive bag matching procedures, enhanced passenger and baggage screening and search procedures and securing of cockpit doors. In addition, we have invested in a safety management system platform, which allows for anonymous reporting of safety concerns by employees and business partners and promotes active participation in the identification, reduction and elimination of hazards. We participate in ASIAs (FAA Aviation Safety Information Analysis and Sharing System), which is a central conduit for the exchange of safety information among its stakeholders, and FOQA (Flight Operations Quality Assurance), a structured program to gather and aggregate electronically recorded flight operations data for the purpose of identifying areas where safety, efficiency and training can be improved. Furthermore, we voluntarily completed the IATA Operational Safety Audit in June 2019, which is the benchmark for global safety management in airlines.

Our ongoing focus on safety relies on training our employees to proper standards and providing them with the tools and equipment they require so they can perform their job functions in a safe and efficient manner. Safety in the workplace targets several areas of our operation including: flight operations, maintenance, in-flight, dispatch and station operations. In addition, we recently conducted a safety culture survey, the results of which we have used to create action plans for areas of opportunity.

### **Facilities**

In most of the airports we serve, we do not directly lease facilities, but rather operate under flexible common use agreements. This facilitates our strategy of entering and exiting markets to service periods of peak demand. Our terminal passenger service facilities, which include ticket counters, gate space, operational support space and baggage service offices, generally have month-to-month terms or are used on a per use basis. For any leased space we are typically responsible for maintenance, insurance and other facility-related expenses and services under these agreements. We also have entered into use agreements at many of the airports we serve that provide for the non-exclusive use of runways, taxiways and other facilities. Landing fees under these agreements are based on the number of landings and weight of the aircraft.

We primarily operate out of eight of 14 gates at Terminal 2 at MSP, five of which are assigned to us on a priority basis with common use access to the remaining gates. Our leases for our terminal passenger service facilities, which include operational support space and baggage service offices, are leased on a month-to-month basis. Gate space and ticket counter space is used and billed on a per operation (each arrival and departure) basis until an annual operating cap is met. Our operating lease also includes two hangars:

- 108,000 square foot maintenance hangar, which includes office space and is where we provide certain maintenance on our aircraft; and
- 90,000 square foot office and hangar facility which has been converted into our corporate headquarters.

For charter service with an origin or destination where we do not have ground handling capabilities, we arrange with airports, fixed base operators or military bases to provide ground services on an as needed basis.

Our principal executive offices and headquarters are presently located on MSP property at 2005 Cargo Road, Minneapolis, Minnesota 55450, consisting of approximately 90,000 square feet, under a lease which expires in February 2029.

## **Community Partnerships**

As a Minnesota-based company, it is an important part of our culture to give back to the community in which we work and live. We have several key community partnership initiatives, some of which are:

- Everyday Heroes – a program where we recognize one hero every month with a \$500 Sun Country travel voucher, with recognition through TV and radio properties owned by our media partner.
- Make-A-Wish Minnesota – we have a three-year commitment with Make-A-Wish MN to provide travel to every Minnesota Wish Kid flying to a destination Sun Country serves.
- Hennepin Theatre Trust – we support the Trust’s Spotlight Education program, focused on education for local performing arts students.

## **Insurance**

We maintain insurance policies we believe are of types customary in the airline industry and as required by the DOT, lessors and other financing parties. The policies principally provide liability coverage for public and passenger injury; damage to property; loss of or damage to flight equipment; fire; auto; directors’ and officers’ liability; advertiser and media liability; cyber risk liability; fiduciary; workers’ compensation and employer’s liability; and war risk (terrorism).

## **Foreign Ownership**

Under federal law and DOT policy, we must be owned and controlled by U.S. citizens. The restrictions imposed by federal law and DOT policy currently require that at least 75% of our voting stock must be owned and controlled, directly and indirectly, by persons or entities who are citizens of the United States (“U.S. citizens”), as that term is defined in 49 U.S.C. §40102(a)(15), that our president and at least two-thirds of the members of our board of directors and other managing officers be U.S. citizens, and that we be under the actual control of U.S. citizens. In addition, at least 51% of our total outstanding stock must be owned and controlled by U.S. citizens and no more than 49% of our stock may be owned or controlled, directly or indirectly, by persons or entities who are not U.S. citizens and are from countries that have entered into “open skies” air transport agreements with the United States which allow unrestricted access between the United States and the applicable foreign country and to points beyond the foreign country on flights serving the foreign country. We are currently in compliance with these ownership provisions. For a discussion of the procedures we instituted to ensure compliance with these foreign ownership rules, please see *“Description of Capital Stock—Limited Ownership and Voting by Foreign Owners.”*

## **Government Regulation**

### ***Aviation Regulation***

The airline industry is heavily regulated, especially by the federal government. Two of the primary regulatory authorities overseeing air transportation in the United States are the DOT and the FAA. The DOT has authority to issue certificates of public convenience and necessity, exemptions and other economic authority required for airlines to provide domestic and foreign air transportation. International routes and international code-sharing arrangements are regulated by the DOT and by the governments of the foreign countries involved. A U.S. airline’s ability to operate flights to and from international destinations is subject to the air transport agreements between the United States and the foreign country and the carrier’s ability to obtain the necessary authority from the DOT and the applicable foreign government.

The U.S. government has negotiated “open skies” agreements with many countries, which allow unrestricted access between the United States and the applicable foreign country and to points beyond the foreign country on flights serving the foreign country. With certain other countries, however, the United States has a restricted air transportation agreement. Our international flights to Mexico are governed by a liberalized bilateral air transport which the DOT has determined has all of the attributes of an “open skies” agreement. Changes in the

## [Table of Contents](#)

aviation policies of the United States, Mexico or other countries in which we operate could result in the alteration or termination of the corresponding air transport agreement, diminish the value of our international route authorities or otherwise affect our operations to/from these countries.

The FAA is responsible for regulating and overseeing matters relating to the safety of air carrier flight operations, including the control of navigable air space, the qualification of flight personnel, flight training practices, compliance with FAA airline operating certificate requirements, aircraft certification and maintenance requirements and other matters affecting air safety. The FAA requires each commercial airline to obtain and hold an FAA air carrier certificate. We currently hold an FAA air carrier certificate.

### ***Airport Access***

In the United States, the FAA currently regulates the allocation of take-off and landing authority, slots, slot exemptions, operating authorizations or similar capacity allocation mechanisms, which limit take-offs and landings, at certain airports. Level 1 is assigned where the capacity of airport infrastructure is generally adequate to meet demands of airport users at all times and therefore there is no extensive pattern of delays. Level 2 is assigned where there is potential for congestion during some periods of the day, week or season, which can be resolved by schedule adjustments mutually agreed between the airlines and schedule facilitator. Level 3 is assigned where (i) demand for airport infrastructure significantly exceeds the airport's capacity during the relevant period; (ii) expansion of airport infrastructure to meet demand is not possible in the short term; (iii) attempts to resolve the problem through voluntary schedule adjustments have failed or are ineffective; and (iv) as a result, a process of slot allocation is required whereby it is necessary for all airlines and other aircraft operators to have a slot allocated by a coordinator in order to arrive or depart at the airport during the periods when slot allocation occurs. We do not currently operate in or out of any Level 3 airports. We currently operate, or plan to operate, in and out of San Francisco International Airport (SFO), Los Angeles International Airport (LAX), Chicago O'Hare International Airport (ORD) and Newark International Airport (EWR), which are Level 2 airports. We generally do not have any difficulty accessing these airports.

In addition, we launched service to Vancouver, Canada in 2020. Terminal access for Vancouver is controlled by Vancouver Airport Authority due to facility constraints. We have obtained the access we need to accommodate our planned service.

### ***Consumer Protection Regulation***

The DOT also has jurisdiction over certain economic issues affecting air transportation and consumer protection matters, including unfair or deceptive practices and unfair methods of competition, lengthy tarmac delays, airline advertising, denied boarding compensation, ticket refunds, baggage liability, contracts of carriage, customer service commitments, consumer notices and disclosures, customer complaints and transportation of passengers with disabilities. The DOT frequently adopts new consumer protection regulations, such as rules to protect passengers addressing lengthy tarmac delays, chronically delayed flights, codeshare disclosure and undisclosed display bias. The DOT also has authority to review certain joint venture agreements, marketing agreements, code-sharing agreements (where an airline places its designator code on a flight operated by another airline) and wet-leasing agreements (where one airline provides aircraft and crew to another airline) between carriers and regulates other economic matters such as slot transactions.

### ***Security Regulation***

The TSA and the CBP, each a division of the U.S. Department of Homeland Security, are responsible for certain civil aviation security matters, including passenger and baggage screening at U.S. airports, and international passenger prescreening prior to entry into or departure from the United States. International flights are subject to customs, border, immigration and similar requirements of equivalent foreign governmental agencies. We are currently in compliance with all directives issued by such agencies.

### ***Environmental Regulation***

We are subject to various federal, state, foreign and local laws and regulations relating to the protection of the environment and affecting matters such as air emissions (including greenhouse gas, or GHG, emissions), noise emissions, discharges to surface and subsurface waters, safe drinking water, and the use, management, release, discharge and disposal of, and exposure to, materials and chemicals.

We are also subject to environmental laws and regulations that require us to investigate and remediate soil or groundwater to meet certain remediation standards. Under certain laws, generators of waste materials, and current and former owners or operators of facilities, can be subject to liability for investigation and remediation costs at locations that have been identified as requiring response actions. Liability under these laws may be strict, joint and several, meaning that we could be liable for the costs of cleaning up environmental contamination regardless of fault or the amount of wastes directly attributable to us.

### ***GHG Emissions***

Concern about climate change and greenhouse gases may result in additional regulation or taxation of aircraft emissions in the United States and abroad. In particular, in June 2015, the EPA announced a proposed endangerment finding that aircraft engine GHG emissions cause or contribute to air pollution that may reasonably be anticipated to endanger public health or welfare. If the EPA makes a final, positive endangerment finding, the EPA is obligated under the Clean Air Act to set GHG emissions standards for aircraft. Several states are also considering or have adopted initiatives to regulate emissions of GHGs, primarily through the planned development of GHG emissions inventories and/or regional cap-and-trade programs. On March 6, 2017, ICAO adopted new carbon dioxide certification standards for new aircraft beginning in 2020. The new CO<sub>2</sub> standards will apply to new aircraft type designs from 2020, and to aircraft type designs already in production as of 2023. In-production aircraft that do not meet the standard by 2028 will no longer be able to be produced unless their designs are modified to meet the new standards.

In addition, in October 2016, the ICAO adopted the Carbon Offsetting and Reduction Scheme for International Aviation (“CORSIA”), which is a global, market-based emissions offset program designed to encourage carbon-neutral growth beyond 2020. The CORSIA will increase operating costs for us and other U.S. airlines that operate internationally. The CORSIA is being implemented in phases, with information sharing beginning in 2019 and a pilot phase beginning in 2021. Certain details are still being developed and the impact cannot be fully predicted.

### ***Noise***

Federal law recognizes the right of airport operators with special noise problems to implement local noise abatement procedures so long as those procedures do not interfere unreasonably with interstate and foreign commerce and the national air transportation system, subject to FAA review under the Airport Noise and Control Act (ANCA) of 1990. These restrictions can include limiting nighttime operations, directing specific aircraft operational procedures during take-off and initial climb and limiting the overall number of flights at an airport. While we have had sufficient scheduling flexibility to accommodate local noise restrictions in the past, our operations could be adversely impacted if ICAO or locally imposed regulations become more restrictive or widespread.

### ***Other Regulations***

Airlines are also subject to various other federal, state, local and foreign laws and regulations. For example, the U.S. Department of Justice has jurisdiction over certain airline competition matters. The privacy and security of passenger and employee data is regulated by various domestic and foreign laws and regulations.

**Legal Proceedings**

We are subject to commercial litigation claims and to administrative and regulatory proceedings and reviews that may be asserted or maintained from time to time. We currently believe that the ultimate outcome of such lawsuits, proceedings and reviews will not, individually or in the aggregate, have a material adverse effect on our financial position, liquidity or results of operations.



## MANAGEMENT

The following table sets forth the name, age and position of each of our executive officers and directors as of the date of this prospectus.

<u>Name</u>	<u>Age</u>	<u>Position</u>
Jude Bricker	46	Chief Executive Officer; Director
Dave Davis	53	President and Chief Financial Officer; Director
Gregory Mays	51	Chief Operating Officer and Executive Vice President
Eric Levenhagen	38	Chief Administrative Officer, General Counsel and Secretary
Jeffrey Mader	59	Chief Information Officer and Executive Vice President
Brian Davis	40	Chief Marketing Officer and Executive Vice President
Grant Whitney	43	Chief Revenue Officer and Executive Vice President
John Gyurci	49	Vice President, Finance, and Chief Accounting Officer
Bill Trousdale	51	Vice President, Financial Planning & Analysis, and Treasurer
R. Brian Davis	52	Vice President, Ground Operations
Marc Becker	47	Director
Joshua Black	33	Director
Antoine Munfakh	37	Director
David Siegel	58	Executive Chairman; Director
Juan Carlos Zuazua	40	Director

The following are brief biographies describing the backgrounds of the executive officers and directors of the Company.

**Jude Bricker** has served as our Chief Executive Officer since July 2017. Mr. Bricker has 15 years of experience in the aviation industry. He previously served as the Chief Operating Officer of Allegiant Travel Company from January 2016 to June 2017, as well as various other leadership roles from 2006 to 2016. As Chief Operating Officer of Allegiant Travel Company, Mr. Bricker was the senior executive responsible for marketing, network, operations, treasury, fleet, scheduling, pricing, ancillary products, digital, distribution, charters, loyalty and investor relations. From July 2004 to May 2006, Mr. Bricker was a finance manager at American Airlines. Mr. Bricker holds a BS in Civil Engineering from Texas A&M University and an MBA from the University of Texas.

**Dave Davis** has served as our Chief Financial Officer since April 2018 and as our President since December 2019. Prior thereto, from January 2018 to April 2018, Mr. Davis was an Advisor at Inadvia, an advertising trading platform. In June 2017, Mr. Davis founded Kintsugi Holdings, LLC where he remains Managing Partner. From July 2014 to February 2017, Mr. Davis served as Chief Executive Officer, and from November 2012 to June 2014, served as Chief Financial Officer and Chief Operating Officer, of Global Eagle Entertainment, Inc., a leading global provider of media content and satellite-based connectivity systems for use in commercial aviation, maritime and remote land-based applications. Prior thereto, Mr. Davis was the Executive Vice President and Chief Financial Officer of Northwest Airlines, Inc., the world's fourth largest airline prior to its sale to Delta Air Lines in 2008. Additionally, Mr. Davis has held various finance leadership positions at Northwest Airlines, US Airways and Budget Group. Mr. Davis received a Bachelor of Aerospace Engineering and Mechanics degree and an MBA from the University of Minnesota.

**Gregory Mays** has served as our Chief Operating Officer since June 2019. Mr. Mays previously worked as a Senior Industry Advisor with Boston Consulting Group from February 2019 to June 2019 where he led operations teams in maintenance and engineering, airport operations, cargo operations, labor relations, and design/test engineering. Prior thereto, Mr. Mays was Vice President of Labor Relations from December 2015 to December 2018 and Vice President of Maintenance and Engineering from December 2012 to January 2016 at Alaska Airlines. Additionally, Mr. Mays worked at Delta Air Lines for over 13 years in various operations

## [Table of Contents](#)

capacities. Mr. Mays earned a BS in Aerospace Engineering from the University and Alabama and an MBA from Emory University.

**Eric Levenhagen** has served as our Chief Administrative Officer since April 2018 and has served as our Executive Vice President of Legal since April 2017 and as General Counsel since September 2016. Previously, Mr. Levenhagen served as Assistant General Counsel at Landmark Aviation, an aviation services company from September 2014 to August 2016. Prior thereto, Mr. Levenhagen was a practicing corporate attorney from September 2009 to September 2014 and Adjunct Professor of Business Law and Ethics at Belhaven University from January 2010 to July 2016. He received a BS from Texas Christian University and a JD from Mitchell Hamline School of Law in St. Paul, Minnesota.

**Jeffrey Mader** has served as our Chief Information Officer since April 2018. He previously served as Chief Information Officer at Imagine! Print Solutions from August 2015 to June 2017. From January 1991 to August 2014, Mr. Mader held various senior leadership positions on the technology team at Target. Since 2009, Mr. Mader has been on the board of United Through Reading, a nonprofit organization. He holds a BS in Computer Science, Finance and Management from Minnesota State University, Mankato and an MBA from the University of St. Thomas (St. Paul).

**Brian Davis** has served as our Chief Marketing Officer since January 2018. Mr. Davis previously served as Special Advisor on Business Strategy to Wingo, a subsidiary of Copa Airlines, from June 2017 to January 2018. From 2005 to 2017, Mr. Davis served in a number of leadership roles at Allegiant Travel Company, including as Vice President of Marketing and Sales from May 2014 to June 2017. Additionally, Mr. Davis was previously an Adjunct Professor of Marketing and PR at California State University, Los Angeles. He holds an MBA from the Wharton School of the University of Pennsylvania.

**Grant Whitney** has served as our Chief Revenue Officer since May 2019. Prior thereto, he spent nine years at United Airlines from 2010 to 2018, most recently in the role of Vice President of Domestic Network Planning and Aircraft Scheduling from August 2016 to March 2018. Prior to that, Mr. Whitney served as Director of International Planning at US Airways, and spent 8 years at Northwest Airlines in various commercial and network-planning functions. Mr. Whitney holds a BA in Economics from Carleton College and an MBA from the Carlson School of Management at the University of Minnesota.

**John Gyurci** has served as our Chief Accounting Officer since October 2018. Mr. Gyurci previously served as Corporate Controller at MTS Systems Corporation, a global manufacturing company, from October 2017 to October 2018. Prior thereto, Mr. Gyurci served as Vice President of Financial Accounting & Reporting at Merrill Corporation, a technology company, from July 2011 to October 2017. Prior to that, Mr. Gyurci served as Managing Director of Corporate Accounting & Reporting at Northwest Airlines. He received a BA in Accounting from the University of St. Thomas in St. Paul, Minnesota, and is also a CPA (inactive status) in the state of Minnesota.

**Bill Trousdale** has served as our Vice President of Financial Planning & Analysis and Treasurer since June 2018. Previously, he served as Vice President of Corporate Finance and Treasurer at Global Eagle Entertainment from May 2016 to October 2017. Prior thereto, Mr. Trousdale worked at Laureate Education from 2009 to 2016, most recently in the role of Vice President of Financial Transformation from October 2014 to March 2016. Prior thereto, he held senior finance positions at Northwest Airlines and US Airways. Mr. Trousdale received a BS in Mechanical Engineering from MIT and an MBA from Northwestern University.

**R. Brian Davis** has served as our Vice President of Ground Operations since February 2018. He has previously held Regional Vice President positions with ASIG and acquiring entity Menzies from November 2013 to January 2018. Prior to that, Mr. Davis served in several progressive roles with Spirit Airlines from September 2003 to November 2013. Mr. Davis also held various leadership positions at US Airways, where held a position as Director Properties and Facilities. He holds a BS in Aviation Business Administration from Embry-Riddle Aeronautical University.

## [Table of Contents](#)

**Marc Becker** is a member of our board of directors. A 22-year veteran at Apollo, Mr. Becker is a Senior Partner based in New York and oversees the Firm's efforts in the payments, real estate services and building products industry verticals. Mr. Becker also chairs the Investment Committee for Apollo's U.S. and Asia real estate private equity division. Prior to joining Apollo in 1996, Mr. Becker was employed by Smith Barney Inc. within its Investment Banking division. Mr. Becker graduated cum laude with a BS in Economics from the University of Pennsylvania's Wharton School of Business. Mr. Becker serves on several corporate boards of directors, including The ADT Corporation, as Chairman, and OneMain Holdings, Inc. Previously, Mr. Becker has also served on the board of directors of Realogy, Affinion Group, Apollo Residential Mortgage, EVERTEC, National Financial Partners, Countrywide plc, SourceHOV, Metals USA, CEVA Logistics, Novitex Corp., Pacer International, Quality Distribution, Pinnacle Holdings Corp., United Agri Products and Vantium Capital. Mr. Becker is actively involved in a number of non-profit organizations and serves as a board member of the Park Avenue Synagogue and TEAK Fellowship as Chairman.

**Joshua Black** is a member of our board of directors. Mr. Black is a Principal in the Private Equity division of Apollo Global Management, Inc., having joined Apollo in 2011. Mr. Black focuses on a wide range of industries, including property and casualty insurance. Prior to joining Apollo, Mr. Black was a member of the Leveraged Finance Product Group at Goldman Sachs & Co. having worked previously in the Financial Institutions Industry Group. Mr. Black currently sits on the boards of Aspen, Tegra, Huddle House, Volotea, Somerset Partners, and Augustus Specialty. Mr. Black graduated cum laude from Princeton University with a B.A. in Religion.

**Antoine Munfakh** is a member of our board of directors. Mr. Munfakh is a Senior Partner at Apollo, having joined in 2008. Previously, Mr. Munfakh served as an Associate at the private equity firm Court Square Capital Partners, where he focused on investments into the Business & Industrial Services sectors. Prior thereto, he started his career as an Analyst in the Financial Sponsor Investment Banking group at JPMorgan, where he provided M&A and financing services in support of private equity transactions. Mr. Munfakh currently serves on the board of directors of Volotea Airlines, Direct ChassisLink Inc, Blume Global, Maxim Crane Works, Apollo Education Group and McGraw-Hill Education, Inc. He also serves on the Board of Governors of The Thirst Project, a charitable organization that builds freshwater wells in developing nations. He previously served on the board of directors of CH2M HILL Companies and Claire's Stores, Inc. Mr. Munfakh graduated summa cum laude from Duke University with a BS in Economics, where he was elected to Phi Beta Kappa. In 2018, Mr. Munfakh was selected by The M&A Advisor for their Ninth Annual Emerging Leaders Award, commonly referred to as the "40 Under 40" award.

**David Siegel** has served as our Executive Chairman since April 2018 and is also a member of our board of directors. Prior to joining Sun Country, Mr. Siegel served as the Chief Executive Officer of Ansett Worldwide Aviation Services, one of the world's 10 largest aircraft leasing companies, from April 2016 to September 2017. From January 2012 to May 2015, Mr. Siegel served as the Chief Executive Officer and President of Frontier Airlines, Inc. Prior thereto, Mr. Siegel served as Chairman and Chief Executive Officer of XOJET, Inc., a TPG Growth backed private aviation company, and as President, Chief Executive Officer and board member of US Airways Group, Inc. Mr. Siegel currently serves on the board of directors and as Chairman of Volotea, S.A. Mr. Siegel earned a MBA with honors from Harvard Business School and graduated magna cum laude from Brown University with an Sc.B. in Applied Mathematics – Economics.

**Juan Carlos Zuazua** is a member of our board of directors. Mr. Zuazua has 13 years of experience in the aviation industry and has served as the Chief Executive Officer of Viva Aerobus since 2010. Mr. Zuazua earned an MBA in Public Policy from Escuela de Graduados de Administración Pública at the Tecnológico de Monterrey.

### **Controlled Company**

We intend to apply to list the shares of our common stock offered in this offering on the NYSE. As the Apollo Stockholder will continue to control more than 50% of our combined voting power upon the completion

## Table of Contents

of this offering, we will be considered a “controlled company” for the purposes of the NYSE’s rules and corporate governance standards. As a “controlled company,” we will be permitted to, and we intend to, elect not to comply with certain corporate governance requirements, including (1) those that would otherwise require our board of directors to have a majority of independent directors, (2) those that would require that we establish a compensation committee composed entirely of independent directors and with a written charter addressing the committee’s purpose and responsibilities and (3) those that would require we have a nominating and corporate governance committee comprised entirely of independent directors with a written charter addressing the committee’s purpose and responsibilities, or otherwise ensure that the nominees for directors are determined or recommended to our board of directors by the independent members of our board of directors pursuant to a formal resolution addressing the nominations process and such related matters as may be required under the federal securities laws. Accordingly, you will not have the same protections afforded to stockholders of companies that are subject to all of these corporate governance requirements. In the event that we cease to be a “controlled company” and our shares of common stock continue to be listed on the NYSE, we will be required to comply with these provisions within the applicable transition periods.

### **Director Independence**

While we are a “controlled company” we are not required to have a majority of independent directors. As allowed under the applicable rules and regulations of the SEC and the NYSE, we intend to phase in compliance with the heightened independence requirements prior to the end of the one-year transition period after we cease to be a “controlled company.” Upon consummation of this offering, we expect our independent directors, as such term is defined by the applicable rules and regulations of the NYSE, will be Juan Carlos Zuazua and

### **Board Composition**

Upon the consummation of this offering, our board of directors will consist of ten members. We intend to avail ourselves of the “controlled company” exception under the NYSE rules, which eliminates the requirements that we have a majority of independent directors on our board of directors and that we have a compensation committee and a nominating/corporate governance committee composed entirely of independent directors. We will be required, however, to have an audit committee with one independent director during the 90-day period beginning on the date of effectiveness of the registration statement of which this prospectus is a part. After such 90-day period and until one year from the date of effectiveness of the registration statement, we will be required to have a majority of independent directors on our audit committee. Thereafter, we will be required to have an audit committee comprised entirely of independent directors.

If at any time we cease to be a “controlled company” under the NYSE rules, the board of directors will take all action necessary to comply with the applicable NYSE rules, including appointing a majority of independent directors to the board of directors and establishing certain committees composed entirely of independent directors, subject to a permitted “phase-in” period.

Upon the consummation of this offering, our board of directors will be divided into three classes. The members of each class will serve staggered, three-year terms (other than with respect to the initial terms of the Class I and Class II directors, which will be one and two years, respectively). Upon the expiration of the term of a class of directors, directors in that class will be elected for three-year terms at the annual meeting of stockholders in the year in which their term expires. Upon consummation of this offering:

- \_\_\_\_\_, \_\_\_\_\_ and \_\_\_\_\_ will be Class I directors, whose initial terms will expire at the fiscal 2021 annual meeting of stockholders;
- \_\_\_\_\_, \_\_\_\_\_ and \_\_\_\_\_ will be Class II directors, whose initial terms will expire at the fiscal 2022 annual meeting of stockholders; and
- \_\_\_\_\_, \_\_\_\_\_, \_\_\_\_\_ and \_\_\_\_\_ will be Class III directors, whose initial terms will expire at the fiscal 2023 annual meeting of stockholders.

## Table of Contents

Any additional directorships resulting from an increase in the number of directors will be distributed among the three classes so that, as nearly as possible, each class will consist of one-third of our directors. This classification of our board of directors may have the effect of delaying or preventing changes in control. At each annual meeting, our stockholders will elect the successors to one class of our directors.

The authorized number of directors may be increased or decreased by our board of directors in accordance with our certificate of incorporation. At any meeting of the board of directors, except as otherwise required by law, a majority of the total number of directors then in office will constitute a quorum for all purposes.

The Apollo Stockholder has the right, at any time until Apollo and its affiliates, including the Apollo Stockholder, no longer beneficially own at least 5% of the voting power of our outstanding common stock, to nominate a number of directors (the "Apollo Directors") comprising a percentage of the board in accordance with their beneficial ownership of the voting power of our outstanding common stock (rounded up to the nearest whole number), except that if Apollo and its affiliates, including the Apollo Stockholder, beneficially own more than 50% of the voting power of our outstanding common stock, the Apollo Stockholder will have the right to nominate a majority of the directors.

For so long as Amazon holds the 2019 Warrants or any shares of common stock issued upon exercise of the 2019 Warrants and the ATSA remains in effect, Amazon will have the right to nominate a member or an observer to our board of directors.

The restrictions imposed by federal law and DOT policy currently require that our president and at least two-thirds of the members of our board of directors and other managing officers be citizens of the United States, as defined in 49 U.S.C. § 40102(a)(15).

### **Board Committees**

Following the completion of this offering, the board committees will include an executive committee, an audit committee, a compensation committee, a nominating and corporate governance committee and a safety committee. So long as Apollo and its affiliates, including the Apollo Stockholder, beneficially own at least 5% of the voting power of our outstanding common stock, a number of directors nominated by the Apollo Stockholder that is as proportionate (rounding up to the next whole director) to the number of members of such committee as is the number of directors that the Apollo Stockholder is entitled to nominate to the number of members of our board of directors will serve on each committee of our board, subject to compliance with applicable law and the rules and regulations of the NYSE. At least two-thirds of the members of each of the executive committee, audit committee, compensation committee and nominating and corporate governance committee will be citizens of the United States, as defined in 49 U.S.C. §40102(a)(15).

#### *Executive Committee*

Following the consummation of this offering, our executive committee will consist of Jude Bricker, \_\_\_\_\_ and \_\_\_\_\_. Subject to certain exceptions, the executive committee generally may exercise all of the powers of the board of directors when the board of directors is not in session. The executive committee serves at the pleasure of our board of directors. This committee and any of its members may continue or be changed once the Apollo Stockholder no longer owns a controlling interest in us.

#### *Audit Committee*

Following the consummation of this offering, our audit committee will consist of \_\_\_\_\_, \_\_\_\_\_ and \_\_\_\_\_. We intend to avail ourselves of the "controlled company" exception under the NYSE rules, which allows us to phase in an independent audit committee. We will have an audit committee with one independent director during the 90-day period beginning on the date of effectiveness of the registration statement of which this prospectus is a part. After such 90-day period and until one year from the date of effectiveness of the registration statement, we will be required to have a majority of independent directors on our audit committee. Thereafter, we will be required to have an audit committee comprised entirely of independent directors. Our

## Table of Contents

board of directors has determined that \_\_\_\_\_ qualifies as an “audit committee financial expert” as such term is defined in Item 407(d)(5) of Regulation S-K and that \_\_\_\_\_ is independent as independence is defined in Rule 10A-3 of the Exchange Act and under the listing standards. The principal duties and responsibilities of our audit committee will be as follows:

- to prepare the annual audit committee report to be included in our annual proxy statement;
- to oversee and monitor our financial reporting process;
- to oversee and monitor the integrity of our financial statements and internal control system;
- to oversee and monitor the independence, retention, performance and compensation of our independent auditor;
- to oversee and monitor the performance, appointment and retention of our senior internal audit staff person;
- to discuss, oversee and monitor policies with respect to risk assessment and risk management;
- to oversee and monitor our compliance with legal and regulatory matters; and
- to provide regular reports to the board.

The audit committee will also have the authority to retain counsel and advisors to fulfill its responsibilities and duties and to form and delegate authority to subcommittees.

### ***Compensation Committee***

Following the consummation of this offering, our compensation committee will consist of \_\_\_\_\_, \_\_\_\_\_ and \_\_\_\_\_. The principal duties and responsibilities of the compensation committee will be as follows:

- to review, evaluate and make recommendations to the full board of directors regarding our compensation policies and programs;
- to review and approve the compensation of our chief executive officer, other officers and key employees, including all material benefits, option or stock award grants and perquisites and all material employment agreements, confidentiality and non-competition agreements;
- to review and recommend to the board of directors a succession plan for the chief executive officer and development plans for other key corporate positions as shall be deemed necessary from time to time;
- to review and make recommendations to the board of directors with respect to our incentive compensation plans and equity-based compensation plans;
- to administer incentive compensation and equity-related plans;
- to review and make recommendations to the board of directors with respect to the financial and other performance targets that must be met;
- to set and review the compensation of members of the board of directors; and
- to prepare an annual compensation committee report and take such other actions as are necessary and consistent with the governing law and our organizational documents.

We intend to avail ourselves of the “controlled company” exception under the NYSE rules which exempts us from the requirement that we have a compensation committee composed entirely of independent directors.

### ***Nominating and Corporate Governance Committee***

Following the consummation of this offering, our nominating and corporate governance committee will consist of \_\_\_\_\_, \_\_\_\_\_ and \_\_\_\_\_. The principal duties and responsibilities of the nominating and corporate governance committee will be as follows:

- to identify candidates qualified to become directors of the Company, consistent with criteria approved by our board of directors;
- to recommend to our board of directors nominees for election as directors at the next annual meeting of stockholders or a special meeting of stockholders at which directors are to be elected, as well as to recommend directors to serve on the other committees of the board;
- to recommend to our board of directors candidates to fill vacancies and newly created directorships on the board of directors;
- to identify best practices and recommend corporate governance principles, including giving proper attention and making effective responses to stockholder concerns regarding corporate governance;
- to develop and recommend to our board of directors guidelines setting forth corporate governance principles applicable to the Company; and
- to oversee the evaluation of our board of directors and senior management.

We intend to avail ourselves of the “controlled company” exception under the NYSE rules which exempts us from the requirement that we have a nominating and corporate governance committee composed entirely of independent directors.

### ***Safety Committee***

Following the consummation of this offering, our safety committee will consist of \_\_\_\_\_, \_\_\_\_\_ and \_\_\_\_\_. Our safety committee assists the board with overseeing the Company’s safety and security processes, procedures and reporting and is responsible for: (i) monitoring management’s efforts to ensure the safety of our passengers and employees; (ii) reviewing our policies, procedures and investments and monitoring our activities with respect to information security; (iii) monitoring and assisting management in creating a uniform safety culture that achieves the highest possible industry standards; and (iv) periodically reviewing all aspects of airline safety and security with management and outside experts as necessary.

### **Code of Business Conduct and Ethics**

Upon the consummation of this offering, our board of directors will adopt an amended code of business conduct and ethics that will apply to all of our directors, officers and employees and is intended to comply with the relevant listing requirements for a code of conduct as well as qualify as a “code of ethics” as defined by the rules of the SEC. The code of business conduct and ethics will contain, as it does today, general guidelines for conducting our business consistent with the highest standards of business ethics. We intend to disclose future amendments to certain provisions of our code of business conduct and ethics, or waivers of such provisions applicable to any principal executive officer, principal financial officer, principal accounting officer and controller, or persons performing similar functions, and our directors, on our website at <https://www.suncountry.com>. Following the consummation of this offering, the code of business conduct and ethics will be available on our website.

### **Board Leadership Structure and Board’s Role in Risk Oversight**

The board of directors has an oversight role, as a whole and also at the committee level, in overseeing management of its risks. The board of directors regularly reviews information regarding our credit, liquidity and operations, as well as the risks associated with each. Following the completion of this offering, the compensation

---

[Table of Contents](#)

committee of the board of directors will be responsible for overseeing the management of risks relating to employee compensation plans and arrangements and the audit committee of the board of directors will oversee the management of financial risks. While each committee will be responsible for evaluating certain risks and overseeing the management of such risks, the entire board of directors will be regularly informed through committee reports about such risks.



**EXECUTIVE COMPENSATION****Executive Summary**

The Company's goal for its executive compensation program is to utilize a pay-for-performance compensation program that is directly related to achievement of the Company's financial and strategic objectives. This program is designed to: (i) provide compensation opportunities that will allow the Company to attract and retain talented executive officers who are essential to the Company's success; (ii) provide compensation that rewards both individual and corporate performance and motivates the executive officers to achieve corporate strategic objectives; (iii) reward superior financial and operational performance in a given year, over a sustained period and expectations for the future; (iv) place compensation at risk if performance goals are not achieved; and (v) align the interests of executive officers with the long-term interests of stockholders through stock-based awards.

**Summary Compensation Table**

The following table sets forth the compensation paid or awarded to our named executive officers, or NEOs, by the Company and its affiliates for services rendered in all capacities to the Company and its affiliates in fiscal year 2019:

**Summary Compensation Table**

<b>Name and Principal Position</b>	<b>Year</b>	<b>Salary (\$)</b>	<b>Bonus (\$)</b>	<b>Option Awards (\$)(2)</b>	<b>All Other Compensation (\$)(3)</b>	<b>Total (\$)</b>
<b>Jude Bricker</b> Chief Executive Officer	2019	\$200,000	\$338,289	\$ —	\$ 28,970	\$ 567,259
<b>Dave Davis</b> President and Chief Financial Officer	2019	\$360,000	\$187,845	\$549,098	\$ 18,170	\$ 1,115,113
<b>Gregory Mays(1)</b> Chief Operating Officer	2019	\$162,500	\$156,538	\$988,950	\$ 90,038	\$1,398,026

(1) Mr. Mays was hired in June 2019.

(2) The amounts reported reflect the aggregate grant date fair value of each stock option computed in accordance with FASB ASC Topic 718. See Note 8 to our audited consolidated financial statements included elsewhere in this prospectus for the assumptions used in calculating this amount. These options were originally granted as options to purchase SCA common stock and were converted into options to purchase common stock in connection with the Reorganization Transactions. Upon the consummation of the stock split as part of the Reorganization Transactions, the exercise prices for each of the outstanding options will be appropriately adjusted.

(3) For each of our NEOs, the amounts under "All Other Compensation" for fiscal year 2019 represent the Company's contributions in respect of life insurance and our 401(k) Plan (\$11,258 for Mr. Bricker, \$12,306 for Mr. Davis and \$5,534 for Mr. Mays), annual cell phone allowance (\$720 for Mr. Bricker, \$720 for Mr. Davis and \$360 for Mr. Mays), payment for relocation expenses for Mr. Mays (\$81,123) and flight benefits under our Air Travel Plan ("ATP"). Under the ATP, certain executives, including our NEOs, receive an annual dollar value that they may use for personal travel on our flights for themselves and certain qualifying friends and family. Each one-way flight taken is valued at \$75, which is the average cost to us of a one-way flight. For fiscal 2019, each NEO received a travel bank under the ATP (\$15,000 for Mr. Bricker and \$12,500 for Messrs. Davis and Mays). As the ATP benefit utilized by the executive is taxable income to the NEOs and the Company pays such taxes on a grossed up basis, the amounts reflected under "All Other Compensation" in respect of the ATP benefit utilized were adjusted to \$16,993, \$12,306 and \$3,021 for Messrs. Bricker, Davis and Mays, respectively.

## **Employment Agreements with Named Executive Officers**

### ***Jude Bricker Employment Agreement***

We entered into a second amended and restated employment agreement with Jude Bricker to serve as Chief Executive Officer of the Company, dated as of November 7, 2018. The agreement extends for an initial term of five years from April 11, 2018 until April 11, 2023, and shall thereafter be automatically extended for successive one-year periods, unless either party provides written notice of non-renewal at least 90 days prior to the expiration of the initial term or any extended term. Pursuant to the employment agreement, Mr. Bricker's annual base salary shall be no less than \$200,000 and Mr. Bricker shall be eligible to receive a non-discretionary annual bonus equal to \$60,000, and a discretionary performance-based annual bonus with a target equal to 200% of his annual base salary.

In connection with Mr. Bricker's agreement, Mr. Bricker received an option to purchase shares of SCA common stock equal to 3% of the fully diluted total outstanding shares of SCA common stock, subject to the terms and conditions set forth in the SCA Acquisition Equity Plan and a nonqualified stock option agreement thereunder. Additionally, Mr. Bricker purchased \$6,500,000 in shares of SCA common stock at the same indicative price per share paid by the Apollo Funds, a portion of which was paid through a Company loan to Mr. Bricker in exchange for a promissory note, with a principal amount equal to \$2,500,000, which loan will be repaid in full prior to the filing of the registration statement of which this prospectus is a part.

Mr. Bricker is also entitled to travel benefits, including an annual credit of \$15,000 in his ATP account for personal travel on Company scheduled flights for him and certain qualifying friends and family. Mr. Bricker may also travel on scheduled Company flights in accordance with the Company's general employee travel policy, the cost of which is not deducted from Mr. Bricker's ATP account. Upon the earlier of April 11, 2023 or a Change in Control (as defined in the SCA Acquisition Equity Plan), Mr. Bricker's travel benefits will vest for his lifetime and be useable by Mr. Bricker for the remainder of his life.

In addition to the compensation and benefits described herein, Mr. Bricker's employment agreement also provides for compensation and benefits under specified circumstances in connection with the termination of his employment, as described below under "*Potential Payments upon Termination.*"

Mr. Bricker is subject to restrictive covenants, including non-competition during employment and for 18 months thereafter, non-solicitation of employees (including no-hire), consultants, customers and suppliers during employment and for 18 months thereafter, non-disclosure of confidential information for a perpetual period of time and non-disparagement by Mr. Bricker for a perpetual period of time.

### ***Dave Davis Employment Agreement***

Sun Country, Inc. entered into an employment agreement with Dave Davis to serve as Chief Financial Officer, effective as of April 11, 2018. Mr. Davis was thereafter promoted to President and Chief Financial Officer effective November 5, 2019. The agreement extends for a term of five years, until April 11, 2023. Pursuant to the employment agreement, Mr. Davis' annual base salary shall be no less than \$420,000 until March 31, 2019 and, beginning April 1, 2019, shall be no less than \$360,000. Mr. Davis was eligible to receive a bonus of \$168,666 for the calendar year ending December 31, 2018 and, for calendar years 2019 and thereafter, a discretionary annual bonus with a target equal to 75% of his base salary; provided, however, that for calendar year 2019, one-half of the target amount (\$135,000) shall be guaranteed and paid to Mr. Davis during the calendar year in equal installments, and during each successive year of the employment term, Mr. Davis may request, subject to approval by the chief executive officer and the board of directors, a portion of his discretionary annual bonus to become guaranteed and payable.

In connection with Mr. Davis' agreement, Mr. Davis received an option to purchase SCA common stock equal to 1.45% of the fully diluted total outstanding SCA common stock, subject to the terms and conditions set forth in the SCA Acquisition Equity Plan and a nonqualified stock option agreement thereunder. Additionally,

## Table of Contents

Mr. Davis had the opportunity to purchase SCA common stock at the same indicative price per share paid by the Apollo Funds.

Mr. Davis is also entitled to travel benefits, including an annual credit of \$12,500 in his ATP account for personal travel on Company scheduled flights for him and certain qualifying friends and family. Mr. Davis may also travel on scheduled Company flights in accordance with the Company's general employee travel policy, the cost of which is not deducted from Mr. Davis' ATP account. Upon the earlier of April 11, 2023 or a Change in Control (as defined in the SCA Acquisition Equity Plan), Mr. Davis' travel benefits will vest for his lifetime and be useable by Mr. Davis for the remainder of his life.

In addition to the compensation and benefits described herein, Mr. Davis' employment agreement also provides for compensation and benefits under specified circumstances in connection with the termination of his employment, as described below under "*Potential Payments upon Termination.*"

Mr. Davis is subject to restrictive covenants, including non-competition during employment and for 12 months thereafter, non-solicitation of employees (including no-hire), consultants, customers and suppliers during employment and for 12 months thereafter, non-disclosure of confidential information for a perpetual period of time and non-disparagement by Mr. Davis for a perpetual period of time.

### **Gregory Mays Employment Agreement**

Sun Country, Inc. entered into an employment agreement with Gregory Mays to serve as Chief Operating Officer, effective as of June 3, 2019. The agreement extends for an initial term of five years until June 3, 2024 and provides that it would thereafter be automatically extended for successive one-year periods, unless either party provides written notice of non-renewal at least 90 days prior to the expiration of the initial term or any extended term. Pursuant to the employment agreement, Mr. Mays' annual base salary shall be no less than \$300,000. Mr. Mays shall also be eligible to receive a discretionary annual bonus with a target equal to 75% of his annual base salary. Mr. Mays also received a relocation bonus of \$52,000 for his relocation to the Minneapolis, Minnesota area; however, if Mr. Mays resigns from employment for any reason prior to June 3, 2021, he must repay to the Company within 30 days of his termination a prorated portion of the relocation bonus.

In connection with Mr. Mays' agreement, Mr. Mays received an option to purchase SCA common stock equal to 1.0% of the fully diluted total outstanding SCA common stock, subject to the terms and conditions set forth in the SCA Acquisition Equity Plan and a nonqualified stock option agreement thereunder.

Mr. Mays is also entitled to travel benefits, including an annual credit of \$12,500 in his ATP account for personal travel on Company scheduled flights for him and certain qualifying friends and family. Mr. Mays may also travel on scheduled Company flights in accordance with the Company's general employee travel policy, the cost of which is not deducted from Mr. Mays' ATP account. Upon the earlier of June 3, 2024 or a Change in Control (as defined in the SCA Acquisition Equity Plan), Mr. Mays' travel benefits will vest for his lifetime and be useable by Mr. Mays for the remainder of his life.

In addition to the compensation and benefits described herein, Mr. Mays' employment agreement also provides for compensation and benefits under specified circumstances in connection with the termination of his employment, as described below under "*Potential Payments upon Termination.*"

In connection with his employment agreement, Mr. Mays is subject to restrictive covenants, including non-competition during employment and for 12 months thereafter, non-solicitation of employees (including no-hire), consultants, customers and suppliers during employment and for 12 months thereafter, non-disclosure of confidential information for a perpetual period of time and non-disparagement by Mr. Mays for a perpetual period of time.

**2019 Outstanding Equity Awards at Fiscal Year-End Table**

The following table lists each NEO's outstanding equity awards at the end of fiscal 2019.

**Outstanding Equity Awards At Fiscal 2019 Year-End**

Executive	Number of Securities Underlying Unexercised Options (#) Exercisable	Number of Securities Underlying Unexercised Options (#) Unexercisable(2)	Equity Incentive Plan Awards:	Option Exercise Price (\$)	Option Expiration Date
			Number of Securities Underlying Unexercised Options (#)(3)		
Jude Bricker	8,215	24,644	52,487	\$ 100	11/21/2028
Dave Davis(1)	3,286	9,857	20,995	\$ 100	4/17/2028
	—	2,738	4,374	\$ 286.46	11/19/2029
Gregory Mays	—	10,953	17,496	\$ 100	7/1/2029

- (1) On November 19, 2019, Mr. Davis was granted additional options with an exercise price of \$286.46 in connection with his promotion to President and Chief Financial Officer.
- (2) These options were originally granted as options to purchase SCA common stock and were converted into options to purchase common stock in connection with the Reorganization Transactions. Upon the consummation of the stock split as part of the Reorganization Transactions, the exercise prices for each of the outstanding options will be appropriately adjusted. For Messrs. Bricker and Davis, options granted in 2018 vest and become exercisable with respect to 25% of shares of common stock subject to the award on each anniversary of April 11, 2018, such that all shares will be vested on April 11, 2022, subject to the holder continuing to provide services to the Company through each such vesting date. Mr. Davis' options granted in 2019 vest and become exercisable with respect to 25% of shares of common stock subject to the award on each anniversary of November 5, 2019, such that all shares will be vested on November 5, 2023. For Mr. Mays, options vest and become exercisable with respect to 25% of shares of common stock subject to the award on each anniversary of June 3, 2019, such that all shares will be vested on June 3, 2023. All options will accelerate and vest in full upon a Change in Control (as defined in the SCA Acquisition Equity Plan).
- (3) These options were originally granted as options to purchase SCA common stock and were converted into options to purchase common stock in connection with the Reorganization Transactions. Upon the consummation of the stock split as part of the Reorganization Transactions, the exercise prices for each of the outstanding options will be appropriately adjusted. Performance-based options vest and become exercisable upon a Change in Control (as defined in the SCA Acquisition Equity Plan) subject to the satisfaction of performance-based criteria. Specifically, 33% of the performance-based options will vest and become exercisable upon a Change in Control if the Company's private equity investors achieve a MOIC of 3.0x and 100% of the performance-based options will vest and become exercisable upon a Change in Control if the Company's private equity investors achieve a MOIC of at least 5.0x. Vesting in respect of achievement between a MOIC of 3.0x and a MOIC of 5.0x is linearly interpolated. In the event that 100% of the performance-based options have not vested prior to or at the time of the effectiveness of this offering, on certain "MOIC Test Dates" (i.e., months following this offering), unvested performance-based options will vest according to the following schedule based on achievement of a multiple equal to the ratio of (i) the sum of (A) the amount of all cash consideration, plus (B) the then-current value of the shares held by the Company's private equity investors based on the volume weighted average price for the trailing ninety consecutive trading days immediately preceding the applicable MOIC Test Date to (ii) the amount of the Company's private equity investors' invested capital, provided that the amount of such invested capital shall not be reduced by distributions (the "TRMOIC"):

Months Post-IPO ("MOIC Test Date")	% of Performance-Based Options Eligible to Vest	Vested Amount Based on 3.0x TRMOIC	Vested Amount Based on 5.0x TRMOIC
12	25%	7.5%	25%
18	37.5%	11.25%	37.5%
24	50%	15.0%	50%
30	62.5%	18.75%	62.5%
36	75%	22.5%	75%

Vesting in respect of achievement between a TRMOIC of 3.0x and a TRMOIC of 5.0x will be linearly interpolated. On each MOIC Test Date, the percentage of the performance-based options that will vest on that date will be added to the percentage of the performance-based options that vested prior to the applicable MOIC Test Date, provided, however, that on any given MOIC Test Date, the total percentage of the performance-based options that may vest will not exceed the percentage shown for the applicable MOIC Test Date under the column heading "Vested Amount Based on 5.0x TRMOIC."

## Potential Payments Upon Termination

Upon a termination of employment for any reason, each NEO would be entitled to (i) any amount of annual base salary earned, but not yet paid, through the termination date, (ii) any annual bonus for the year prior to the year of termination that was earned, but not yet paid, (iii) any expenses owed to the NEO and (iv) any amount arising from the NEO's participation in, or benefits under, any employee benefit plans, programs or arrangements (including, where applicable, any death and disability benefits) (the "Accrued Obligations"). Pursuant to the terms of each NEO's option award agreement, all unvested options would automatically terminate without consideration upon a termination of employment for any reason.

Upon a termination of employment by the Company or its subsidiary without Cause (including, for Messrs. Bricker and Davis, a non-renewal by the Company or its subsidiary), or in the case of Mr. Bricker, a resignation by Mr. Bricker for Good Reason (each, a "Qualifying Termination"), each NEO would be entitled to: (i) his Accrued Obligations and (ii) continued payment of his base salary until the earlier of the 12-month (for Mr. Bricker, 18-month) anniversary of the termination date and the first date that the NEO violates any of his restrictive covenants after receipt of notice thereof and expiration of a 10-business day cure period (the "Severance Benefits"). The Severance Benefits are conditioned upon the NEO's execution of a general release of claims.

For purposes of each NEO's employment agreement, Cause shall mean: (i) the NEO's indictment for, conviction of, or plea of guilty or nolo contendere to, any (x) felony, (y) misdemeanor involving moral turpitude, or (z) other crime involving either fraud or a breach of the NEO's duty of loyalty with respect to the Company or any affiliates thereof, or any of its customers or suppliers, (ii) the NEO's failure to perform duties as reasonably directed by the board of directors (other than as a consequence of disability) after written notice thereof and failure to cure within ten business days of receipt of the written notice, (iii) the NEO's fraud, misappropriation, embezzlement (whether or not in connection with employment), or material misuse of funds or property belonging to the Company or any of its affiliates, (iv) the NEO's willful violation of the policies of the Company or any of its subsidiaries, or gross negligence in connection with the performance of his duties, after written notice thereof and failure to cure within ten business days of receipt of written notice, (v) the NEO's use of alcohol that interferes with the performance of the NEO's duties or use of illegal drugs, if either (A) the NEO fails to obtain treatment within ten business days after receipt of written notice thereof or (B) the NEO obtains treatment and, following NEO's return to work, the NEO's use of alcohol again interferes with the performance of the NEO's duties or the NEO again uses illegal drugs, (vi) the NEO's material breach of his employment agreement, and failure to cure such breach within ten business days after receipt of written notice or (vii) the NEO's breach of the confidentiality or non-disparagement provisions (excluding unintentional breaches that are cured within ten days after the NEO becomes aware of such breaches, to the extent curable) or the non-competition and non-solicitation provisions to which the NEO is subject. If, within 30 days subsequent to the NEO's termination of employment for any reason other than by the Company or its subsidiary for Cause, the Company or its subsidiary discovers facts such that the NEO's termination of employment could have been for Cause, the NEO's termination of employment will be deemed to have been for Cause for all purposes, and the NEO will be required to disgorge to the Company or its subsidiary all amounts received under his employment agreement, all equity awards or otherwise that would not have been payable to the NEO had such termination of employment been by the Company or its subsidiary for Cause.

For purposes of Mr. Bricker's employment agreement, Good Reason shall mean any of the following actions are taken by the Company without his express written consent: (i) a material reduction of Mr. Bricker's duties and responsibilities in his capacity as an employee of the Company, (ii) the relocation of Mr. Bricker's principal office location by more than 50 miles from the Minneapolis, Minnesota area (provided that the same materially increases his commute), (iii) any material breach by the Company of any material term or provision of Mr. Bricker's employment agreement or (iv) a material reduction in Mr. Bricker's annual base salary; provided, that any such event shall not constitute Good Reason unless and until Mr. Bricker shall have provided the Company with written notice thereof no later than thirty days following the initial occurrence of such event and the Company shall have failed to fully remedy such event within thirty days of receipt of such notice, and Mr. Bricker shall have terminated his employment with the Company within ten days following the expiration of such remedial period.

## [Table of Contents](#)

In the event that the payment of the severance benefits described above (together with any other payments or benefits) will result in a NEO being subject to the excise tax imposed on certain “golden parachute” arrangements under Sections 280G and 4999 of the Code, the NEOs’ employment agreements provide that such payments and benefits will be reduced to the largest amount which can be paid to the NEO without the imposition of such excise tax, but only if such reduction would result in the NEO retaining a larger after-tax benefit than if he had received all payments and been subject to the excise tax.

### **Equity Compensation Plans**

We currently maintain the SCA Acquisition Equity Plan. In connection with the Reorganization Transactions, all outstanding options to purchase SCA common stock were converted into options to purchase common stock. Upon the consummation of the stock split as part of the Reorganization Transactions, the exercise prices for each of the outstanding options will be appropriately adjusted.

#### ***2020 Omnibus Incentive Plan***

In connection with this offering, our board of directors expects to adopt, and we expect our stockholders to approve, our 2020 Omnibus Incentive Plan (the “Omnibus Incentive Plan”) to become effective in connection with the consummation of this offering. Following the adoption of the Omnibus Incentive Plan, we do not expect to issue additional options under the SCA Acquisition Equity Plan. This summary is qualified in its entirety by reference to the Omnibus Incentive Plan that is ultimately adopted by our board of directors.

*Administration.* The compensation committee of our board of directors will administer the Omnibus Incentive Plan. The compensation committee will have the authority to determine the terms and conditions of any agreements evidencing any awards granted under the Omnibus Incentive Plan and to adopt, alter and repeal rules, guidelines and practices relating to the Omnibus Incentive Plan. The compensation committee will have full discretion to administer and interpret the Omnibus Incentive Plan and to adopt such rules, regulations and procedures as it deems necessary or advisable and to determine, among other things, the time or times at which the awards may be exercised and whether and under what circumstances an award may be exercised.

*Eligibility.* Any current or prospective employees, directors, officers, consultants or advisors of the Company or its affiliates who are selected by the compensation committee will be eligible for awards under the Omnibus Incentive Plan. The compensation committee will have the sole and complete authority to determine who will be granted an award under the Omnibus Incentive Plan.

*Number of Shares Authorized.* Pursuant to the Omnibus Incentive Plan, we have reserved an aggregate of \_\_\_\_\_ shares of our common stock for issuance of awards to be granted thereunder. No more than \_\_\_\_\_ shares of our common stock may be issued with respect to incentive stock options under the Omnibus Incentive Plan. The maximum grant date fair value of cash and equity awards that may be awarded to a non-employee director under the Omnibus Incentive Plan during any one fiscal year, taken together with any cash fees paid to such non-employee director during such fiscal year, will be \$ \_\_\_\_\_, provided that the foregoing limitation will not apply to any awards issued to a non-employee director in respect of any one-time initial equity grant upon a non-employee director’s appointment to the board of directors. If any award granted under the Omnibus Incentive Plan expires, terminates, or is canceled or forfeited without being settled, vested or exercised, shares of our common stock subject to such award will again be made available for future grants. Any shares that are surrendered or tendered to pay the exercise price of an award or to satisfy withholding taxes owed, or any shares reserved for issuance, but not issued, with respect to settlement of a stock appreciation right, will not again be available for grants under the Omnibus Incentive Plan. Shares of common stock withheld by, or otherwise remitted to the Company to satisfy a participant’s tax withholding obligations upon the lapse of restrictions on, or settlement of, an award, other than a stock option or SAR, will again be available for awards under the share pool.

*Change in Capitalization.* If there is a change in our capitalization in the event of a stock or extraordinary cash dividend, recapitalization, stock split, reverse stock split, reorganization, merger, consolidation, split-up,

## Table of Contents

split-off, spin-off, combination, repurchase or exchange of shares of our common stock or other relevant change in capitalization or applicable law or circumstances, such that the compensation committee determines that an adjustment to the terms of the Omnibus Incentive Plan (or awards thereunder) is necessary or appropriate, then the compensation committee shall make adjustments in a manner that it deems equitable. Such adjustments may be to the number of shares reserved for issuance under the Omnibus Incentive Plan, the number of shares covered by awards then outstanding under the Omnibus Incentive Plan, the limitations on awards under the Omnibus Incentive Plan, the exercise price of outstanding options, or any applicable performance measures (including, without limitation, performance conditions and performance periods), or such other equitable substitution or adjustments as the compensation committee may determine appropriate.

*Awards Available for Grant.* The compensation committee may grant awards of non-qualified stock options, incentive (qualified) stock options, stock appreciation rights (“SARs”), restricted stock awards, restricted stock units, other stock-based awards, other cash-based awards or any combination of the foregoing. Awards may be granted under the Omnibus Incentive Plan in assumption of, or in substitution for, outstanding awards previously granted by an entity acquired by the Company or with which the Company combines, which are referred to herein as “Substitute Awards.” All awards granted under the Omnibus Incentive Plan will vest and become exercisable in such manner and on such date or dates or upon such event or events as determined by the compensation committee.

*Stock Options.* The compensation committee will be authorized to grant options to purchase shares of our common stock that are either “qualified,” meaning they are intended to satisfy the requirements of Section 422 of the Code for incentive stock options, or “non-qualified,” meaning they are not intended to satisfy the requirements of Section 422 of the Code. All options granted under the Omnibus Incentive Plan shall be non-qualified unless the applicable award agreement expressly states that the option is intended to be an incentive stock option. Options granted under the Omnibus Incentive Plan will be subject to the terms and conditions established by the compensation committee. Under the terms of the Omnibus Incentive Plan, the exercise price of the options will not be less than the fair market value (or 110% of the fair market value in the case of a qualified option granted to a 10% stockholder) of our common stock at the time of grant (except with respect to Substitute Awards). Options granted under the Omnibus Incentive Plan will be subject to such terms, including the exercise price and the conditions and timing of exercise, as may be determined by the compensation committee and specified in the applicable award agreement. The maximum term of an option granted under the Omnibus Incentive Plan will be ten years from the date of grant (or five years in the case of a qualified option granted to a 10% stockholder), provided that if the term of a non-qualified option would expire at a time when trading in the shares of our common stock is prohibited by the Company’s insider trading policy, the option’s term shall be extended automatically until the 30th day following the expiration of such prohibition (as long as such extension shall not violate Section 409A of the Code). Payment in respect of the exercise of an option may be made in cash, by check, by cash equivalent and/or by delivery of shares of our common stock valued at the fair market value at the time the option is exercised, or any combination of the foregoing, provided that such shares are not subject to any pledge or other security interest, or by such other method as the compensation committee may permit in its sole discretion, including (i) by delivery of other property having a fair market value equal to the exercise price and all applicable required withholding taxes, (ii) if there is a public market for the shares of our common stock at such time, by means of a broker-assisted cashless exercise mechanism or (iii) by means of a “net exercise” procedure effected by withholding the minimum number of shares otherwise deliverable in respect of an option that are needed to pay the exercise price and all applicable required withholding taxes. In all events of cashless or net exercise, any fractional shares of common stock will be settled in cash. If, on the last day of an option period, the fair market value of the common stock exceeds the exercise price, the participant has not exercised the option, and the option has not previously expired, such option will be deemed exercised by the participant on such last day by means of a “net exercise” procedure as described above.

*Stock Appreciation Rights.* The compensation committee will be authorized to award SARs under the Omnibus Incentive Plan. SARs will be subject to the terms and conditions established by the compensation



## Table of Contents

committee. A SAR is a contractual right that allows a participant to receive, in the form of either cash, shares or any combination of cash and shares, the appreciation, if any, in the value of a share over a certain period of time. An option granted under the Omnibus Incentive Plan may include SARs, and SARs may also be awarded to a participant independent of the grant of an option. SARs granted in connection with an option shall be subject to terms similar to the option corresponding to such SARs, including with respect to vesting and expiration. Except as otherwise provided by the compensation committee (in the case of Substitute Awards or SARs granted in tandem with previously granted options), the strike price per share of our common stock underlying each SAR shall not be less than 100% of the fair market value of such share, determined as of the date of grant and the maximum term of a SAR granted under the Omnibus Incentive Plan will be ten years from the date of grant. If on the last day of the option period (or in the case of a SAR independent of an option, the SAR period), the fair market value exceeds the applicable strike price, the participant has not exercised the SAR or the corresponding option (if applicable) has not previously expired, such SAR will be deemed to have been exercised by the participant on such last day and the Company will make the appropriate payment therefor.

*Restricted Stock.* The compensation committee will be authorized to grant restricted stock under the Omnibus Incentive Plan, which will be subject to the terms and conditions established by the compensation committee. Restricted stock is common stock that is generally non-transferable and is subject to other restrictions determined by the compensation committee for a specified period. Any accumulated dividends will be payable at the same time that the underlying restricted stock vests.

*Restricted Stock Unit Awards.* The compensation committee will be authorized to grant restricted stock unit awards, which will be subject to the terms and conditions established by the compensation committee. A restricted stock unit award, once vested, may be settled in a number of shares of our common stock equal to the number of units earned, in cash equal to the fair market value of the number of shares of our common stock earned in respect of such restricted stock unit award or in a combination of the foregoing, at the election of the compensation committee. Restricted stock units may be settled at the expiration of the period over which the units are to be earned or at a later date selected by the compensation committee. To the extent provided in an award agreement, the holder of outstanding restricted stock units shall be entitled to be credited with dividend equivalent payments upon the payment by us of dividends on shares of our common stock, either in cash or, at the sole discretion of the compensation committee, in shares of our common stock having a fair market value equal to the amount of such dividends (or a combination of cash and shares), and interest may, at the sole discretion of the compensation committee, be credited on the amount of cash dividend equivalents at a rate and subject to such terms as determined by the compensation committee, which accumulated dividend equivalents (and interest thereon, if applicable) shall be payable at the same time that the underlying restricted stock units are settled.

*Other Stock-Based Awards.* The compensation committee will be authorized to grant awards of unrestricted shares of our common stock, rights to receive grants of awards at a future date, other awards denominated in shares of our common stock, or awards that provide for cash payments based in whole or in part on the value of our common stock under such terms and conditions as the compensation committee may determine and as set forth in the applicable award agreement.

*Effect of a Change in Control.* Unless otherwise provided in an award agreement, or any applicable employment, consulting, change in control, severance or other agreement between us and a participant, in the event of a change in control (as defined in the Omnibus Incentive Plan), if the acquirer or successor company in a change in control has agreed to provide for the substitution, assumption, exchange or other continuation of awards granted pursuant to the Omnibus Incentive Plan, then, if a participant's employment or service is terminated by us other than for cause (and other than due to death or disability) within the 12-month period following a change in control, then the compensation committee may provide that (i) all then-outstanding options and SARs held by such participant will become immediately exercisable as of such participant's date of termination with respect to all of the shares subject to such option or SAR; and/or (ii) the restricted period (and any other conditions) shall expire as of such participant's date of termination with respect to all of the then-



## Table of Contents

outstanding shares of restricted stock or restricted stock units held by such participant (including without limitation a waiver of any applicable performance goals); provided that with respect to any award whose vesting or exercisability is otherwise subject to the achievement of performance conditions, the portion of such award that shall become fully vested and immediately exercisable shall be based on the assumed achievement of actual or target performance as determined by the compensation committee. If the acquirer or successor company in a change in control has not agreed to provide for the substitution, assumption, exchange or other continuation of awards granted pursuant to the Omnibus Incentive Plan, then the compensation committee may provide that all options and SARs held by such participant shall become immediately exercisable with respect to 100% of the shares subject to such options and SARs, and the restricted period (and any other conditions) shall expire immediately with respect to 100% of the shares of restricted stock and RSUs and any other awards (other than any other cash-based awards) held by such participant (including a waiver of any applicable performance conditions); provided, that if the vesting or exercisability of any award would otherwise be subject to the achievement of performance conditions, the portion of such award that will become fully vested and immediately exercisable will be based on the assumed achievement of actual or target performance as determined by the compensation committee. In addition, the compensation committee may in its discretion and upon at least ten days' notice to the affected persons, cancel any outstanding award and pay the holders, in cash, securities or other property (including of the acquiring or successor company), or any combination thereof, the value of such awards based upon the price per share of the Company's common stock received or to be received by other stockholders of the Company in connection with the transaction (it being understood that any option or SAR having a per-share exercise price or strike price equal to, or in excess of, the fair market value (as of the date specified by the compensation committee) of a share of the Company's common stock subject thereto may be canceled and terminated without payment or consideration therefor). Notwithstanding the above, the compensation committee shall exercise such discretion over the timing of settlement of any award subject to Section 409A of the Code at the time such award is granted.

*Nontransferability.* Each award may be exercised during the participant's lifetime by the participant or, if permissible under applicable law, by the participant's guardian or legal representative. No award may be assigned, alienated, pledged, attached, sold or otherwise transferred or encumbered by a participant other than by will or by the laws of descent and distribution unless the compensation committee permits the award to be transferred to a permitted transferee (as defined in the Omnibus Incentive Plan).

*Amendment.* The Omnibus Incentive Plan will have a term of ten years. The board of directors may amend, suspend or terminate the Omnibus Incentive Plan at any time, subject to stockholder approval if necessary to comply with any tax, exchange rules, or other applicable regulatory requirement. No amendment, suspension or termination will materially and adversely affect the rights of any participant or recipient of any award without the consent of the participant or recipient.

The compensation committee may, to the extent consistent with the terms of any applicable award agreement, waive any conditions or rights under, amend any terms of, or alter, suspend, discontinue, cancel or terminate, any award theretofore granted or the associated award agreement, prospectively or retroactively; provided that any such waiver, amendment, alteration, suspension, discontinuance, cancellation or termination that would materially and adversely affect the rights of any participant with respect to any award theretofore granted will not to that extent be effective without the consent of the affected participant; and provided further that, without stockholder approval, (i) no amendment or modification may reduce the exercise price of any option or the strike price of any SAR, (ii) the compensation committee may not cancel any outstanding option and replace it with a new option (with a lower exercise price) or cancel any SAR and replace it with a new SAR (with a lower strike price) or, in each case, with another award or cash in a manner that would be treated as a repricing (for compensation disclosure or accounting purposes), (iii) the compensation committee may not take any other action considered a repricing for purposes of the stockholder approval rules of the applicable securities exchange on which our common shares are listed and (iv) the compensation committee may not cancel any outstanding option or SAR that has a per-share exercise price or strike price (as applicable) at or above the fair market value of a share of our common stock on the date of cancellation and pay any consideration to the holder thereof.

## Table of Contents

However, stockholder approval is not required with respect to clauses (i), (ii), (iii) and (iv) above with respect to certain adjustments on changes in capitalization.

*Clawback/Forfeiture.* Awards may be subject to clawback or forfeiture to the extent required by applicable law (including, without limitation, Section 304 of the Sarbanes-Oxley Act and Section 954 of the Dodd-Frank Act) and/or the rules and regulations of the NYSE or other applicable securities exchange, or if so required pursuant to a written policy adopted by the Company or the provisions of an award agreement.

*Whistleblower Acknowledgments.* Nothing in the Omnibus Incentive Plan or award agreement will (i) prohibit a participant from making reports of possible violations of federal law or regulation to any governmental agency or entity in accordance with the provisions of and rules promulgated under Section 21F of the Exchange Act or Section 806 of the Sarbanes-Oxley Act, or of any other whistleblower protection provisions of federal law or regulation, or (ii) require prior approval by the Company or any of its affiliates of any reporting described in clause (i).

### *U.S. Federal Income Tax Consequences*

*The following is a general summary of the material U.S. federal income tax consequences of the grant, exercise and vesting of awards under the Omnibus Incentive Plan and the disposition of shares acquired pursuant to the exercise or settlement of such awards and is intended to reflect the current provisions of the Code and the regulations thereunder. This summary is not intended to be a complete statement of applicable law, nor does it address foreign, state, local or payroll tax considerations. This summary assumes that all awards described in the summary are exempt from, or comply with, the requirement of Section 409A of the Code. Moreover, the U.S. federal income tax consequences to any particular participant may differ from those described herein by reason of, among other things, the particular circumstances of such participant.*

*Stock Options.* Holders of incentive stock options will generally incur no federal income tax liability at the time of grant or upon vesting or exercise of those options. However, the spread at exercise will be an “item of tax preference,” which may give rise to “alternative minimum tax” liability for the taxable year in which the exercise occurs. If the holder does not dispose of the shares before the later of two years following the date of grant and one year following the date of exercise, the difference between the exercise price and the amount realized upon disposition of the shares will constitute long-term capital gain or loss, as the case may be. Assuming the holding period is satisfied, no deduction will be allowed to us for federal income tax purposes in connection with the grant or exercise of the incentive stock option. If, within two years following the date of grant or within one year following the date of exercise, the holder of shares acquired through the exercise of an incentive stock option disposes of those shares, the participant will generally realize taxable compensation at the time of such disposition equal to the difference between the exercise price and the lesser of the fair market value of the share on the date of exercise or the amount realized on the subsequent disposition of the shares, and that amount will generally be deductible by us for federal income tax purposes, subject to the possible limitations on deductibility under Sections 280G and 162(m) of the Code for compensation paid to executives designated in those Sections. Finally, if an incentive stock option becomes first exercisable in any one year for shares having an aggregate value in excess of \$100,000 (based on the grant date value), the portion of the incentive stock option in respect of those excess shares will be treated as a non-qualified stock option for federal income tax purposes.

No income will be realized by a participant upon grant or vesting of an option that does not qualify as an incentive stock option (“a non-qualified stock option”). Upon the exercise of a non-qualified stock option, the participant will recognize ordinary compensation income in an amount equal to the excess, if any, of the fair market value of the underlying exercised shares over the option exercise price paid at the time of exercise, and the participant’s tax basis will equal the sum of the compensation income recognized and the exercise price. We will be able to deduct this same excess amount for U.S. federal income tax purposes, but such deduction may be limited under Sections 280G and 162(m) of the Code for compensation paid to certain executives designated in those Sections. In the event of a sale of shares received upon the exercise of a non-qualified stock option, any

## [Table of Contents](#)

appreciation or depreciation after the exercise date generally will be taxed as capital gain or loss and will be long-term gain or loss if the holding period for such shares is more than one year.

*SARs.* No income will be realized by a participant upon grant or vesting of a SAR. Upon the exercise of a SAR, the participant will recognize ordinary compensation income in an amount equal to the fair market value of the payment received in respect of the SAR. We will be able to deduct this same amount for U.S. federal income tax purposes, but such deduction may be limited under Sections 280G and 162(m) of the Code for compensation paid to certain executives designated in those Sections.

*Restricted Stock.* A participant will not be subject to tax upon the grant of an award of restricted stock unless the participant otherwise elects to be taxed at the time of grant pursuant to Section 83(b) of the Code. On the date an award of restricted stock becomes transferable or is no longer subject to a substantial risk of forfeiture (i.e., the vesting date), the participant will have taxable compensation equal to the difference between the fair market value of the shares on that date over the amount the participant paid for such shares, if any, unless the participant made an election under Section 83(b) of the Code to be taxed at the time of grant. If the participant made an election under Section 83(b), the participant will have taxable compensation at the time of grant equal to the difference between the fair market value of the shares on the date of grant over the amount the participant paid for such shares, if any. If the election is made, the participant will not be allowed a deduction for amounts subsequently required to be returned to us. (Special rules apply to the receipt and disposition of restricted shares received by officers and directors who are subject to Section 16(b) of the Exchange Act). We will be able to deduct, at the same time as it is recognized by the participant, the amount of taxable compensation to the participant for U.S. federal income tax purposes, but such deduction may be limited under Sections 280G and 162(m) of the Code for compensation paid to certain executives designated in those Sections.

*Restricted Stock Units.* A participant will not be subject to tax upon the grant or vesting of a restricted stock unit award. Rather, upon the delivery of shares or cash pursuant to a restricted stock unit award, the participant will have taxable compensation equal to the fair market value of the number of shares (or the amount of cash) the participant actually receives with respect to the award. We will be able to deduct the amount of taxable compensation to the participant for U.S. federal income tax purposes, but the deduction may be limited under Sections 280G and 162(m) of the Code for compensation paid to certain executives designated in those Sections.

*Section 162(m).* In general, Section 162(m) of the Code denies a publicly held corporation a deduction for U.S. federal income tax purposes for compensation in excess of \$1,000,000 per year per person to the executives designated in Section 162(m) of the Code, including, but not limited to, its chief executive officer, chief financial officer and the next three highly compensated executives of such corporation whose compensation is required to be disclosed in its proxy statement. The existing regulations under Section 162(m) may provide us, as a new publicly traded company, transition relief from the \$1,000,000 deduction limitation until our first stockholders meeting at which directors are elected in the year that is three years following the closing of this offering. However, the IRS has requested comments from interested stakeholders on the application of Section 162(m) to new publicly traded companies in light of the Tax Cuts and Jobs Act, which was passed at the end of 2017, and which made significant changes to Section 162(m). It is possible that the IRS might narrow or eliminate the transition relief. In addition, we reserve the right to award compensation as to which a deduction may be limited under Section 162(m) where we believe it is appropriate to do so.

[Table of Contents](#)**Director Compensation****2019 Director Compensation**

During 2019, none of the members of our board of directors received any compensation from the Company for their services on the board, except as set forth below.

<u>Name</u>	<u>Fees Earned or Paid in Cash (\$)</u>	<u>Stock Awards (\$)</u>	<u>Option Awards (\$)(1)</u>	<u>All Other Compensation (\$)(2)</u>	<u>Total (\$)</u>
<b>David Siegel</b>	\$ 60,000	\$300,000	\$ —	\$ 1,958	\$361,958
<b>Juan Carlos ZuaZua</b>	\$ 25,000	\$ —	\$11,280	\$ —	\$ 36,280

- (1) The amounts reported reflect the aggregate grant date fair value of each stock option computed in accordance with FASB ASC Topic 718. See Note 8 of the consolidated financial statements included elsewhere in this prospectus for the assumptions used in calculating this amount. These options were originally granted as options to purchase SCA common stock and were converted into options to purchase common stock in connection with the Reorganization Transactions. Upon the consummation of the stock split as part of the Reorganization Transactions, the exercise prices for each of the outstanding options will be appropriately adjusted.
- (2) The amounts under "All Other Compensation" represent the Company's contributions in respect of life insurance and our 401(k) Plan. The value of this benefit is reported as taxable income with taxes on such income paid for by the Company.

## CERTAIN RELATIONSHIPS AND RELATED PARTY TRANSACTIONS

Other than compensation arrangements for our executive officers and directors (see “*Executive Compensation*” for a discussion of compensation arrangements for our named executive officers and directors) and the transactions discussed below, there were no transactions, to which we were a party or will be a party, in which:

- the amounts involved exceeded or will exceed \$120,000; and
- any of our directors, executive officers or holders of more than 5% of our capital stock, or any member of the immediate family of the foregoing persons, had or will have a direct or indirect material interest.

### **Policies and Procedures for Related Party Transactions**

Upon the consummation of this offering, we will adopt a written Related Person Transaction Policy (the “policy”), which will set forth our policy with respect to the review, approval, ratification and disclosure of all related person transactions by our audit committee. In accordance with the policy, our audit committee will have overall responsibility for implementation of and compliance with the policy.

For purposes of the policy, a “related person transaction” is a transaction, arrangement or relationship (or any series of similar transactions, arrangements or relationships) in which we were, are or will be a participant and the amount involved exceeded, exceeds or will exceed \$120,000 and in which any related person (as defined in the policy) had, has or will have a direct or indirect material interest. A “related person transaction” does not include any employment relationship or transaction involving an executive officer and any related compensation resulting solely from that employment relationship that has been reviewed and approved by our board of directors or audit committee.

The policy will require that notice of a proposed related person transaction be provided to our legal department prior to entry into such transaction. If our legal department determines that such transaction is a related person transaction, the proposed transaction will be submitted to our audit committee for consideration. Under the policy, our audit committee may approve only those related person transactions that are in, or not inconsistent with, our best interests and the best interests of our stockholders. In the event that we become aware of a related person transaction that has not been previously reviewed, approved or ratified under the policy and that is ongoing or is completed, the transaction will be submitted to the audit committee so that it may determine whether to ratify, rescind or terminate the related person transaction.

The policy will also provide that the audit committee review certain previously approved or ratified related person transactions that are ongoing to determine whether the related person transaction remains in our best interests and the best interests of our stockholders. Additionally, we will make periodic inquiries of directors and executive officers with respect to any potential related person transaction of which they may be a party or of which they may be aware.

### **The Reorganization Transactions**

Prior to this offering, the Apollo Funds engaged in a series of transactions to form a new holding company, which is the Apollo Stockholder, that acquired all of the outstanding shares of SCA common stock held by the Apollo Funds and acquired and immediately exercised all of the warrants to purchase SCA common stock that were held by the Apollo Funds. As a result, the Apollo Stockholder owned 2,400,000 shares of SCA common stock, which represented approximately 96.9% of the outstanding SCA common stock.

On January 31, 2020, SCA Acquisition Holdings, LLC was converted into a Delaware corporation pursuant to a statutory conversion and changed its name to Sun Country Airlines Holdings, Inc. In connection with our conversion to a corporation, all of the outstanding shares of SCA common stock were converted into shares of

## Table of Contents

our common stock, the outstanding warrants held by Amazon to purchase shares of SCA common stock were converted into warrants to purchase shares of our common stock and all of the outstanding options to purchase shares of SCA common stock were converted into options to purchase shares of our common stock. As a result of the conversion, Sun Country Airlines Holdings, Inc. continued to hold all property and assets of SCA Acquisition Holdings, LLC and assumed all of the debts and obligations of SCA Acquisition Holdings, LLC, the members of the board of directors of SCA Acquisition Holdings, LLC became the members of the board of directors of Sun Country Airlines Holdings, Inc. and the officers of SCA Acquisition Holdings, LLC became the officers of Sun Country Airlines Holdings, Inc.

Prior to the completion of this offering, we will effect a \_\_\_\_\_ for 1 stock split of our common stock, with exercise prices for our outstanding warrants and options appropriately adjusted. Following the stock split but before the completion of this offering, we will have an aggregate of \_\_\_\_\_ shares of our common stock outstanding, warrants to purchase an aggregate of \_\_\_\_\_ shares of our common stock outstanding at an exercise price of \$ \_\_\_\_\_ per share, approximately \_\_\_\_\_ % of which have vested, and options to purchase an aggregate of \_\_\_\_\_ shares of our common stock outstanding at a weighted average exercise price of \$ \_\_\_\_\_ per share.

In this prospectus, we refer to the transactions described above as the “Reorganization Transactions.”

### **Transactions with Executive Officers and Directors**

On April 11, 2018, Jude Bricker, our Chief Executive Officer and a director, purchased 65,000 shares of SCA common stock at a purchase price of \$100 per share. In addition, Mr. Bricker borrowed \$2,500,000 from SCA Acquisition Holdings, LLC pursuant to a promissory note issued on April 20, 2018. The loan will be repaid in full prior to the filing of the registration statement of which this prospectus is a part.

On April 11, 2018, David Siegel, our Executive Chairman and a director, purchased 10,000 shares of SCA common stock at a purchase price of \$100 per share. In addition, Mr. Siegel borrowed \$1,000,000 from SCA Acquisition Holdings, LLC pursuant to a promissory note issued on April 20, 2018. The loan will be repaid in full prior to the filing of the registration statement of which this prospectus is a part. On August 1, 2019, SCA Acquisition Holdings, LLC issued 3,000 shares of SCA common stock to Mr. Siegel as compensation for certain diligence services in connection with our acquisition by the Apollo Funds.

### **EETC Financing**

An affiliate of Apollo, Apollo Global Securities, LLC, acted as co-manager in connection with the 2019-01 EETC financing and received customary placement agent fees of approximately \$198,870.

### **Stockholders Agreement**

On May 16, 2018, SCA Acquisition Holdings, LLC entered into the Amended and Restated Stockholders’ Agreement (the “Stockholders Agreement”) with AP VIII (SCA Stock AIV), LLC (“Stock AIV”) and the co-investors and other stockholders party thereto, which imposes certain transfer restrictions and provides for the Company’s right to repurchase any common stock proposed to be sold by the holders party thereto and the Company’s right to repurchase any common stock held by such holders in the event they are terminated from their employment or consultancy with the Company. The Stockholders Agreement also provides Stock AIV with certain drag-along rights and the other holders party thereto with certain tag-along rights in the event of a disposition of the shares of common stock held by them. On January 31, 2020, in connection with the Reorganization Transactions, the Stockholders Agreement was amended and restated to reflect the Apollo Stockholder’s acquisition of SCA common stock from Stock AIV and our conversion to a corporation.

We intend to further amend and restate the Stockholders Agreement in connection with this offering to eliminate certain transfer restrictions and the repurchase, drag-along and tag-along rights and to provide that the Apollo Stockholder has the right, at any time until Apollo and its affiliates, including the Apollo Stockholder, no longer beneficially own at least 5% of the voting power of our outstanding common stock, to nominate a number

## [Table of Contents](#)

of directors comprising a percentage of the board in accordance with its beneficial ownership of the voting power of our outstanding common stock (rounded up to the nearest whole number). See “*Management—Board Composition.*”

### **Registration Rights Agreement**

Prior to the consummation of this offering, we intend to enter into a registration rights agreement with the Apollo Stockholder and certain of our existing holders of our common stock prior to this offering (collectively, the “Holders”), pursuant to which the Apollo Stockholder will be entitled to demand the registration of the sale of the \_\_\_\_\_ shares of common stock it beneficially owns and all of the Holders will be entitled to piggy-back registration rights with respect to an aggregate of \_\_\_\_\_ shares of common stock. Any sales in the public market of any common stock registrable pursuant to the registration rights agreement could adversely affect prevailing market prices of our common stock. See “*Risk Factors—Risks Related to this Offering and Ownership of our Common Stock—Future sales of our common stock in the public market or the perception in the public market that such sales may occur, could reduce our stock price*” and “*Shares Eligible for Future Sale.*”

### **Amazon Registration Rights Agreement**

In connection with this offering, we will enter into a registration rights agreement with Amazon, pursuant to which Amazon will be entitled to certain piggy-back registration rights with respect to the \_\_\_\_\_ shares of common stock issuable upon exercise of the 2019 Warrants. To the extent Amazon exercises the 2019 Warrants for shares of common stock, it will dilute the ownership interests of our then-existing stockholders and reduce our earnings per share. In addition, any sales in the public market of any common stock issuable upon the exercise of the 2019 Warrants could adversely affect prevailing market prices of our common stock. See “*Risk Factors—Risks Related to this Offering and Ownership of our Common Stock—Future sales of our common stock in the public market or the perception in the public market that such sales may occur, could reduce our stock price*” and “*Shares Eligible for Future Sale.*”

**PRINCIPAL AND SELLING STOCKHOLDERS**

The following table sets forth the beneficial ownership of our common stock as of \_\_\_\_\_, 2020, after giving effect to the stock split as part of the Reorganization Transactions, by:

- each person, or group of affiliated persons, who we know to beneficially own more than 5% of either class of our common stock;
- each of our named executive officers for fiscal year 2019;
- each of our current directors;
- all of our current directors and executive officers as a group; and
- the selling stockholder.

Beneficial ownership is determined in accordance with the rules of the SEC. These rules generally attribute beneficial ownership of securities to persons who possess sole or shared voting power or investment power with respect to such securities. Except as otherwise indicated, all persons listed below have sole voting and investment power with respect to the shares beneficially owned by them, subject to applicable community property laws. Unless otherwise indicated, the address of each person or entity named in the table below is 2005 Cargo Road, Minneapolis, MN 55450.

	Shares of Common Stock Beneficially Owned Before the Offering		Shares of Common Stock Being Offered	Shares of Common Stock Beneficially Owned After the Offering assuming underwriters' option is not exercised		Shares of Common Stock Beneficially Owned After the Offering assuming underwriters' option is exercised	
	Number	Percent		Number	Percent	Number	Percent
<b>5% Stockholders</b>							
SCA Horus Holdings, LLC(1)							
<b>Named Executive Officers and Directors</b>							
Jude Bricker(2)							
Dave Davis(3)							
Gregory Mays(4)							
Marc Becker(5)							
Joshua Black(1)(5)							
Antoine Munfakh(1)(5)							
David Siegel(5)							
Juan Carlos Zuazua							
All current directors and executive officers as a group ( _____ persons)							

\* Less than 1%.

(1) SCA Horus Holdings, LLC (the "Apollo Stockholder") is managed by a board of directors consisting of Marc Becker, Joshua Black and Antoine Munfakh. Messrs. Becker, Black and Munfakh each disclaim any beneficial ownership of the shares of common stock held by the Apollo Stockholder except to the extent of their pecuniary interest therein. The address for the Apollo Stockholder is 9 West 57th Street, 43rd Floor, New York, New York 10019.

(2) Number of shares of common stock beneficially owned includes \_\_\_\_\_ shares of common stock issuable upon the exercise of options within 60 days.

(3) Number of shares of common stock beneficially owned includes \_\_\_\_\_ shares of common stock issuable upon the exercise of options within 60 days.

(4) Number of shares of common stock beneficially owned includes \_\_\_\_\_ shares of common stock issuable upon the exercise of options within 60 days.

(5) Marc Becker, Joshua Black and Antoine Munfakh are affiliated with Apollo Management, L.P. and its affiliated investment managers and advisors. Each of Messrs. Becker, Black and Munfakh disclaims beneficial ownership of the shares of common stock held by the Apollo Stockholder except to the extent of his pecuniary interest therein. The address of each of Messrs. Becker, Black and Munfakh is 9 West 57th Street, 43rd Floor, New York, New York 10019.

(6) Number of shares of common stock beneficially owned includes \_\_\_\_\_ shares of common stock issuable upon the exercise of options within 60 days.



## DESCRIPTION OF CAPITAL STOCK

*The following is a description of the material terms of our certificate of incorporation and bylaws, each of which will become effective prior to the consummation of this offering, and of specific provisions of Delaware law. The following description is intended as a summary only and is qualified in its entirety by reference to our certificate of incorporation, our bylaws and the DGCL.*

### General

Upon the closing of this offering and the filing of our amended and restated certificate of incorporation that will become effective prior to the closing of this offering, our capital stock will consist of \_\_\_\_\_ authorized shares, of which \_\_\_\_\_ shares, par value \$0.01 per share, will be designated as “common stock” and \_\_\_\_\_ shares, par value \$0.01 per share, will be designated as “preferred stock.” As of December 31, 2019, after giving effect to the Reorganization Transactions, there would have been \_\_\_\_\_ shares of common stock outstanding and no shares of preferred stock outstanding.

### Common Stock

*Voting Rights.* The holders of our common stock are entitled to one vote per share on all matters submitted for action by the stockholders generally.

*Dividend Rights.* Subject to any preferential rights of any then outstanding preferred stock, all shares of our common stock are entitled to share equally in any dividends our board of directors may declare from legally available sources.

*Liquidation Rights.* Upon our liquidation, dissolution or winding up, whether voluntary or involuntary, after payment in full of the amounts required to be paid to holders of any the outstanding preferred stock, all shares of our common stock are entitled to share equally in the assets available for distribution to stockholders after payment of all of our prior obligations.

*Other Matters.* Holders of our common stock have no preemptive or conversion rights, and our common stock is not subject to further calls or assessments by us. There are no redemption or sinking fund provisions applicable to our common stock.

### Preferred Stock

Pursuant to our certificate of incorporation, shares of preferred stock are issuable from time to time, in one or more series, with the designations, voting rights (full, limited or no voting rights), powers, preferences and relative, participating, optional or other special rights (if any), and any qualifications, limitations or restrictions thereof, of each series as our board of directors from time to time may adopt by resolution (and without further stockholder approval). Each series of preferred stock will consist of an authorized number of shares as will be stated and expressed in the certificate of designations providing for the creation of the series.

### Warrants

In connection with the ATSA, we issued warrants (the “2019 Warrants”) to purchase an aggregate of 502,028 shares of SCA common stock at an exercise price of \$286.46 per share to Amazon. In connection with the Reorganization Transactions, the 2019 Warrants were converted into warrants to purchase an aggregate of \_\_\_\_\_ shares of our common stock and the exercise price was adjusted to \$ \_\_\_\_\_ per share. 1.0% of the ATSA Warrants vested upon issuance of the warrants and incremental tranches will vest upon certain milestones of aggregate global payments by Amazon or its affiliates to the Company or its affiliates pursuant to the ATSA up to a total of \$1.12 billion of aggregate payments. Any unvested 2019 Warrants will become vested upon a change

## [Table of Contents](#)

of control (as defined in the 2019 Warrant) or certain transfers of 30% or more of the voting power in the Company to a new person or group (other than this offering or any follow-on equity offering by the Company or the Apollo Stockholder pursuant to an effective registration statement so long as no person or group (within the meaning of the Exchange Act) acquires more than 50% of the voting power of the Company in such offering). As is the case for investment in our company generally, the exercise of the 2019 Warrants is limited by restrictions imposed by federal law on foreign ownership and control of U.S. airlines. See “—*Limited Ownership and Voting by Foreign Owners.*”

### **Certain Corporate Anti-takeover Provisions**

Certain provisions in our certificate of incorporation and bylaws summarized below may be deemed to have an anti-takeover effect and may delay, deter or prevent a tender offer or takeover attempt that a stockholder might consider to be in its best interests, including attempts that might result in a premium being paid over the market price for the shares held by stockholders.

#### *Preferred Stock*

Our certificate of incorporation contains provisions that permit our board of directors to issue, without any further vote or action by stockholders, shares of preferred stock in one or more series and, with respect to each such series, to fix the number of shares constituting the series and the designation of the series, the voting rights (if any) of the shares of the series, and the powers, preference and relative, participation, optional and other special rights, if any, and any qualifications, limitations or restrictions, of the shares of such series.

#### *Classified Board of Directors*

Our certificate of incorporation provides that our board of directors will be divided into three classes of directors, with the classes to be as nearly equal in number as possible, and with the directors in each class serving staggered three-year terms. As a result, approximately one-third of our board of directors will be elected each year. The classification of directors will have the effect of making it more difficult for stockholders to change the composition of our board of directors.

#### *Removal of Directors; Vacancies*

Under the DGCL, unless otherwise provided in our certificate of incorporation, directors serving on a classified board may be removed by the stockholders only for cause. Our certificate of incorporation provides that directors may be removed with or without cause upon the affirmative vote of a majority in voting power of all outstanding shares of stock entitled to vote thereon, voting together as a single class; provided, however, that from and after the time Apollo and its affiliates, including the Apollo Stockholder, cease to beneficially own, in the aggregate, at least 50.1% of the voting power of our outstanding common stock, directors may only be removed for cause, and only by the affirmative vote of holders of at least 66 2/3% in voting power of all the then-outstanding shares of stock of the Company entitled to vote thereon, voting together as a single class. Any vacancy on our board of directors in respect of an Apollo Director shall only be filled by the Apollo Stockholder. Any other vacancy on our board of directors will be filled only by the affirmative vote of a majority of the remaining directors, although less than a quorum.

#### *No Cumulative Voting*

Under our certificate of incorporation, stockholders do not have the right to cumulative votes in the election of directors.

#### *Special Meetings of Stockholders*

Our certificate of incorporation provides that if less than 50.1% of the voting power of our outstanding common stock is beneficially owned by Apollo and its affiliates, including the Apollo Stockholder, special

## Table of Contents

meetings of the stockholders may be called only by the chairman of the board of directors or by the secretary at the direction of a majority of the directors then in office. For so long as at least 50.1% of the voting power of our outstanding common stock is beneficially owned by Apollo and its affiliates, including the Apollo Stockholder, special meetings may also be called by the secretary at the written request of the holders of a majority of the voting power of the then outstanding common stock. The business transacted at any special meeting will be limited to the proposal or proposals included in the notice of the meeting.

### *Stockholder Action by Written Consent*

Subject to the rights of the holders of one or more series of our preferred stock then outstanding, any action required or permitted to be taken by stockholders must be effected at a duly called annual or special meeting of our stockholders; provided, that prior to the time at which Apollo and its affiliates, including the Apollo Stockholder, cease to beneficially own at least 50.1% of the voting power our outstanding common stock, any action required or permitted to be taken at any annual or special meeting of our stockholders may be taken without a meeting, without prior notice and without a vote, if a consent or consents in writing, setting forth the action so taken, is signed by or on behalf of the holders of outstanding stock having not less than the minimum number of votes that would be necessary to authorize or take such action at a meeting at which all shares entitled to vote thereon were present and voted and are delivered in accordance with applicable Delaware law.

### *Advance Notice Requirements for Stockholder Proposals and Director Nominations*

Our bylaws provide that stockholders other than Apollo and its affiliates, including the Apollo Stockholder, who are seeking to bring business before an annual meeting of stockholders, or to nominate candidates for election as directors at an annual meeting of stockholders, must provide timely notice thereof in writing. To be timely, a stockholder's notice generally must be delivered to and received at our principal executive offices not less than 90 days nor more than 120 days prior to the first anniversary of the preceding year's annual meeting; provided, that in the event that the date of such meeting is advanced more than 30 days prior to, or delayed by more than 60 days after, the anniversary of the preceding year's annual meeting of our stockholders, a stockholder's notice to be timely must be so delivered not earlier than the close of business on the 120th day prior to such meeting and not later than the close of business on the later of the 90th day prior to such meeting or, if the first public announcement of the date of such meeting is less than 100 days prior to the date of such annual meeting, the 10th day following the day on which public announcement of the date of such meeting is first made. Our bylaws specify certain requirements as to the form and content of a stockholder's notice. These provisions may preclude stockholders from bringing matters before an annual meeting of stockholders or from making nominations for directors at an annual meeting of stockholders.

All the foregoing provisions of our certificate of incorporation and bylaws could discourage potential acquisition proposals and could delay or prevent a change in control. These provisions are intended to enhance the likelihood of continuity and stability in the composition of the board of directors and in the policies formulated by the board of directors and to discourage certain types of transactions that may involve an actual or threatened change in control. These same provisions may delay, deter or prevent a tender offer or takeover attempt that a stockholder might consider to be in its best interest. In addition, such provisions could have the effect of discouraging others from making tender offers for our shares and, as a consequence, they also may inhibit fluctuations in the market price of our common stock that could result from actual or rumored takeover attempts. Such provisions also may have the effect of preventing changes in our management.

### *Delaware Takeover Statute*

Our certificate of incorporation provides that we are not governed by Section 203 of the DGCL which, in the absence of such provisions, would have imposed additional requirements regarding mergers and other business combinations.

## Table of Contents

However, our certificate of incorporation, which will become effective prior to the consummation of this offering, will include a provision that restricts us from engaging in any business combination with an interested stockholder for three years following the date that person becomes an interested stockholder. Such restrictions shall not apply to any business combination between Apollo and any affiliate thereof, including the Apollo Funds and the Apollo Stockholder, or their direct and indirect transferees, on the one hand, and us, on the other.

Additionally, we would be able to enter into a business combination with an interested stockholder if:

- before that person became an interested stockholder, our board of directors approved the transaction in which the interested stockholder became an interested stockholder or approved the business combination;
- upon consummation of the transaction that resulted in the interested stockholder becoming an interested stockholder, the interested stockholder owned at least 85% of our voting stock outstanding at the time the transaction commenced, excluding for purposes of determining the voting stock outstanding (but not the outstanding voting stock owned by the interested stockholder) stock held by directors who are also officers of our Company and by employee stock plans that do not provide employees with the right to determine confidentially whether shares held under the plan will be tendered in a tender or exchange offer; or
- following the transaction in which that person became an interested stockholder, the business combination is approved by our board of directors and authorized at a meeting of stockholders by the affirmative vote of the holders of at least 66 2/3% of the voting power of our outstanding voting stock not owned by the interested stockholder.

In general, a “business combination” is defined to include mergers, asset sales and other transactions resulting in financial benefit to a stockholder and an “interested stockholder” is any person who, together with affiliates and associates, is the owner of 15% or more of our outstanding voting stock or is our affiliate or associate and was the owner of 15% or more of our outstanding voting stock at any time within the three-year period immediately before the date of determination. Under our certificate of incorporation, an “interested stockholder” generally does not include Apollo and any affiliate thereof or their direct and indirect transferees.

This provision of our certificate of incorporation could prohibit or delay mergers or other takeover or change in control attempts and, accordingly, may discourage attempts to acquire us even though such a transaction may offer our stockholders the opportunity to sell their stock at a price above the prevailing market price.

### *Amendment of Our Certificate of Incorporation*

Under Delaware law, our certificate of incorporation may be amended only with the affirmative vote of holders of at least a majority of the outstanding stock entitled to vote thereon.

Notwithstanding the foregoing, our certificate of incorporation provides that, from and after the time Apollo and its affiliates, including the Apollo Stockholder, cease to beneficially own at least 50.1% of the voting power of our outstanding common stock, in addition to any vote required by applicable law, our certificate of incorporation or bylaws, the affirmative vote of holders of at least 66 2/3% of the voting power of our outstanding shares of our capital stock entitled to vote thereon, voting together as a single class, is required to amend the following provisions of our certificate of incorporation:

- the provision authorizing the board of directors to designate one or more series of preferred stock and, by resolution, to provide the rights, powers and preferences, and the qualifications, limitations and restrictions thereof, of any series of preferred stock;
- the provisions providing for a classified board of directors, establishing the term of office of directors, relating to the removal of directors, and specifying the manner in which vacancies on the board of directors and newly created directorships may be filled;

## Table of Contents

- the provisions authorizing our board of directors to make, alter, amend or repeal our bylaws;
- the provisions regarding the calling of special meetings and stockholder action by written consent in lieu of a meeting;
- the provisions eliminating monetary damages for breaches of fiduciary duty by a director;
- the provisions providing for indemnification and advance of expenses of our directors and officers;
- the provisions regarding competition and corporate opportunities;
- the provision specifying that, unless we consent in writing to the selection of an alternative forum, the Chancery Court of the State of Delaware will be the sole and exclusive forum for intra-corporate disputes;
- the provisions regarding entering into business combinations with interested stockholders;
- the provision requiring that, from and after the time Apollo and its affiliates, including the Apollo Stockholder, cease to beneficially own at least 50.1% of the voting power of our outstanding common stock, amendments to specified provisions of our certificate of incorporation require the affirmative vote of 66 2/3% in voting power of our outstanding stock, voting as a single class; and
- the provision requiring that, from and after the time Apollo and its affiliates, including the Apollo Stockholder, cease to beneficially own at least 50.1% of the voting power of our outstanding common stock, amendments by the stockholders to our bylaws require the affirmative vote of 66 2/3% in voting power of our outstanding stock, voting as a single class.

### *Amendment of Our Bylaws*

Our bylaws provide that they can be amended by the vote of the holders of shares constituting a majority of the voting power or by the vote of a majority of the board of directors. However, our certificate of incorporation provides that, from and after the time Apollo and its affiliates, including the Apollo Stockholder, cease to beneficially own at least 50.1% of the voting power of our outstanding common stock, in addition to any vote required under our certificate of incorporation, the affirmative vote of the holders of at least 66 2/3% of the voting power of the outstanding shares of stock entitled to vote thereon, voting as a single class, is required for the stockholders to alter, amend or repeal any provision of our bylaws or to adopt any provision inconsistent therewith.

The provisions of the DGCL, our certificate of incorporation and our bylaws could have the effect of discouraging others from attempting hostile takeovers and, as a consequence, they may also inhibit temporary fluctuations in the market price of our common stock that often result from actual or rumored hostile takeover attempts. These provisions may also have the effect of preventing changes in our management. It is possible that these provisions could make it more difficult to accomplish transactions that stockholders may otherwise deem to be in their best interests.

### **Corporate Opportunity**

Under Delaware law, officers and directors generally have an obligation to present to the corporation they serve business opportunities which the corporation is financially able to undertake and which falls within the corporation's business line and are of practical advantage to the corporation, or in which the corporation has an actual or expectant interest. A corollary of this general rule is that when a business opportunity comes to an officer or director that is not one in which the corporation has an actual or expectant interest, the officer is generally not obligated to present it to the corporation. Certain of our officers and directors may serve as officers, directors or fiduciaries of other entities and, therefore, may have legal obligations relating to presenting available business opportunities to us and to other entities. Potential conflicts of interest may arise when our officers and directors learn of business opportunities (e.g., the opportunity to acquire an asset or portfolio of assets, to make a

## [Table of Contents](#)

specific investment, to effect a sale transaction, etc.) that would be of material advantage to us and to one or more other entities of which they serve as officers, directors or other fiduciaries.

Section 122(17) of the DGCL permits a corporation to renounce, in advance, in its certificate of incorporation or by action of its board of directors, any interest or expectancy of a corporation in certain classes or categories of business opportunities. Where business opportunities are so renounced, certain of our officers and directors will not be obligated to present any such business opportunities to us. Our certificate of incorporation provides that, to the fullest extent permitted by law, no officer or director of ours who is also an officer, director, employee, managing director or other affiliate of Apollo will be liable to us or our stockholders for breach of any fiduciary duty by reason of the fact that any such individual directs a corporate opportunity to Apollo, as applicable, instead of us, or does not communicate information regarding a corporate opportunity to us that the officer, director, employee, managing director or other affiliate has directed to Apollo, as applicable. As of the date of this prospectus, this provision of our certificate of incorporation relates only to the directors nominated by the Apollo Stockholder.

### **Limited Ownership and Voting by Foreign Owners**

To comply with restrictions imposed by federal law on foreign ownership and control of U.S. airlines, our certificate of incorporation and bylaws to be in effect immediately prior to the consummation of this offering restrict ownership and control of shares of our common stock by non-U.S. citizens. The restrictions imposed by federal law currently require that we be owned and controlled by U.S. citizens, that no more than 25.0% of our voting stock be owned or controlled, directly or indirectly, by persons or entities who are not U.S. citizens, as defined in 49 U.S.C. § 40102(a)(15), that no more than 49.0% of our stock be owned or controlled, directly or indirectly, by persons or entities who are not U.S. citizens and are from countries that have entered into “open skies” air transport agreements with the United States, that our president and at least two-thirds of the members of our board of directors and other managing officers be U.S. citizens and that we be under the actual control of U.S. citizens. Our certificate of incorporation and bylaws to be in effect immediately prior to the consummation of this offering provide that the failure of non-U.S. citizens to register their shares on a separate stock record, which we refer to as the “foreign stock record,” would result in a loss of their voting rights in the event and to the extent that the aggregate foreign ownership of the outstanding common stock exceeds the foreign ownership restrictions imposed by federal law. Our bylaws further provide that no shares of our common stock will be registered on the foreign stock record if the amount so registered would exceed the foreign ownership restrictions imposed by federal law. If it is determined that the amount registered in the foreign stock record exceeds the foreign ownership restrictions imposed by federal law, shares will be removed from the foreign stock record, resulting in the loss of voting rights, in reverse chronological order based on the date of registration therein, until the number of shares registered therein does not exceed the foreign ownership restrictions imposed by federal law. We are currently in compliance with these ownership restrictions.

By participating in this offering, you are representing that you are a citizen of the United States, as defined in 49 U.S.C. § 40102(a)(15). For purposes of the restrictions on foreign ownership and control of U.S. airlines, “citizen of the United States” means (A) an individual who is a citizen of the United States; (B) a partnership each of whose partners is an individual who is a citizen of the United States; or (C) a corporation or association organized under the laws of the United States or a State, the District of Columbia, or a territory or possession of the United States, of which the president and at least two-thirds of the board of directors and other managing officers are citizens of the United States, which is under the actual control of citizens of the United States, and in which at least 75% of the voting interest is owned or controlled by persons that are citizens of the United States.

### **Exclusive Forum Selection**

Unless we consent in writing to the selection of an alternative forum, the Chancery Court of the State of Delaware will, to the fullest extent permitted by law, be the sole and exclusive forum for:

- any derivative action or proceeding brought on our behalf;

## Table of Contents

- any action asserting a claim of breach of a fiduciary duty owed by any of our directors, officers, employees or agents to us or our stockholders;
- any action asserting a claim arising pursuant to any provision of the DGCL or of our certificate of incorporation or our bylaws; or
- any action asserting a claim against us or any of our directors or officers governed by the internal affairs doctrine,

in each such case subject to the Delaware Court of Chancery having personal jurisdiction over the indispensable parties named as defendants.

Notwithstanding the foregoing, the exclusive forum provision will not apply to suits brought to enforce any liability or duty created by the Securities Act, the Exchange Act or any other claim for which the federal courts have exclusive jurisdiction. Any person or entity purchasing or otherwise acquiring any interest in shares of our capital stock will be deemed to have notice of and, to the fullest extent permitted by law, to have consented to the foregoing forum selection provisions. However, the enforceability of similar forum provisions in other companies' certificates of incorporation has been challenged in legal proceedings, and it is possible that a court could find these types of provisions to be unenforceable.

### **Limitation of Liability and Indemnification**

Our certificate of incorporation limits the liability of our directors to the maximum extent permitted by the DGCL. The DGCL provides that directors will not be personally liable for monetary damages for breach of their fiduciary duties as directors, except liability:

- for any breach of their duty of loyalty to the corporation or its stockholders;
- for acts or omissions not in good faith or which involve intentional misconduct or a knowing violation of laws;
- under Section 174 of the DGCL (governing distributions to stockholders); or
- for any transaction from which the director derived an improper personal benefit.

However, if the DGCL is amended to authorize corporate action further eliminating or limiting the personal liability of directors, then the liability of our directors will be eliminated or limited to the fullest extent permitted by the DGCL, as so amended. The modification or repeal of this provision of our certificate of incorporation will not adversely affect any right or protection of a director existing at the time of such modification or repeal.

Our certificate of incorporation provides that we will, to the fullest extent from time to time permitted by law, indemnify our directors and officers against all liabilities and expenses in any suit or proceeding, arising out of their status as an officer or director or their activities in these capacities. We will also indemnify any person who, at our request, is or was serving as a director, officer or employee of another corporation, partnership, joint venture, trust or other enterprise. We may, by action of our board of directors, provide indemnification to our employees and agents within the same scope and effect as the foregoing indemnification of directors and officers.

The right to be indemnified will include the right of an officer or a director to be paid expenses in advance of the final disposition of any proceeding, provided that, if required by law, we receive an undertaking to repay such amount if it will be determined that he or she is not entitled to be indemnified.

Our board of directors may take such action as it deems necessary to carry out these indemnification provisions, including adopting procedures for determining and enforcing indemnification rights and purchasing insurance policies. Our board of directors may also adopt bylaws, resolutions or contracts implementing indemnification arrangements as may be permitted by law. Neither the amendment nor the repeal of these

---

## [Table of Contents](#)

indemnification provisions, nor any provision of our certificate of incorporation that is inconsistent with these indemnification provisions, will eliminate or reduce any rights to indemnification relating to their status or any activities prior to such amendment, repeal or adoption.

We believe these provisions will assist in attracting and retaining qualified individuals to serve as directors.

### **Listing**

We intend to apply to list our shares of common stock on the NYSE under the symbol “SNCY.”

### **Transfer Agent and Registrar**

The transfer agent and registrar for our common stock is .



## SHARES ELIGIBLE FOR FUTURE SALE

Prior to this offering, there has been no public market for our common stock. As described below, only a limited number of shares will be available for sale shortly after this offering due to contractual and legal restrictions on resale. Nevertheless, sales of a substantial number of shares of our common stock in the public market after such restrictions lapse, or the perception that those sales may occur, could adversely affect the prevailing market price of our common stock at such time and our ability to raise equity-related capital at a time and price we deem appropriate.

Upon the completion of this offering, we will have outstanding an aggregate of      shares of common stock. Additionally, we will have      options outstanding, which are exercisable into      shares of common stock, and      warrants outstanding, which are exercisable for shares of common stock, subject to their vesting terms and limitations imposed by federal law on foreign ownership and control of U.S. airlines. See “*Description of Capital Stock—Limited Ownership and Voting by Foreign Owners.*” Of these shares, all of the      shares of common stock to be sold in this offering (or shares assuming the underwriters exercise their option to purchase additional shares in full) will be freely tradable without restriction unless the shares are held by any of our “affiliates” as such term is defined in Rule 144 under the Securities Act, and without further registration under the Securities Act. All remaining shares of common stock will be deemed “restricted securities” as such term is defined under Rule 144. The restricted securities were, or will be, issued and sold by us in private transactions and are eligible for public sale only if registered under the Securities Act or if they qualify for an exemption from registration under Rule 144 or Rule 701 under the Securities Act, which rules are summarized below.

As a result of the lock-up agreements described below and the provisions of Rule 144 and Rule 701 under the Securities Act, the shares of our common stock (excluding the shares to be sold in this offering) that will be available for sale in the public market are as follows:

- no shares will be eligible for sale on the date of this prospectus or prior to 180 days after the date of this prospectus; and
- shares will be eligible for sale upon the expiration of the lock-up agreements beginning 180 days after the date of this prospectus and when permitted under Rule 144 or Rule 701 or other applicable securities laws.

### Lock-up Agreements

We, the selling stockholder, all of our other existing stockholders and all of our directors and executive officers have agreed not to sell any common stock or securities convertible into or exercisable or exchangeable for shares of common stock for a period of 180 days from the date of this prospectus, subject to certain exceptions. Please see “*Underwriting*” for a description of these lock-up provisions. Certain underwriters, as described in “*Underwriting*,” in their sole discretion, may at any time release all or any portion of the shares from the restrictions in such agreements, subject to applicable notice requirements.

### Rule 144

In general, under Rule 144 under the Securities Act as currently in effect, a person (or persons whose shares are aggregated) who is not deemed to have been an affiliate of ours at any time during the six months preceding a sale, and who has beneficially owned restricted securities within the meaning of Rule 144 for at least six months (including any period of consecutive ownership of preceding non-affiliated holders) would be entitled to sell those shares, subject only to the availability of current public information about us. A non-affiliated person who has beneficially owned restricted securities within the meaning of Rule 144 for at least one year would be entitled to sell those shares without regard to the provisions of Rule 144.

A person (or persons whose shares are aggregated) who is deemed to be an affiliate of ours and who has beneficially owned restricted securities within the meaning of Rule 144 for at least six months would be entitled

## [Table of Contents](#)

to sell within any three-month period a number of shares that does not exceed the greater of one percent of the then outstanding shares of our common stock or the average weekly trading volume of our common stock reported by the NYSE during the four calendar weeks preceding the filing of notice of the sale. Such sales are also subject to certain manner of sale provisions, notice requirements and the availability of current public information about us.

### **Rule 701**

In general, under Rule 701 under the Securities Act, any of our employees, directors, officers, consultants or advisors who purchases shares from us in connection with a compensatory stock or option plan or other written agreement before the effective date of this offering is entitled to sell such shares 90 days after the effective date of this offering in reliance on Rule 144, without having to comply with the holding period requirement of Rule 144 and, in the case of non-affiliates, without having to comply with the public information, volume limitation or notice filing provisions of Rule 144. The SEC has indicated that Rule 701 will apply to typical stock options granted by an issuer before it becomes subject to the reporting requirements of the Exchange Act, along with the shares acquired upon exercise of such options, including exercises after the date of this prospectus.

### **Warrants**

As of December 31, 2019, and after giving effect to the Reorganization Transactions, we will have warrants to purchase an aggregate of \_\_\_\_\_ shares of our common stock outstanding, the exercise of which is subject to limitations imposed by federal law on foreign ownership and control of U.S. airlines, of which warrants to purchase \_\_\_\_\_ shares will have vested. During the period the warrants are outstanding, we will reserve from our authorized and unissued common stock a sufficient number of shares to provide for the issuance of shares of common stock underlying the warrants upon the exercise of the warrants. See “*Description of Capital Stock—Warrants.*”

### **Stock Options**

As of December 31, 2019, and after giving effect to the Reorganization Transactions, we will have options to purchase an aggregate of \_\_\_\_\_ shares of our common stock outstanding, the exercise of which is subject to limitations imposed by federal law on foreign ownership and control of U.S. airlines, of which options to purchase \_\_\_\_\_ shares will have met the time-based requirements of the applicable vesting schedule. During the period the options are outstanding, we will reserve from our authorized and unissued common stock a sufficient number of shares to provide for the issuance of shares of common stock underlying the options upon the exercise of the options.

### **Stock Issued Under Employee Plans**

We intend to file a registration statement on Form S-8 under the Securities Act to register our common stock issuable under the SCA Acquisition Equity Plan and the Omnibus Incentive Plan. This registration statement on Form S-8 is expected to be filed following the effective date of the registration statement of which this prospectus is a part and will be effective upon filing. Accordingly, shares registered under such registration statement will be available for sale in the open market following the effective date, unless such shares are subject to vesting restrictions with us, Rule 144 restrictions applicable to our affiliates or the lock-up restrictions described above.

### **Registration Rights**

Following this offering and subject to the lock-up agreements, certain of our stockholders will be entitled to certain rights with respect to the registration of the sale of their shares of common stock under the Securities Act. For more information, see “*Certain Relationships and Related Party Transactions—Registration Rights Agreement*” and “*Certain Relationships and Related Party Transactions—Amazon Registration Rights Agreement.*” After such registration, these shares of common stock will become freely tradable without restriction under the Securities Act.

## MATERIAL U.S. FEDERAL INCOME TAX CONSIDERATIONS

The following is a discussion of the material U.S. federal income tax considerations applicable to Non-U.S. Holders (as defined herein) with respect to the ownership and disposition of our common stock issued pursuant to this offering. The following discussion is based upon current provisions of the Code, U.S. judicial decisions, administrative pronouncements and existing and proposed Treasury regulations, all as in effect as of the date hereof. All of the preceding authorities are subject to change at any time, possibly with retroactive effect, so as to result in U.S. federal income tax consequences different from those discussed below. We have not requested, and will not request, a ruling from the U.S. Internal Revenue Service (the “IRS”) with respect to any of the U.S. federal income tax consequences described below, and as a result there can be no assurance that the IRS will not disagree with or challenge any of the conclusions we have reached and describe herein.

This discussion only addresses beneficial owners of our common stock that hold such common stock as a capital asset within the meaning of Section 1221 of the Code (generally, property held for investment). This discussion does not address all aspects of U.S. federal income taxation that may be important to a Non-U.S. Holder in light of such Non-U.S. Holder’s particular circumstances or that may be applicable to Non-U.S. Holders subject to special treatment under U.S. federal income tax law (including, for example, financial institutions, regulated investment companies, real estate investment trusts, dealers in securities, traders in securities that elect mark-to-market treatment, insurance companies, tax-exempt entities, Non-U.S. Holders who acquire our common stock pursuant to the exercise of employee stock options or otherwise as compensation for their services, Non-U.S. Holders liable for the alternative minimum tax, controlled foreign corporations, passive foreign investment companies, former citizens or former long-term residents of the United States, and Non-U.S. Holders that hold our common stock as part of a hedge, straddle, constructive sale or conversion transaction). In addition, this discussion does not address U.S. federal tax laws other than those pertaining to U.S. federal income tax (such as U.S. federal estate or gift tax or the Medicare contribution tax on certain net investment income), nor does it address any aspects of U.S. state, local or non-U.S. taxes. Non-U.S. Holders are urged to consult with their own tax advisors regarding the possible application of these taxes.

For purposes of this discussion, the term “Non-U.S. Holder” means a beneficial owner of our common stock that is an individual, corporation, estate or trust, other than:

- an individual who is a citizen or resident of the United States, as determined for U.S. federal income tax purposes;
- a corporation, or other entity taxable as a corporation for U.S. federal income tax purposes, created or organized in the United States or under the laws of the United States, any state thereof or the District of Columbia;
- an estate, the income of which is includible in gross income for U.S. federal income tax purposes regardless of its source; or
- a trust if: (i) a court within the United States is able to exercise primary supervision over the administration of the trust and one or more U.S. persons have the authority to control all substantial decisions of the trust; or (ii) it has a valid election in effect under applicable U.S. Treasury regulations to be treated as a domestic trust.

If an entity or arrangement treated as a partnership for U.S. federal income tax purposes holds shares of our common stock, the tax treatment of a person treated as a partner of such partnership generally will depend on the status of the partner and the activities of the partnership. Persons that, for U.S. federal income tax purposes, are treated as partners in a partnership holding shares of our common stock are urged to consult their own tax advisors.

Prospective purchasers are urged to consult their tax advisors as to the particular consequences to them under U.S. federal, state and local, and applicable foreign tax laws of the acquisition, ownership and disposition of our common stock.

## Distributions

Distributions of cash or property that we pay in respect of our common stock will constitute dividends for U.S. federal income tax purposes to the extent paid from our current or accumulated earnings and profits (as determined under U.S. federal income tax principles). Subject to the discussions below under “—U.S. Trade or Business Income,” “—Information Reporting and Backup Withholding” and “—FATCA,” you generally will be subject to U.S. federal withholding tax at a 30% rate, or at a reduced rate prescribed by an applicable income tax treaty, on any dividends received in respect of our common stock. If the amount of the distribution exceeds our current and accumulated earnings and profits, such excess first will be treated as a return of capital to the extent of your tax basis in our common stock, and thereafter will be treated as capital gain. However, except to the extent that we elect (or the paying agent or other intermediary through which you hold your common stock elects) otherwise, we (or the intermediary) must generally withhold at the applicable rate on the entire distribution, in which case you would be entitled to a refund from the IRS for the withholding tax on the portion, if any, of the distribution that exceeded our current and accumulated earnings and profits.

In order to obtain a reduced rate of U.S. federal withholding tax under an applicable income tax treaty, you will be required to provide a properly executed IRS Form W-8BEN or Form W-8BEN-E (or, in each case, a successor form) certifying your entitlement to benefits under the treaty. Special certifications and other requirements apply to certain Non-U.S. Holders that are pass-through entities rather than corporations or individuals for U.S. federal income tax purposes. If you are eligible for a reduced rate of U.S. federal withholding tax under an income tax treaty, you may obtain a refund or credit of any excess amounts withheld by filing an appropriate claim for a refund with the IRS. You are urged to consult your own tax advisor regarding your possible entitlement to benefits under an applicable income tax treaty.

## Sale, Exchange or Other Taxable Disposition of Common Stock

Subject to the discussions below under “—U.S. Trade or Business Income,” “—Information Reporting and Backup Withholding” and “—FATCA,” you generally will not be subject to U.S. federal income or withholding tax in respect of any gain on a sale, exchange or other taxable disposition of our common stock unless:

- the gain is U.S. trade or business income, in which case, such gain will be taxed as described in “—U.S. Trade or Business Income” below;
- you are an individual who is present in the United States for 183 or more days in the taxable year of the disposition and certain other conditions are met, in which case you will be subject to U.S. federal income tax at a rate of 30% (or a reduced rate under an applicable income tax treaty) on the amount by which certain capital gains allocable to U.S. sources exceed certain capital losses allocable to U.S. sources; or
- we are or have been a “United States real property holding corporation” (a “USRPHC”) under Section 897 of the Code at any time during the shorter of the five-year period ending on the date of the disposition and your holding period for the common stock, in which case, subject to the exception set forth in the second sentence of the next paragraph, such gain will be subject to U.S. federal income tax as described in “—U.S. Trade or Business Income” below.

In general, a corporation is a USRPHC if the fair market value of its “United States real property interests” equals or exceeds 50% of the sum of the fair market value of its worldwide real property interests and its other assets used or held for use in a trade or business. In the event that we are determined to be a USRPHC, gain will, nonetheless, not be subject to tax as U.S. trade or business income if your holdings (direct and indirect, taking into account certain constructive ownership rules) at all times during the applicable period described in the third bullet point above constituted 5% or less of our common stock, provided that our common stock was regularly traded on an established securities market during such period. We believe that we are not currently, and we do not anticipate becoming in the future, a “United States real property holding corporation” for U.S. federal income tax purposes.

## **U.S. Trade or Business Income**

For purposes of this discussion, dividend income and gain on the sale, exchange or other taxable disposition of our common stock will be considered to be “U.S. trade or business income” if (A)(i) such income or gain is effectively connected with your conduct of a trade or business within the United States and (ii) if you are eligible for the benefits of an income tax treaty with the United States and such treaty requires, such gain is attributable to a permanent establishment (or, if you are an individual, a fixed base) that you maintain in the United States or (B) with respect to gain, we are or have been a USRPHC at any time during the shorter of the five-year period ending on the date of the disposition of our common stock and your holding period for our common stock (subject to the exception set forth above in the second paragraph of “—*Sale, Exchange or Other Taxable Disposition of Common Stock*”). Generally, U.S. trade or business income is not subject to U.S. federal withholding tax (provided that you comply with applicable certification and disclosure requirements, including providing a properly executed IRS Form W-8ECI (or successor form)); instead, you are subject to U.S. federal income tax on a net basis at regular U.S. federal income tax rates (generally in the same manner as a U.S. person) on your U.S. trade or business income. If you are a corporation, any U.S. trade or business income that you receive may also be subject to a “branch profits tax” at a 30% rate, or at a lower rate prescribed by an applicable income tax treaty.

## **Information Reporting and Backup Withholding**

We must annually report to the IRS and to each Non-U.S. Holder any dividend income that is subject to U.S. federal withholding tax or that is exempt from such withholding pursuant to an income tax treaty. Copies of these information returns may also be made available under the provisions of a specific treaty or agreement to the tax authorities of the country in which a Non-U.S. Holder resides. Under certain circumstances, the Code imposes a backup withholding obligation on certain reportable payments. Dividends paid to you will generally be exempt from backup withholding if you provide a properly executed IRS Form W-8BEN or Form W-8BEN-E (or, in each case, a successor form) or otherwise establish an exemption and the applicable withholding agent does not have actual knowledge or reason to know that you are a U.S. person or that the conditions of such other exemption are not, in fact, satisfied.

The payment of the proceeds from the disposition of our common stock to or through the U.S. office of any broker (U.S. or non-U.S.) will be subject to information reporting and possible backup withholding unless you certify as to your non-U.S. status under penalties of perjury or otherwise establish an exemption and the broker does not have actual knowledge or reason to know that you are a U.S. person or that the conditions of any other exemption are not, in fact, satisfied. The payment of proceeds from the disposition of our common stock to or through a non-U.S. office of a non-U.S. broker will not be subject to information reporting or backup withholding unless the non-U.S. broker has certain types of relationships with the United States (a “U.S. related financial intermediary”). In the case of the payment of proceeds from the disposition of our common stock to or through a non-U.S. office of a broker that is either a U.S. person or a U.S. related financial intermediary, the Treasury regulations require information reporting (but not backup withholding) on the payment unless the broker has documentary evidence in its files that the owner is not a U.S. person and the broker has no knowledge to the contrary. You are urged to consult your tax advisor on the application of information reporting and backup withholding in light of your particular circumstances.

Backup withholding is not an additional tax. Any amounts withheld under the backup withholding rules from a payment to you will be refunded or credited against your U.S. federal income tax liability, if any, provided that the required information is timely furnished to the IRS.

## **FATCA**

Pursuant to Section 1471 through 1474 of the Code, commonly referred to as the Foreign Account Tax Compliance Act (“FATCA”), foreign financial institutions (which include most foreign hedge funds, private

## [Table of Contents](#)

equity funds, mutual funds, securitization vehicles and any other investment vehicles) and certain other foreign entities that do not otherwise qualify for an exemption must comply with information reporting rules with respect to their U.S. account holders and investors or be subject to a withholding tax on U.S. source payments made to them (whether received as a beneficial owner or as an intermediary for another party).

More specifically, a foreign financial institution or other foreign entity that does not comply with the FATCA reporting requirements or otherwise qualify for an exemption will generally be subject to a 30% withholding tax with respect to any “withholdable payments.” For this purpose, withholdable payments generally include U.S.-source payments otherwise subject to nonresident withholding tax (e.g., U.S.-source dividends). The FATCA withholding tax will apply even if the payment would otherwise not be subject to U.S. nonresident withholding tax (e.g., because it is capital gain). Foreign financial institutions located in jurisdictions that have an intergovernmental agreement with the United States governing FATCA may be subject to different rules.

FATCA currently applies to dividends made in respect of our common stock. Proposed Treasury regulations, the preamble to which state that they can be relied upon until final regulations are issued, exempt from FATCA proceeds on dispositions of stock. To avoid withholding on dividends, Non-U.S. Holders may be required to provide the Company (or its withholding agents) with applicable tax forms or other information. Non-U.S. Holders are urged to consult with their own tax advisors regarding the effect, if any, of the FATCA provisions to them based on their particular circumstances.

## UNDERWRITING

Under the terms and subject to the conditions in an underwriting agreement dated the date of this prospectus, the underwriters named below, for whom \_\_\_\_\_ are acting as representatives, have severally agreed to purchase, and we and the selling stockholder have agreed to sell to them, severally, the number of shares indicated below:

<u>Name</u>	<u>Number of Shares</u>
Barclays Capital Inc.	
Total:	<hr/> <hr/> <hr/>

The underwriters and the representatives are collectively referred to as the “underwriters” and the “representatives,” respectively. The underwriters are offering the shares of common stock subject to their acceptance of the shares from us and the selling stockholder and subject to prior sale. The underwriting agreement provides that the obligations of the several underwriters to pay for and accept delivery of the shares of common stock offered by this prospectus are subject to the approval of certain legal matters by their counsel and to certain other conditions. The underwriters are obligated to take and pay for all of the shares of common stock offered by this prospectus if any such shares are taken. However, the underwriters are not required to take or pay for the shares covered by the underwriters’ over-allotment option described below.

The underwriters initially propose to offer part of the shares of common stock directly to the public at the offering price listed on the cover page of this prospectus and part to certain dealers at the public offering price less a concession not to exceed \$ \_\_\_\_\_ per share. After the initial offering of the shares of common stock, the offering price and other selling terms may from time to time be varied by the representatives. The offering of the shares by the underwriters is subject to receipt and acceptance and subject to the underwriters’ right to reject any order in whole or in part.

The selling stockholder has granted to the underwriters an option, exercisable for 30 days from the date of this prospectus, to purchase up to additional shares of common stock from the selling stockholder at the public offering price listed on the cover page of this prospectus, less underwriting discounts and commissions. The underwriters may exercise this option solely for the purpose of covering over-allotments, if any, made in connection with the offering of the shares of common stock offered by this prospectus. To the extent the option is exercised, each underwriter will become obligated, subject to certain conditions, to purchase about the same percentage of the additional shares of common stock as the number listed next to the underwriter’s name in the preceding table bears to the total number of shares of common stock listed next to the names of all underwriters in the preceding table.

We, the selling stockholder and the underwriters have agreed to indemnify each other against certain liabilities, including liabilities under the Securities Act.

The underwriters have informed us that they do not intend sales to discretionary accounts to exceed 5% of the total number of shares of our common stock offered by them.

## Table of Contents

### Commissions and Discounts

The following table shows the per share and total public offering price, underwriting discounts and commissions, and proceeds before expenses to us and the selling stockholder. These amounts are shown assuming both no exercise and full exercise of the underwriters' option to purchase up to an additional      shares of common stock from the selling stockholder.

	Per Share	Total	
		No Exercise	Full Exercise
Public offering price	\$	\$	\$
Underwriting discounts and commissions to be paid by:			
Us	\$	\$	\$
Selling stockholder	\$	\$	\$
Proceeds, before expenses, to us	\$	\$	\$
Proceeds, before expenses, to selling stockholder	\$	\$	\$

The estimated offering expenses payable by us, exclusive of the underwriting discounts and commissions, are approximately \$      . We have agreed to reimburse the underwriters for expense relating to clearance of this offering with the Financial Industry Regulatory Authority, Inc. ("FINRA") up to \$      .

### Listing

We intend to apply to list our common stock on the NYSE under the trading symbol "SNCY."

### Lock-Up Agreements

We, the selling stockholder, all of our directors and officers and the holders of all of our outstanding stock have agreed that, without the prior written consent of      on behalf of the underwriters, we and they will not, during the period ending 180 days after the date of this prospectus (the "restricted period"):

- offer, pledge, sell, contract to sell, sell any option or contract to purchase, purchase any option or contract to sell, grant any option, right or warrant to purchase, lend or otherwise transfer or dispose of, directly or indirectly, any shares of common stock or any securities convertible into or exercisable or exchangeable for shares of common stock;
- file any registration statement with the SEC relating to the offering of any shares of common stock or any securities convertible into or exercisable or exchangeable for common stock; or
- enter into any swap or other arrangement that transfers to another, in whole or in part, any of the economic consequences of ownership of our common stock,

or publicly disclose the intention to do any of the foregoing, whether any such transaction described above is to be settled by delivery of common stock or such other securities, in cash or otherwise. In addition, we and each such person agrees that, without the prior written consent of      on behalf of the underwriters, we or such other person will not, during the restricted period, make any demand for, or exercise any right with respect to, the registration of any shares of our common stock or any security convertible into or exercisable or exchangeable for our common stock.

The lock-up agreements are subject to specified exceptions.

    , in its sole discretion, may release our common stock and other securities subject to the lock-up agreements described above in whole or in part at any time, subject to applicable notice requirements.



### **Price Stabilization, Short Positions and Penalty Bids**

In order to facilitate the offering of our common stock, the underwriters may engage in transactions that stabilize, maintain or otherwise affect the price of our common stock. Specifically, the underwriters may sell more shares than they are obligated to purchase under the underwriting agreement, creating a short position. A short sale is covered if the short position is no greater than the number of shares available for purchase by the underwriters under the over-allotment option. The underwriters can close out a covered short sale by exercising the over-allotment option or purchasing shares in the open market. In determining the source of shares to close out a covered short sale, the underwriters will consider, among other things, the open market price of shares compared to the price available under the over-allotment option. The underwriters may also sell shares in excess of the over-allotment option, creating a naked short position. The underwriters must close out any naked short position by purchasing shares in the open market. A naked short position is more likely to be created if the underwriters are concerned that there may be downward pressure on the price of our common stock in the open market after pricing that could adversely affect investors who purchase in this offering. As an additional means of facilitating this offering, the underwriters may bid for, and purchase, shares of our common stock in the open market to stabilize the price of our common stock. These activities may raise or maintain the market price of our common stock above independent market levels or prevent or retard a decline in the market price of our common stock. The underwriters are not required to engage in these activities and may end any of these activities at any time.

### **Electronic Distribution**

A prospectus in electronic format may be made available on websites maintained by one or more underwriters, or selling group members, if any, participating in this offering. The representatives may agree to allocate a number of shares of common stock to underwriters for sale to their online brokerage account holders. Internet distributions will be allocated by the representatives to underwriters that may make Internet distributions on the same basis as other allocations.

### **Other Relationships**

The underwriters and their respective affiliates are full service financial institutions engaged in various activities, which may include securities trading, commercial and investment banking, financial advisory, investment management, investment research, principal investment, hedging, financing and brokerage activities. Certain of the underwriters and their respective affiliates have, from time to time, performed, and may in the future perform, various financial advisory and investment banking services for us and Apollo, for which they received or will receive customary fees and expenses. Barclays Bank PLC, the administrative agent, collateral agent, lead arranger, bookrunner and syndication agent under our ABL Facility, is an affiliate of Barclays Capital Inc., one of the underwriters in this offering.

In addition, in the ordinary course of their various business activities, the underwriters and their respective affiliates may make or hold a broad array of investments and actively trade debt and equity securities (or related derivative securities) and financial instruments (including bank loans) for their own account and for the accounts of their customers and may at any time hold long and short positions in such securities and instruments. Such investment and securities activities may involve our securities and instruments. The underwriters and their respective affiliates may also make investment recommendations or publish or express independent research views in respect of such securities or instruments and may at any time hold, or recommend to clients that they acquire, long or short positions in such securities and instruments.

### **Pricing of the Offering**

Prior to this offering, there has been no public market for our common stock. The initial public offering price was determined by negotiations between us, the selling stockholder and the representatives. Among the factors considered in determining the initial public offering price were our future prospects and those of our industry in general, our sales, earnings and certain other financial and operating information in recent periods, and the price-earnings ratios, price-sales ratios, market prices of securities, and certain financial and operating information of companies engaged in activities similar to ours.

## **Selling Restrictions**

Other than in the United States, no action has been taken by us or the underwriters that would permit a public offering of the securities offered by this prospectus in any jurisdiction where action for that purpose is required. The securities offered by this prospectus may not be offered or sold, directly or indirectly, nor may this prospectus or any other offering material or advertisements in connection with the offer and sale of any such securities be distributed or published, in any jurisdiction, except under circumstances that will result in compliance with the applicable rules and regulations of that jurisdiction. Persons into whose possession this prospectus comes are advised to inform themselves about and to observe any restrictions relating to the offering and the distribution of this prospectus. This prospectus does not constitute an offer to sell or a solicitation of an offer to buy any securities offered by this prospectus in any jurisdiction in which such an offer or a solicitation is unlawful.

### ***European Economic Area***

In relation to each Member State of the European Economic Area (each, a “Member State”), no offer of shares may be made to the public in that Member State other than:

- (a) to any legal entity which is a qualified investor as defined in the Prospectus Regulation;
- (b) to fewer than 150 natural or legal persons (other than qualified investors as defined in the Prospectus Regulation), subject to obtaining the prior consent of the representatives; or
- (c) in any other circumstances falling within Article 1(4) of the Prospectus Regulation, provided that no such offer of shares shall require us or any of our representatives to publish a prospectus pursuant to Article 3 of the Prospectus Regulation or supplement a prospectus pursuant to Article 23 of the Prospectus Regulation.

Each person in a Member State who initially acquires any shares or to whom any offer is made will be deemed to have represented, acknowledged and agreed to and with each of the representatives and us that it is a “qualified investor” as defined in the Prospectus Regulation.

In the case of any shares being offered to a financial intermediary as that term is used in Article 5 of the Prospectus Regulation, each such financial intermediary will be deemed to have represented, acknowledged and agreed that the shares acquired by it in the offer have not been acquired on a nondiscretionary basis on behalf of, nor have they been acquired with a view to their offer or resale to, persons in circumstances which may give rise to an offer of any shares to the public other than their offer or resale in a Member State to qualified investors as so defined or in circumstances in which the prior consent of the representatives has been obtained to each such proposed offer or resale.

For the purposes of this provision, the expression an “offer of shares to the public” in relation to any shares in any Member State means the communication in any form and by means of sufficient information on the terms of the offer and the shares to be offered so as to enable an investor to decide to purchase shares, and the expression “Prospectus Regulation” means Regulation (EU) 2017/1129.

### ***United Kingdom***

Each underwriter has represented and agreed that:

- (a) it has only communicated or caused to be communicated and will only communicate or cause to be communicated an invitation or inducement to engage in investment activity (within the meaning of Section 21 of the Financial Services and Markets Act 2000 (“FSMA”)) received by it in connection with the issue or sale of the shares of our common stock in circumstances in which Section 21(1) of the FSMA does not apply to us; and

## Table of Contents

- (b) it has complied and will comply with all applicable provisions of the FSMA with respect to anything done by it in relation to the shares of our common stock in, from or otherwise involving the United Kingdom.

### **Canada**

The shares of common stock may be sold only to purchasers purchasing, or deemed to be purchasing, as principal that are accredited investors, as defined in National Instrument 45-106 *Prospectus Exemptions* or subsection 73.3(1) of the *Securities Act* (Ontario), and are permitted clients, as defined in National Instrument 31-103 *Registration Requirements, Exemptions and Ongoing Registrant Obligations*. Any resale of the shares of common stock must be made in accordance with an exemption from, or in a transaction not subject to, the prospectus requirements of applicable securities laws.

Securities legislation in certain provinces or territories of Canada may provide a purchaser with remedies for rescission or damages if this prospectus (including any amendment thereto) contains a misrepresentation, provided that the remedies for rescission or damages are exercised by the purchaser within the time limit prescribed by the securities legislation of the purchaser's province or territory. The purchaser should refer to any applicable provisions of the securities legislation of the purchaser's province or territory for particulars of these rights or consult with a legal advisor.

Pursuant to section 3A.3 of National Instrument 33-105 *Underwriting Conflicts* (NI 33-105), the underwriters are not required to comply with the disclosure requirements of NI 33-105 regarding underwriter conflicts of interest in connection with this offering.

### **Hong Kong**

Shares of our common stock may not be offered or sold by means of any document other than (i) in circumstances which do not constitute an offer to the public within the meaning of the Companies Ordinance (Cap. 32, Laws of Hong Kong), (ii) to "professional investors" within the meaning of the Securities and Futures Ordinance (Cap. 571, Laws of Hong Kong) and any rules made thereunder, or (iii) in other circumstances which do not result in the document being a "prospectus" within the meaning of the Companies Ordinance (Cap. 32, Laws of Hong Kong), and no advertisement, invitation, or document relating to shares of our common stock may be issued or may be in the possession of any person for the purpose of issue (in each case whether in Hong Kong or elsewhere), which is directed at, or the contents of which are likely to be accessed or read by, the public in Hong Kong (except if permitted to do so under the laws of Hong Kong) other than with respect to shares of our common stock which are or are intended to be disposed of only to persons outside Hong Kong or only to "professional investors" within the meaning of the Securities and Futures Ordinance (Cap. 571, Laws of Hong Kong) and any rules made thereunder.

### **Singapore**

This prospectus has not been registered as a prospectus with the Monetary Authority of Singapore. Accordingly, this prospectus and any other document or material in connection with the offer or sale, or invitation for subscription or purchase, of shares of our common stock may not be circulated or distributed, nor may the shares of our common stock be offered or sold, or be made the subject of an invitation for subscription or purchase, whether directly or indirectly, to persons in Singapore other than (i) to an institutional investor pursuant to Section 274 of the Securities and Futures Act, Chapter 289 of Singapore (the "SFA"), (ii) to a relevant person, or any person pursuant to Section 275(1A) of the SFA, and in accordance with the conditions specified in Section 275 of the SFA, or (iii) otherwise pursuant to, and in accordance with the conditions of, any other applicable provision of the SFA.

## Table of Contents

Where shares of our common stock are subscribed or purchased under Section 275 by a relevant person which is:

- (a) a corporation (which is not an accredited investor) the sole business of which is to hold investments and the entire share capital of which is owned by one or more individuals, each of whom is an accredited investor; or
- (b) a trust (where the trustee is not an accredited investor) whose sole purpose is to hold investments and each beneficiary is an accredited investor,

securities or securities-based derivatives contracts (each as defined in Section 2(1) of the SFA) of that corporation or the beneficiaries' rights and interest in that trust shall not be transferable within six months after that corporation or that trust has acquired shares of our common stock under Section 275 of the SFA except:

- (1) to an institutional investor or to a relevant person, or to any person pursuant to Section 275(1A), and in accordance with the conditions, specified in Section 275 of the SFA;
- (2) where no consideration is given for the transfer; or
- (3) where the transfer is by operation of law.

Solely for purposes of the notification requirements under Section 309B(1)(c) of the SFA, we have determined, and hereby notify all relevant persons, that the shares are "prescribed capital markets products" (as defined in the Securities and Futures (Capital Markets Products) Regulations 2018) and Excluded Investment Products (as defined in MAS Notice SFA 04-N12: Notice on the Sale of Investment Products and MAS Notice FAA-N16: Notice on Recommendations on Investment Products).

### ***Japan***

No registration pursuant to Article 4, paragraph 1 of the Financial Instruments and Exchange Law of Japan (Law No. 25 of 1948, as amended) (the "FIEL") has been made or will be made with respect to the solicitation of the application for the acquisition of the shares of common stock.

Accordingly, the shares of common stock have not been, directly or indirectly, offered or sold and will not be, directly or indirectly, offered or sold in Japan or to, or for the benefit of, any resident of Japan (which term as used herein means any person resident in Japan, including any corporation or other entity organized under the laws of Japan) or to others for re-offering or re-sale, directly or indirectly, in Japan or to, or for the benefit of, any resident of Japan except pursuant to an exemption from the registration requirements, and otherwise in compliance with, the FIEL and the other applicable laws and regulations of Japan.

### ***For Qualified Institutional Investors ("QII")***

Please note that the solicitation for newly-issued or secondary securities (each as described in Paragraph 2, Article 4 of the FIEL) in relation to the shares of common stock constitutes either a "QII only private placement" or a "QII only secondary distribution" (each as described in Paragraph 1, Article 23-13 of the FIEL). Disclosure regarding any such solicitation, as is otherwise prescribed in Paragraph 1, Article 4 of the FIEL, has not been made in relation to the shares of common stock. The shares of common stock may only be transferred to QIIs.

### ***For Non-QII Investors***

Please note that the solicitation for newly-issued or secondary securities (each as described in Paragraph 2, Article 4 of the FIEL) in relation to the shares of common stock constitutes either a "small number private placement" or a "small number private secondary distribution" (each as is described in Paragraph 4, Article 23-13 of the FIEL). Disclosure regarding any such solicitation, as is otherwise prescribed in Paragraph 1, Article 4 of the FIEL, has not been made in relation to the shares of common stock. The shares of common stock may only be transferred en bloc without subdivision to a single investor.

## LEGAL MATTERS

The validity of the shares of common stock offered hereby will be passed upon for us by Paul, Weiss, Rifkind, Wharton & Garrison LLP, New York, New York. The validity of the shares of common stock offered hereby will be passed upon for the underwriters by Davis Polk & Wardwell LLP, New York, New York.

## EXPERTS

The consolidated financial statements of SCA Acquisition Holdings, LLC as of December 31, 2018 and for the periods from January 1, 2018 to April 10, 2018 and April 11, 2018 to December 31, 2018 have been included herein in reliance upon the report of KPMG LLP, independent registered public accounting firm, appearing elsewhere herein, and upon the authority of said firm as experts in accounting and auditing.

## WHERE YOU CAN FIND MORE INFORMATION

We have filed with the SEC a registration statement on Form S-1 with respect to the common stock being sold in this offering. This prospectus constitutes a part of that registration statement. This prospectus does not contain all the information set forth in the registration statement and the exhibits and schedules to the registration statement, because some parts have been omitted in accordance with the rules and regulations of the SEC. For further information with respect to us and our common stock being sold in this offering, you should refer to the registration statement and the exhibits and schedules filed as part of the registration statement. Statements contained in this prospectus regarding the contents of any agreement, contract or other document referred to herein are not necessarily complete; reference is made in each instance to the copy of the contract or document filed as an exhibit to the registration statement. Each statement is qualified by reference to the exhibit.

The SEC maintains an Internet site that contains reports, proxy and information statements and other information regarding registrants that file electronically with the SEC. The SEC's website address is [www.sec.gov](http://www.sec.gov).

After we have completed this offering, we will file annual, quarterly and current reports, proxy statements and other information with the SEC. We intend to make these filings available on our website ([www.suncountry.com](http://www.suncountry.com)) once this offering is completed. You can also request copies of these documents, for a copying fee, by writing to the SEC, or you can review these documents on the SEC's website, as described above. In addition, we will provide electronic or paper copies of our filings free of charge upon request.

**INDEX TO CONSOLIDATED FINANCIAL STATEMENTS**

<a href="#">Report of Independent Registered Public Accounting Firm</a>	F-2
Audited Consolidated Financial Statements	
<a href="#">Consolidated Balance Sheet as of December 31, 2018</a>	F-3
<a href="#">Consolidated Statements of Operations for the periods from January 1, 2018 to April 10, 2018 and April 11, 2018 to December 31, 2018</a>	F-5
<a href="#">Consolidated Statements of Changes in Members' Interest for the periods from January 1, 2018 to April 10, 2018 and April 11, 2018 to December 31, 2018</a>	F-6
<a href="#">Consolidated Statements of Cash Flows for the periods from January 1, 2018 to April 10, 2018 and April 11, 2018 to December 31, 2018</a>	F-7
<a href="#">Notes to Consolidated Financial Statements</a>	F-9
Unaudited Consolidated Financial Statements	
<a href="#">Condensed Consolidated Balance Sheets as of September 30, 2019 and December 31, 2018</a>	F-30
<a href="#">Condensed Consolidated Statements of Operations for the nine months ended September 30, 2019 and for the periods from January 1, 2018 to April 10, 2018 and April 11, 2018 to September 30, 2018</a>	F-32
<a href="#">Condensed Consolidated Statements of Changes in Stockholders' Equity for the nine months ended September 30, 2019 and for the periods from January 1, 2018 to April 10, 2018 and April 11, 2018 to September 30, 2018</a>	F-33
<a href="#">Condensed Consolidated Statements of Cash Flows for the nine months ended September 30, 2019 and for the periods from January 1, 2018 to April 10, 2018 and April 11, 2018 to September 30, 2018</a>	F-34
<a href="#">Notes to Condensed Consolidated Financial Statements</a>	F-36

**Report of Independent Registered Public Accounting Firm**

The Board of Directors  
SCA Acquisition Holdings, LLC:

*Opinion on the Consolidated Financial Statements*

We have audited the accompanying consolidated balance sheet of SCA Acquisition Holdings, LLC and subsidiaries (the Company) as of December 31, 2018, the related consolidated statements of operations, changes in members' interest, and cash flows for the periods from January 1, 2018 to April 10, 2018 and April 11, 2018 to December 31, 2018, and the related notes (collectively, the consolidated financial statements). In our opinion, the consolidated financial statements present fairly, in all material respects, the financial position of the Company as of December 31, 2018 and the results of their operations and their cash flows for the periods from January 1, 2018 to April 10, 2018 and April 11, 2018 to December 31, 2018, in conformity with U.S. generally accepted accounting principles.

*Basis for Opinion*

The consolidated financial statements are the responsibility of the Company's management. Our responsibility is to express an opinion on the consolidated financial statements based on our audit. We are a public accounting firm registered with the Public Company Accounting Oversight Board (United States) (PCAOB) and are required to be independent with respect to the Company in accordance with the U.S. federal securities laws and the applicable rules and regulations of the Securities and Exchange Commission and the PCAOB.

We conducted our audit in accordance with the standards of the PCAOB and in accordance with auditing standards generally accepted in the United States of America. Those standards require that we plan and perform the audit to obtain reasonable assurance about whether the consolidated financial statements are free of material misstatement, whether due to error or fraud. Our audit included performing procedures to assess the risks of material misstatement of the consolidated financial statements, whether due to error or fraud, and performing procedures that respond to those risks. Such procedures included examining, on a test basis, evidence regarding the amounts and disclosures in the consolidated financial statements. Our audit also included evaluating the accounting principles used and significant estimates made by management, as well as evaluating the overall presentation of the consolidated financial statements. We believe that our audit provides a reasonable basis for our opinion.

/s/ KPMG LLP

We have served as the Company's auditor since 2018.

Minneapolis, MN  
November 8, 2019

[Table of Contents](#)

## SCA ACQUISITION HOLDINGS, LLC

## CONSOLIDATED BALANCE SHEET

(Dollars in thousands)

	<u>Successor</u> <u>December 31, 2018</u>
<b>ASSETS</b>	
<b>Current Assets:</b>	
Cash and Equivalents	\$ 29,600
Restricted Cash	13,841
Investments	5,947
Accounts Receivable, net	11,064
Short-term Lessor Maintenance Deposits	2,873
Inventory, net	4,830
Prepaid Expenses	12,796
Other Current Assets	467
Total Current Assets	<u>81,418</u>
<b>Property and Equipment:</b>	
Aircraft and Flight Equipment	83,990
Ground Equipment	6,354
Computer Hardware and Software	5,691
Capital Lease Assets	96,696
Rotable Parts	8,760
Total Property & Equipment	201,491
Accumulated Depreciation and Amortization	<u>(10,835)</u>
Property and Equipment, net (note 5)	190,656
<b>Other Assets:</b>	
Goodwill (note 6)	222,223
Intangible Assets, net (note 6)	101,110
Aircraft Lease Deposits (note 13)	17,790
Long-term Lessor Maintenance Deposits	11,085
Deferred Tax Asset (note 11)	49,487
Other Assets	2,063
Total Other Assets	<u>403,758</u>
Total Assets	<u>\$ 675,832</u>

See accompanying Notes to Consolidated Financial Statements



[Table of Contents](#)

## SCA ACQUISITION HOLDINGS, LLC

## CONSOLIDATED BALANCE SHEET

(Dollars in thousands)

	<u>Successor</u> <u>December 31, 2018</u>
<b>LIABILITIES AND MEMBERS' INTEREST</b>	
<b>Current Liabilities:</b>	
Accounts Payable	\$ 28,669
Accrued Salaries, Wages, and Benefits	14,148
Accrued Transportation Taxes	10,370
Air Traffic Liabilities	105,705
Derivative Liabilities (note 9)	12,006
Over-market Liabilities	21,449
Capital Lease Obligations (note 13)	6,115
Loyalty Program Liabilities	13,166
Current Maturities of Long-term Debt (note 7)	8,606
Other Current Liabilities	2,690
Total Current Liabilities	<u>222,924</u>
<b>Long-term Liabilities:</b>	
Over-market Liabilities	68,138
Capital Lease Obligations (note 13)	85,702
Loyalty Program Liabilities	10,784
Long-term Debt (note 7)	49,823
Other Long-term Liabilities	2,814
Total Long-term Liabilities	<u>217,261</u>
Total Liabilities	440,185
<b>Members' Interest:</b>	
Capital Contribution	239,141
Loans to Members	(3,500)
Additional Paid In Capital	373
Retained Earnings	(367)
Total Members' Interest	<u>235,647</u>
Total Liabilities and Members' Interest	<u>\$ 675,832</u>

See accompanying Notes to Consolidated Financial Statements

[Table of Contents](#)

SCA ACQUISITION HOLDINGS, LLC  
CONSOLIDATED STATEMENTS OF OPERATIONS  
(Dollars in thousands, except per share amounts)

	Successor For the period April 11, 2018 to December 31, 2018	Predecessor For the period January 1, 2018 to April 10, 2018
<b>Operating Revenues:</b>		
Passenger	\$ 335,824	\$ 172,897
Other	49,107	24,555
Total Operating Revenue	<u>384,931</u>	<u>197,452</u>
<b>Operating Expenses:</b>		
Aircraft Fuel	119,553	45,790
Salaries, Wages, and Benefits	90,263	36,964
Aircraft Rent	36,831	28,329
Maintenance	15,491	9,508
Sales and Marketing	17,180	10,854
Depreciation and Amortization	14,405	2,526
Ground Handling	23,828	8,619
Landing Fees and Airport Rent	25,977	10,481
Special Items, net	(6,706)	271
Other Operating, net	40,877	17,994
Total Operating Expenses	<u>377,699</u>	<u>171,336</u>
Operating Income	<u>7,232</u>	<u>26,116</u>
<b>Non-operating Income (Expense):</b>		
Interest Income	258	96
Interest Expense	(6,060)	(339)
Other, net	(1,636)	37
Total Non-operating Expense	<u>(7,438)</u>	<u>(206)</u>
Income / (Loss) before Income Tax	<u>(206)</u>	<u>25,910</u>
Income Tax Expense	161	—
Net Income / (Loss)	<u>\$ (367)</u>	<u>\$ 25,910</u>
Net Income / (Loss) per share to common stockholders / units to Member:		
Basic	<u>\$ (0.15)</u>	<u>\$ 0.26</u>
Diluted	<u>\$ (0.15)</u>	<u>\$ 0.26</u>
Shares / Units used for computation:		
Basic	2,472	100,000
Diluted	2,472	100,000
Pro Forma Income Tax Expense		\$ 6,036
Pro Forma Net Income		\$ 19,874
Pro Forma Net Income per unit to Member:		
Basic and diluted		\$ 0.20
Pro Forma units used for computation:		
Basic and diluted		100,000

See accompanying Notes to Consolidated Financial Statements

[Table of Contents](#)

## SCA ACQUISITION HOLDINGS, LLC

CONSOLIDATED STATEMENTS OF CHANGES IN MEMBERS' INTEREST  
(Dollars in thousands)**Predecessor**

	<u>Units</u>	<u>Total</u>
January 1, 2018	100,000,000	\$ 34,422
Net Income / (Loss)	—	25,910
Distributions to Member	—	(10,549)
April 10, 2018	100,000,000	\$ 49,783

**Successor**

	<u>Warrants</u>	<u>Shares</u>	<u>Capital Contribution</u>	<u>Loans to Members</u>	<u>APIC</u>	<u>Retained Earnings</u>	<u>Total</u>
Capital at Purchase on April 11, 2018 - Warrants	2,117,991	—	\$ 165,711	\$ —	\$—	\$ —	\$165,711
Capital at Purchase on April 11, 2018 - Shares	—	282,009	22,064	—	—	—	22,064
Additional Capital Contribution	—	—	43,865	—	—	—	43,865
Member Capital Contribution	—	75,000	7,500	(3,500)	—	—	4,000
Net Income / (Loss)	—	—	—	—	—	(367)	(367)
Equity-based Compensation	—	—	—	—	373	—	373
December 31, 2018	<u>2,117,991</u>	<u>357,009</u>	<u>\$ 239,141</u>	<u>\$ (3,500)</u>	<u>\$373</u>	<u>\$ (367)</u>	<u>\$235,647</u>

See accompanying Notes to Consolidated Financial Statements

SCA ACQUISITION HOLDINGS, LLC  
CONSOLIDATED STATEMENTS OF CASH FLOWS  
(Dollars in thousands)

	Successor For the period April 11, 2018 to December 31, 2018	Predecessor For the period January 1, 2018 to April 10, 2018
<b>Net Income / (Loss)</b>	\$ (367)	\$ 25,910
<b>Adjustments to reconcile Net Income / (Loss) to Cash from Operating Activities:</b>		
Depreciation and Amortization	14,405	2,526
Gain on Asset Transactions, net	(811)	—
Unrealized Loss on Fuel Derivatives	12,006	—
Amortization of Over-market Liabilities	(17,275)	—
Deferred Income Taxes	147	—
Equity-based Compensation Expense	373	—
<b>Changes in Assets and Liabilities:</b>		
Accounts Receivable	20,732	8,148
Due From Predecessor Parent	—	(7,370)
Inventory	156	(293)
Prepaid Expenses	(6,171)	(5,519)
Other Assets	(466)	—
Lessor Maintenance Deposits	(14,193)	(3,148)
Aircraft Lease Deposits	133	(1,151)
Accounts Payable	(9,710)	21,690
Air Traffic Liabilities	20,254	(33,912)
Other Liabilities	(5,448)	(2,298)
<b>Net Cash Provided by Operating Activities</b>	<u>13,764</u>	<u>4,583</u>
<b>Cash Flows from Investing Activities:</b>		
Purchases of Property and Equipment	(78,687)	(2,577)
Purchase of Investments	(5,372)	(118)
Proceeds from the Sale of Investments	3,236	101
<b>Net Cash Used in Investing Activities</b>	<u>(80,823)</u>	<u>(2,594)</u>
<b>Cash Flows from Financing Activities:</b>		
Cash Contributions from Members	47,865	—
Cash Distributions to Member	—	(10,549)
Proceeds from Borrowings	63,341	—
Repayment of Capital Lease Liabilities	(3,160)	(49)
Repayment of Borrowings	(5,854)	(82)
<b>Net Cash Provided by (Used in) Financing Activities</b>	<u>102,193</u>	<u>(10,680)</u>
<b>Net Increase (Decrease) in Cash, Cash Equivalents and Restricted Cash</b>	35,133	(8,691)
<b>Cash, Cash Equivalents and Restricted Cash—Beginning of the Period</b>	8,308	16,999
<b>Cash, Cash Equivalents and Restricted Cash—End of the Period</b>	<u>\$ 43,441</u>	<u>\$ 8,308</u>
<b>Supplemental Disclosures of Cash Flow Information:</b>		
Cash Payments for Interest	\$ 4,364	\$ 402
Cash Payments for Taxes	\$ 11	\$ —
Aircraft and Flight Equipment Acquired through Assumption of Debt	\$ 57,525	\$ —
Aircraft and Flight Equipment Acquired under Capital Lease	\$ 84,773	\$ —
Loans to Members	\$ 3,500	\$ —

[Table of Contents](#)

**SCA ACQUISITION HOLDINGS, LLC**  
**CONSOLIDATED STATEMENTS OF CASH FLOWS**  
**(Dollars in thousands)**

---

The following provides a reconciliation of Cash, Cash Equivalents and Restricted Cash to the amounts reported on the Consolidated Balance Sheet:

	<u>Successor</u> <u>December 31, 2018</u>	<u>Predecessor</u> <u>April 10, 2018</u>
Ending Cash and Equivalents	\$ 29,600	\$ —
Ending Restricted Cash	13,841	8,308
Total Cash, Cash Equivalents and Restricted Cash	<u>\$ 43,441</u>	<u>\$ 8,308</u>

See accompanying Notes to Consolidated Financial Statements

**SCA ACQUISITION HOLDINGS, LLC**

**NOTES TO CONSOLIDATED FINANCIAL STATEMENTS**

**(Dollars in thousands)**

---

**1. COMPANY BACKGROUND**

SCA Acquisition Holdings, LLC (the “Successor”) was formed on December 8, 2017 by funds managed by affiliates of Apollo Global Management (“Apollo”) for the purpose of purchasing (the “Acquisition”) MN Airlines, LLC d/b/a Sun Country Airlines (the “Predecessor”). Except as otherwise stated, the financial information, accounting policies, and activities of the Successor and the Predecessor are referred to as those of the Company (the “Company” or “SCA”).

MN Airlines, LLC is a privately-owned certified air carrier providing scheduled passenger service, charter air transportation and related services. Services are provided to the general public and to wholesale tour operators for air transportation to various U.S. and international destinations. On May 30, 2019, the Company converted its operating entity structure from an LLC to a corporation and now operates as Sun Country, Inc. f/k/a MN Airlines, LLC. The Company operates its fiscal year on a calendar year basis.

**2. BUSINESS COMBINATION**

On April 11, 2018 (the “Acquisition Date”), SCA Acquisition Holdings, LLC acquired 100 percent of MN Airlines’ (“Predecessor Parent”) member interests. The final purchase price, determined in accordance with the definitions and target amounts specified in the sale agreement, was \$187,775. The Company did not incur any material expenses related to the Acquisition prior to the Acquisition Date.

The Acquisition was accounted for as a business combination using the purchase method of accounting, which requires, among other things, that assets acquired and liabilities assumed be recognized on the balance sheet at their fair value as of the Acquisition Date. The fair value of the assets acquired and liabilities assumed were determined using market, income and cost approaches, as described further below. This resulted in a new basis for the assets acquired and liabilities assumed of MN Airlines, LLC as of the Acquisition Date. The Company established a contra-asset after considering the fair value of Lessor Maintenance Reserve Deposits at the time of the sale and concluded that a market participant would not place any value on this asset, as they would need to incur maintenance expense on a dollar for dollar basis to obtain reimbursement from the lessor. The contra-asset represents the Successor’s obligation to perform planned maintenance events on leased aircraft held as of the Acquisition Date. As reimbursable maintenance events are performed and maintenance expense is incurred, the contra-asset is recognized as a reduction to Maintenance expense.

Although the Successor continued with the same core operations after the Acquisition Date, the accompanying consolidated financial statements are presented for two periods: Successor, which relates to the period subsequent to the Acquisition Date, and Predecessor, relating to the period from January 1, 2018 through April 10, 2018. These separate periods are presented to reflect the new basis of accounting as of and subsequent to the Acquisition Date, and have been separated by a vertical line on the face of the consolidated financial statements to highlight the fact that the financial information for such periods has been prepared under a different historical-cost basis of accounting. The Successor’s consolidated financial statements also reflect the funding and recapitalization of the Successor, which occurred at the Acquisition Date.

**Successor** - The accompanying Consolidated Financial Statements include the Successor’s assets, liabilities, and members’ interest and the related income and expenses and cash flows. SCA Acquisition Holdings, LLC had no other operating activities since its formation other than the activities presented of its acquired wholly owned subsidiary, MN Airlines, LLC.

[Table of Contents](#)**SCA ACQUISITION HOLDINGS, LLC****NOTES TO CONSOLIDATED FINANCIAL STATEMENTS****(Dollars in thousands)**

**Predecessor** - The accompanying Predecessor Consolidated Financial Statements include the assets, liabilities, and equity and the related income and expenses and cash flows of MN Airlines, LLC, which occurred prior to the Acquisition Date and are reported under its historical basis that existed prior to the Acquisition Date.

Fair value of the assets acquired and the liabilities assumed as of the Acquisition Date are as follows:

<b>Assets:</b>	
Restricted Cash	\$ 8,308
Investments	3,810
Accounts Receivable	31,796
Inventory	5,295
Prepaid Expenses	7,617
Property and Equipment	38,511
Goodwill	222,223
Intangible Assets	104,000
Aircraft Lease Deposits	17,923
Deferred Tax Asset	49,634
Other Assets	1,071
<b>Total Assets</b>	<b>490,188</b>
<b>Liabilities:</b>	
Accounts Payable	50,016
Accrued Salaries, Wages, and Benefits	9,006
Accrued Transportation Taxes	12,237
Air Traffic Liabilities	72,235
Over-market Liabilities	108,017
Capital Lease Obligations	10,038
Loyalty Program Liabilities	37,165
Long-term Debt	941
Other Liabilities	2,758
<b>Total Liabilities</b>	<b>302,413</b>
<b>Total Purchase Price</b>	<b>\$ 187,775</b>

**Property and Equipment** - The Company acquired Property and Equipment which were valued based on a combination of the cost and market approaches. The cost approach was applied based on inflationary trends to historical costs, considering the age of the asset, its physical condition, operational status and economic utility. The market approach was applied based on market prices for similar assets. The useful lives assigned were based on their expected remaining useful lives consistent with the Company's capitalization policy.

**Sun Country Airlines Tradename** - The Company acquired an intangible asset of \$56,000 assigned to the Sun Country Airlines Tradename. Sun Country has operated under this name and brand since 1983, and has high brand recognition and brand loyalty, particularly in its home market of Minneapolis/St. Paul, MN. This intangible asset was valued using a discounted cash flow analysis based on the relief from royalty method, a variation of the income approach. The relief from royalty approach utilizes certain market information by reference to the amount of after-tax cash flows the Company could generate if the trade names were licensed in an arm's length transaction to a third party. Significant assumptions used in the discounted cash flow analysis

SCA ACQUISITION HOLDINGS, LLC

NOTES TO CONSOLIDATED FINANCIAL STATEMENTS

(Dollars in thousands)

---

include the projected revenue of the Company, the royalty rate, the discount rate and the terminal value. The Company expects to continue to use the brand and associated trademarks for the indefinite future.

**Customer Relationships** - The Company acquired an intangible asset of \$48,000 representing the fair value of its customer relationships arising from Sun Country's extensive charter business, including several large customers with long-term commitments for charter flights. This intangible asset was valued using the multi-period excess earnings method, a variation of the income approach, based on the present value of the expected incremental after-tax cash flows (or "excess earnings") attributable to certain charter customer relationships. Significant assumptions used in the discounted cash flow analysis include the projected earnings of the customer relationships, customer retention rates and the discount rate. The customer relationship intangible asset has been assigned a useful life of 12 years and will be amortized on a straight-line basis over this life.

**Goodwill** - Goodwill, of which \$132,606 was tax deductible, represents the excess of the purchase price over the fair value of the underlying net assets acquired and largely results from expected growth and improved financial results for the Company as well as an assembled workforce, which does not qualify for separate recognition.

**Deferred Tax Asset** - The acquisition of MN Airlines, LLC was treated as an asset acquisition for U.S. federal income tax purposes in which, the Company generally received stepped-up tax basis in assets and liabilities acquired. As a result of fair value adjustments recorded in purchase accounting, the Company recorded a Deferred Tax Asset of \$49,634 related to Air Traffic and Loyalty Liabilities deferred revenue and Over-market Liabilities. The Deferred Tax Asset has been calculated based on the expected federal and state tax rates applicable to the Company.

**Over-market Liabilities** - The Company acquired liabilities related to its over-market lease rates and over-market maintenance reserve payments. Aircraft leases were evaluated using an income approach, based on the present value of the expected differential cash flows between the existing aircraft lease terms as compared to current market lease terms for similar aircraft and market participants. Significant assumptions used in the discounted cash flow analysis include the discount rate and the estimated market lease rates for similar aircraft based on terms commensurate with the Company's credit rating. The Company recognized a liability of \$32,780 representing lease terms which are unfavorable compared with market terms of similar leases and will be amortized into earnings through a reduction of Aircraft Rent on a straight-line basis over the remaining life of each lease.

As of the Acquisition date, Sun Country's existing leases include payments for maintenance reserves in addition to the stated aircraft lease payments. For a substantial portion of these maintenance reserve payments, the Company does not expect to be reimbursed by the lessor. The maintenance reserve payments were evaluated using an income approach, based on the expected differential cash flows between the existing contractual maintenance payments as compared to market terms for similar aircraft under current market assumptions. Significant assumptions used in the discounted cash flow analysis include the discount rate, expected aircraft utilization (impacting the nature and timing of maintenance events) and the estimated market terms for similar aircraft based on terms commensurate with the Company's credit rating. These maintenance reserve payments were deemed unfavorable as a market participant would expect reimbursement based on more favorable terms, indicating that the balance expected not to be reimbursed is unfavorable to the Company. The Company recognized a liability of \$75,238 representing over-market maintenance reserve lease terms compared to market terms of similar leases and will amortize this liability into earnings as a reduction to Aircraft Rent on a straight-line basis over the remaining life of each lease.

**Loyalty Program Liabilities** - The Company acquired liabilities related to frequent flier program obligations. These liabilities were adjusted to their fair value based on stated redemption rates as of the Acquisition Date, less estimated breakage.



SCA ACQUISITION HOLDINGS, LLC

NOTES TO CONSOLIDATED FINANCIAL STATEMENTS

(Dollars in thousands)

---

**3. SUMMARY OF SIGNIFICANT ACCOUNTING POLICIES**

**Principles of Consolidation** - The consolidated financial statements include the accounts of SCA Acquisitions Holdings, SCA-1 Intermediate Aircraft Holding Trust and MN Airlines, LLC d/b/a Sun Country Airlines and have been prepared in accordance with U.S. Generally Accepted Accounting Principles ("GAAP"). All material intercompany balances and transactions have been eliminated in consolidation.

**Use of Estimates** - Preparation of the financial statements in conformity with GAAP requires management to make estimates and assumptions that affect the reported amounts of assets and liabilities and the disclosure of contingent assets and liabilities at the date of the financial statements and the reported amounts of revenues and expenses during the reporting periods. Actual results could differ from those estimates. Significant items subject to such estimates and assumptions include the useful lives of acquired fixed assets, acquired intangibles, maintenance deposits, loyalty program liabilities, valuation of derivative positions and income taxes.

A summary of significant accounting policies consistently applied in the preparation of the accompanying financial statements is as follows:

**Cash and Equivalents** - The Company considers all highly liquid investments with an original maturity of three months or less to be cash equivalents. The Company maintains cash balances at several financial institutions; at times, such balances may be in excess of insurance limits. The Company has not experienced any losses on these balances.

**Restricted Cash** - Charter revenue receipts received prior to the date of transportation are recorded as Restricted Cash and as a component of the Air Traffic Liabilities. DOT regulations require that charter revenue receipts received prior to the date of transportation are maintained in a separate third-party escrow account and the restrictions are released once transportation is provided. This restricted cash is classified in current assets in the consolidated balance sheets as future charter service is provided within 12 months of booking.

**Investments** - Investments consist of certificates of deposit and are recorded at cost, plus accrued interest. The certificates of deposit serve as collateral for letters of credit required by various airports and other vendors. The Company has presented these as Investments on the Consolidated Balance Sheet.

**Accounts Receivable** - Accounts receivables are recorded at the invoiced amount and do not bear interest. Accounts outstanding longer than the contractual payment terms are considered past due. SCA determines its allowances for uncollectible accounts by considering a number of factors, including the length of time accounts receivable are past due, SCA's previous loss history, the customer's current ability to pay its obligation to SCA, and the condition of the general economy and the industry as a whole. No accounts were written off during the periods from April 11, 2018 to December 31, 2018 or from January 1, 2018 to April 10, 2018. As of December 31, 2018, SCA had \$503 as an allowance for doubtful accounts.

**Lessor Maintenance Deposits** - SCA's aircraft lease agreements provide that SCA pay maintenance reserves monthly to aircraft lessors to be held as collateral in advance of major maintenance activities required to be performed by SCA. Maintenance reserve payments are variable based on actual flight hours or cycles. These lease agreements provide that maintenance reserves are reimbursable to SCA upon completion of the maintenance event in an amount equal to the lesser of (1) the amount of the maintenance reserve held by the lessor associated with the specific maintenance event or (2) the qualifying costs related to the specific maintenance event.

**SCA ACQUISITION HOLDINGS, LLC**

**NOTES TO CONSOLIDATED FINANCIAL STATEMENTS**

**(Dollars in thousands)**

---

Maintenance reserve payments that are expected to be recoverable via reimbursable expenses are reflected as Lessor Maintenance Deposits on the accompanying Consolidated Balance Sheet. Amounts not deemed probable of recovery are expensed.

The Company expensed \$12,781 and \$6,003 of maintenance reserve payments during the period April 11, 2018 to December 31, 2018 and from January 1, 2018 to April 10, 2018, respectively. These expenses are reflected in Aircraft Rent on the accompanying Consolidated Statements of Operations. The Company amortized \$11,887 and \$5,388 of the Over-market Liabilities related to maintenance reserves and rent, respectively as a reduction to Aircraft Rent during the period April 11, 2018 to December 31, 2018.

As of December 31, 2018, SCA had maintenance deposits included in Short-term and Long-term Lessor Maintenance Deposits on the accompanying Consolidated Balance Sheet of \$13,958. The Company established a contra-asset to represent the Successor's obligation to perform planned maintenance events on leased aircraft held as of the Acquisition Date. As reimbursable maintenance events are performed and maintenance expense is incurred, the contra-asset is recognized as a reduction to Maintenance expense. As of December 31, 2018, the balance of the contra-asset recorded as of the Acquisition Date was \$65,070. For the period of April 11, 2018 to December 31, 2018, the Company recognized \$6,516 of the contra-asset as a reduction to Maintenance expense on the accompanying Consolidated Statements of Operations.

Subsequent to the Acquisition, the Company entered into five new lease agreements. The lease agreements are structured to allow SCA access to and recover the unused maintenance reserve payments. As such, any maintenance reserve payments related to these lease agreements are probable of being recovered and are reflected as Lessor Maintenance Deposits on the accompanying Consolidated Balance Sheet.

**Inventory** - Parts related to flight equipment, which cannot be economically repaired, reconditioned or reused after removal from the aircraft, are carried at historical cost and charged to operations as consumed. An allowance for obsolescence is provided over the remaining useful life of the related fleet. SCA also provides allowances for parts identified as excess or obsolete to reduce the carrying costs to the lower of cost or net realizable value. These parts are assumed to have an estimated residual value of approximately 10% of the original cost. Inventory balances were net of allowances of \$222 as of December 31, 2018.

**Property and Equipment** - Property and equipment are recorded at cost or fair value at the Acquisition Date and depreciated on a straight-line basis to an estimated residual value over their estimated useful lives or lease term, whichever is shorter, as follows:

Airframes	10-25 years (depending on age)
Engines - Core	7 or 12 years (based on remaining cycles)
Engines - Initial Greentime	1 <sup>st</sup> scheduled maintenance event
Leasehold Improvements, Aircraft, other	3-25 years (or life of lease, if shorter)
Office and Ground Equipment	5-7 years
Computer Hardware and Software	3-5 years
Property and Equipment under Capital Leases	3-25 years (or life of lease, if shorter)
Rotable Parts	6-16 years (average remaining life of aircraft fleet)

SCA ACQUISITION HOLDINGS, LLC

NOTES TO CONSOLIDATED FINANCIAL STATEMENTS

(Dollars in thousands)

---

The Company depreciates Rotable Parts to an estimated residual value using the pooling life method. Depreciation under the pooling life method is calculated over the estimated average useful life of the related aircraft.

Modifications that enhance the operating performance or extend the useful lives of leased airframes are considered leasehold improvements and are capitalized and depreciated over the economic life of the asset or the term of the lease, whichever is shorter.

Capital leases are recorded at net present value of future minimum lease payments.

**Evaluation of Long-Lived Assets** - Long-lived assets, such as Property and Equipment and finite-lived Intangible Assets are reviewed for impairment whenever events or changes in circumstances indicate that the carrying amount of an asset may not be recoverable. If circumstances require a long-lived asset or asset group be tested for possible impairment, the Company first compares undiscounted cash flows expected to be generated by that asset or asset group to its carrying amount. If the carrying amount of the long-lived asset or asset group is not recoverable on an undiscounted cash flow basis, an impairment is recognized to the extent that the carrying amount exceeds its fair value. Fair value is determined using various valuation techniques including discounted cash flow models, quoted market values and third-party independent appraisals, as considered necessary. No impairment losses were recognized during the periods from April 11, 2018 to December 31, 2018 or January 1, 2018 to April 10, 2018.

**Equity Incentive Plan** - The Company recognizes all employee equity-based compensation as expense in the Consolidated Financial Statements over the service period. See Note 8 for further details regarding the Equity Incentive Plan.

**Members' Interest** - As of the Acquisition Date, the Company issued 282,009 shares of Common Stock with no par value. On April 20, 2018, the Company issued an additional 75,000 shares of Common Stock with no par value. The April 20, 2018 shares were partially issued with recourse promissory notes of \$3,500 and are included as Loans to Members on the Consolidated Statements of Changes in Members' Interest.

As of the Acquisition Date, the Company issued 2,117,991 warrants allowing the holder to acquire shares of Common Stock of the Company at the exercise price of \$0.01 per warrant unit at the earlier of permissibility under Foreign Ownership Limitations or transfer to any holder who is a citizen of the United States. The holders of these warrants are not entitled to the full rights of a Stockholder of the Company.

**Goodwill and Intangible Assets** - Goodwill represents the excess purchase price over the estimated fair value of net assets acquired in a business combination. Indefinite-Lived Intangible Assets represents a tradename acquired in a business combination. Goodwill and Indefinite-Lived Intangible Assets must be tested for impairment at least annually if events or changes in circumstances indicate that they might be impaired. Goodwill and Indefinite-Lived Intangible Assets are tested at the reporting unit level.

The Company performed its annual Goodwill and Indefinite-Lived Intangible impairment analysis as of December 31, 2018 and did not recognize an impairment loss as a result of the review. As of December 31, 2018, the Company identified one reporting unit.

Finite-Lived Intangible Assets are amortized over an estimated useful life based on several factors, including the effects of demand, competition, contractual relationship and other business factors. The Company concluded that the Customer Relationships Finite-Lived Intangible Assets has an estimated life of 12 years and is being amortized over this period on a straight-line basis.

**SCA ACQUISITION HOLDINGS, LLC**

**NOTES TO CONSOLIDATED FINANCIAL STATEMENTS**

**(Dollars in thousands)**

---

**Revenue Recognition** - Scheduled passenger service, charter, and certain ancillary revenues including prepaid seat selection fees and baggage fees are recognized when the related service is provided. Certain other operating revenues are recognized as the related services are provided when purchased. Revenues exclude transportation taxes as SCA considers itself an agent for collecting and remitting such taxes.

Non-refundable tickets expire at the date of scheduled travel unless the customer notifies SCA in advance of such date that the customer will not travel. If notification is made, the open ticket can be redeemed for future travel at face value, less a change fee, for up to 12 months after the original date of purchase. A portion of open extended tickets will expire unused. SCA records an estimate for open extended tickets that will expire unused in passenger revenue based on historical experience.

**Frequent Flier Program** - SCA records a liability for points earned by passengers under its Sun Country Rewards program based on the estimated incremental cost of providing free travel for credits that are expected to be redeemed. Incremental costs include fuel, insurance, security, food, beverage, ticketing and facility charges. SCA's Sun Country Rewards program allows for the redemption of points to include payment towards air travel, land travel, taxes, and other ancillary purchases. As of November 3, 2018, SCA changed the name of the program to Sun Country Rewards and modified policies within the program which accelerated point expiration, while making points more valuable for its members. As a result of the program modification the Company recorded a net gain of \$8,463 included in Special Items, net on the Consolidated Statement of Operations during the period from April 11, 2018 to December 31, 2018.

**Co-branded Credit Card Program** - Under SCA's co-branded credit card program, funds received for the marketing of a co-branded Sun Country credit card and delivery of award credits are accounted for as a multiple-deliverable arrangement. At the inception of the arrangement, SCA evaluated all deliverables in the arrangement to determine whether they represent separate units of accounting. SCA determined the arrangement has two separate units of accounting: travel miles to be awarded, and advertising and marketing efforts. Funds received are allocated based on relative selling price. Consideration allocated to the marketing and advertising element is recognized as revenue when earned and recorded in Other Revenue. Consideration allocated to award miles is deferred and recognized ratably as Passenger Revenue over the estimated period the transportation is expected to be provided. Effective July 1, 2018, SCA entered into a new seven-year agreement with its partner, First Bankcard, a division of First National Bank of Omaha, pursuant to a license from Visa, to provide members new and improved benefits. Benefits include 50% discount on seat selection and bag fees, priority boarding, free premium drink during flight, and protects their points from expiring.

**Airframe and Engine Maintenance** - The Predecessor applied the expense as incurred method for maintenance events, where routine maintenance, airframe, and engine overhauls are charged to expense as incurred, except certain costs covered by third-party maintenance agreements, which are charged to expense based on an hourly fee, as defined by the contract.

The Successor elected to adopt the Built-in Overhaul method for significant maintenance costs of owned airframe and engines. Under this method, the value of time remaining until the first scheduled major maintenance event ("greentime") is capitalized and amortized until that first major maintenance event, assuming no residual value. In addition, the value in excess of the greentime is capitalized and amortized over the useful life. These expenses are reported as a component of Depreciation and Amortization on the accompanying Consolidated Statements of Operations. The estimated period until the next scheduled major maintenance event is estimated based on assumptions including estimated cycles, hours, and months, required maintenance intervals, and the age/condition of related parts.

**SCA ACQUISITION HOLDINGS, LLC**

**NOTES TO CONSOLIDATED FINANCIAL STATEMENTS**

**(Dollars in thousands)**

---

Certain SCA aircraft lease agreements contain provisions that require SCA to return aircraft to the lessor in a certain maintenance condition. A liability associated with returning leased aircraft is accrued when incurrence of lease return costs becomes probable. The amount of these costs typically can be estimated near the end of the lease term, after the aircraft has completed its last maintenance cycle prior to being returned.

**Income Taxes** - The Predecessor was a single member limited liability company and was included in the tax filings of its parent company. The Predecessor parent was taxed as a limited liability company that elected to be treated as partnership under the Internal Revenue Code whereby its income or loss is reported by its members. Therefore, no provision for Income Tax Expense was included on the accompanying Consolidated Financial Statements prior to the Acquisition. Subsequent to the acquisition, the Company elected to be treated as a corporation for income tax purposes.

Deferred income taxes are recognized for the tax consequences in future years of differences between the tax bases of assets and liabilities and their financial reporting amounts at each year end based on enacted tax laws and statutory tax rates applicable to the periods in which the differences are expected to affect taxable income. Valuation allowances are established when necessary to reduce Deferred Tax Assets to the amount expected to be realized. All Deferred Tax Assets and Liabilities, along with any related valuation allowance, are classified as noncurrent on the balance sheet. Interest and penalties on uncertain tax positions, to the extent they exist, are included in the Company's provision for income taxes. The provision for income taxes represents the current tax expense for the period and the change during the period in Deferred Tax Assets and Liabilities.

*Unaudited Pro Forma Income Tax Information* - The unaudited pro forma information presents an income tax provision for the Predecessor period as though the Company had elected to be treated as a corporation for federal and state income tax purposes for the period January 1, 2018 through April 10, 2018. The following table presents the computation of the pro forma income tax expense:

	<u>Predecessor</u>
Income before income tax	\$ 25,910
Pro forma income tax rate	23.30%
Pro forma income tax expense	\$ 6,036

**Concentration Risk** - Approximately 27% of the Company's Accounts Receivable balances as of December 31, 2018, were from major financial institutions for tickets purchased via credit cards. One financial institution accounted for approximately 20% of the Company's Accounts Receivable balance as of December 31, 2018.

Approximately 48% of the Company's fuel purchases were made from two vendors for the year ended December 31, 2018.

Approximately 53% of the Company's workforce were under union contracts as of December 31, 2018 with three different unions; Air Line Pilots Association ("ALPA"), International Brotherhood of Teamsters ("IBT") and Transport Workers Union ("TWU"). Approximately 58% of the Company's workforce are under union contracts that will be expiring within a year.

[Table of Contents](#)

**SCA ACQUISITION HOLDINGS, LLC**  
**CONSOLIDATED STATEMENTS OF CASH FLOWS**  
**(Dollars in thousands)**

---

The following table shows the Company's airline employee groups represented by unions:

<u>Employee Group</u>	<u>Number of Active Employees Represented</u>	<u>Union</u>	<u>Date on which Collective Bargaining Agreement Becomes Amendable</u>
Sun Country Pilots	342	ALPA	October 31, 2020
Sun Country Flight Attendants	456	IBT	December 31, 2019
Sun Country Dispatchers	21	TWU	September 30, 2017 *

\* currently open and under negotiation

**Recent Accounting Standards**

*Revenue from Contracts with Customers* - In May 2014, the Financial Accounting Standards Board ("FASB") issued Accounting Standards Update ("ASU") 2014-09, *Revenue from Contracts with Customers* ("New Revenue Standard"). This update is a comprehensive new revenue recognition model that requires a company to recognize revenue to depict the transfer of goods or services to customers in an amount that reflects the consideration to which the entity expects to be entitled in exchange for those goods or services. The Company will adopt the standard using the modified retrospective method effective January 1, 2019.

The adoption of the New Revenue Standard will impact the Company's accounting for outstanding loyalty points earned through travel by SCA loyalty program members. There is no change in accounting for sales of loyalty points to our co-branded card partner as those are currently reported in accordance with the New Revenue Standard. Through December 31, 2018, the Company used the incremental cost method to account for the portion of the loyalty program liability related to points earned through travel, which were valued based on the estimated incremental cost of carrying one additional passenger. The New Revenue Standard requires the Company to change to the deferred revenue method and apply a relative selling price approach whereby a portion of each passenger ticket sale attributable to loyalty points earned is deferred and recognized in passenger revenue upon future redemption.

The New Revenue Standard will also require certain reclassifications, principally the reclassification of certain ancillary revenues previously classified and reported as Other Revenue to Passenger Revenue. In addition, certain fees previously recognized when incurred by the customer will be deferred and recognized as revenue when passenger travel is provided.

Upon adoption of the standard on January 1, 2019 the Company will make an adjustment to reduce Retained Earnings by \$3,359.

*Leases* - In February 2016, the FASB issued ASU 2016-02, *Leases*. Under the new guidance, lessees will be required to recognize the following for all leases (with the exception of short-term leases) at the commencement date: (1) A lease liability, which is a lessee's obligation to make lease payments arising from a lease, measured on a discounted basis; and (2) A right-of-use asset, which is an asset that represents the lessee's right to use, or control the use of, a specified asset for the lease term. The amendments in this ASU are effective for fiscal years beginning after December 15, 2019. The Company elected to early adopt the standard effective January 1, 2019 using the modified retrospective adoption method.

## SCA ACQUISITION HOLDINGS, LLC

## NOTES TO CONSOLIDATED FINANCIAL STATEMENTS

(Dollars in thousands)

Upon adoption of the standard on January 1, 2019 the Company will record a Right-of-Use Asset of \$178,577 and a Lease Liability of \$204,790 on the Consolidated Balance Sheet.

*Classification of Certain Cash Receipts and Cash Payments* – In November of 2016, the FASB issued ASU 2016-18, *Statement of Cash Flows (Topic 230): Restricted Cash*. This update clarifies how entities should present restricted cash and restricted cash equivalents in the statement of cash flows. ASU 2016-18 requires entities to show the changes in the total of cash, cash equivalents, restricted cash and restricted cash equivalents in the statement of cash flows. As a result, entities will no longer present transfers between cash and cash equivalents and restricted cash and restricted cash equivalents in the statement of cash flows. The Company adopted this ASU effective January 1, 2018 and the Consolidated Statements of Cash Flows for 2018 reflect the application of these requirements. A reconciliation of Cash and Restricted Cash reported on the Consolidated Statements of Cash Flows to the amounts reported on our Consolidated Balance Sheets is provided in a table below the Consolidated Statements of Cash Flows.

**4. EARNINGS PER SHARE**

Basic earnings per share, which excludes dilution, is computed by dividing Net Income / (Loss) available to common stockholders by the weighted average number of common shares outstanding for the period.

Diluted earnings per share reflects the potential dilution that could occur if securities or other contracts to issue common stock were exercised or converted into common stock. The number of incremental shares from the assumed issuance of shares relating to share based awards is calculated by applying the treasury stock method.

The following table shows the computation of basic and diluted earnings per share (in thousands, except per share amounts):

	<u>Successor</u> <u>For the period</u> <u>April 11, 2018 to</u> <u>December 31, 2018</u>	<u>Predecessor</u> <u>For the period</u> <u>January 1, 2018 to</u> <u>April 10, 2018</u>
<b>Numerator:</b>		
Net Income / (Loss)	\$ (367)	\$ 25,910
<b>Denominator:</b>		
Weighted Average Common Shares / Units Outstanding - Basic	2,472	100,000
Dilutive effects of Stock Options (1)	—	—
Weighted Average Common Shares / Units Outstanding - Diluted	2,472	100,000
Basic earnings per share	\$ (0.15)	\$ 0.26
Diluted earnings per share	\$ (0.15)	\$ 0.26

(1) The Company has excluded 118,780 time-based and 189,740 performance-based options from the calculation of diluted EPS for the period April 11, 2018 to December 31, 2018. In loss periods, the inclusion of unvested options would have an anti-dilutive effect.

Outstanding warrants have been included in basic and dilutive weighted average shares outstanding as they are equity classified, have an exercise price of \$0.01, and all necessary conditions for issuance have been met.

**SCA ACQUISITION HOLDINGS, LLC****NOTES TO CONSOLIDATED FINANCIAL STATEMENTS****(Dollars in thousands)****5. PROPERTY AND EQUIPMENT**

As of December 31, 2018, the Company had two spare engines (one owned and one financed through operating lease) and 30 aircraft; three owned, five financed through capital leases, and 22 financed through operating leases, with lease terms from 4 to 12 years. See Note 13 for further details on leases.

The Accumulated Depreciation on owned assets was \$6,359 as of December 31, 2018. The related depreciation expense was \$6,731 and \$2,315 for the period April 11, 2018 through December 31, 2018 and the period January 1, 2018 through April 10, 2018, respectively.

The Accumulated Amortization on Capital Leased Assets was \$4,476 as of December 31, 2018. The related amortization expense was \$4,476 and \$119 for the period April 11, 2018 through December 31, 2018 and the period January 1, 2018 through April 10, 2018, respectively. Amortization is classified in Depreciation and Amortization on the Consolidated Statements of Operations.

**6. GOODWILL AND INTANGIBLE ASSETS**

Components of Goodwill and Intangible Assets were as follows (in thousands):

	<b>December 31, 2018</b>		
	<u>Gross Carrying Amount</u>	<u>Accumulated Amortization</u>	<u>Net Carrying Value</u>
Goodwill	\$ 222,223	\$ —	\$ 222,223
Intangible Assets with Finite Lives:			
Customer Relationships	48,000	(2,890)	45,110
Intangible Assets with Indefinite Lives:			
Tradename	56,000	—	56,000
Total Intangible Assets	<u>104,000</u>	<u>(2,890)</u>	<u>101,110</u>
Total Goodwill and Intangible Assets	<u>\$ 326,223</u>	<u>\$ (2,890)</u>	<u>\$ 323,333</u>

SCA recognized \$2,890 of amortization expense during the period April 11, 2018 to December 31, 2018 and none during the period from January 1, 2018 to April 10, 2018. Amortization is classified in Depreciation and Amortization on the Consolidated Statements of Operations. As of December 31, 2018, estimated annual amortization expense for each of the next five fiscal years is \$4,000 and \$25,110 thereafter.

**7. FINANCING AGREEMENTS**

**Lines of Credit** - In November 2012, SCA entered into a \$5,000 revolving credit agreement with a financial institution. Outstanding balances bore interest at either a) the prime commercial rate plus an applicable margin or b) the London Interbank Offered Rate plus an applicable margin, as more fully defined in the agreement. SCA paid a 0.375% commitment fee on the average daily unused balance. The revolving credit agreement was secured by certain assets of SCA and contained financial covenants related to capital lease obligations, fixed operating rentals and earnings before interest, taxes, depreciation and amortization ("EBITDA"), as defined, as well as guarantees from the Predecessor's parent and its owners. This revolving credit agreement ceased on April 10, 2018.

The Company entered into a revolving credit agreement with a financial institution with funds becoming available on the Acquisition Date. This agreement provides available credit based upon defined thresholds to a



## SCA ACQUISITION HOLDINGS, LLC

## NOTES TO CONSOLIDATED FINANCIAL STATEMENTS

(Dollars in thousands)

maximum amount of \$20,000. Available credit under this agreement as of December 31, 2018 was limited to \$16,008 which was reduced by outstanding letters of credit totaling \$350. Outstanding balances bear interest at the greatest of a) the Prime Rate or b) the Federal Funds Effective Rate plus 0.5% or c) the Adjusted London Interbank Offered Rate (“LIBOR”) for an Interest Period of one-month plus 1.00%. SCA pays a 0.5% commitment fee on the average daily unused balance. The revolving credit agreement is secured by certain assets of SCA and contains a financial covenant and guarantees. SCA was in compliance with the covenant as of December 31, 2018. As of December 31, 2018, there were no outstanding balances on the revolving credit agreement. The interest rate as of December 31, 2018 was 6.5%.

**Long Term Debt** – The Successor entered into a series of promissory note agreements with original loan amounts totaling \$59,342 to purchase aircraft and flight equipment. Each promissory note bears an interest rate of 8.45%, has a five-year term with principal and interest payments due monthly and a lump sum payment due at the end.

Long-term Debt included the following (in thousands):

	<u>Successor</u> <u>December 31,</u> <u>2018</u>
Note payable to Wilmington Trust Company dated October 2018, with an original loan amount of \$23,146 payable in monthly installments of \$275 through September 2023, and then a final lump sum payment of \$6,944 in October 2023. This note bears interest at an annual rate of 8.45% and is secured by the equipment for which the loan was used.	\$ 22,597
Note payable to Wilmington Trust Company dated October 2018, with an original loan amount of \$16,106 payable in monthly installments of \$191 through September 2023, and then final lump sum payment of \$4,832 in October 2023. This note bears interest at an annual rate of 8.45% and is secured by the equipment for which the loan was used.	15,723
Note payable to Wilmington Trust Company dated November 2018, with an original loan amount of \$3,671 payable in monthly installments of \$44 through October 2023, and then final lump sum payment of \$1,101 in November 2023. This note bears interest at an annual rate of 8.45% and is secured by the equipment for which the loan was used.	3,627
Note payable to Wilmington Trust Company dated November 2018, with an original loan amount of \$16,419 payable in monthly installments of \$195 through October 2023, and then final lump sum payment of \$4,926 in November 2023. This note bears interest at an annual rate of 8.45% and is secured by the equipment for which the loan was used.	16,214
Notes payable to Riverland Bank dated between April 2015 and May 2016, with original loan amounts totaling \$734 payable in monthly installments with expirations between April 2020 and April 2021. The notes bear interest at an annual rate of 5.15% and is secured by the equipment for which the loan was used.	268
Total Debt	58,429
Less: Current Maturities of Long-term Debt	<u>(8,606)</u>
Total Long-term Debt	<u>\$ 49,823</u>

**SCA ACQUISITION HOLDINGS, LLC**

**NOTES TO CONSOLIDATED FINANCIAL STATEMENTS**

**(Dollars in thousands)**

Future maturities of the outstanding Debt are as follows (in thousands):

Years Ending December 31	
2019	\$ 8,606
2020	8,545
2021	8,463
2022	8,449
2023	<u>24,366</u>
Total	<u>\$ 58,429</u>

**8. EQUITY INCENTIVE PLAN**

In October of 2018, the Company adopted an equity incentive plan (the “Plan”) pursuant to which the Company may grant stock options, restricted stock, and restricted stock units to employees, consultants, and non-employee directors. Shares related to awards granted under the Plan that expire, are forfeited, or for any other reason are not issued or delivered will be available for subsequent awards under the Plan. The Plan authorizes issuance of up to 369,828 shares. As of December 31, 2018, there were 61,308 shares available for future grants.

On November 7, 2018, the Company granted 308,520 stock options to certain employees, with 38.5% of the options vesting upon the passage of time, and 61.5% of the options vesting based on performance conditions. The time-based options vest proportionally (25% per year) on each of the first four anniversaries of the Acquisition. The performance-based options vest when there is a Change in Control, according to the Non-Qualified Stock Option Agreement. Forfeitures are recognized as they occur. All options awarded under the Plan expire on the tenth anniversary of the grant date.

Compensation expense related to time-based stock options is recognized in an amount equal to the fair value on the date of the grant and is recognized over the employee’s requisite service period, generally the vesting period of the award. Compensation expense related to performance-based stock options is recognized if the performance condition becomes probable of occurring.

A summary of stock option activity:

	For the period April 11, 2018 to December 31, 2018		
	Time-Based Stock Options		
	Number of shares	Weighted average exercise price per share	Weighted average remaining contractual term (years)
Outstanding as of April 11, 2018	—	\$ —	—
Granted	118,780	\$100.00	10.0
Exercised	—	—	—
Forfeited	—	—	—
Expired	—	—	—
Outstanding as of December 31, 2018	<u>118,780</u>	<u>\$100.00</u>	<u>9.8</u>
Exercisable as of December 31, 2018	—	\$ —	—
Vested or expected to vest, December 31, 2018	<u>118,780</u>	<u>\$100.00</u>	<u>9.8</u>

SCA ACQUISITION HOLDINGS, LLC

NOTES TO CONSOLIDATED FINANCIAL STATEMENTS

(Dollars in thousands)

	For the period April 11, 2018 to December 31, 2018		
	Performance-Based Stock Options		
	Number of shares	Weighted average exercise price per share	Weighted average remaining contractual term (years)
Outstanding as of April 11, 2018	—	\$ —	—
Granted	189,740	\$100.00	10.0
Exercised	—	—	—
Forfeited	—	—	—
Expired	—	—	—
Outstanding as of December 31, 2018	<u>189,740</u>	<u>\$100.00</u>	<u>9.8</u>
Exercisable as of December 31, 2018	—	\$ —	—
Vested or expected to vest, December 31, 2018	—	\$ —	—

The weighted-average grant date fair value of the stock options granted during the period April 11, 2018 through December 31, 2018 was \$45.12 and \$28.28 per share for the time-based and performance-based options, respectively. The associated stock compensation expense related to the time-based options of \$373 was recorded during the period. As of December 31, 2018, there was \$4,986 of total unrecognized compensation expense related to stock options, which is expected to be fully recognized over a weighted average period of approximately 3.3 years.

A third-party valuation advisor was utilized to assist management in determining the fair value of options granted using the Black-Scholes option-pricing model based on the grant price and assumptions regarding the expected term, expected volatility, dividends, and risk-free interest rates. The grant price was determined based on the fair value of the Company's stock on the grant date.

The fair value of the time-based stock options granted during 2018 was estimated using the Black-Scholes option-pricing model with the following weighted-average assumptions used for grants:

	2018
Expected Term	6.25 years
Expected Volatility	44.3%
Risk-free Interest Rate	2.9%
Expected Dividend Yield	—

The expected term was based on vesting criteria and time to expiration. The expected volatility was based on historical volatility of stock prices and assets of a public company peer group. The risk-free interest rate was based on the implied risk-free rate using the expected term and yields of U.S Treasury stock and S&P bond yields.

The fair value of the performance-based stock options granted during 2018 was estimated by simulating the future stock price using geometric brownian motion and risk-free rate of return at intervals specified in the grant agreement. The number of shares vested and future price at each interval were recorded for each simulation and then multiplied together and discounted to present value at the risk-free rate of return.

**SCA ACQUISITION HOLDINGS, LLC**

**NOTES TO CONSOLIDATED FINANCIAL STATEMENTS**

**(Dollars in thousands)**

---

**9. FUEL DERIVATIVE**

The Company's operations are inherently dependent upon the price of aircraft fuel. To manage economic risks associated with fluctuations in aircraft fuel prices, the Company periodically enters into fuel option and swap contracts. The Company does not apply hedge accounting to its fuel derivative contracts, nor does it hold or issue them for trading purposes.

Fuel derivative contracts are recognized at fair value on the Consolidated Balance Sheet as Derivative Assets, if the fair value is in an asset position, or as Derivative Liabilities, if the fair value is in a liability position. The Company's portfolio value of fuel derivative contracts was \$12,006 of Derivative Liabilities as of December 31, 2018. The Company did not have any collateral held by counterparties to these agreements as of December 31, 2018.

Unrealized loss on fuel derivatives was \$12,006 for the period April 11, 2018 through December 31, 2018, and none for the period January 1, 2018 through April 10, 2018. Fuel derivative expenses are classified in Aircraft Fuel on the Consolidated Statements of Operations.

The cash premiums paid for fuel derivative positions was \$2,280 for the period April 11, 2018 through December 31, 2018, and none for the period January 1, 2018 through April 10, 2018.

There were no fuel derivative contract settlements during the reporting period. As of December 31, 2018, the Company had outstanding fuel derivative contracts covering 50.1 million gallons of crude oil that will all be settled during 2019.

**10. FAIR VALUE OF ASSETS AND LIABILITIES**

Accounting standards define fair value as the exchange price that would be received for an asset or paid to transfer a liability (an exit price) in the principal or most advantageous market for the asset or liability in an orderly transaction between market participants on the measurement date. The standards also establish a fair value hierarchy, which requires an entity to maximize the use of observable inputs and minimize the use of unobservable inputs when measuring fair value. There are three levels of inputs that may be used to measure fair value:

Level 1 – Quoted prices for identical assets or liabilities in active markets.

Level 2 – Observable inputs other than Level 1 prices, such as quoted prices for similar assets or liabilities in active markets; quoted prices for identical or similar assets or liabilities in markets that are not active; or other inputs that are observable or can be corroborated by observable market data for substantially the full term of the assets or liabilities.

Level 3 – Unobservable inputs that are supported by little or no market activity and that are significant to the fair value of the assets or liabilities.

The Company uses the following valuation methodologies for financial instruments measured at fair value on a recurring basis.

**Derivative Instruments** – Derivative instruments are accounted for as either assets or liabilities and are carried at fair value. The fair value for fuel derivative options and swaps is determined utilizing an option pricing model that uses inputs that are readily available in active markets or can be derived from information available in active markets and are classified within Level 2.

## SCA ACQUISITION HOLDINGS, LLC

## NOTES TO CONSOLIDATED FINANCIAL STATEMENTS

(Dollars in thousands)

The following table summarizes the assets and liabilities measured at fair value on a recurring basis (in thousands):

	December 31, 2018			Total
	Level 1	Level 2	Level 3	
Assets	\$ —	\$ —	\$ —	\$ —
Liabilities				
Fuel Derivative Contracts	—	12,006	—	12,006
Total Liabilities measured at fair value on a recurring basis	<u>\$ —</u>	<u>\$12,006</u>	<u>\$ —</u>	<u>\$12,006</u>

Certain assets are measured at fair value on a nonrecurring basis. The Company's non-financial assets, which primarily consist of property and equipment, intangible assets and goodwill are not required to be measured at fair value on a recurring basis and are reported at carrying value. However, on a periodic basis whenever events or changes in circumstances indicate that their carrying may not be recoverable, non-financial assets are assessed for impairment and, if applicable, written down to fair value using significant unobservable inputs, classified as Level 3.

The Company's debt portfolio consists of fixed-rate notes payable, the majority of which were entered into during October and November 2018 and are carried at cost. Cost approximates fair value based on similar borrowing rates as of December 31, 2018.

**11. INCOME TAX**

As of the Acquisition date of April 11, 2018, the Company elected to be treated as a corporation for income tax purposes. Prior to the acquisition, the Company was treated as a partnership and therefore no Predecessor 2018 amounts are shown.

The following table summarizes the significant components of the provision for income taxes from continuing operations (in thousands):

	Successor For the period April 11, 2018 to December 31, 2018
Current:	
Federal	\$ —
State and Local	—
Total Current Tax expense	—
Deferred:	
Federal	129
State and Local	32
Total Deferred Tax Expense	161
Total Income Tax Expense	<u>\$ 161</u>

## SCA ACQUISITION HOLDINGS, LLC

## NOTES TO CONSOLIDATED FINANCIAL STATEMENTS

(Dollars in thousands)

The income tax provision differs from that computed at the federal statutory corporate tax rate as follows:

	<u>Successor</u> <u>For the period</u> <u>April 11, 2018 to</u> <u>December 31, 2018</u>
Expected Provision at Federal Statutory Tax Rate	21.0%
State Tax Expense, net of Federal Benefit	(12.0%)
Meals and Entertainment	(42.9%)
Employee Parking	(40.4%)
Other Permanent Adjustments	(3.6%)
Total Income Tax Expense	<u>(77.9%)</u>

The following table summarizes the significant components of the Company's deferred taxes (in thousands):

	<u>Successor</u> <u>December 31, 2018</u>
<b>Deferred Tax Assets:</b>	
Capital Lease Obligations	\$ 21,576
Goodwill and Intangible Assets	15,964
Net Operating Loss	19,451
Accrued Maintenance	12,439
Accrued Over-market Rent	6,346
Loyalty Program Liabilities	5,392
Unrealized Loss on Fuel Derivatives	3,357
Other	2,673
Total Deferred Tax Assets	<u>87,198</u>
<b>Deferred Tax Liabilities:</b>	
Capital Lease Obligations	(21,671)
Property and Equipment	(16,040)
Total Deferred Tax Liabilities	<u>(37,711)</u>
Total Net Deferred Tax Assets	<u>\$ 49,487</u>

As of December 31, 2018, the Company has \$18,745 of federal net operating loss and \$706 of state net operating loss, net of tax effect, available that may be applied against future tax liabilities. There is no expiration of federal net operating losses. The state net operating losses begin to expire in 2029.

In assessing the realizability of Deferred Tax Assets, management considers whether it is more likely than not that some portion or all the Deferred Tax Assets will not be realized. The ultimate realization of the Deferred Tax Assets is dependent upon the generation of future taxable income during periods in which the temporary differences become deductible. Management considers the scheduled reversal of the liabilities (including the impact of available carryback and carryforward periods), projected future taxable income, and tax-planning strategies in making this assessment. As of December 31, 2018, management believes that it is more likely than not that the future results of the operations will generate sufficient taxable income to realize the tax benefits related to its Deferred Tax Assets.

**SCA ACQUISITION HOLDINGS, LLC**

**NOTES TO CONSOLIDATED FINANCIAL STATEMENTS**

**(Dollars in thousands)**

---

The Company recognizes the consolidated financial statement effect of a tax position when it is more likely than not, based on the technical merits, that the position will be sustained upon examination. If applicable, the Company reports both accrued interest and penalties related to unrecognized tax benefits as a component of Income Tax Expense in the Consolidated Statements of Operations.

As of December 31, 2018, the Company had no unrecognized tax benefits recorded in its Consolidated Balance Sheet.

The Company files income tax returns in the United States and various states. In the normal course of business, the Company is subject to potential income tax examination by the federal and state tax authorities in these jurisdictions for tax years that are open under local statute. For U.S. federal and state income tax purposes, the Company's 2018 tax returns remain open to examination.

**12. EMPLOYEE BENEFIT PLANS**

SCA has a 401(k) profit-sharing retirement plan covering substantially all employees. The plan allows employee contributions up to 50% of a participant's eligible compensation, subject to limits established under the 401(k) plan and annual IRS elective deferral limits. SCA currently matches 100% of participants contribution up to a maximum of 4% for non-pilot participants' and 6% for pilot participants' eligible compensation and the plan allows for a discretionary Company contribution. The Company made cash contributions of approximately \$592 and \$308 for the period April 11, 2018 through December 31, 2018, and the period January 1, 2018 through April 10, 2018, respectively. The Company made discretionary contributions of approximately \$2,436 and \$1,026 for the period April 11, 2018 through December 31, 2018, and the period January 1, 2018 through April 10, 2018, respectively. Contributions are classified in Salaries, Wages, and Benefits on the Consolidated Statements of Operations.

**13. LEASES**

As of December 31, 2018, the Company had lease commitments for 19 Boeing 737 aircraft under long-term operating lease agreements expiring at various dates through December 2026. Security deposits totaling \$13,160 were outstanding in connection with these leases as of December 31, 2018. As of December 31, 2018, the Company also had outstanding security deposits totaling \$2,500 related to five capital lease agreements. There were additional outstanding security deposits totaling \$1,440 related to long-term lease agreements that were pending as of December 31, 2018. Security deposits are included in Aircraft Lease Deposits on the Consolidated Balance Sheet and are to be refunded upon expiration of the lease, subject to certain equipment return conditions. These leases require the Company to pay related insurance, property taxes, aircraft maintenance, and, in many cases, airframe and engine overhaul costs. In addition, certain of the Company's aircraft leases contain purchase options.

As of December 31, 2018, the Company also had three Boeing 737 aircraft under seasonal short-term operating lease agreements expiring in April 2019. These leases have similar terms and requirements as the long-term leases. Security deposits totaling approximately \$600 were outstanding in connection with these leases as of December 31, 2018. Security deposits totaling approximately \$90 were outstanding in connection with short-term engine leases as of December 31, 2018. Deposits on short-term leases to date have been returned to the Company within 30 days of the expiration of the respective lease, subject to certain equipment return conditions.

The Company conducts operations from leased real properties that include land, offices, and catering facilities from nonrelated parties. These leases expire at various dates through 2029. Rent expense related to these leases

## SCA ACQUISITION HOLDINGS, LLC

## NOTES TO CONSOLIDATED FINANCIAL STATEMENTS

(Dollars in thousands)

was approximately \$3,229 and \$1,471 for the period April 11, 2018 through December 31, 2018, and the period January 1, 2018 through April 10, 2018, respectively. In addition, certain of the Company's real estate leases contain options to extend the term.

The Company records rent expense on a straight-line basis. In addition to basic rent charges, the Company is responsible for various operating, maintenance and insurance costs.

A schedule of future minimum lease payments as of December 31, 2018 is as follows (in thousands):

Years Ending December 31	Capital Leases	Aircraft Operating Leases	Other Leases
2019	\$ 13,866	\$ 51,375	\$ 5,249
2020	14,092	35,925	4,546
2021	14,092	32,842	4,354
2022	14,092	32,842	4,099
2023	14,092	32,592	2,622
Thereafter	65,909	42,954	11,822
Total Minimum Lease Payments	136,143	\$228,530	\$32,692
Less: Amount Representing Interest	(44,326)		
Present Value of Minimum Lease Payments	91,817		
Less: Short-term Capital Lease Obligations	(6,115)		
Long-term Capital Lease Obligations	\$ 85,702		

**14. SPECIAL ITEMS**

**Special Items, net** - The Company recognized \$8,463 for the period April 11, 2018 through December 31, 2018 as a net reduction to expense associated with changes to the terms of the Sun Country Rewards program, see Note 3 for further description. In addition, the Company recognized \$1,757 and \$271 of expense for the period April 11, 2018 through December 31, 2018, and the period January 1, 2018 through April 10, 2018, respectively, related to early-out payments and other expenses incurred in connection with outsourcing certain operations and other employee initiatives. These efforts were primarily related to airport station, flight attendants and ground handling employees.

**15. RELATED PARTIES**

**Predecessor** - In 2012, the Company executed a revolving promissory note receivable with the Predecessor's parent. Under the agreement, the Company advanced funds to the related party. In return, the Company received interest on the unpaid balance. The revolving promissory note receivable agreement expired on December 31, 2017 and was extended to December 31, 2018. The note and the related party guarantee were terminated as of April 10, 2018. Related party interest income was \$0 and \$92 for the period April 11, 2018 through December 31, 2018, and the period January 1, 2018 through April 10, 2018, respectively.

Although no longer a related party as of April 11, 2018, the Company continues to lease office space from the previously related party, and the lease extends through 2020. Rent expense related to this lease was \$584 and \$316 for the period April 11, 2018 through December 31, 2018, and the period January 1, 2018 through April 10, 2018, respectively.



**SCA ACQUISITION HOLDINGS, LLC****NOTES TO CONSOLIDATED FINANCIAL STATEMENTS****(Dollars in thousands)**

**Successor** – The Company reimburses Apollo for out-of-pocket expenses incurred related to Company matters.

**16. CONTINGENCIES**

The Company is subject to various legal proceedings in the normal course of business and records legal costs as incurred. Management believes these proceedings will not have a materially adverse effect on the Company.

**17. OPERATING SEGMENTS AND GEOGRAPHIC INFORMATION**

The Company is managed as a single business unit that provides air transportation for passengers. The Company's chief operating decision maker makes resource allocation decisions to maximize the Company's consolidated financial results. Managing the Company as one segment allows management the opportunity to maximize the value of its route network.

The Company attributes operating revenues by geographic region based upon the origin of each passenger flight segment.

The Company's operations are highly concentrated in the U.S. but include service to many international locations, primarily based on scheduled service to Latin America during the winter season and on military charter services. The Company measures its operating revenues by geographic region as defined by the Department of Transportation ("DOT") for airline reporting.

	<u>Successor</u> For the period April 11, 2018 to December 31, 2018	<u>Predecessor</u> For the period January 1, 2018 to April 10, 2018
Domestic	\$ 368,456	\$ 173,995
Latin America	15,628	23,003
Other	847	454
Total	\$ 384,931	\$ 197,452

Substantially all the Company's tangible assets are located in the U.S. or relates to flight equipment, which is mobile across geographic markets and, therefore, considered to be domestic.

**18. EVENT (UNAUDITED) SUBSEQUENT TO THE DATE OF THE INDEPENDENT AUDITORS' REPORT**

In connection with the reissuance of the Consolidated Financial Statements, the Company has evaluated subsequent events through February 5, 2020, the date the financial statements were available to be reissued.

**Amazon Agreement**

On December 13, 2019, the Company signed a six-year contract (with two, two-year extension options, for a maximum term of 10 years) with Amazon.com Services, Inc. (together with its affiliates, "Amazon") to provide them with air cargo services. Amazon will supply the aircraft and bear directly or reimburse us for certain operating expenses, including fuel and heavy maintenance. The aircraft will fly under the Company's air carrier operating certificate and the Company will supply the crew, maintenance and insurance for the aircraft. Amazon will pay a fixed monthly fee per aircraft as well as a set rate per block hour flown.

**SCA ACQUISITION HOLDINGS, LLC**

**NOTES TO CONSOLIDATED FINANCIAL STATEMENTS**

**(Dollars in thousands)**

---

In connection with the agreement, the Company issued to Amazon warrants to purchase an aggregate of 502,028 shares of common stock at an exercise price of \$286.46 per share. One percent of the warrants vested upon issuance and incremental tranches will vest upon certain milestones of aggregate global payments by Amazon or its affiliates to the Company up to a total of \$1.12 billion of aggregate payments. Any unvested warrants will become vested upon a change of control or certain transfers of 30% or more of the voting power in the Company to a new person or group (other than an initial public offering or any follow-on equity offering by the Company or SCA Horus Holdings, LLC, an affiliate of certain investment funds managed by Apollo, pursuant to an effective registration statement, so long as no person or group acquires more than 50% of the voting power of the Company in such offering). To the extent any Amazon warrants were not previously exercised, and if the fair market value of the Company's common stock is greater than the warrant exercise price, the unexercised warrants will be automatically net exercised immediately before their expiration. As is the case for investment in the Company, the exercise of the warrants is limited by restrictions imposed by federal law on foreign ownership and control of U.S. airlines.

Flying under the agreement is expected to begin in the second quarter of 2020.

**Reorganization Transactions**

On January 31, 2020, all the outstanding Apollo Warrants were exercised to purchase common stock of SCA Acquisition Holdings, LLC. On January 31, 2020, SCA Acquisition Holdings, LLC was converted into a Delaware corporation pursuant to a statutory conversion and changed its name to Sun Country Airlines Holdings, Inc. In connection with the conversion to a corporation, all of the outstanding shares of SCA Acquisition Holdings, LLC common stock were converted into shares of Sun Country Airlines Holdings, Inc. common stock, the outstanding warrants held by Amazon to purchase shares of SCA Acquisition Holdings, LLC common stock were converted into warrants to purchase shares of Sun Country Airlines Holdings, Inc. common stock and all of the outstanding options to purchase shares of SCA Acquisition Holdings, LLC common stock were converted into options to purchase shares of Sun Country Airlines Holdings, Inc. common stock.

\* \* \* \* \*

[Table of Contents](#)

SCA ACQUISITION HOLDINGS, LLC  
CONDENSED CONSOLIDATED BALANCE SHEETS  
(Dollars in thousands)  
(unaudited)

	<u>September 30, 2019</u>	<u>December 31, 2018</u>
<b>ASSETS</b>		
<b>Current Assets:</b>		
Cash and Equivalents	\$ 15,804	\$ 29,600
Restricted Cash	15,453	13,841
Investments	5,836	5,947
Accounts Receivable, net of an allowance for doubtful accounts of \$395 and \$503, respectively	20,950	11,064
Short-term Lessor Maintenance Deposits	4,102	2,873
Inventory, net of a reserve for obsolescence of \$479 and \$222, respectively	5,013	4,830
Prepaid Expenses	7,614	12,796
Other Current Assets	880	467
Total Current Assets	<u>75,652</u>	<u>81,418</u>
<b>Property &amp; Equipment, net:</b>		
Aircraft and Flight Equipment	114,658	83,990
Leasehold Improvements and Ground Equipment	10,714	6,354
Computer Hardware and Software	9,040	5,691
Finance Lease Assets (note 12)	168,678	96,696
Rotable Parts	8,966	8,760
Property & Equipment	<u>312,056</u>	<u>201,491</u>
Accumulated Depreciation & Amortization	<u>(31,518)</u>	<u>(10,835)</u>
Total Property & Equipment, net	280,538	190,656
<b>Other Assets:</b>		
Goodwill (note 6)	222,223	222,223
Intangible Assets, net (note 6)	98,110	101,110
Operating Lease Right-of-use Assets (note 12)	155,932	—
Aircraft Lease Deposits	19,175	17,790
Long-term Lessor Maintenance Deposits	23,235	11,085
Deferred Tax Asset (note 10)	38,094	49,487
Other Assets	2,192	2,063
Total Other Assets	<u>558,961</u>	<u>403,758</u>
Total Assets	<u>\$ 915,151</u>	<u>\$ 675,832</u>

See accompanying Notes to Condensed Consolidated Financial Statements

[Table of Contents](#)

**SCA ACQUISITION HOLDINGS, LLC**  
**CONDENSED CONSOLIDATED BALANCE SHEETS**  
**(Dollars in thousands)**  
**(unaudited)**

	<u>September 30, 2019</u>	<u>December 31, 2018</u>
<b>LIABILITIES AND STOCKHOLDERS' EQUITY</b>		
<b>Current Liabilities:</b>		
Accounts Payable	\$ 39,219	\$ 28,669
Accrued Salaries, Wages, and Benefits	15,383	14,148
Accrued Transportation Taxes	8,520	10,370
Air Traffic Liabilities	90,549	105,705
Derivative Liabilities (note 8)	1,430	12,006
Over-market Liabilities	11,086	21,449
Finance Lease Obligations (note 12)	11,239	6,115
Loyalty Program Liabilities	13,849	13,166
Operating Lease Obligations (note 12)	33,439	—
Current Maturities of Long-term Debt (note 7)	10,387	8,606
Other Current Liabilities	2,394	2,690
Total Current Liabilities	<u>237,495</u>	<u>222,924</u>
<b>Long-term Liabilities:</b>		
Over-market Liabilities	39,595	68,138
Finance Lease Obligations (note 12)	147,695	85,702
Loyalty Program Liabilities	10,179	10,784
Operating Lease Obligations (note 12)	148,437	—
Long-term Debt (note 7)	53,870	49,823
Other Long-term Liabilities	3,113	2,814
Total Long-term Liabilities	<u>402,889</u>	<u>217,261</u>
Total Liabilities	640,384	440,185
<b>Stockholders' Equity:</b>		
Stockholders' Equity	239,141	239,141
Common stock with no par value; 5,000,000 shares authorized, 360,009 and 357,009 shares issued at September 30, 2019 and December 31, 2018, respectively		
Warrants to acquire common stock at an exercise price of \$0.01 per share were 2,117,991 at September 30, 2019 and December 31, 2018		
Loans to Stockholders	(3,500)	(3,500)
Additional Paid In Capital	1,916	373
Retained Earnings	37,210	(367)
Total Stockholders' Equity	<u>274,767</u>	<u>235,647</u>
Total Liabilities and Stockholders' Equity	<u>\$ 915,151</u>	<u>\$ 675,832</u>

See accompanying Notes to Condensed Consolidated Financial Statements

[Table of Contents](#)
**SCA ACQUISITION HOLDINGS, LLC**
**CONDENSED CONSOLIDATED STATEMENTS OF OPERATIONS**
**(Dollars in thousands, except per share amounts)**
**(unaudited)**

	Successor		Predecessor
	For the Nine Months Ended September 30, 2019	For the Period April 11, 2018 to September 30, 2018	For the Period January 1, 2018 to April 10, 2018
<b>Operating Revenues:</b>			
Passenger	\$ 527,327	\$ 219,244	\$ 172,897
Other	10,193	29,414	24,555
Total Operating Revenue	<u>537,520</u>	<u>248,658</u>	<u>197,452</u>
<b>Operating Expenses:</b>			
Aircraft Fuel	127,338	67,390	45,790
Salaries, Wages, and Benefits	105,668	57,114	36,964
Aircraft Rent	37,959	23,543	28,329
Maintenance	25,041	10,116	9,508
Sales and Marketing	27,414	10,465	10,854
Depreciation and Amortization	25,371	8,250	2,526
Ground Handling	31,009	14,686	8,619
Landing Fees and Airport Rent	33,730	16,139	10,481
Special Items, net	6,378	1,757	271
Other Operating, net	51,094	22,889	17,994
Total Operating Expenses	<u>471,002</u>	<u>232,349</u>	<u>171,336</u>
Operating Income	<u>66,518</u>	<u>16,309</u>	<u>26,116</u>
<b>Non-operating Expense:</b>			
Interest Income	618	118	96
Interest Expense	(12,700)	(2,823)	(339)
Other, net	(906)	(2,170)	37
Total Non-operating Expense	<u>(12,988)</u>	<u>(4,875)</u>	<u>(206)</u>
Income before Income Tax	<u>53,530</u>	<u>11,434</u>	<u>25,910</u>
Income Tax Expense	12,476	2,783	—
Net Income	<u>\$ 41,054</u>	<u>\$ 8,651</u>	<u>\$ 25,910</u>
Net Income per share to common stockholders:			
Basic	<u>\$ 16.58</u>	<u>\$ 3.50</u>	<u>\$ 0.26</u>
Diluted	<u>\$ 16.22</u>	<u>\$ 3.50</u>	<u>\$ 0.26</u>
Shares / Units used for computation:			
Basic	2,476	2,471	100,000
Diluted	2,531	2,471	100,000
Pro Forma Income Tax Expense			\$ 6,036
Pro Forma Net Income			\$ 19,874
Pro Forma Net Income per unit to Member:			
Basic and diluted			\$ 0.20
Pro Forma units used for computation:			
Basic and diluted			100,000

See accompanying Notes to Condensed Consolidated Financial Statements

SCA ACQUISITION HOLDINGS, LLC

CONDENSED CONSOLIDATED STATEMENTS OF CHANGES IN STOCKHOLDERS' EQUITY

(Dollars in thousands)

(unaudited)

Nine Months Ended September 30, 2018

Predecessor

	<u>Units</u>	<u>Total</u>
January 1, 2018	100,000,000	\$ 34,422
Net Income	—	25,910
Distributions to Stockholder	—	(10,549)
April 10, 2018	<u>100,000,000</u>	<u>\$ 49,783</u>

Successor

	<u>Warrants</u>	<u>Shares</u>	<u>Capital Contribution</u>	<u>Loans to Stockholders</u>	<u>APIC</u>	<u>Retained Earnings</u>	<u>Total</u>
Capital at Purchase on April 11, 2018 - Warrants	2,117,991	—	\$ 165,711	\$ —	\$ —	\$ —	\$ 165,711
Capital at Purchase on April 11, 2018 - Shares	—	282,009	22,064	—	—	—	22,064
Additional Capital Contribution	—	—	43,865	—	—	—	43,865
Stockholders Capital Contribution	—	75,000	7,500	(3,500)	—	—	4,000
Net Income	—	—	—	—	—	8,651	8,651
September 30, 2018	<u>2,117,991</u>	<u>357,009</u>	<u>\$ 239,141</u>	<u>\$(3,500)</u>	<u>\$ —</u>	<u>\$ 8,651</u>	<u>\$ 244,292</u>

Successor

	<u>Warrants</u>	<u>Shares</u>	<u>Capital Contribution</u>	<u>Loans to Stockholders</u>	<u>APIC</u>	<u>Retained Earnings</u>	<u>Total</u>
December 31, 2018	<u>2,117,991</u>	<u>357,009</u>	<u>\$ 239,141</u>	<u>\$(3,500)</u>	<u>\$ 373</u>	<u>\$(367)</u>	<u>\$ 235,647</u>
Cummulative effect of New Revenue Standard	—	—	—	—	—	(3,477)	(3,477)
Shares Granted to Stockholders	—	3,000	—	—	—	—	—
Net Income	—	—	—	—	—	41,054	41,054
Equity-based Compensation	—	—	—	—	1,543	—	1,543
September 30, 2019	<u>2,117,991</u>	<u>360,009</u>	<u>\$ 239,141</u>	<u>\$(3,500)</u>	<u>\$ 1,916</u>	<u>\$ 37,210</u>	<u>\$ 274,767</u>

See accompanying Notes to Condensed Consolidated Financial Statements

SCA ACQUISITION HOLDINGS, LLC  
**CONDENSED CONSOLIDATED STATEMENTS OF CASH FLOWS**  
(Dollars in thousands)  
(unaudited)

	Successor		Predecessor
	For the Nine Months Ended September 30, 2019	For the Period April 11, 2018 to September 30, 2018	For the Period January 1, 2018 to April 10, 2018
<b>Net Income</b>	\$ 41,054	\$ 8,651	\$ 25,910
<b>Adjustments to reconcile Net Income to Cash from Operating Activities:</b>			
Depreciation and Amortization	25,371	8,250	2,526
Amortization of ROU Asset	28,955	—	—
Loss on Asset Transactions, net	264	—	—
Unrealized Gain on Fuel Derivatives	(6,894)	(1,895)	—
Amortization of Over-market Liabilities	(10,721)	(11,478)	—
Deferred Income Taxes	12,428	2,769	—
Equity-based Compensation Expense	1,543	—	—
<b>Changes in Assets and Liabilities:</b>			
Accounts Receivable	(9,885)	19,590	8,148
Due From Predecessor Parent	—	—	(7,370)
Inventory	(495)	480	(293)
Prepaid Expenses	2,381	(1,114)	(5,519)
Other Assets	(543)	(786)	—
Lessor Maintenance Deposits	(14,274)	(8,757)	(3,148)
Aircraft Lease Deposits	(1,385)	743	(1,151)
Accounts Payable	8,951	(12,473)	21,690
Air Traffic Liabilities	(15,157)	9,494	(33,841)
Loyalty Liabilities	(4,434)	(6,039)	(71)
Operating Lease Obligations	(29,667)	—	—
Other Liabilities	(1,838)	(14,888)	(2,298)
<b>Net Cash Provided by (Used in) Operating Activities</b>	<u>25,654</u>	<u>(7,453)</u>	<u>4,583</u>
<b>Cash Flows from Investing Activities:</b>			
Purchases of Property & Equipment	(37,111)	(16,612)	(2,577)
Purchase of Investments	(2,198)	(3,441)	(118)
Proceeds from the Sale of Investments	2,308	328	101
<b>Net Cash Used in Investing Activities</b>	<u>(37,001)</u>	<u>(19,725)</u>	<u>(2,594)</u>
<b>Cash Flows from Financing Activities:</b>			
Cash Contributions from Stockholders	—	47,865	—
Cash Distributions to Stockholder	—	—	(10,549)
Proceeds from Borrowings	13,350	4,000	—
Repayment of Financing Lease Obligations	(6,665)	(1,624)	(49)
Repayment of Borrowings	(7,522)	(636)	(82)
<b>Net Cash Provided by (Used in) Financing Activities</b>	<u>(837)</u>	<u>49,605</u>	<u>(10,680)</u>
<b>Net Increase (Decrease) in Cash, Cash Equivalents and Restricted Cash</b>	<u>(12,184)</u>	<u>22,427</u>	<u>(8,691)</u>
<b>Cash, Cash Equivalents and Restricted Cash—Beginning of the Period</b>	<u>43,441</u>	<u>8,308</u>	<u>16,999</u>
<b>Cash, Cash Equivalents and Restricted Cash—End of the Period</b>	<u>\$ 31,257</u>	<u>\$ 30,735</u>	<u>\$ 8,308</u>
<b>Supplemental information:</b>			
Cash Payments for Interest	\$ 12,332	\$ 2,138	\$ 402
Cash Payments for Taxes	\$ 381	\$ 11	\$ —
<b>Non-cash transactions:</b>			
Aircraft and Flight Equipment Acquired under Finance Lease	\$ 71,982	\$ 84,773	\$ —
Loans to Stockholders	\$ —	\$ 3,500	\$ —
Purchases of Property & Equipment in Accounts Payable	\$ 1,595	\$ —	\$ —

**SCA ACQUISITION HOLDINGS, LLC**  
**CONDENSED CONSOLIDATED STATEMENTS OF CASH FLOWS**  
**(Dollars in thousands)**  
**(unaudited)**

---

The following provides a reconciliation of Cash, Cash Equivalents and Restricted Cash to the amounts reported on the Condensed Consolidated Balance Sheet:

	<u>Successor</u>		<u>Predecessor</u>
	<u>September 30, 2019</u>	<u>September 30, 2018</u>	<u>April 10, 2018</u>
Ending Cash and Equivalents	\$ 15,804	\$ 16,739	\$ —
Ending Restricted Cash	15,453	13,996	8,308
Total Cash, Cash Equivalents and Restricted Cash	<u>\$ 31,257</u>	<u>\$ 30,735</u>	<u>\$ 8,308</u>

See accompanying Notes to Condensed Consolidated Financial Statements



**SCA ACQUISITION HOLDINGS, LLC****NOTES TO CONDENSED CONSOLIDATED FINANCIAL STATEMENTS****(Dollars in thousands)****(unaudited)****1. BASIS OF PRESENTATION AND RECENT ACCOUNTING PRONOUNCEMENTS**

SCA Acquisition Holdings, LLC (the “Successor”) was formed on December 8, 2017 by funds controlled by Apollo Global Management for the purpose of purchasing (the “Acquisition”) MN Airlines, LLC d/b/a Sun Country Airlines (the “Predecessor”). Except as otherwise stated, the financial information, accounting policies, and activities of the Successor and the Predecessor are referred to as those of the Company (the “Company” or “SCA”).

Sun Country, Inc. f/k/a MN Airlines, LLC, is a privately-owned certified air carrier providing scheduled passenger service, charter air transportation and related services. Services are provided to the general public and to wholesale tour operators for air transportation to various U.S. and international destinations. On May 30, 2019, the Company converted its operating entity structure from MN Airlines, LLC to a corporation and now operates as Sun Country, Inc. f/k/a MN Airlines, LLC. The Company operates its fiscal year on a calendar year basis.

The condensed consolidated financial statements include the accounts of SCA Acquisitions Holdings, LLC, SCA-1 Intermediate Aircraft Holding Trust and Sun Country, Inc. d/b/a Sun Country Airlines and have been prepared in accordance with U.S. Generally Accepted Accounting Principles (“GAAP”). All material intercompany balances and transactions have been eliminated in consolidation.

On April 11, 2018 (the “Acquisition Date”), SCA Acquisition Holdings, LLC acquired 100 percent of MN Airlines’ stockholder equity. Although the Company continued as the same operating entity after the Acquisition, the accompanying condensed consolidated statements of operations and cash flows for the year ended December 31, 2018 are presented for two periods: Predecessor and Successor, which relate to the period preceding the Acquisition and the period succeeding the Acquisition. The Acquisition and the allocation of the purchase price have been recorded as of April 11, 2018, see Note 2 for further information.

Management believes the accompanying unaudited Condensed Consolidated Financial Statements reflect all adjustments, including normal recurring items, considered necessary for a fair statement of results for the interim periods presented. The interim results reflected in the unaudited Condensed Consolidated Financial Statements are not necessarily indicative of the results that may be expected for other interim periods or for the full year. SCA is subject to seasonal fluctuations as demand is generally greater in the first quarter of each year. The Condensed Consolidated Balance Sheet as of December 31, 2018 was derived from audited annual consolidated financial statements but does not contain all of the footnote disclosures from the annual consolidated financial statements.

*Pro Forma Income Tax Information* - The pro forma information presents an income tax provision for the Predecessor period as though the Company had elected to be treated as a corporation for federal and state income tax purposes for the period January 1, 2018 through April 10, 2018. The following table presents the computation of the pro forma income tax expense:

	<u>Predecessor</u>
Income before income tax	\$ 25,910
Pro forma income tax rate	23.30%
Pro forma income tax expense	\$ 6,036

**Recently Adopted Accounting Standards**

*Revenue from Contracts with Customers* - In May 2014, the Financial Accounting Standards Board (“FASB”) issued Accounting Standards Update (“ASU”) 2014-09, *Revenue from Contracts with Customers* (“New Revenue

**SCA ACQUISITION HOLDINGS, LLC**

**NOTES TO CONDENSED CONSOLIDATED FINANCIAL STATEMENTS**

**(Dollars in thousands)**

**(unaudited)**

---

Standard”) (Topic 606). This update is a comprehensive new revenue recognition model that requires a company to recognize revenue to depict the transfer of goods or services to customers in an amount that reflects the consideration to which the entity expects to be entitled in exchange for those goods or services. The Company adopted the standard using the modified retrospective method effective January 1, 2019.

The adoption of the New Revenue Standard impacts the Company’s accounting for outstanding loyalty points earned through travel by SCA loyalty program members. There is no change in accounting for sales of loyalty points to our co-branded card partner as those are currently reported in accordance with the New Revenue Standard. Through December 31, 2018, the Company used the incremental cost method to account for the portion of the loyalty program liability related to points earned through travel, which were valued based on the estimated incremental cost of carrying one additional passenger. The New Revenue Standard required the Company to change to the deferred revenue method and apply a relative standalone selling price approach whereby a portion of each passenger ticket sale attributable to loyalty points earned is deferred and recognized in passenger revenue upon future redemption.

Upon adoption of the New Revenue Standard, the Company reclassified certain ancillary revenues from Other Revenue to Passenger Revenue. In addition, certain fees previously recognized when incurred by the customer are deferred and recognized as revenue when passenger travel is provided.

Upon adoption of the standard on January 1, 2019 the Company made an adjustment to reduce Retained Earnings by \$3,477.

*Leases* - In February 2016, the FASB issued ASU 2016-02, *Leases* (Topic 842) (“ASC 842”). Under the new guidance, lessees are required to recognize the following for all leases (with the exception of short-term leases) at the commencement date: (1) A lease liability, which is a lessee’s obligation to make lease payments arising from a lease, measured on a discounted basis; and (2) A right-of-use asset, which is an asset that represents the lessee’s right to use, or control the use of, a specified asset for the lease term. The Company elected to early adopt the standard effective January 1, 2019 using the modified retrospective adoption method.

Upon adoption of the standard on January 1, 2019 the Company recorded an Operating Lease Right-of-Use (“ROU”) Asset of \$178,577 (net of balance sheet reclassifications) and Operating Lease Liabilities of \$204,790 on the Condensed Consolidated Balance Sheet. The ROU Asset includes amounts reclassified from Over-market Liabilities and Prepaid Rent.

**Recently Issued Accounting Standards**

In June 2016, the FASB issued ASU 2016-13, *Financial Instruments - Credit Losses* (Topic 326): *Measurement of Credit Losses on Financial Instruments*. The update requires the use of an “expected loss” model on certain types of financial instruments and requires consideration of a broader range of reasonable and supportable information to calculate credit loss estimates. For trade receivables, loans and held-to-maturity debt securities, entities will be required to estimate lifetime expected credit losses. For available-for-sale debt securities, entities will be required to recognize an allowance for credit losses rather than a reduction to the carrying value of the asset. ASU 2016-13 was initially effective for non-public companies for fiscal years and interim periods beginning after December 15, 2021, with early adoption is permitted. In November 2019, the FASB issued ASU 2019-10, *Financial Instruments-Credit Losses (Topic 326), Derivatives and Hedging (Topic 815), and Leases (Topic 842): Effective Dates*, which delayed the effective date for certain entities, such as the Company,

**SCA ACQUISITION HOLDINGS, LLC**

**NOTES TO CONDENSED CONSOLIDATED FINANCIAL STATEMENTS**

**(Dollars in thousands)**

**(unaudited)**

---

to apply ASU 2016-13 until fiscal years and interim periods beginning after December 15, 2022. The Company is still evaluating the impact of ASU 2016-13.

**2. BUSINESS COMBINATION**

On the Acquisition Date, SCA Acquisition Holdings, LLC acquired 100 percent of MN Airlines' stockholder equity. The final purchase price, determined in accordance with the definitions and target amounts specified in the sale agreement, was \$187,775. The Company did not incur any material expenses related to the Acquisition prior to the Acquisition Date.

The Acquisition was accounted for as a business combination using the purchase method of accounting, which requires, among other things, that assets acquired and liabilities assumed be recognized on the balance sheet at their fair value as of the Acquisition Date. The fair value of the assets acquired and liabilities assumed were determined using market, income and cost approaches. This resulted in a new basis for the assets acquired and liabilities assumed of MN Airlines, LLC as of the Acquisition Date. The Company established a contra-asset after considering the fair value of Lessor Maintenance Deposits at the time of the sale and concluded that a market participant would not place any value on this asset, as they would need to incur maintenance expense on a dollar for dollar basis to obtain reimbursement from the lessor. The contra-asset represents the Successor's obligation to perform planned maintenance events on leased aircraft held as of the Acquisition Date. As reimbursable maintenance events are performed and maintenance expense is incurred, the contra-asset is recognized as a reduction to Maintenance expense.

Although the Successor continued with the same core operations after the Acquisition Date, the accompanying condensed consolidated financial statements are presented for two fiscal 2018 periods: Successor, which relates to the fiscal 2018 period subsequent to the Acquisition Date, and Predecessor, relating to the period from January 1, 2018 through April 10, 2018. These separate periods are presented to reflect the new basis of accounting as of and subsequent to the Acquisition Date, and have been separated by a vertical line on the face of the Condensed Consolidated Financial Statements to highlight the fact that the financial information for such periods has been prepared under a different historical-cost basis of accounting. The Successor's Condensed Consolidated Financial Statements also reflect the funding and recapitalization of the Successor, which occurred at the Acquisition Date.

**Successor** - The accompanying Successor Condensed Consolidated Financial Statements include the Successor's assets, liabilities, and stockholders' equity and the related income and expenses and cash flows. SCA Acquisition Holdings, LLC had no other operating activities since its formation other than the activities presented of its acquired wholly owned subsidiary, Sun Country, Inc., f/k/a MN Airlines, LLC.

**Predecessor** - The accompanying Predecessor Condensed Consolidated Financial Statements include the assets, liabilities, and equity and the related income and expenses and cash flows of Sun Country, Inc., f/k/a MN Airlines, LLC, which occurred prior to the Acquisition Date and are reported under its historical basis that existed prior to the Acquisition Date.

## SCA ACQUISITION HOLDINGS, LLC

## NOTES TO CONDENSED CONSOLIDATED FINANCIAL STATEMENTS

(Dollars in thousands)

(unaudited)

Fair value of the assets acquired and the liabilities assumed as of the Acquisition Date were as follows (dollars in thousands):

<b>Assets:</b>	
Restricted Cash	\$ 8,308
Investments	3,810
Accounts Receivable	31,796
Inventory	5,295
Prepaid Expenses	7,617
Property and Equipment	38,511
Goodwill	222,223
Intangible Assets	104,000
Aircraft Lease Deposits	17,923
Deferred Tax Asset	49,634
Other Assets	1,071
<b>Total Assets</b>	<b>490,188</b>
<b>Liabilities:</b>	
Accounts Payable	50,016
Accrued Salaries, Wages, and Benefits	9,006
Accrued Transportation Taxes	12,237
Air Traffic Liabilities	72,235
Over-market Liabilities	108,017
Capital Lease Obligations	10,038
Loyalty Program Liabilities	37,165
Long-term Debt	941
Other Liabilities	2,758
<b>Total Liabilities</b>	<b>302,413</b>
<b>Total Purchase Price</b>	<b>\$ 187,775</b>

**Property and Equipment** - The Company acquired Property and Equipment which were valued based on a combination of cost and income approaches. The useful lives assigned were based on their expected remaining useful lives consistent with the Company's capitalization policy.

**Sun Country Airlines Tradename** - The Company acquired an intangible asset of \$56,000 assigned to the Sun Country Airlines Tradename. Sun Country has operated under this name and brand since 1983, and has high brand recognition and brand loyalty, particularly in its home market of Minneapolis/St. Paul, MN. The Company expects to continue to use the brand and associated trademarks for the indefinite future. This intangible asset was valued using the relief from royalty method of the income approach.

**Customer Relationships** - The Company acquired an intangible asset of \$48,000 representing the fair value of its customer relationships arising from Sun Country's extensive charter business, including several large customers with long-term commitments for charter flights. This intangible asset was valued using the multi-period excess earnings method, a variation of the income approach. The customer relationship intangible asset has been assigned a useful life of 12 years and will be amortized on a straight-line basis over this life.

SCA ACQUISITION HOLDINGS, LLC

NOTES TO CONDENSED CONSOLIDATED FINANCIAL STATEMENTS

(Dollars in thousands)

(unaudited)

---

**Goodwill** - Goodwill, of which \$132,606 was tax deductible, represents the excess of the purchase price over the fair value of the underlying net assets acquired and largely results from expected growth and improved financial results for the Company as well as an assembled workforce, which does not qualify for separate recognition.

**Deferred Tax Asset** - The acquisition of MN Airlines, LLC was treated as an asset acquisition for U.S. federal income tax purposes in which, the Company generally received stepped-up tax basis in assets and liabilities acquired. As a result of fair value adjustments recorded in purchase accounting, the Company recorded a Deferred Tax Asset of \$49,634 related to Air Traffic and Loyalty Liabilities deferred revenue and Over-market Liabilities. The Deferred Tax Asset has been calculated based on the expected federal and state tax rates applicable to the Company.

**Over-market Liabilities** - The Company acquired liabilities related to its over-market lease rates and over-market maintenance reserve payments. Aircraft leases were evaluated using an income approach. The Company recognized a liability of \$32,779 representing lease terms which are unfavorable compared with market terms of similar leases and will be amortized into earnings through a reduction of Aircraft Rent on a straight-line basis over the remaining life of each lease. With the adoption of ASC 842 the Company reclassified this liability to be included in the ROU asset.

As of the Acquisition date, Sun Country's existing leases include payments for maintenance reserves in addition to the stated aircraft lease payments. For a substantial portion of these maintenance reserve payments, the Company does not expect to be reimbursed by the lessor. The maintenance reserve payments not expected to be reimbursed were evaluated using an income approach. These maintenance reserve payments were deemed unfavorable as a market participant would expect reimbursement based on a more favorable return provision, so the balance expected not to be reimbursed is unfavorable to the Company. The Company recognized a liability of \$75,238 representing over-market maintenance reserve lease terms compared to market terms of similar leases and will amortize this liability into earnings as a reduction to Aircraft Rent on a straight-line basis over the remaining life of each lease.

**Loyalty Program Liabilities** - The Company acquired liabilities related to frequent flier program obligations. These liabilities were adjusted to their fair value based on stated redemption rates, less estimated breakage.

### 3. REVENUE

Sun Country, Inc. is a certified air carrier generating Operating Revenues from Scheduled service, Charter service, Ancillary and Other. Scheduled service revenue consists of base fares, unused and expired passenger credits and other expired travel credits. Charter service revenue consists of revenue earned from SCA charter operations, primarily generated through service provided to the U.S Department of Defense, collegiate and professional sports teams and casinos. Ancillary revenues consist of revenue earned from air travel-related services such as baggage fees, seat selection and upgrade fees, itinerary service fees, on-board sales and sales of trip insurance. Other revenue consists primarily of revenue from services in connection with our Sun Country Vacation products, including organizing ground services, such as hotel, car and transfers. Other revenue also includes services not directly related to providing passenger services such as the advertising, marketing and brand elements resulting from our co-branded credit card program. In addition, Other revenues also include revenue from mail and cargo operations through the use of cargo space on regularly scheduled passenger aircraft.

Services are provided to the general public and to wholesale tour operators for air transportation to numerous U.S. and international destinations.

## SCA ACQUISITION HOLDINGS, LLC

## NOTES TO CONDENSED CONSOLIDATED FINANCIAL STATEMENTS

(Dollars in thousands)

(unaudited)

The adoption of ASC 606 resulted in a charge to January 1, 2019 retained earnings of \$3,477 impacting the financial statement line items as follows:

	<u>December 31, 2018</u> <u>(As Reported)</u>	<u>Impact of ASC 606</u> <u>Adoption</u>	<u>January 1, 2019</u>
<b>ASSETS</b>			
<b>Other Assets:</b>			
Deferred Tax Asset	\$ 49,487	\$ 1,036	\$ 50,523
<b>LIABILITIES AND STOCKHOLDERS' EQUITY</b>			
<b>Current Liabilities:</b>			
Air Traffic Liabilities	\$ 105,705	\$ (354)	\$ 105,351
Loyalty Program Liabilities	\$ 13,166	\$ 4,867	\$ 18,033
<b>Stockholders' Equity:</b>			
Retained Earnings	\$ (367)	\$ (3,477)	\$ (3,844)

The impact to revenue due to the adoption of ASC 606 was a decrease of \$3,750 for the nine months ended September 30, 2019. Income tax expense decreased due to the adoption of ASC 606 by \$861 for the nine months ended September 30, 2019. The table below summarizes the impact of the adoption on the Condensed Consolidated Statements of Operations for the nine months ended September 30, 2019:

	<u>Nine months ended September 30, 2019</u>		
	<u>Under ASC 605</u>	<u>Impact of Adoption</u>	<u>Under ASC 606</u>
Operating Revenue	\$ 541,270	\$ (3,750)	\$ 537,520
Operating Expenses	471,002	—	471,002
Operating Income	70,268	(3,750)	66,518
Non-operating Expense	(12,988)	—	(12,988)
Income before Income Tax	57,280	(3,750)	53,530
Income Tax Expense	13,337	(861)	12,476
Net Income	<u>\$ 43,943</u>	<u>\$ (2,889)</u>	<u>\$ 41,054</u>
Net Income per share to common stockholders:			
Diluted	<u>\$ 17.36</u>	<u>\$ (1.14)</u>	<u>\$ 16.22</u>

SCA ACQUISITION HOLDINGS, LLC

NOTES TO CONDENSED CONSOLIDATED FINANCIAL STATEMENTS

(Dollars in thousands)

(unaudited)

The significant categories comprising Operating Revenues are as follows:

	Successor		Predecessor
	For the Nine Months Ended September 30, 2019	For the Period April 11, 2018 to September 30, 2018	For the Period January 1, 2018 to April 10, 2018
<b>Operating Revenues:</b>			
Scheduled service	\$ 312,493	\$ 147,130	\$ 132,234
Charter service	125,715	72,114	40,663
Ancillary (1)	89,119	—	—
Passenger	527,327	219,244	172,897
Ancillary (1)	—	24,870	15,670
Other	10,193	4,544	8,885
Other	10,193	29,414	24,555
Total Operating Revenue	<u>\$ 537,520</u>	<u>\$ 248,658</u>	<u>\$ 197,452</u>

(1) The classification of Ancillary changed as a result of the adoption of ASC 606.

The Company's contracts with its customers primarily consist of its tickets sold, which are initially deferred as Air Traffic Liabilities. Revenue is primarily recognized when the performance obligation to the customer is satisfied, which is primarily when travel is provided.

The Company attributes and measures its Operating Revenue by geographic region as defined by the Department of Transportation for airline reporting based upon the origin of each passenger flight segment.

The Company's operations are highly concentrated in the U.S. but include service to many international locations, primarily based on scheduled service to Latin America during the winter season and on military charter services.

Total Operating Revenue by geographic region are as follows:

	Successor		Predecessor
	For the Nine Months Ended September 30, 2019	For the Period April 11, 2018 to September 30, 2018	For the Period January 1, 2018 to April 10, 2018
Domestic	\$ 506,505	\$ 229,213	\$ 173,995
Latin America	30,262	18,898	23,003
Other	753	547	454
Total Operating Revenue	<u>\$ 537,520</u>	<u>\$ 248,658</u>	<u>\$ 197,452</u>

**Contract Balances**

The Company's significant contract liabilities are comprised of (1) ticket sales for transportation that has not yet been provided (reported as Air Traffic Liabilities on the Condensed Consolidated Balance Sheets) and

**SCA ACQUISITION HOLDINGS, LLC****NOTES TO CONDENSED CONSOLIDATED FINANCIAL STATEMENTS****(Dollars in thousands)****(unaudited)**

(2) outstanding loyalty program reward credits that may be redeemed for future travel and other non-air travel award (reported as Loyalty Program Liabilities on the Condensed Consolidated Balance Sheets).

	<u>September 30, 2019</u>	<u>December 31, 2018</u>
Air Traffic Liabilities	\$ 90,549	\$ 105,705
Loyalty Program Liabilities	24,028	23,950
Total Contract Liabilities	<u>\$ 114,577</u>	<u>\$ 129,655</u>

The Air Traffic Liability principally represents tickets sold for future travel on Sun Country. The balance in the Air Traffic Liabilities fluctuates with seasonal travel patterns. Most tickets can be purchased no more than nine months in advance, therefore any revenue associated with tickets sold for future travel will be recognized within that timeframe. For the nine months ended September 30, 2019, \$104,974 of revenue was recognized in Passenger Revenue that was included in the Air Traffic Liabilities as of December 31, 2018.

**Loyalty Program**

The Company historically used the incremental cost method for its frequent flier program, formerly UFly Rewards. After the Acquisition, the Company retained the incremental cost method for reward points earned post acquisition but applied fair value to points that are redeemed but were earned prior to the acquisition, as the points were recorded at fair value on the Acquisition Date. The January 1, 2019 adjustment to increase the Loyalty Liabilities for the ASC 606 adoption was \$4,867, which marked the earned loyalty points to fair value.

The Company allocates a portion of the selling price of each ticket used by a Sun Country Rewards member as the measure of fair value for the expected future redemption of the reward points. The liability is increased in each accounting period to reflect reward points that are earned and is reduced for the points used, incorporating estimated breakage.

The Company also participates in a co-branded credit card that enables card users to earn Sun Country Rewards points. Funds received for the marketing of a co-branded Sun Country credit card and delivery of loyalty program reward points are accounted for as a multiple-deliverable arrangement. The Company determined that the arrangement has two separate units of accounting: reward points to be awarded and marketing efforts. Funds received from the co-branded provider are allocated based on relative standalone selling price of these deliverables. Consideration allocated to the marketing and advertising element is earned as the co-branded card is used and recorded in Other Revenues.

The balance of the Loyalty Program Liabilities fluctuates based on seasonal patterns, which impact the volume of point credits issued through travel or sold to co-branded credit card and other partners (deferral of revenue) and point credits redeemed (recognition of revenue).



SCA ACQUISITION HOLDINGS, LLC

NOTES TO CONDENSED CONSOLIDATED FINANCIAL STATEMENTS

(Dollars in thousands)

(unaudited)

Changes in the Loyalty Program Liabilities are as follows:

	<u>2019</u>
Balance - December 31, 2018 (1)	\$23,950
ASC 606 adoption adjustment (January 1, 2019)	4,867
Point Credits Earned (1)	5,132
Travel Point Credits Redeemed	(9,921)
Balance - September 30, 2019	<u>\$24,028</u>

- (1) Principally relates to revenue recognized from the redemption of point credits for both air and non-air travel awards. Point credits are combined in one homogenous pool and are not separately identifiable. As such, the revenue is comprised of points that were part of the loyalty program deferred revenue balance at the beginning of the period, as well as points that were earned during the period.

The timing of point redemptions can vary significantly, however the majority of new points are redeemed within two years.

**4. EARNINGS PER SHARE**

Basic earnings per share, which excludes dilution, is computed by dividing Net Income available to common stockholders by the weighted average number of common shares outstanding for the period.

Diluted earnings per share reflects the potential dilution that could occur if securities or other contracts to issue common stock were exercised or converted into common stock. The number of incremental shares from the assumed issuance of shares relating to share based awards is calculated by applying the treasury stock method.

The following table shows the computation of basic and diluted earnings per share:

	<u>Successor</u>		<u>Predecessor</u>
	<u>For the Nine Months Ended September 30, 2019</u>	<u>For the Period April 11, 2018 to September 30, 2018</u>	<u>For the Period January 1, 2018 to April 10, 2018</u>
<b>Numerator:</b>			
Net Income	\$ 41,054	\$ 8,651	\$ 25,910
<b>Denominator:</b>			
Weighted Average Common Stock			
Outstanding - Basic	2,476	2,471	100,000
Dilutive effects of Stock Options (1)	55	—	—
Weighted Average Common Stock			
Outstanding - Diluted	2,531	2,471	100,000
Basic earnings per share	\$ 16.58	\$ 3.50	\$ 0.26
Diluted earnings per share	\$ 16.22	\$ 3.50	\$ 0.26

- (1) There were 175,568 performance-based stock options outstanding at September 30, 2019 that were excluded from the calculation of diluted EPS. There were no options outstanding for the period April 11, 2018 through September 30, 2018 or January 1, 2018 through April 10, 2018.

**SCA ACQUISITION HOLDINGS, LLC****NOTES TO CONDENSED CONSOLIDATED FINANCIAL STATEMENTS****(Dollars in thousands)****(unaudited)**

Outstanding warrants have been included in basic and dilutive weighted average shares outstanding as they are equity classified, have an exercise price of \$0.01, and all necessary conditions for issuance have been met.

**5. PROPERTY & EQUIPMENT**

The Company purchased one of its aircraft previously under an operating lease agreement in February 2019 (see Note 7 for related financing) and a spare engine in August of 2019. In addition, the Company entered into three new Finance Leases for aircraft, one each in March, April and May of 2019.

The Accumulated Depreciation on owned assets was \$17,799 and \$6,359 as of September 30, 2019 and December 31, 2018, respectively. Depreciation expense was \$12,814, \$4,090 and \$2,315 for the nine months ended September 30, 2019, the period April 11, 2018 through September 30, 2018 and the period January 1, 2018 through April 10, 2018, respectively.

The Accumulated Amortization on Finance Lease Assets was \$13,719 and \$4,476 as of September 30, 2019 and December 31, 2018, respectively. Amortization Expense was \$9,244, \$2,064 and \$119 for the nine months ended September 30, 2019, the period April 11, 2018 through September 30, 2018 and the period January 1, 2018 through April 10, 2018, respectively. Amortization on Finance Lease Assets is classified in Depreciation and Amortization on the Condensed Consolidated Statements of Operations.

**6. GOODWILL AND INTANGIBLE ASSETS**

Components of Goodwill and Intangible Assets were as follows:

	<b>September 30, 2019</b>		
	<u>Gross Carrying Amount</u>	<u>Accumulated Amortization</u>	<u>Net Carrying Value</u>
Goodwill	\$ 222,223	\$ —	\$ 222,223
Intangible Assets with Finite Lives:			
Customer Relationships	48,000	(5,890)	42,110
Intangible Assets with Indefinite Lives:			
Tradename	56,000	—	56,000
Total Intangible Assets	<u>104,000</u>	<u>(5,890)</u>	<u>98,110</u>
Total Goodwill and Intangible Assets	<u>\$ 326,223</u>	<u>\$ (5,890)</u>	<u>\$ 320,333</u>
	<b>December 31, 2018</b>		
	<u>Gross Carrying Amount</u>	<u>Accumulated Amortization</u>	<u>Net Carrying Value</u>
Goodwill	\$ 222,223	\$ —	\$ 222,223
Intangible Assets with Finite Lives:			
Customer Relationships	48,000	(2,890)	45,110
Intangible Assets with Indefinite Lives:			
Tradename	56,000	—	56,000
Total Intangible Assets	<u>104,000</u>	<u>(2,890)</u>	<u>101,110</u>
Total Goodwill and Intangible Assets	<u>\$ 326,223</u>	<u>\$ (2,890)</u>	<u>\$ 323,333</u>

**SCA ACQUISITION HOLDINGS, LLC**

**NOTES TO CONDENSED CONSOLIDATED FINANCIAL STATEMENTS**

**(Dollars in thousands)**

**(unaudited)**

---

The Company recognized \$3,000 and \$1,890 of amortization expense during the nine months ended September 30, 2019 and the period April 11, 2018 to September 30, 2018, respectively. Amortization is classified in Depreciation and Amortization on the Condensed Consolidated Statements of Operations. As of September 30, 2019, estimated annual amortization expense for each of the next five fiscal years is \$4,000 and \$22,110 thereafter.

**7. FINANCING AGREEMENTS**

**Lines of Credit** - The Company entered into a revolving credit agreement with a financial institution with funds becoming available on the Acquisition Date. This agreement provides available credit based upon defined thresholds to a maximum amount of \$20,000. Available credit under this agreement as of September 30, 2019 and December 31, 2018 was limited to \$19,650 and \$16,008, respectively, since it was reduced by outstanding letters of credit. Outstanding balances bear interest at the greatest of a) the Prime Rate or b) the Federal Funds Effective Rate plus 0.5% or c) the Adjusted London Interbank Offered Rate for an interest period of one-month plus 1.00%. SCA pays a 0.5% commitment fee on the average daily unused balance. The revolving credit agreement is secured by certain assets of SCA and contains a financial covenant and guarantees. SCA was in compliance with the covenant as of September 30, 2019 and December 31, 2018. As of September 30, 2019 and December 31, 2018, there were no outstanding balances on the revolving credit agreement. The interest rate as of September 30, 2019 and December 31, 2018 was 6.5%.

**Long Term Debt** - During 2018, SCA entered into a series of promissory note agreements with original loan amounts totaling \$59,342 to purchase aircraft and flight equipment. Each promissory note bears an interest rate of 8.45%, has a five-year term with principal and interest payments due monthly and a lump sum payment due at the end.

During the nine months ended September 30, 2019, SCA entered into a promissory note agreement with an original loan amount of \$12,750 to purchase an aircraft and flight equipment. This note bears an interest rate of 8.45%, has a five-year term with principal and interest payments due monthly and a lump sum payment due at the end. In addition, SCA entered a promissory note agreement with an original loan amount of \$600 to finance leasehold improvements associated with the Company's headquarters. This note bears an interest rate of 5.0%, has a ten-year term with principal and interest payments due monthly.

In December 2019, the Company arranged for the issuance of Class A, Class B and Class C pass-through trust certificates Series 2019-1 (the "2019-01 EETC"), in an aggregate face amount of \$248,587 (the "Certificates") for the purpose of financing or refinancing 13 used aircraft. SCA plans to use the proceeds from the 2019-01 EETC to purchase three additional aircraft, purchase seven aircraft currently under operating or financing leases with purchase options, and refinance three aircraft currently owned and financed under previously existing debt financing. The total appraised value of the 13 aircraft is approximately \$292,450. The Certificates were issued to certain institutional investors, and the 2019-1 EETC provides that the face amount of the Certificates will be funded by the purchase price paid by such investors for its Certificates and placed in escrow. As of January 9, 2020, SCA used \$68,920 of such escrowed funds to finance the purchase of four of the 13 aircraft. The Certificates bear interest at the following rates per annum: Class A, 4.13% relating to a tranche of seven of the financed aircraft and 4.25% relating to a tranche of six of the financed aircraft; Class B, 4.66% relating to a tranche of seven of the financed aircraft and 4.78% related to a tranche of six of the financed aircraft; and Class C, 6.95%. The expected maturity date of Class A is December 15, 2027, the Class B is December 15, 2025 and the Class C is December 15, 2023.

[Table of Contents](#)

## SCA ACQUISITION HOLDINGS, LLC

## NOTES TO CONDENSED CONSOLIDATED FINANCIAL STATEMENTS

(Dollars in thousands)

(unaudited)

Long-term Debt included the following:

	September 30, 2019	December 31, 2018
Note payable to Wilmington Trust Company dated October 2018, with an original loan amount of \$23,146 payable in monthly installments of \$275 through September 2023, and then a final lump sum payment of \$6,944 in October 2023. This note bears interest at an annual rate of 8.45% and is secured by the equipment for which the loan was used.	\$ 20,125	\$ 22,597
Note payable to Wilmington Trust Company dated October 2018, with an original loan amount of \$16,106 payable in monthly installments of \$191 through September 2023, and then final lump sum payment of \$4,832 in October 2023. This note bears interest at an annual rate of 8.45% and is secured by the equipment for which the loan was used.	14,004	15,723
Note payable to Wilmington Trust Company dated November 2018, with an original loan amount of \$16,419 payable in monthly installments of \$195 through October 2023, and then final lump sum payment of \$4,926 in November 2023. This note bears interest at an annual rate of 8.45% and is secured by the equipment for which the loan was used.	14,471	16,214
Note payable to Wilmington Trust Company dated February 2019, with an original loan amount of \$12,750 payable in monthly installments of \$151 through January 2024, and then final lump sum payment of \$2,825 in February 2024. This note bears interest at an annual rate of 8.45% and is secured by the equipment for which the loan was used.	11,691	—
Note payable to Wilmington Trust Company dated November 2018, with an original loan amount of \$3,671 payable in monthly installments of \$44 through October 2023, and then final lump sum payment of \$1,101 in November 2023. This note bears interest at an annual rate of 8.45% and is secured by the equipment for which the loan was used.	3,235	3,627
Note payable to Alliance Bank dated February 2019, with an original loan amount of \$600 payable in monthly installments of \$5 through March 2029. This note bears interest at an annual rate of 5.0%.	581	—
Notes payable to Riverland Bank dated between April 2015 and May 2016, with original loan amounts totaling \$734 payable in monthly installments with expirations between April 2020 and April 2021. The notes bear interest at an annual rate of 5.15% and is secured by the equipment for which the loan was used.	150	267
Total Debt	64,257	58,429
Less: Current Maturities of Long-term Debt	(10,387)	(8,606)
Total Long-term Debt	<u>\$ 53,870</u>	<u>\$ 49,823</u>

**SCA ACQUISITION HOLDINGS, LLC****NOTES TO CONDENSED CONSOLIDATED FINANCIAL STATEMENTS****(Dollars in thousands)****(unaudited)**

Future maturities of the outstanding Debt are as follows:

<b>Years Ending December 31</b>	
Remainder 2019	\$ 2,621
2020	10,421
2021	10,339
2022	10,324
2023	26,253
Thereafter	4,299
<b>Total</b>	<b><u>\$ 64,257</u></b>

**8. FUEL DERIVATIVE**

The Company's operations are inherently dependent upon the price of aircraft fuel. To manage economic risks associated with fluctuations in aircraft fuel prices, the Company periodically enters into fuel option and swap contracts. The Company does not apply hedge accounting to its fuel derivative contracts, nor does it hold or issue them for trading purposes.

Fuel derivative contracts are recognized at fair value on the Condensed Consolidated Balance Sheet as Derivative Assets, if the fair value is in an asset position, or as Derivative Liabilities, if the fair value is in a liability position. SCA's portfolio value of fuel derivative contracts were \$1,430 and \$12,006 of Derivative Liabilities as of September 30, 2019 and December 31, 2018, respectively. SCA did not have fuel derivative contracts prior to April 11, 2018. The Company did not have any collateral held by counterparties to these agreements as of September 30, 2019 and December 31, 2018.

Unrealized gain or (loss) on fuel derivatives was \$6,894 and \$1,895 for the nine months ended September 30, 2019 and the period April 11, 2018 through September 30, 2018, respectively. Fuel derivative expenses are classified in Aircraft Fuel on the Condensed Consolidated Statements of Operations.

The cash premiums paid for fuel derivative positions was \$566 and \$1,192 for the nine months ended September 30, 2019 and the period April 11, 2018 through September 30, 2018, respectively.

Fuel derivative contract settlements were \$3,116 for the nine months ended September 30, 2019. There were no fuel derivative contract settlements prior to 2019. As of September 30, 2019, the Company had outstanding fuel derivative contracts covering 48.4 million gallons of crude oil and jet fuel that will settle between October 2019 and March 2021.

**9. FAIR VALUE OF ASSETS AND LIABILITIES**

Accounting standards define fair value as the exchange price that would be received for an asset or paid to transfer a liability (an exit price) in the principal or most advantageous market for the asset or liability in an orderly transaction between market participants on the measurement date. The standards also establish a fair value hierarchy, which requires an entity to maximize the use of observable inputs and minimize the use of

## SCA ACQUISITION HOLDINGS, LLC

## NOTES TO CONDENSED CONSOLIDATED FINANCIAL STATEMENTS

(Dollars in thousands)

(unaudited)

unobservable inputs when measuring fair value. Under GAAP, there are three levels of inputs that may be used to measure fair value:

Level 1 - Quoted prices for identical assets or liabilities in active markets.

Level 2 - Observable inputs other than Level 1 prices, such as quoted prices for similar assets or liabilities in active markets; quoted prices for identical or similar assets or liabilities in markets that are not active; or other inputs that are observable or can be corroborated by observable market data for substantially the full term of the assets or liabilities.

Level 3 - Unobservable inputs that are supported by little or no market activity and that are significant to the fair value of the assets or liabilities.

The Company uses the following valuation methodologies for financial instruments measured at fair value on a recurring basis.

**Derivative Instruments** - Derivative instruments are accounted for as either assets or liabilities and are carried at fair value. The fair value for fuel derivative options and swaps is determined utilizing an option pricing model that uses inputs that are readily available in active markets or can be derived from information available in active markets and are classified within Level 2.

The following table summarizes the liabilities measured at fair value on a recurring basis:

	September 30, 2019			Total
	Level 1	Level 2	Level 3	
Liabilities				
Fuel Derivative Contracts	\$ —	\$ 1,430	\$ —	\$ 1,430
Total Liabilities measured at fair value on a recurring basis	<u>\$ —</u>	<u>\$ 1,430</u>	<u>\$ —</u>	<u>\$ 1,430</u>

	December 31, 2018			Total
	Level 1	Level 2	Level 3	
Liabilities				
Fuel Derivative Contracts	\$ —	\$ 12,006	\$ —	\$ 12,006
Total Liabilities measured at fair value on a recurring basis	<u>\$ —</u>	<u>\$ 12,006</u>	<u>\$ —</u>	<u>\$ 12,006</u>

Certain assets are measured at fair value on a nonrecurring basis. The Company's non-financial assets, which primarily consist of property and equipment, intangible assets and goodwill are not required to be measured at fair value on a recurring basis and are reported at carrying value. However, on a periodic basis whenever events or changes in circumstances indicate that their carrying may not be recoverable, non-financial assets are assessed for impairment and, if applicable, written down to fair value using significant unobservable inputs, classified as Level 3.

The Company's debt portfolio consists of fixed-rate notes payable, the majority of which were entered into during October and November 2018 and are carried at cost. Cost approximates fair value based on similar borrowing rates as of September 30, 2019.

**SCA ACQUISITION HOLDINGS, LLC**

**NOTES TO CONDENSED CONSOLIDATED FINANCIAL STATEMENTS**

**(Dollars in thousands)**

**(unaudited)**

---

**10. INCOME TAX**

As of the Acquisition date of April 11, 2018, the Company elected to be treated as a corporation for income tax purposes. Prior to the acquisition, the Company was treated as a partnership and therefore no Predecessor 2018 amounts are shown.

The Company's effective tax rate for the nine months ended September 30, 2019 was 23.3% and for the period from April 11, 2018 to September 30, 2018 it was 24.3%. The effective tax rate represents a blend of federal and state taxes and includes the impact of certain nondeductible items.

**11. EMPLOYEE BENEFIT PLANS**

The Company has a 401(k) profit-sharing retirement plan covering substantially all employees. The plan allows employee contributions up to 50% of a participant's eligible compensation, subject to limits established under the 401(k) plan and annual IRS elective deferral limits. SCA currently matches 100% of participants contribution up to a maximum of 4% for non-pilot participants' and 6% for pilot participants' eligible compensation and the plan allows for a discretionary Company contribution. The Company made cash contributions of approximately \$676, \$401 and \$308 for the nine months ended September 30, 2019, the period April 11, 2018 through September 30, 2018, and the period January 1, 2018 through April 10, 2018, respectively. The Company made discretionary contributions of approximately \$3,288, \$1,608 and \$1,026 for the nine months ended September 30, 2019, the period April 11, 2018 through September 30, 2018, and the period January 1, 2018 through April 10, 2018, respectively. Contributions are classified in Salaries, Wages, and Benefits on the Condensed Consolidated Statements of Operations.

**12. LEASES**

In 2016, the FASB issued ASC 842, which requires operating leases with a duration greater than 12 months to be recorded on the balance sheet. Under ASC 842, a lessee must recognize a right-of-use asset and a lease liability, initially measured at the present value of the lease payments over the lease term.

The Company uses the rate implicit in the lease to discount lease payments to present value, however, the leases generally do not provide a readily determinable implicit rate. Therefore, the Company estimates the incremental borrowing rate to discount lease payments based on information available initially at adoption and at lease commencement going forward, taking into consideration recent debt issuances as well as publicly available data for instruments with similar characteristics.

The Company's lease agreements do not contain any residual value guarantees. SCA reviewed its operating leases for extension options that may be reasonably certain to be exercised and then would become part of the right-of-use assets and lease liabilities. As of September 30, 2019, the Company did not have any material operating leases with extension or termination options which are reasonably certain to be exercised.

The Company adopted ASC 842 using the modified retrospective transition approach with an effective date of January 1, 2019. The Company elected the package of practical expedients, which allows the Company to carryforward the historical assessment of the following: (1) whether the Company's contracts are or contain leases, (2) lease classification, and (3) initial direct costs. The Company also elected to combine lease and non-lease components. Leases with an initial term of twelve months or less will be recognized in the Condensed Consolidated Statements of Operations on a straight-line basis over the lease term.

## SCA ACQUISITION HOLDINGS, LLC

## NOTES TO CONDENSED CONSOLIDATED FINANCIAL STATEMENTS

(Dollars in thousands)

(unaudited)

The Company classifies its Operating Leases into three categories; Aircraft, Real Estate, and Other. Aircraft leases consist of aircrafts and aircraft equipment under operating lease agreements. As of September 30, 2019, the Company had 25 leases for aircraft, of which 17 were operating leases and 8 were under finance leases, and one engine under an operating lease with an initial term of twelve months. Real Estate leases consist of leased hangar and administration facilities and Other leases consist of non-aircraft equipment under operating lease agreements. Real Estate and Other leases have initial terms of up to 10 years.

The Company also has various airport terminal agreements which include provisions for variable lease payments which are based on several factors, including, but not limited to, number of carriers, enplaned passengers, and airports' annual operating budgets. Due to the variable nature of the rates, these leases are not recorded on the Company's Condensed Consolidated Balance Sheet as a right-of-use asset and lease liability.

The following table summarizes the lease-related assets and liabilities recorded on the Company's Condensed Consolidated Balance Sheet:

	Classification	September 30, 2019	December 31, 2018
<b>Assets</b>			
Finance lease assets, net	Property and Equipment, net	\$ 156,485	\$ 92,970
Operating lease assets	Operating Lease Right-of-use Assets	155,932	—
Total lease assets		<u>\$ 312,417</u>	<u>\$ 92,970</u>
<b>Liabilities</b>			
Current:			
Finance lease liabilities	Short-term Finance Lease Obligations	11,239	6,115
Operating lease liabilities	Short-term Operating Lease Obligations	33,439	—
Long-term:			
Finance lease liabilities	Long-term Finance Lease Obligations	147,695	85,702
Operating lease liabilities	Long-term Operating Lease Obligations	148,437	—
Total lease liabilities		<u>\$ 340,810</u>	<u>\$ 91,817</u>



[Table of Contents](#)

SCA ACQUISITION HOLDINGS, LLC

NOTES TO CONDENSED CONSOLIDATED FINANCIAL STATEMENTS

(Dollars in thousands)

(unaudited)

The following table provides details of the Company's future minimum lease payments under finance and operating leases as of September 30, 2019:

	Finance Leases	Operating Leases			Total
		Aircraft	Real Estate	Other	
Remainder of 2019	\$ 5,671	\$ 10,803	\$ 895	\$ 463	\$ 17,832
2020	22,732	35,910	2,785	1,843	63,270
2021	22,732	32,842	2,592	1,675	59,841
2022	22,732	32,842	2,337	1,561	59,472
2023	22,732	32,592	1,841	659	57,824
Thereafter	128,548	42,328	9,939	—	180,815
<b>Total Minimum Lease Payments</b>	<b>225,147</b>	<b>187,317</b>	<b>20,389</b>	<b>6,201</b>	<b>439,054</b>
Less: Amount Representing Interest	(66,213)	(27,896)	(3,533)	(602)	(98,244)
Present Value of Minimum Lease Payments	158,934	159,421	16,856	5,599	340,810
Less: Short-term Obligations	(11,239)	(29,927)	(1,940)	(1,572)	(44,678)
<b>Long-term Lease Obligations</b>	<b>\$ 147,695</b>	<b>\$ 129,494</b>	<b>\$ 14,916</b>	<b>\$ 4,027</b>	<b>\$ 296,132</b>

The following table presents lease costs related to the Company's Finance and Operating Leases:

Classification	Successor		Predecessor For the Period January 1, 2018 to April 10, 2018	
	For the Nine Months Ended September 30, 2019	For the Period April 11, 2018 to September 30, 2018		
<b>Finance lease cost</b>				
Amortization of leased assets	Depreciation and Amortization	\$ 9,244	\$ 2,064	\$ 119
Interest on lease liabilities	Interest Expense	8,018	2,547	293
<b>Operating lease cost</b>				
Included in ROU asset - Aircraft	Aircraft Rent (1)	31,030	22,325	16,177
Included in ROU asset - Other	Ground Handling, Landing Fees and Airport Rent & Other Operating	4,061	2,549	1,648
Short-term	Aircraft Rent	4,656	938	6,148
Variable - Aircraft	Aircraft Rent (1)	2,273	280	6,004
Variable - Other	Landing Fees & Airport Rentals	1,075	431	440
<b>Total Lease cost</b>		<b>\$ 60,357</b>	<b>\$ 31,134</b>	<b>\$ 30,829</b>

(1) Includes credits for amortization of overmarket credits established on the acquisition date.

**SCA ACQUISITION HOLDINGS, LLC**  
**NOTES TO CONDENSED CONSOLIDATED FINANCIAL STATEMENTS**  
**(Dollars in thousands)**  
**(unaudited)**

---

The following table presents Supplemental cash flow information related to leases, included in the Condensed Consolidated Statement of Cash Flows:

	<b>For the Nine Months Ended September 30, 2019</b>
Cash paid for amounts included in the measurement of lease liabilities	
Operating Cash Flows for Operating Leases	\$ 38,296
Operating Cash Flows for Finance Leases	\$ 8,018
Financing Cash Flows for Finance Leases	\$ 6,665
Right-of-use Assets established due to additional lease obligations:	
Operating Leases	\$ 5,470

The table below presents lease-related terms and discount rates related to the Company's Finance and Operating Leases:

	<b>September 30, 2019</b>
Weighted-average remaining lease term	
Finance Leases	10 years
Operating Leases	3 years
Weighted-average discount rate	
Finance Leases	7.8%
Operating Leases	5.9%

### **13. SPECIAL ITEMS**

**Special Items, net** - The Company recognized \$6,378, \$1,757 and \$271 of expense for the nine months ended September 30, 2019, the period April 11, 2018 through September 30, 2018, and the period January 1, 2018 through April 10, 2018, respectively. Special Items recognized during 2019 related to contractual obligations for retired technology, partially offset by proceeds obtained from the sale of airport slot rights. Special Items recognized during 2018 related to early-out payments and other expenses incurred in connection with outsourcing certain operations personnel and other employee initiatives. These efforts were primarily related to airport station, flight attendants and ground handling employees.

### **14. CONTINGENCIES**

The Company is subject to various legal proceedings in the normal course of business and records legal costs as incurred. Management believes these proceedings will not have a materially adverse effect on the Company.

### **15. SUBSEQUENT EVENTS**

The Company evaluated subsequent events for the period from the Balance Sheet date through February 5, 2020, the date that the Condensed Consolidated Financial Statements were available to be issued.

**SCA ACQUISITION HOLDINGS, LLC**

**NOTES TO CONDENSED CONSOLIDATED FINANCIAL STATEMENTS**

**(Dollars in thousands)**

**(unaudited)**

---

**Amazon Agreement**

On December 13, 2019, the Company signed a six-year contract (with two, two-year extension options, for a maximum term of 10 years) with Amazon.com Services, Inc. (together with its affiliates, “Amazon”) to provide them with air cargo services. Amazon will supply the aircraft and bear directly or reimburse us for certain operating expenses, including fuel and heavy maintenance. The aircraft will fly under the Company’s air carrier operating certificate and the Company will supply the crew, maintenance and insurance for the aircraft. Amazon will pay a fixed monthly fee per aircraft as well as a set rate per block hour flown.

In connection with the agreement, the Company issued to Amazon warrants to purchase an aggregate of 502,028 shares of common stock at an exercise price of \$286.46 per share. One percent of the warrants vested upon issuance and incremental tranches will vest upon certain milestones of aggregate global payments by Amazon or its affiliates to the Company up to a total of \$1.12 billion of aggregate payments. Any unvested warrants will become vested upon a change of control or certain transfers of 30% or more of the voting power in the Company to a new person or group (other than an initial public offering or any follow-on equity offering by the Company or SCA Horus Holdings, LLC, an affiliate of certain investment funds managed by Apollo, pursuant to an effective registration statement, so long as no person or group acquires more than 50% of the voting power of the Company in such offering). To the extent any Amazon warrants were not previously exercised, and if the fair market value of the Company’s common stock is greater than the warrant exercise price, the unexercised warrants will be automatically net exercised immediately before their expiration. As is the case for investment in the Company, the exercise of the warrants is limited by restrictions imposed by federal law on foreign ownership and control of U.S. airlines.

Flying under the agreement is expected to begin in the second quarter of 2020.

**Reorganization Transactions**

On January 31, 2020, all the outstanding Apollo Warrants were exercised to purchase common stock of SCA Acquisition Holdings, LLC. On January 31, 2020, SCA Acquisition Holdings, LLC was converted into a Delaware corporation pursuant to a statutory conversion and changed its name to Sun Country Airlines Holdings, Inc. In connection with the conversion to a corporation, all of the outstanding shares of SCA Acquisition Holdings, LLC common stock were converted into shares of Sun Country Airlines Holdings, Inc. common stock, the outstanding warrants held by Amazon to purchase shares of SCA Acquisition Holdings, LLC common stock were converted into warrants to purchase shares of Sun Country Airlines Holdings, Inc. common stock and all of the outstanding options to purchase shares of SCA Acquisition Holdings, LLC common stock were converted into options to purchase shares of Sun Country Airlines Holdings, Inc. common stock.

\*\*\*\*\*

**Shares**



**Sun Country Airlines Holdings, Inc.**

**Common Stock**

---

**PROSPECTUS**

---

**Barclays**

---

---

**PART II**

**INFORMATION NOT REQUIRED IN PROSPECTUS**

**Item 13. Other Expenses of Issuance and Distribution**

Set forth below is a table of the registration fee for the Securities and Exchange Commission (the “SEC”) and estimates of all other expenses to be paid by the registrant in connection with the issuance and distribution of the securities described in the registration statement:

SEC registration fee	\$
Stock exchange listing fee	
Financial Industry Regulatory Authority filing fee	
Printing expenses	
Legal fees and expenses	
Accounting fees and expenses	
Blue Sky fees and expenses	
Transfer agent and registrar fees	
Miscellaneous	
Total	\$

**Item 14. Indemnification of Directors and Officers**

Section 145 of the Delaware General Corporation Law (the “DGCL”) provides that a corporation may indemnify directors and officers as well as other employees and individuals against expenses (including attorneys’ fees), judgments, fines, and amounts paid in settlement actually and reasonably incurred by such person in connection with any threatened, pending, or completed actions, suits, or proceedings in which such person is made a party by reason of such person being or having been a director, officer, employee or agent to the registrant. The DGCL provides that Section 145 is not exclusive of other rights to which those seeking indemnification may be entitled under any bylaw, agreement, vote of stockholders, or disinterested directors or otherwise. The registrant’s bylaws provide for indemnification by the registrant of its directors, officers, and employees to the fullest extent permitted by the DGCL.

Section 102(b)(7) of the DGCL permits a corporation to provide in its certificate of incorporation that a director of the corporation shall not be personally liable to the corporation or its stockholders for monetary damages for breach of fiduciary duty as a director, except for liability (i) for any breach of the director’s duty of loyalty to the corporation or its stockholders, (ii) for acts or omissions not in good faith or which involve intentional misconduct or a knowing violation of law, (iii) for unlawful payments of dividends or unlawful stock repurchases, redemptions, or other distributions, or (iv) for any transaction from which the director derived an improper personal benefit. The registrant’s certificate of incorporation provides for such limitation of liability.

The registrant maintains standard policies of insurance under which coverage is provided (a) to its directors and officers against loss rising from claims made by reason of breach of duty or other wrongful act and (b) to the registrant with respect to payments which may be made by the registrant to such officers and directors pursuant to the above indemnification provision or otherwise as a matter of law.

The proposed form of underwriting agreement we enter into in connection with the sale of common stock being registered will provide for indemnification of directors and officers of the registrant by the underwriters against certain liabilities.

We expect to enter into customary indemnification agreements with our executive officers and directors that provide them, in general, with customary indemnification in connection with their service to us or on our behalf.

### **Item 15. Recent Sales of Unregistered Securities**

Set forth below is information regarding securities sold or granted by us within the past three years that were not registered under the Securities Act of 1933, as amended (the “Securities Act”). Also included is the consideration, if any, received by us for such securities and information relating to the section of the Securities Act, or rule of the SEC, under which exemption from registration was claimed for such sales and grants. Such information is rounded to the nearest whole number.

On April 11, 2018, SCA Acquisition Holdings, LLC issued 282,009 equity interests, which are denominated as shares of common stock (“SCA common stock”), to AP VIII (SCA Stock AIV), LLC, and warrants to purchase 2,117,991 shares of SCA common stock to AP VIII (SCA Warrant AIV), LLC.

On April 20, 2018, SCA Acquisition Holdings, LLC issued 65,000 shares of SCA common stock to an employee at a purchase price of \$100 per share.

On April 20, 2018, SCA Acquisition Holdings, LLC issued 10,000 shares of SCA common stock to an employee at a purchase price of \$100 per share.

On November 21, 2018, SCA Acquisition Holdings, LLC issued an aggregate of 316,628 options to purchase shares of SCA common stock to certain employees.

On February 6, 2019, SCA Acquisition Holdings, LLC issued an aggregate of 1,707 options to purchase shares of SCA common stock to certain employees.

On April 17, 2019, SCA Acquisition Holdings, LLC issued an aggregate of 1,956 options to purchase shares of SCA common stock to certain employees.

On May 20, 2019, SCA Acquisition Holdings, LLC issued an aggregate of 14,224 options to purchase shares of SCA common stock to certain employees.

On June 3, 2019, SCA Acquisition Holdings, LLC issued an aggregate of 28,448 options to purchase shares of SCA common stock to certain employees.

On July 31, 2019, SCA Acquisition Holdings, LLC issued an aggregate of 426 options to purchase shares of SCA common stock to certain employees.

On August 1, 2019, SCA Acquisition Holdings, LLC issued 3,000 shares of SCA common stock to an employee.

On November 19, 2019, SCA Acquisition Holdings, LLC issued 7,112 options to purchase shares of SCA common stock to an employee.

On December 13, 2019, SCA Acquisition Holdings, LLC issued warrants to purchase 502,028 shares of SCA common stock to Amazon.com NV Investment Holdings LLC.

On January 31, 2020, SCA Acquisition Holdings, LLC issued 2,117,991 shares of SCA common stock to SCA Horus Holdings, LLC upon the exercise of the warrant to purchase 2,117,991 shares at an exercise price of \$0.01 per share.

On January 31, 2020, upon the conversion of SCA Acquisition Holdings, LLC to Sun Country Airlines Holdings, Inc., all of the outstanding shares of SCA common stock were converted into 2,478,000 shares of common stock of Sun Country Airlines Holdings, Inc., all outstanding options to purchase shares of SCA common stock were converted into options to purchase shares of common stock and all outstanding warrants to purchase common stock were converted into warrants to purchase shares of common stock.

Except as otherwise noted above, these transactions were exempt from registration pursuant to Section 4(a)(2) of the Securities Act, as they were transactions by an issuer that did not involve a public offering of securities.

In connection with the stock split as part of the Reorganization Transactions, Sun Country Airlines Holdings, Inc. will issue \_\_\_\_\_ shares of common stock.

## [Table of Contents](#)

### Item 16. Exhibits and Financial Statement Schedules

#### (a) Exhibits

<u>Exhibit Number</u>	<u>Exhibit Description</u>
1.1*	Form of Underwriting Agreement
2.1	Membership Interest Purchase Agreement, dated December 13, 2017, by and among Minnesota Aviation, LLC, SCA Acquisition Holdings, LLC and SCA Acquisition, LLC
2.2	Certificate of Conversion
3.1*	Form of Amended and Restated Certificate of Incorporation of Sun Country Airlines Holdings, Inc., to become effective immediately prior to the completion of this offering
3.2*	Form of Amended and Restated Bylaws of Sun Country Airlines Holdings, Inc., to become effective immediately prior to the completion of this offering
4.1*	Specimen of Share Certificate of Sun Country Airlines Holdings, Inc.
4.2#	Warrant, dated as of December 13, 2019, issued by SCA Acquisition Holdings, LLC to Amazon.com NV Investment Holdings LLC
4.3	Pass Through Trust Agreement, dated as of December 9, 2019, between Sun Country, Inc. and Wilmington Trust, National Association, as trustee
4.4	Form of Pass Through Trust Certificate, Series 2019-1A
4.5	Form of Pass Through Trust Certificate, Series 2019-1B
4.6	Form of Pass Through Trust Certificate, Series 2019-1C
4.7	Intercreditor Agreement, dated as of December 9, 2019, among Wilmington Trust, National Association, as trustee of the Sun Country Pass Through Trusts, Series 2019-1, and as subordination agent
5.1*	Opinion of Paul, Weiss, Rifkind, Wharton & Garrison LLP as to the validity of the securities being offered
10.1	Asset-based Revolving Credit Agreement, dated December 13, 2017, by and among SCA Acquisition, LLC, MN Airlines, LLC, the lenders party thereto and Barclays Bank PLC
10.2	Amendment No 1. to the Asset-based Revolving Credit Agreement, dated January 7, 2019, by and among SCA Acquisition, LLC, MN Airlines, LLC, the lenders party thereto and Barclays Bank PLC
10.3	Amended and Restated Airline Operating Agreement and Terminal Building Lease, Minneapolis-St. Paul International Airport, between Metropolitan Airports Commission and MN Airlines, LLC d/b/a Sun Country Airlines, effective January 1, 2019
10.4#	Air Transportation Services Agreement, dated as of December 13, 2019, by and between Sun Country, Inc. and Amazon.com Services, Inc.
10.5	Headquarters Facility Lease Agreement, dated as of February 19, 2019, by and between the Metropolitan Airports Commission and MN Airlines, LLC dba Sun Country Airlines
10.6	Amended and Restated Co-Brand Marketing Agreement, dated as of October 17, 2018, between First National Bank of Omaha and MN Airlines, LLC dba Sun Country Airlines.
10.7	Amendment No. 1 to Amended and Restated Co-Brand Marketing Agreement, dated as of November 1, 2018, by and between First National Bank of Omaha and MN Airlines, LLC dba Sun Country Airlines.

## Table of Contents

<u>Exhibit Number</u>	<u>Exhibit Description</u>
10.8	Inventory Support and Services Agreement, dated as of October 27, 2003, by and between Delta Air Lines, Inc. and MN Airlines, LLC.
10.9	Amendment No. 1 to the Inventory Support and Services Agreement, dated as of November 8, 2004, by and between Delta Air Lines, Inc. and MN Airlines, LLC.
10.10	Amendment No. 2 to the Inventory Support and Services Agreement, dated as of March 18, 2005, by and between Delta Air Lines, Inc. and MN Airlines, LLC.
10.11	Amendment No. 3 to the Inventory Support and Services Agreement, dated as of July 15, 2007, by and between Delta Air Lines, Inc. and MN Airlines, LLC.
10.12	Amendment No. 4 to the Inventory Support and Services Agreement, dated as of May 23, 2008, by and between Delta Air Lines, Inc. and MN Airlines, LLC.
10.13	Amendment No. 5 to the Inventory Support and Services Agreement, dated as of June 4, 2008, by and between Delta Air Lines, Inc. and MN Airlines, LLC.
10.14	Amendment No. 6 to the Inventory Support and Services Agreement, dated as of April 1, 2009, by and between Delta Air Lines, Inc. and MN Airlines, LLC.
10.15	Amendment No. 7 to the Inventory Support and Services Agreement, dated as of April 7, 2009, by and between Delta Air Lines, Inc. and MN Airlines, LLC.
10.16	Amendment No. 8 to the Inventory Support and Services Agreement, dated as of May 1, 2009, by and between Delta Air Lines, Inc. and MN Airlines, LLC.
10.17	Amendment No. 9 to the Inventory Support and Services Agreement, dated as of August 1, 2009, by and between Delta Air Lines, Inc. and MN Airlines, LLC.
10.18	Amendment No. 10 to the Inventory Support and Services Agreement, dated as of January 1, 2010, by and between Delta Air Lines, Inc. and MN Airlines, LLC.
10.19	Amendment No. 11 to the Inventory Support and Services Agreement, dated as of May 1, 2010, by and between Delta Air Lines, Inc. and MN Airlines, LLC.
10.20	Amendment No. 13 to the Inventory Support and Services Agreement, dated as of November 1, 2011, by and between Delta Air Lines, Inc. and MN Airlines, LLC.
10.21	Amendment No. 14 to the Inventory Support and Services Agreement, dated as of May 28, 2013, by and between Delta Air Lines, Inc. and MN Airlines, LLC.
10.22	Amendment No. 15 to the Inventory Support and Services Agreement, dated as of July 23, 2014, by and between Delta Air Lines, Inc. and MN Airlines, LLC.
10.23	Amendment No. 16 to the Inventory Support and Services Agreement, dated as of March 20, 2015, by and between Delta Air Lines, Inc. and MN Airlines, LLC.
10.24	Amendment No. 17 to the Inventory Support and Services Agreement, dated as of April 1, 2018, by and between Delta Air Lines, Inc. and MN Airlines, LLC.
10.25	Amendment No. 18 to the Inventory Support and Services Agreement, dated as of May 15, 2019, by and between Delta Air Lines, Inc. and MN Airlines, LLC.
10.26	2002 Master Agreement, dated as of May 1, 2019 between J. Aron & Company LLC and MN Airlines, LLC
10.27	2002 Master Agreement, dated as of April 12, 2018 between Morgan Stanley Capital Services LLC and MN Airlines, LLC
10.28	Trust Agreement of SCA-1 Intermediate Aircraft Holding Trust, dated as of September 25, 2018, by and among SCA-1 Intermediate Charitable Trust and Wilmington Trust Company



## Table of Contents

<u>Exhibit Number</u>	<u>Exhibit Description</u>
10.29*	Form of Third Amended and Restated Stockholders' Agreement by and among Sun Country Airlines Holdings, Inc. and the stockholders party thereto
10.30*	Form of Registration Rights Agreement by and between Sun Country Airlines Holdings, Inc. and the Holders party thereto
10.31*	Form of Registration Rights Agreement by and between Sun Country Airlines Holdings, Inc. and Amazon.com NV Investment Holdings LLC
10.32*†	Form of Indemnification Agreement by and between the Registrant and each of its directors and executive officers
10.33†	SCA Acquisition Holdings, LLC Amended and Restated Equity Incentive Plan, dated as of July 1, 2019
10.34*†	Form of Sun Country Airlines Holdings, Inc. 2020 Omnibus Incentive Plan
10.35*†	Form of Option Award Agreement
10.36†	Second Amended and Restated Employment Agreement, dated as of November 7, 2018, by and between Jude Bricker and SCA Acquisition Holdings, LLC
10.37†	Employment Agreement, dated as of April 17, 2019, by and between David Davis and MN Airlines, LLC.
10.38†	Employment Agreement, dated as of July 1, 2019, by and between Gregory A. Mays and Sun Country, Inc.
10.39*†	Amendment to Employment Agreement, dated as of _____, 2020, by and between David Davis and Sun Country, Inc.
21.1	Subsidiaries of the registrant
23.1*	Consent of KPMG LLP, independent registered public accounting firm
23.2*	Consent of Paul, Weiss, Rifkind, Wharton & Garrison LLP (included in Exhibit 5.1)
24.1*	Powers of Attorney (included in signature page)

\* To be filed by amendment.

† Indicates management contract or compensatory plan.

# Portions of this exhibit have been omitted pursuant to Item 601(b)(10)(iv) of Regulation S-K.

### ***(b) Financial Statement Schedule***

See the Index to the consolidated financial statements included on page F-1 for a list of the financial statements included in this registration statement. All schedules not identified above have been omitted because they are not required, are inapplicable, or the information is included in the consolidated financial statements or notes contained in this registration statement.

### **Item 17. Undertakings**

The undersigned registrant hereby undertakes to provide to the underwriters at the closing specified in the underwriting agreement, certificates in such denominations and registered in such names as required by the underwriters to permit prompt delivery to each purchaser.

Insofar as indemnification for liabilities arising under the Securities Act may be permitted to directors, officers and controlling persons of the registrant pursuant to the foregoing provisions, or otherwise, the registrant has been advised that in the opinion of the Securities and Exchange Commission such indemnification is against

## Table of Contents

public policy as expressed in the Securities Act and is, therefore, unenforceable. In the event that a claim for indemnification against such liabilities (other than the payment by the registrant of expenses incurred or paid by a director, officer or controlling person of the registrant in the successful defense of any action, suit or proceeding) is asserted by such director, officer or controlling person in connection with the securities being registered, the registrant will, unless in the opinion of its counsel the matter has been settled by controlling precedent, submit to a court of appropriate jurisdiction the question whether such indemnification by it is against public policy as expressed in the Securities Act and will be governed by the final adjudication of such issue.

The undersigned registrant hereby undertakes that:

- (1) For purposes of determining any liability under the Securities Act, the information omitted from the form of prospectus filed as part of this registration statement in reliance upon Rule 430A and contained in a form of prospectus filed by the registrant pursuant to Rule 424(b)(1) or (4) or 497(h) under the Securities Act shall be deemed to be part of this registration statement as of the time it was declared effective.
- (2) For purposes of determining any liability under the Securities Act, each post-effective amendment that contains a form of prospectus shall be deemed to be a new registration statement relating to the securities offered therein, and the offering of such securities at that time shall be deemed to be the initial bona fide offering thereof.

**EXHIBIT INDEX**

<b>Exhibit Number</b>	<b>Exhibit Description</b>
1.1*	Form of Underwriting Agreement
2.1	Membership Interest Purchase Agreement, dated December 13, 2017, by and among Minnesota Aviation, LLC, SCA Acquisition Holdings, LLC and SCA Acquisition, LLC
2.2	Certificate of Conversion
3.1*	Form of Amended and Restated Certificate of Incorporation of Sun Country Airlines Holdings, Inc., to become effective immediately prior to the completion of this offering
3.2*	Form of Amended and Restated Bylaws of Sun Country Airlines Holdings, Inc., to become effective immediately prior to the completion of this offering
4.1*	Specimen of Share Certificate of Sun Country Airlines Holdings, Inc.
4.2#	Warrant, dated as of December 13, 2019, issued by SCA Acquisition Holdings, LLC to Amazon.com NV Investment Holdings LLC
4.3	Pass Through Trust Agreement, dated as of December 9, 2019, between Sun Country, Inc. and Wilmington Trust, National Association, as trustee
4.4	Form of Pass Through Trust Certificate, Series 2019-1A
4.5	Form of Pass Through Trust Certificate, Series 2019-1B
4.6	Form of Pass Through Trust Certificate, Series 2019-1C
4.7	Intercreditor Agreement, dated as of December 9, 2019, among Wilmington Trust, National Association, as trustee of the Sun Country Pass Through Trusts, Series 2019-1, and as subordination agent
5.1*	Opinion of Paul, Weiss, Rifkind, Wharton & Garrison LLP as to the validity of the securities being offered
10.1	Asset-based Revolving Credit Agreement, dated December 13, 2017, by and among SCA Acquisition, LLC, MN Airlines, LLC, the lenders party thereto and Barclays Bank PLC
10.2	Amendment No 1. to the Asset-based Revolving Credit Agreement, dated January 7, 2019, by and among SCA Acquisition, LLC, MN Airlines, LLC, the lenders party thereto and Barclays Bank PLC
10.3	Amended and Restated Airline Operating Agreement and Terminal Building Lease, Minneapolis-St. Paul International Airport, between Metropolitan Airports Commission and MN Airlines, LLC d/b/a Sun Country Airlines, effective January 1, 2019
10.4#	Air Transportation Services Agreement, dated as of December 13, 2019, by and between Sun Country, Inc. and Amazon.com Services, Inc.
10.5	Headquarters Facility Lease Agreement, dated as of February 19, 2019, by and between the Metropolitan Airports Commission and MN Airlines, LLC dba Sun Country Airlines
10.6	Amended and Restated Co-Brand Marketing Agreement, dated as of October 17, 2018, between First National Bank of Omaha and MN Airlines, LLC dba Sun Country Airlines.
10.7	Amendment No. 1 to Amended and Restated Co-Brand Marketing Agreement, dated as of November 1, 2018, by and between First National Bank of Omaha and MN Airlines, LLC dba Sun Country Airlines.
10.8	Inventory Support and Services Agreement, dated as of October 27, 2003, by and between Delta Air Lines, Inc. and MN Airlines, LLC.

## Table of Contents

<u>Exhibit Number</u>	<u>Exhibit Description</u>
10.9	Amendment No. 1 to the Inventory Support and Services Agreement, dated as of November 8, 2004, by and between Delta Air Lines, Inc. and MN Airlines, LLC.
10.10	Amendment No. 2 to the Inventory Support and Services Agreement, dated as of March 18, 2005, by and between Delta Air Lines, Inc. and MN Airlines, LLC.
10.11	Amendment No. 3 to the Inventory Support and Services Agreement, dated as of July 15, 2007, by and between Delta Air Lines, Inc. and MN Airlines, LLC.
10.12	Amendment No. 4 to the Inventory Support and Services Agreement, dated as of May 23, 2008, by and between Delta Air Lines, Inc. and MN Airlines, LLC.
10.13	Amendment No. 5 to the Inventory Support and Services Agreement, dated as of June 4, 2008, by and between Delta Air Lines, Inc. and MN Airlines, LLC.
10.14	Amendment No. 6 to the Inventory Support and Services Agreement, dated as of April 1, 2009, by and between Delta Air Lines, Inc. and MN Airlines, LLC.
10.15	Amendment No. 7 to the Inventory Support and Services Agreement, dated as of April 7, 2009, by and between Delta Air Lines, Inc. and MN Airlines, LLC.
10.16	Amendment No. 8 to the Inventory Support and Services Agreement, dated as of May 1, 2009, by and between Delta Air Lines, Inc. and MN Airlines, LLC.
10.17	Amendment No. 9 to the Inventory Support and Services Agreement, dated as of August 1, 2009, by and between Delta Air Lines, Inc. and MN Airlines, LLC.
10.18	Amendment No. 10 to the Inventory Support and Services Agreement, dated as of January 1, 2010, by and between Delta Air Lines, Inc. and MN Airlines, LLC.
10.19	Amendment No. 11 to the Inventory Support and Services Agreement, dated as of May 1, 2010, by and between Delta Air Lines, Inc. and MN Airlines, LLC.
10.20	Amendment No. 13 to the Inventory Support and Services Agreement, dated as of November 1, 2011, by and between Delta Air Lines, Inc. and MN Airlines, LLC.
10.21	Amendment No. 14 to the Inventory Support and Services Agreement, dated as of May 28, 2013, by and between Delta Air Lines, Inc. and MN Airlines, LLC.
10.22	Amendment No. 15 to the Inventory Support and Services Agreement, dated as of July 23, 2014, by and between Delta Air Lines, Inc. and MN Airlines, LLC.
10.23	Amendment No. 16 to the Inventory Support and Services Agreement, dated as of March 20, 2015, by and between Delta Air Lines, Inc. and MN Airlines, LLC.
10.24	Amendment No. 17 to the Inventory Support and Services Agreement, dated as of April 1, 2018, by and between Delta Air Lines, Inc. and MN Airlines, LLC.
10.25	Amendment No. 18 to the Inventory Support and Services Agreement, dated as of May 15, 2019, by and between Delta Air Lines, Inc. and MN Airlines, LLC.
10.26	2002 Master Agreement, dated as of May 1, 2019 between J. Aron & Company LLC and MN Airlines, LLC
10.27	2002 Master Agreement, dated as of April 12, 2018 between Morgan Stanley Capital Services LLC and MN Airlines, LLC
10.28	Trust Agreement of SCA-1 Intermediate Aircraft Holding Trust, dated as of September 25, 2018, by and among SCA-1 Intermediate Charitable Trust and Wilmington Trust Company
10.29*	Form of Third Amended and Restated Stockholders' Agreement by and among Sun Country Airlines Holdings, Inc. and the stockholders party thereto

## Table of Contents

<u>Exhibit Number</u>	<u>Exhibit Description</u>
10.30*	Form of Registration Rights Agreement by and between Sun Country Airlines Holdings, Inc. and the Holders party thereto
10.31*	Form of Registration Rights Agreement by and between Sun Country Airlines Holdings, Inc. and Amazon.com NV Investment Holdings LLC
10.32*†	Form of Indemnification Agreement by and between the Registrant and each of its directors and executive officers
10.33†	SCA Acquisition Holdings, LLC Amended and Restated Equity Incentive Plan, dated as of July 1, 2019
10.34*†	Form of Sun Country Airlines Holdings, Inc. 2020 Omnibus Incentive Plan
10.35*†	Form of Option Award Agreement
10.36†	Second Amended and Restated Employment Agreement, dated as of November 7, 2018, by and between Jude Bricker and SCA Acquisition Holdings, LLC
10.37†	Employment Agreement, dated as of April 17, 2019, by and between David Davis and MN Airlines, LLC.
10.38†	Employment Agreement, dated as of July 1, 2019, by and between Gregory A. Mays and Sun Country, Inc.
10.39*†	Amendment to Employment Agreement, dated as of _____, 2020, by and between David Davis and Sun Country, Inc.
21.1	Subsidiaries of the registrant
23.1*	Consent of KPMG LLP, independent registered public accounting firm
23.2*	Consent of Paul, Weiss, Rifkind, Wharton & Garrison LLP (included in Exhibit 5.1)
24.1*	Powers of Attorney (included in signature page)

\* To be filed by amendment.

† Indicates management contract or compensatory plan.

# Portions of this exhibit have been omitted pursuant to Item 601(b)(10)(iv) of Regulation S-K.

**SIGNATURES**

Pursuant to the requirements of the Securities Act of 1933, the registrant has duly caused this Registration Statement to be signed on its behalf by the undersigned, thereunto duly authorized, in Minneapolis, Minnesota, on the      day of      , 2020.

**Sun Country Airlines Holdings, Inc.**

By: \_\_\_\_\_

Name:

Title:

**POWER OF ATTORNEY**

KNOW ALL PERSONS BY THESE PRESENTS, that each individual whose signature appears below hereby constitutes and appoints Eric Levenhagen and Dave Davis, his or her true and lawful agent, proxy and attorney-in-fact, with full power of substitution and resubstitution, for him or her and in his or her name, place and stead, in any and all capacities, to (i) act on, sign and file with the Securities and Exchange Commission any and all amendments (including post-effective amendments) to this registration statement together with all schedules and exhibits thereto and any subsequent registration statement filed pursuant to Rule 462(b) under the Securities Act of 1933, as amended, together with all schedules and exhibits thereto, (ii) act on, sign and file such certificates, instruments, agreements and other documents as may be necessary or appropriate in connection therewith, (iii) act on and file any supplement to any prospectus included in this registration statement or any such amendment or any subsequent registration statement filed pursuant to Rule 462(b) under the Securities Act of 1933, as amended, and (iv) take any and all actions which may be necessary or appropriate in connection therewith, granting unto such agents, proxies and attorneys-in-fact, and each of them, full power and authority to do and perform each and every act and thing necessary or appropriate to be done, as fully for all intents and purposes as he or she might or could do in person, hereby approving, ratifying and confirming all that such agents, proxies and attorneys-in-fact or any of their substitutes may lawfully do or cause to be done by virtue thereof.

Pursuant to the requirements of the Securities Act of 1933, this Registration Statement has been signed by the following persons in the capacities and on the dates indicated.

<u>Signature</u>	<u>Title</u>	<u>Date</u>
<u>Jude Bricker</u>	Chief Executive Officer; Director (Principal Executive Officer)	, 2020
<u>Dave Davis</u>	President and Chief Financial Officer; Director (Principal Financial and Accounting Officer)	, 2020
<u>Marc Becker</u>	Director	, 2020
<u>Joshua Black</u>	Director	, 2020
<u>Antoine Munfakh</u>	Director	, 2020
<u>David Siegel</u>	Director	, 2020
<u>Juan Carlos Zuazua</u>	Director	, 2020

MEMBERSHIP INTEREST PURCHASE AGREEMENT

by and among

MINNESOTA AVIATION, LLC,

SCA ACQUISITION HOLDINGS, LLC

and

SCA ACQUISITION, LLC

December 13, 2017



**TABLE OF CONTENTS**

	<b><u>Page</u></b>
ARTICLE I PURCHASE OF UNITS; CLOSING	1
1.1 Definitions	1
1.2 Purchase and Sale of Units	1
1.3 Purchase Price; Payments at Closing	1
1.4 Purchase Price Adjustment	2
1.5 Seller's Deliveries	5
1.6 Buyer's Deliveries	6
1.7 Closing	7
1.8 Tax Treatment	7
1.9 Allocation	7
ARTICLE II REPRESENTATIONS AND WARRANTIES OF SELLER	7
2.1 Organization and Authority of Seller	8
2.2 Organization, Authority and Qualification of the Company	8
2.3 Capitalization	9
2.4 No Conflict	10
2.5 Required Filings and Consents	10
2.6 Permits; Compliance With Law	11
2.7 Financial Statements	12
2.8 No Undisclosed Liabilities	12
2.9 Absence of Certain Changes or Events	13
2.10 Employee Benefit Plans	13
2.11 Labor and Other Employment Matters	15
2.12 Contracts	16
2.13 Litigation	19
2.14 Environmental Matters	19
2.15 Intellectual Property	20
2.16 Tax Matters	21
2.17 Insurance	23
2.18 Properties and Assets	24
2.19 Real Property	24

	<u>Page</u>
2.20 Affiliate Transactions	25
2.21 Brokers	25
2.22 Aircraft	25
2.23 Company Slots and Operating Rights	26
2.24 Airports	26
2.25 U.S. Citizen; Air Carrier	26
2.26 Charter Customers	27
2.27 Assets and Sales Outside of the United States	27
2.28 Limitation on Representations or Warranties	27
ARTICLE III REPRESENTATIONS AND WARRANTIES OF BUYER	27
3.1 Organization and Authority	27
3.2 No Conflict	28
3.3 Required Filings and Consents	28
3.4 Litigation	29
3.5 Financial Capability	29
3.6 Management Arrangements	29
3.7 Citizen; Air Carrier	29
3.8 Labor Agreements	29
3.9 Brokers	29
3.10 No Other Representations or Warranties	29
ARTICLE IV COVENANTS	30
4.1 Covenants of Seller	30
4.2 No Shop	33
4.3 Notification of Certain Matters	34
4.4 Filings and Authorizations; Consummations	35
4.5 Access to Information; Confidential Information	36
4.6 Taxes	37
4.7 Tax Contests	39
4.8 Public Disclosure	40
4.9 Indemnification of Directors and Officers	40
4.10 Additional Covenants of Buyer Parties	41
4.11 Financing Cooperation	41
4.12 Payoff Letters	43

	<u>Page</u>
4.13 Termination of Affiliate Agreements	43
4.14 Resignations	43
4.15 Books and Records	44
4.16 Preparation of Closing Deliverables	44
4.17 Name Change	44
4.18 Post-Closing Available Funds of Seller	44
ARTICLE V CONDITIONS TO PURCHASE	44
5.1 Conditions to Each Party's Obligation to Effect the Transaction	44
5.2 Conditions to the Obligations of Buyer	45
5.3 Conditions to the Obligations of Seller	46
ARTICLE VI TERMINATION AND AMENDMENT	46
6.1 Termination	46
6.2 Notice of Termination	47
6.3 Effect of Termination	47
ARTICLE VII MISCELLANEOUS PROVISIONS	47
7.1 Non-Survival of Representations and Warranties	47
7.2 Notices	47
7.3 Entire Agreement	49
7.4 No Third Party Beneficiaries	49
7.5 Assignment	49
7.6 Severability	49
7.7 Counterparts and Signature	49
7.8 Interpretation	49
7.9 Governing Law	50
7.10 Submission to Jurisdiction; Waiver of Jury Trial	50
7.11 Further Assurances	51
7.12 Disclosure Schedule	51
7.13 Expenses	51
7.14 Specific Performance	51
ARTICLE VIII DEFINITIONS	51

---

APPENDIX A: Accounting Principles; Net Working Capital Calculation and Target Working Capital Amount

APPENDIX B: Company Growth Plan

APPENDIX C: Form of IP License Side Letter

APPENDIX D: Terms of Affiliate Lease Amendments

## MEMBERSHIP INTEREST PURCHASE AGREEMENT

This MEMBERSHIP INTEREST PURCHASE AGREEMENT, dated as of December 13, 2017 (this "Agreement"), is by and among Minnesota Aviation, LLC, a Minnesota limited liability company, ("Seller"), SCA Acquisition Holdings, LLC, a Delaware limited liability company ("Parent") and SCA Acquisition, LLC, a Delaware limited liability company and a wholly-owned indirect subsidiary of Parent ("Buyer", and together with Parent, "Buyer Parties").

### RECITALS:

WHEREAS, Seller is the owner of all of the units of the limited liability company interests (collectively, the "Units") of MN Airlines, LLC, a Minnesota limited liability company, d/b/a Sun Country Airlines (the "Company"); and

WHEREAS, Buyer desires to purchase from Seller, and Seller desires to sell to Buyer, all the Units in the manner and subject to the terms and conditions set forth in this Agreement.

NOW, THEREFORE, in consideration of the mutual covenants and agreements set forth herein and for other good and valuable consideration, the receipt and sufficiency of which are hereby acknowledged, Buyer and Seller agree as follows:

### ARTICLE I

#### PURCHASE OF UNITS; CLOSING

1.1 Definitions. Capitalized terms used herein but not immediately defined herein, have the meanings ascribed to them in Article VIII.

1.2 Purchase and Sale of Units. At the Closing, and upon the terms and subject to the conditions herein set forth, (a) Seller shall sell, assign, transfer, convey and deliver to Buyer, and Buyer shall acquire from Seller, all right, title and interest of Seller in and to the Units, and (b) Buyer shall pay and deliver the Purchase Price (as defined in Section 1.3(a)) below) to or on behalf of Seller and take such other actions required by this Article I.

1.3 Purchase Price; Payments at Closing.

(a) Purchase Price. Subject to the adjustments described in Section 1.4 below, the aggregate consideration for the transfer of the Units (the "Purchase Price") shall be an amount equal to:

(i) Two-hundred fifty-five million Dollars (\$255,000,000);

(ii) plus the amount, if any, by which the Closing Cash exceeds the Target Cash Amount, or minus the amount, if any, by which the Target Cash Amount exceeds the Closing Cash;

(iii) plus the amount, if any, by which the Net Working Capital Amount exceeds the Target Working Capital Amount, or minus the amount, if any, by which the Target Working Capital Amount exceeds the Net Working Capital Amount;

(iv) plus the amount, if any, by which the Target Debt Amount exceeds the amount of Company Debt, or minus the amount, if any, by which Company Debt exceeds the Target Debt Amount; and

(v) minus the amount of Unpaid Transaction Expenses.

(b) Closing Payments. Subject to the terms and conditions of this Agreement, at the Closing, Buyer shall:

(i) pay, or cause to be paid, an amount equal to the Estimated Purchase Price (as calculated based upon the Estimated Closing Statement) minus the Adjustment Escrow Amount to Seller by wire transfer of immediately available funds to an account designated by Seller no later than two (2) Business Days prior to the Closing Date;

(ii) pay, or cause to be paid, on behalf of the Company (or its designees) (A) to each Payoff Lender the Funded Debt, if any, in the amounts set forth in the applicable Payoff Letters and (B) the Unpaid Transaction Expenses to the Persons and in the amounts as specified in the Estimated Closing Statement (and the Company shall have delivered or caused to be delivered to Buyer at least three (3) Business Days prior to the Closing final invoices, wire instructions and all other information necessary for payment with respect to all Unpaid Transaction Expenses), by wire transfer of immediately available funds; and

(iii) deposit, or cause to be deposited, an amount equal to the Adjustment Escrow Amount to U.S. Bank, National Association (the "Escrow Agent") to be held in escrow pursuant to the terms of this Agreement and the Escrow Agreement, which Adjustment Escrow Amount, together with earnings thereon, as reduced by any losses thereon and disbursements therefrom, being referred to herein as the "Adjustment Escrow Fund".

(c) Withholding. Buyer and the Company shall be entitled to deduct and withhold from any amount otherwise payable pursuant to this Agreement such amounts as may be required to be deducted and withheld with respect to the making of such payment under the Code, or any provision of state, local or foreign Law, and such withheld and deducted amounts will be treated for all purposes of this Agreement as having been paid to the applicable payee.

#### 1.4 Purchase Price Adjustment.

(a) Adjustment at Closing. At least three (3) Business Days prior to the Closing Date, Seller shall deliver to Buyer a written statement (the "Estimated Closing Statement"), which statement shall set forth Seller's good faith calculation and estimate of (i) Closing Cash, (ii) Net Working Capital Amount, (iii) Company Debt and (iv) Unpaid Transaction Expenses (clauses (i) through (iv) inclusive, the "Purchase Price Elements") and (v) the Purchase Price based thereon (the "Estimated Purchase Price") together with supporting documentation for such estimates reasonably requested by Buyer, including, where applicable,

invoices for Unpaid Transaction Expenses. The Estimated Closing Statement shall be prepared in accordance with the terms of (including definitions contained in) this Agreement and the Accounting Principles. Seller shall provide, or cause to be provided by the Company, to Buyer and its Representatives reasonable access to all the properties, books, Contracts and records of the Company and such Representatives of the Company (including the Company's accountants) relevant to Buyer's review of the Estimated Closing Statement in accordance with this Section 1.4(a). Seller shall review comments proposed by Buyer with respect to the foregoing and will consider (in good faith) and incorporate any changes it reasonably deems appropriate to the Estimated Closing Statement prior to the Closing. For the purposes of this Agreement, "Estimated Net Working Capital Amount" means the Net Working Capital Amount, "Estimated Company Debt" means the Company Debt, "Estimated Closing Cash" means the Closing Cash, "Estimated Unpaid Transaction Expenses" means the Unpaid Transaction Expenses, in each case, as set forth on the Estimated Closing Statement, subject to the immediately foregoing sentence.

(b) Adjustment After Closing. After the Closing, the Purchase Price shall be (i) reduced by (A) the amount, if any, by which the Estimated Net Working Capital Amount exceeds the Final Net Working Capital Amount, (B) the amount, if any, that the Final Company Debt exceeds the Estimated Company Debt, (C) the amount, if any, that the Estimated Closing Cash exceeds the Final Closing Cash and (D) the amount, if any, that the Final Unpaid Transaction Expenses exceed the Estimated Unpaid Transaction Expenses (the "Post-Closing Reductions"), and (ii) increased by (A) the amount, if any, by which the Final Net Working Capital Amount exceeds the Estimated Net Working Capital Amount, (B) the amount, if any, that Estimated Company Debt exceeds Final Company Debt, (C) the amount, if any, that the Final Closing Cash exceeds the Estimated Closing Cash and (D) the amount, if any, that the Estimated Unpaid Transaction Expenses exceed the Final Unpaid Transaction Expenses (the "Post-Closing Additions"), in each case, in accordance with this Section 1.4. A "Post-Closing Net Reduction" means the amount, if any, by which the aggregate Post-Closing Reductions exceed the aggregate Post Closing Additions, and a "Post-Closing Net Addition" means the amount, if any, by which the aggregate Post-Closing Additions exceed the aggregate Post-Closing Reductions. For the purposes of this Agreement, "Final Net Working Capital Amount" means the Net Working Capital Amount, "Final Company Debt" means the Company Debt, "Final Closing Cash" means the Closing Cash, "Final Unpaid Transaction Expenses" means the Unpaid Transaction Expenses, in each case, as finally agreed or determined in accordance with Section 1.4(d).

(c) After the Closing Statement and the calculation of the Purchase Price Elements become final and binding upon the parties in accordance with the provisions in Section 1.4(d) below, then, within ten (10) days following such calculation: (i) if any Post-Closing Net Reduction has been determined pursuant to Section 1.4(b), Buyer and Seller shall provide a joint written instruction to the Escrow Agent to release (A) to Buyer an amount of cash equal to the Post-Closing Net Reduction; *provided*, that to the extent the Post-Closing Net Reduction is greater than the amount remaining in the Adjustment Escrow Fund, Seller shall pay, or cause to be paid, to Buyer, by wire transfer of immediately available funds to an account designated in writing by Buyer to Seller, an amount equal to such shortfall and (B) to Seller any amounts remaining in the Adjustment Escrow Fund after the release of funds to Buyer pursuant to the foregoing clause (A), (ii) if any Post-Closing Net Addition has been determined pursuant

to Section 1.4(b), (A) Buyer shall deliver to Seller such Post-Closing Net Addition, by wire transfer of immediately available funds to the account designated in writing by Seller to Buyer and (B) Buyer and Seller shall provide a joint written instruction to the Escrow Agent to release to Seller all amounts held in the Adjustment Escrow Fund and (iii) if the Post-Closing Additions equal the Post-Closing Reductions, Buyer and Seller shall provide a joint written instruction to the Escrow Agent to release to Seller the amounts held in the Adjustment Escrow Fund.

(d) Closing Statement.

(i) As soon as practicable after the Closing Date, but no later than the ninetieth (90th) day after the Closing Date, Buyer shall prepare, or cause to be prepared, at the Company's cost, and deliver to Seller a statement (the "Closing Statement") setting forth Buyer's good faith calculation of the Purchase Price and each of the Purchase Price Elements, in each case, together with supporting documentation for such calculations reasonably requested by Seller. The Closing Statement shall be prepared in accordance with the terms of (including definitions contained in) this Agreement and the Accounting Principles. Buyer shall afford, and shall cause the Company to afford, to Seller and any accountants, counsel or financial advisers retained by Seller in connection with the review of Closing Statement in accordance with this Section 1.4(d), reasonable access to all the properties, books, Contracts and records of the Company and such Representatives of the Company (including the Company's accountants) relevant to the review of the Closing Statement and Buyer's determination of Purchase Price Elements; *provided*, that (w) Seller shall have executed customary access and confidentiality agreements (to the extent not already executed), (x) work papers of the Company's accountants shall be made available only if permitted by such accountants (it being agreed that Buyer shall use commercially reasonable efforts to cause such accountants to permit such access to their work papers), (y) such access or furnishing of information shall be conducted during normal business hours and upon reasonable request and upon reasonable advance notice, and in a manner not to interfere with the businesses or operations of the Company and (z) Buyer may, and may cause the Company to, withhold access to any information that is subject to confidentiality obligations prohibiting disclosure or if disclosed, such information would result (in Buyer's reasonable discretion in consultation with counsel) in a waiver of attorney-client privilege or other legal privilege. If Seller objects that any of the Purchase Price Elements or the Purchase Price as set forth in the Closing Statement were not calculated in accordance with the Accounting Principles (to the extent applicable) or the other terms of this Agreement, Seller shall within forty-five (45) days after receipt thereof notify Buyer of the same in writing (an "Objection Notice"), which notice shall specify the disputed item(s) or amount(s), the basis of such objection(s) in reasonable detail and Seller's proposed modification of such calculation, item(s) or amount(s). If Seller does not deliver an Objection Notice within such forty-five (45) day period, the Closing Statement and the calculations of Purchase price and the Purchase Price Elements therein shall be final, conclusive and binding on the parties.

(ii) If Seller objects in accordance with Section 1.4(d)(i) above and Buyer, within twenty (20) days after receipt of the Objection Notice, provides written notice to Seller that Buyer disagrees with all or any portion of Seller's Objection Notice (a "Notice of Disagreement"), the parties shall negotiate in good faith to reach an agreement during the fifteen (15) day period following delivery of such Notice of Disagreement from Buyer to Seller (the "Resolution Period"), and all such negotiations and communications related thereto shall (unless



otherwise agreed by Buyer and Seller in writing) be governed by Rule 408 of the Federal Rules of Evidence and any applicable similar state rule. If Buyer does not provide a Notice of Disagreement to Seller within such twenty (20) day period after receiving an Objection Notice from Seller, the Closing Statement, with Seller's proposed modifications as set forth in the Objection Notice, shall be final, conclusive and binding on the parties.

(iii) If, upon completion of the Resolution Period, Buyer and Seller are unable to reach an agreement with respect to the matters in dispute set forth in the Notice of Disagreement, they shall promptly thereafter submit to the Independent Accounting Firm for arbitration, in accordance with the standards set forth in this Section 1.4(d), the items or amounts so remaining in dispute. The Independent Accounting Firm shall consider only those items or amounts in the Closing Statement or the calculation of the Purchase Price Elements, with respect to which Buyer and Seller have disagreed, as set forth in the Notice of Disagreement, and been unable to reach agreement (the "Unresolved Matters"). The Independent Accounting Firm shall deliver to Seller and Buyer, as promptly as practicable, a determination of the Unresolved Matters; *provided*, that Buyer and Seller shall use reasonable efforts to cause the Independent Accounting Firm to render a written decision about the Unresolved Matters submitted to the Independent Accounting Firm within thirty (30) days of the receipt of such submission. The scope of the disputes to be resolved by the Independent Accounting Firm shall be limited to fixing mathematical errors and determining whether the Unresolved Matters were determined in accordance with the Accounting Principles, as applicable, and the other terms of this Agreement and the Independent Accountant is not to make any other determination. The Independent Accounting Firm's decision shall be based solely on written submissions by Buyer and Seller and their respective Representatives (a copy of which shall be delivered to Buyer or Seller, as applicable) and not by independent review, and it shall not permit or authorize discovery or hear testimony. The Independent Accounting Firm's determination as to each Unresolved Matter shall (A) be set forth in writing, (B) be within the range of dispute between Buyer and Seller and (C) constitute an arbitral award. The fees and expenses of the Independent Accounting Firm and of any enforcement of its determination(s), shall be borne by Buyer and Seller in inverse proportion as they may prevail on the matters resolved by the Independent Accounting Firm, which proportionate allocation shall be calculated on an aggregate basis based on the relative dollar values of the amounts in dispute and shall be determined by the Independent Accounting Firm at the time of its resolution of the matters in dispute. All determinations made by the Independent Accounting Firm will, absent manifest error, be final, conclusive and binding on the parties. Judgment may be entered upon the determination of the Independent Accounting Firm in any court having jurisdiction over the party against which such determination is to be enforced.

(e) All payments made pursuant to this Section 1.4 shall be treated as adjustments to the Estimated Purchase Price for applicable Tax purposes.

1.5 Seller's Deliveries. At or prior to the Closing, Seller shall deliver to Buyer:

(a) The Unit certificate(s) (or other valid instrument evidencing ownership) representing all of the Units, duly endorsed in blank, or Unit transfer powers and/or other documents, endorsed by Seller, sufficient to transfer the Units to Buyer;

(b) a certificate of the Chief Financial Officer of Seller, dated the Closing Date, certifying to Buyer the matters set forth in Sections 5.2(a)–5.2(c);

(c) the Payoff Letters, duly executed by the Payoff Lenders;

(d) payoff letters relating to the Unpaid Transaction Expenses;

(e) resignations by all governors of the Company;

(f) UCC-3 termination statements or other documentation reasonably satisfactory to Buyer to evidence the termination of Liens, if any, securing the Company Debt;

(g) a non-foreign status certificate satisfying the requirements of Treasury Regulations Section 1.1445-2(b)(2) in a form reasonably acceptable to Buyer;

(h) the Escrow Agreement, executed by Seller; and

(i) the IP License Side Letter, executed by each of the parties thereto;

(j) the Transition Services Agreement, executed by each of the parties thereto;

(k) the Seller Affiliate Support Agreement, executed by Seller and each of its Affiliates party thereto;

(l) the Affiliate Lease Amendments, executed by each of the parties thereto; and

(m) all other agreements, documents, instruments, or certificates required to be delivered by Seller or the Company at or prior to the Closing pursuant to Section 5.2.

1.6 Buyer's Deliveries. At or prior to the Closing, Buyer shall deliver:

(a) To Seller:

(i) a certificate of an officer of Buyer, dated the Closing Date, certifying to Seller the matters set forth in Section 5.3(a) and 5.3(b);

(ii) the Escrow Agreement, executed by Buyer;

(iii) the Seller Affiliate Support Agreement, executed by Buyer; and

(iv) unless Seller and Buyer agree, in writing, otherwise, a commitment or other evidence satisfactory to Seller's counsel that the Buyer will have a replacement letter of credit in place immediately upon the Closing to replace the Purchased Aircraft Letter of Credit;

(v) all other agreements, documents, instruments, or certificates required to be delivered by Buyer at or prior to the Closing pursuant to Section 5.3.

1.7 Closing. The closing of the transactions contemplated hereby (the “Closing”) will take place at 10:00 a.m., Minneapolis time, at the offices of Briggs and Morgan, P.A. at 2200 IDS Center, 80 S. 8<sup>th</sup> Street, Minneapolis, MN, 55402, or via email with overnight delivery of originals to follow, no later than the third (3<sup>rd</sup>) Business Day following the satisfaction or waiver by the appropriate party of the conditions contained in Article VI other than those conditions which, by their terms, are to be satisfied at Closing, but subject to the satisfaction or waiver of such conditions at Closing, or on such other place or at such other date and time as may be mutually agreed to by the parties (“Closing Date”). All proceedings to be taken and all documents to be executed and delivered by the parties at the Closing will be deemed to have been taken and executed simultaneously and no proceedings will be deemed to have been taken nor documents executed or delivered until all have been taken, executed and delivered.

1.8 Tax Treatment. Seller and the Buyer Parties agree that the transfer of Units pursuant to this Agreement will be treated for U.S. federal income tax purposes as a taxable sale of the assets of the Company and shall report consistently. Neither Seller nor the Buyer Parties shall take any position (whether in audits, on Tax Returns or otherwise) that is inconsistent with the foregoing unless required to do so by applicable Law.

1.9 Allocation. Within ninety (90) days after the Closing Date, Buyer shall prepare and deliver to Seller a schedule in writing (an “Allocation Schedule”) allocating the consideration paid or deemed paid by Buyer pursuant to this Agreement as determined for Tax purposes among the assets of the Company, in a manner consistent with Section 1060 of the Internal Revenue Code of 1986, as amended (the “Code”) and the regulations thereunder. Seller shall have a period of thirty (30) days after the delivery of the Allocation Schedule to present in writing to Buyer notice of any objections that Seller may have to the allocations set forth therein. Unless Seller timely objects, such Allocation Schedule shall be binding on the parties, without further adjustment. If Seller timely objects, Seller and Buyer shall negotiate in good faith and use their reasonable best efforts to resolve any dispute. If the parties do not resolve any dispute in accordance with the preceding sentence, the dispute mechanics of Section 1.4(d) shall apply to this Section 1.9 *mutatis mutandis*. Any subsequent adjustments to the Estimated Purchase Price pursuant to the terms of this Agreement shall be reflected in amendments to the Allocation Schedule prepared by Buyer and delivered to Seller subject to the review, objection and dispute mechanics set forth in the prior sentences of this Section 1.9. Buyer and Seller shall file all Tax Returns consistent with the terms of this Agreement unless otherwise required by a change in applicable Law.

## ARTICLE II

### REPRESENTATIONS AND WARRANTIES OF SELLER

Except as disclosed in the disclosure schedule (the “Seller Disclosure Schedule”) delivered by Seller to Buyer prior to execution of this Agreement (which sets forth items of disclosure; it being understood that matters disclosed pursuant to one section of the Seller

Disclosure Schedule shall be deemed to be disclosed with respect to other sections where it is reasonably apparent on the face of the disclosure, that the matters so disclosed are also applicable to such other sections), Seller represents and warrants to Buyer, as of the date hereof and as of the Closing Date, as follows:

2.1 Organization and Authority of Seller.

(a) Seller is a limited liability company duly organized, validly existing and in good standing under the Laws of the State of Minnesota.

(b) Seller has all requisite limited liability company power and authority to enter into this Agreement and each of the other Transaction Documents to which it is a party, to carry out its obligations hereunder and thereunder, and to consummate the Contemplated Transactions. The execution by Seller of this Agreement and each of the other Transaction Documents to which it is a party and the consummation of the Contemplated Transactions have been duly and validly authorized by all required limited liability company action on the part of Seller, and no other proceedings on the part of Seller are required to authorize this Agreement or any of the other Transaction Documents to which it is a party or the consummation of the Contemplated Transactions. This Agreement and each of the other Transaction Documents to which Seller is a party has been duly and validly executed and delivered by Seller and, assuming due authorization, execution and delivery by Buyer Parties, constitutes the valid and binding obligation of Seller, enforceable against Seller in accordance with its terms, except that (i) such enforcement may be subject to applicable bankruptcy, insolvency or other similar Laws, now or hereafter in effect, affecting creditors' rights generally and (ii) the remedy of specific performance and injunctive and other forms of equitable relief may be subject to equitable defenses and to the discretion of the court before which any proceeding therefor may be brought.

2.2 Organization, Authority and Qualification of the Company.

(a) The Company is a limited liability company duly organized, validly existing and in good standing under the Laws of the State of Minnesota.

(b) The Company has all requisite limited liability company power and authority to own, lease and operate its properties and assets and to carry on its Business as it is now being conducted. The Company is duly qualified to do business and is in good standing (to the extent such concept is applicable) in each jurisdiction where the ownership, leasing or operation of its properties or assets or the conduct of its Business requires such qualification, except where the failure to be so qualified or in good standing, individually or in the aggregate, would not (i) be material to the Company or (ii) prevent, materially delay or materially impair the ability of the Company to perform its obligations under this Agreement or to consummate the Contemplated Transactions. The Company is not in violation of, in conflict with, or in default under, any provision of the Company's Organizational Documents. Seller has made available to Buyer true, correct and complete copies of the Organizational Documents of the Company as in effect on the date hereof.

## 2.3 Capitalization.

(a) The Company has 100,000,000 limited liability company interests authorized, issued and outstanding, which constitutes all of the Units. All of the Units have been duly authorized and validly issued in compliance with all applicable securities Laws and are fully paid and nonassessable and free of preemptive rights. All of the Units are owned by Seller, as record and beneficial owner, free and clear of all Liens. Upon delivery to Buyer at the Closing of certificates representing the Units (or other valid instrument evidencing ownership), duly endorsed by Seller for transfer to Buyer, and upon receipt of the portion of the Estimated Purchase Price payable to Seller pursuant to Section 1.3(b), good and valid title to the Units will pass to Buyer, free and clear of any Liens, other than those arising from acts of Buyer or its Affiliates and Liens on transfer imposed under applicable securities Laws.

(b) There are no issued, reserved for issuance or outstanding (i) Equity Interests of the Company other than the Units, (ii) options, warrants, calls, conversion rights, restricted units, membership unit appreciation rights, performance units, contingent value rights, "phantom" unit rights, interests in or rights to the ownership or earnings of the Company (including any securities or rights that are derivative of, or provide economic benefits based, directly or indirectly, on the value or price of any limited liability company or other ownership interests in the Company) or any other equity equivalent or equity-based award or right, redemption rights, repurchase rights or other preemptive or outstanding rights, agreements, arrangements or commitments of any character obligating the Company to issue, acquire or sell any Units or other Equity Interests of the Company or any securities obligations convertible or exchangeable into or exercisable for, or giving any Person a right to subscribe for or acquire, any securities of the Company (whether from the Company, Seller or otherwise), and no securities or obligations evidencing such rights are authorized, issued or outstanding, or (ii) except as set forth in the Second Amended and Restated Member Control Agreement of the Company, dated October 20, 2011, voting trusts, proxies, voting agreements or other similar agreements or understandings to which the Company is a party or by which Seller is bound with respect to the voting of any Units or other Equity Interests in the Company.

(c) There are no outstanding contractual obligations or commitments of the Company of any character (i) except as set forth in the Second Amended and Restated Member Control Agreement of the Company, dated October 20, 2011, affecting the voting rights of, (ii) requiring the repurchase, redemption or disposition of, or containing any right of first refusal with respect to, (iii) requiring the registration for sale of, (iv) granting any preemptive or antidilutive rights with respect to, or (iv) restricting the transfer of, any Units or other Equity Interests in the Company.

(d) There are no outstanding bonds, debentures, notes or other Indebtedness or other obligations of Seller or the Company that have the right to vote (or are convertible into or exercisable or exchangeable for securities having the right to vote) on any matters on which members of the Company may vote.

(e) The Company does not have any Subsidiaries and does not own any Equity Interests or other securities in any other Persons whether or not Subsidiaries.

2.4 No Conflict. None of the execution, delivery or performance of the Transaction Documents by Seller, the consummation by Seller of the Contemplated Transactions, or Seller's compliance with any of the provisions of any Transaction Document will (with or without notice or lapse of time, or both): (a) conflict with or violate any provision of Seller's or the Company's Organizational Documents; (b) assuming that all consents, approvals, authorizations and permits described in Section 2.5 have been obtained and all filings and notifications described in Section 2.5 have been made and any waiting periods thereunder have terminated or expired, (i) conflict with or violate any Law applicable to Seller, the Company or any of Seller or the Company's properties or assets (including the Units); or (ii) require any consent or approval under, result in any breach of or any loss of any benefit under, or violate or conflict with, constitute a default (or an event which with notice or lapse of time or both would become a default), or result in termination of or accelerate the performance required by, or give to others any right of termination, acceleration, purchase, sale, modification or cancellation under any Contract binding on Seller or the Company or any Permit; or (c) result in the creation or imposition of any Lien, other than Permitted Liens, upon the Units or any of the rights, properties or assets of the Company, except, with respect to clauses (b) and (c), (x) with respect to Seller, for any such conflicts, violations, consents, breaches, losses, defaults, other occurrences or Liens which, individually or in the aggregate, would not reasonably be expected to materially impair or delay Seller's ability to perform its obligations under any Transaction Document or to consummate the Contemplated Transactions and (y) with respect to the Company, for any such conflicts, violations, consents, breaches, losses, defaults, other occurrences or Liens which, individually or in the aggregate, would not reasonably be expected to be material to the Company.

2.5 Required Filings and Consents. None of the execution, delivery or performance of this Agreement or any other Transaction Document by Seller or the Company (as applicable), or the consummation of any transaction contemplated hereby or thereby, or Seller's or the Company's compliance with, or taking action to comply with, any of the provisions of any Transaction Document will require (with or without notice or lapse of time, or both) any consent, approval, authorization or permit of, or filing or registration with or notification to, any Governmental Entity, other than:

(a) in compliance with any applicable requirements of the HSR Act,

(b) as required to be made or obtained under Title 49 of the United States Code or under any regulation, rule, order, notice or policy of the U.S. Federal Aviation Administration (the "FAA"), the U.S. Department of Transportation (the "DOT"), the Federal Communications Commission (the "FCC") and the U.S. Department of Homeland Security (the "DHS"), including the U.S. Transportation Security Administration (the "TSA") and collectively with the FAA, FCC, DOT and DHS, the "Aviation Regulations"),

(c) the consents, approvals, authorizations or permits of, or filings or registrations with or notifications to Governmental Entities as set forth on Section 2.5(c) of the Seller Disclosure Schedule, and

(d) any actions or filings resulting solely from the identity of the Buyer Parties or their Affiliates.

## 2.6 Permits; Compliance With Law.

(a) The Company holds all authorizations, permits, certificates, exemptions, approvals, orders, consents, franchises, variances, exemptions, registrations, licenses and clearances of any Governmental Entity (the "Permits") necessary for the operation of the Business, except where the failure to hold any such Permit would not be material to the Company or to the operation of the Business as conducted as of the date hereof and as of the Closing Date, and is in material compliance with such Permits. All Permits are valid and in full force and effect and no suspension, cancellation or non-renewal of any Permit is pending, or to the Knowledge of the Company, threatened. The Company is not, and since January 1, 2016, has not been, in material violation or material breach of, or material default under, any Permit and since January 1, 2016, the Company has not been notified in writing that any Permit may not in the ordinary course be renewed upon its expiration or that any Permit may be terminated, materially amended or not granted or renewed, in each case, which has not been remedied. No event or condition has occurred or exists which would reasonably be expected to (i) result in a violation of, breach of, loss of a benefit under or revocation, termination or non-renewal of, any Permit (in each case, with or without notice or lapse of time or both) or (ii) have or cause a material and adverse effect on the Company or the operation of the Business as conducted as of the date hereof and as of the Closing Date.

(b) Except as would not reasonably be expected to be material to the Company or the operation of the Business, (i) to the Knowledge of the Company, no proceeding, investigation or review by any Governmental Entity concerning the Company is pending with respect to a violation by the Company of any Law applicable to the Company or by which any property or asset of the Company is bound, including, without limitation, violations of operating certificates, certificates of public convenience and necessity, air carrier obligations, airworthiness directives, Aviation Regulations and any other rules, regulations, directives, orders and policies of the FAA, the DOT, the DHS, the FCC, the TSA or any other Governmental Entity; and (ii) the Company has timely filed all material submissions, reports, registrations, schedules, forms, statements and other documents, together with any amendments required to be made with respect thereto, that were required to be filed under applicable Aviation Regulations.

(c) To the Knowledge of the Company and Seller, neither the Company nor any of its directors, officers, employees, or agents (in each case acting for the benefit of the Company):

(i) has provided, promised, or authorized the provision of any contribution, gift, entertainment or other expenses relating to political activity, or any other money, property, or thing of value, directly or indirectly, to any Government Official, or any other Person acting in an official capacity, to influence official action or secure an improper advantage, or to encourage the recipient to breach a duty of good faith or loyalty or the policies of his/her employer, or otherwise violated any Anticorruption Law;

(ii) is a Sanctioned Person nor has transacted any business directly or indirectly with any Sanctioned Person in violation of Sanctions, nor otherwise violated Sanctions; nor

(iii) has violated any Export Control Laws.

(d) The Company has instituted, maintains, and has adhered to policies reasonably designed to comply with applicable Anticorruption Laws.

(e) To the Knowledge of the Company and Seller, (i) there is no pending investigation of or outstanding request for information from the Company by any Governmental Entity regarding Anticorruption Laws, Sanctions, or Export Control Laws, and (ii) there is not pending any other allegation, investigation or inquiry regarding Seller's actual or possible violation of Anticorruption Laws, Sanctions, or Export Control Laws that reasonably could be expected to have an adverse effect on the Company or the operation of the Business as conducted as of the date hereof and as of the Closing Date.

## 2.7 Financial Statements.

(a) Seller has Made Available to Buyer true, complete and accurate copies of the Company's (i) audited financial statements consisting of the balance sheet of the Company as of December 31, 2016, 2015, and 2014 and the related statements of income and retained earnings, members' equity and cash flow for the years then ended (the "Company Audited Financial Statements"), and (ii) unaudited financial statements consisting of the balance sheet of the Company as of October 31, 2017 and the related statements of income and retained earnings, members' equity and cash flow for the ten-month period then ended (the "Company Interim Financial Statements") and together with the Company Audited Financial Statements, the "Company Financial Statements"). The Company Financial Statements have been prepared in accordance with GAAP applied on a consistent basis throughout the period involved, subject, in the case of the Company Interim Financial Statements, to normal and recurring year-end adjustments, none of which are material either individually or in the aggregate, and the absence of notes, none of which, if presented, would differ materially from those presented in the Company Audited Financial Statements. The Company Financial Statements are true, accurate, complete and fairly present, in all material respects, the financial condition of the Company as of the respective dates they were prepared and the results of the operations of the Company for the periods indicated.

(b) Except as set forth in the Company Financial Statements, the Company does not maintain any "off-balance sheet arrangement" within the meaning of Item 303 of Regulation S-K of the Securities and Exchange Commission.

2.8 No Undisclosed Liabilities. Except Liabilities (a) identified on Section 2.8 of the Seller Disclosure Schedule, (b) specifically disclosed or reserved for in the Company's unaudited balance sheet as of October 31, 2017 included in the Company Interim Financial Statements, (c) for performance under Material Contracts listed on Section 2.12(a) of the Seller Disclosure Schedule (excluding any Liability for breach), (d) incurred in the Ordinary Course of Business consistent with past practice, or (e) incurred as a result of actions taken by the Company according to the process described in the Company Growth Plan, since October 31, 2017, the Company has no Liabilities required by GAAP to be set forth on a balance sheet of the Company that would reasonably be expected to be, individually or in the aggregate, material to the Company.



## 2.9 Absence of Certain Changes or Events.

(a) Other than actions taken by the Company pursuant to the Company Growth Plan, since October 31, 2017, until the date of this Agreement, Seller has conducted its businesses in all material respects in the Ordinary Course of Business.

(b) Since October 31, 2017, until the date of this Agreement, Seller has not taken any action that, if taken after the date of this Agreement without the prior written consent of Buyer, would constitute a breach of any of the covenants set forth in Section 4.1(b).

(c) Since October 31, 2017, until the date of this Agreement, there has been no Material Adverse Effect.

## 2.10 Employee Benefit Plans.

(a) Section 2.10(a) of the Seller Disclosure Schedule sets forth a complete and accurate list of each Company Benefit Plan. With respect to each Company Benefit Plan, the Company has provided to Buyer complete, current and accurate copies of (i) each such Company Benefit Plan, including any material amendments thereto, (ii) each trust, insurance, administrative service, annuity or other funding Contract related thereto, (iii) all summary plan descriptions and summary of material modifications, (iv) the most recently received IRS determination letter or opinion letter, if any, issued by the IRS with respect to any Company Benefit Plan that is intended to qualify under Section 401(a) of the Code, and (v) for the three (3) most recent years (A) each annual report on Form 5500 (and all schedules thereto) required to be filed with the IRS with respect thereto, (B) actuarial or other valuation reports, and (C) all other material filings and material correspondence with any Governmental Entity (including any correspondence regarding the operation or administration of any Company Benefit Plan and actual or, to the Knowledge of the Company, threatened audits or investigations) with respect to each Company Benefit Plan.

(b) Except as would not, individually or in the aggregate, reasonably be expected to result in material liability to the Company, (i) each Company Benefit Plan (and any related trust or other funding vehicle) has been established, maintained and administered in accordance with its terms and is in compliance with ERISA, the Code and all other applicable Laws, (ii) with respect to each Company Benefit Plan, all reports, returns, notices and other documentation required to have been filed with or furnished to any Governmental Entity or to the participants or beneficiaries of such Company Benefit Plan, have been filed or furnished on a timely basis, and (iii) no individual who has performed services for the Company or any of its Subsidiaries has been improperly excluded from participation in any Company Benefit Plan.

(c) The Company does not contribute to, sponsor or maintain any Foreign Benefit Plans.

(d) To the Knowledge of the Company, (i) each Company Benefit Plan that is intended to be qualified under Section 401(a) of the Code so qualifies, and (ii) none of the Company, any Company Benefit Plan, any trustee, administrator or other third-party fiduciary or party-in-interest, with respect to any Company Benefit Plan, has engaged in any breach of fiduciary responsibility or non-exempt prohibited transaction (within the meaning of

Section 406 of ERISA or Section 4975 of the Code) which could result in the imposition of a material penalty assessed pursuant to Section 502(i) of ERISA or a material Tax imposed by Section 4975 of the Code on the Company.

(e) No Company Benefit Plan is, and neither the Company nor any ERISA Affiliate thereof sponsors, maintains, contributes to, or has ever sponsored, maintained, contributed to, or has any actual or contingent liability with respect to any (i) single employer plan or other pension plan that is subject to Section 302 or Title IV of ERISA or Section 412 of the Code, (ii) "multiple employer plan" within the meaning of Section 413(c) of the Code, (iii) any "multiemployer plan" within the meaning of Section 3(37) of ERISA or (iv) multiple employer welfare arrangement (within the meaning of Section 3(4) of ERISA).

(f) None of the execution, delivery or performance of this Agreement by Seller, the consummation by Seller or the Company of any transaction contemplated by this Agreement, nor Seller's compliance with any of the provisions of this Agreement, including any termination of employment on or prior to Closing Date, will result in any "parachute payment" under Section 280G of the Code.

(g) The Company does not have any liability in respect of, or obligation to provide, post-retirement health, medical, disability, life insurance benefits or other welfare benefits for participants in the Company Benefit Plans (or the spouses, dependent or beneficiaries of any such participants), whether under a Company Benefit Plan or otherwise, except as required to comply with Section 4980B of the Code or any similar law.

(h) None of the execution, delivery or performance of this Agreement by Seller or any transaction contemplated by this Agreement, or the Company's compliance with any of the provisions of this Agreement (either alone or in combination with another event) will (i) entitle any participant in the Company Benefit Plans to any compensation or benefit, (ii) accelerate the time of payment or vesting, increase the amount of payment, or trigger any payment or funding, of any compensation or benefit or trigger any other material obligation under any Company Benefit Plan, (iii) trigger any funding (through a grantor trust or otherwise) of compensation, equity award or other benefits or (iv) otherwise give rise to any material liability under any Company Benefit Plan.

(i) No Company Benefit Plan provides for any gross-up, reimbursement or additional payment by reason of any Tax imposed under Section 409A or Section 4999 of the Code.

(j) Each "nonqualified deferred compensation plan" (as defined in Section 409A(d)(1) of the Code) maintained or sponsored by the Company has been operated in material compliance with Section 409A of the Code and the guidance issued thereunder and the document or documents that evidence each such plan have conformed to the provisions of Section 409A of the Code and the guidelines issued thereunder in all material regards. No Company Equity Interest (whether currently outstanding or previously exercised) is, has been or would be, as applicable, subject to any tax, penalty or interest under Section 409A of the Code.

(k) No action, lien, suit or claim (excluding claims for benefits incurred in the ordinary course) has been brought or is pending or threatened against or with respect to any Company Benefit Plan or the assets or any fiduciary thereof (in that Person's capacity as a fiduciary of such Company Benefit Plan) that would result in material liability to the Company. There are no inquiries, audits or other Proceedings pending or, to the Knowledge of the Company, threatened by the IRS or other Governmental Entity with respect to any Company Benefit Plan that reasonably would be expected to have or to cause material liability to the Company. To the Knowledge of the Company, no facts or circumstances exist that could give rise to any such action, lien, suit or claim with respect to any Company Benefit Plan.

#### 2.11 Labor and Other Employment Matters.

(a) The Company is in compliance with all applicable Laws respecting labor, employment, immigration, fair employment practices, terms and conditions of employment, workers' compensation, occupational safety, plant closings, employee classification, compensation and benefits, and wages and hours, except where failure to so comply reasonably would not be expected, individually or in the aggregate, to result in material liability to the Company.

(b) Except as set forth in Section 2.11(b) of the Seller Disclosure Schedule, there are no collective bargaining agreements or other labor union Contracts applicable to any Company employee in effect as of the date of this Agreement with respect to their employment with the Company, nor is any such agreement being negotiated.

(c) In the past three (3) years, there have been no labor strikes, slowdowns, work stoppages, picketings, concerted refusal to work overtime, handbilling, demonstrations, leafletting, or lockouts against or involving the Company and none are pending, or, to the Knowledge of the Company, threatened. The Company is not a party to any agreement, arrangement or understanding, whether written or oral, with any union, trade union, works council or other employee representative body or any material number or category of its employees that would prevent or materially restrict or impede the consummation of the Contemplated Transactions.

(d) To the Knowledge of the Company, no labor union, labor organization or works council has made a pending demand for recognition or certification to the Company, and there are no representation or certification proceedings or petitions seeking a representation proceeding presently pending.

(e) Except as would not, individually or in the aggregate reasonably be expected to result in a material liability to the Company, there is no unfair labor practice Proceeding pending against the Company before any Governmental Entity and there is no pending or, to the Knowledge of the Company, threatened grievance, charge, complaint, audit or investigation by or before any Governmental Entity with respect to any collective bargaining agreement or other labor union Contracts.

(f) The Company has not incurred any liability or obligation under the Worker Adjustment and Retraining Notification Act and the regulations promulgated thereunder, or any similar state or local law that remains unsatisfied.

## 2.12 Contracts.

(a) Section 2.12(a) of the Seller Disclosure Schedule sets forth an accurate and complete list of each Contract to which the Company is a party, or to which the Company's assets, rights, property or business are bound or subject, and which falls within any of the following categories:

(i) any maintenance Contracts for repair and overhaul that would be expected to result in the Company incurring costs in excess of \$1,000,000 in the twelve (12)-month period following the date hereof;

(ii) any Contract relating to (A) the creation, incurrence, assumption or guarantee by the Company of any Indebtedness (including surety bonds, performance bonds or letters of credit in excess of \$100,000) or (B) any loan or advance by the Company to any Person other than advances for travel and other normal business expenses to officers and employees in the Ordinary Course of Business;

(iii) any Contract under which the Company is a lessor of or permits any third party to hold or operate any personal property owned or controlled by it which involves consideration in excess of \$250,000 or a group of Contracts with the same Person which involve consideration in excess of \$500,000 in the aggregate (other than any capital leases or Contracts disclosed pursuant to clause (xxi) below);

(iv) any material credit card-related Contracts, including (A) all material credit card processing or card services Contracts, merchant services Contracts and on-line payment services Contracts, (B) all material Contracts with credit card or debit card issuers or card associations governing co-branded credit or debit cards and (C) all material Contracts governing participation in credit card related awards programs;

(v) any Real Property Lease;

(vi) any Contract that is a collective bargaining agreement;

(vii) any Contract in respect of a joint venture, partnership, business alliance;

(viii) any (x) interline, code sharing, capacity purchase or pro rate agreement or similar arrangement involving consideration from or to the Company of more than \$1,000,000 in the twelve (12)-month period prior to the date of this Agreement or (y) online travel agency or corporate travel Contract (other than charter Contracts) involving commissions from or to the Company of more than \$1,000,000 in the twelve (12)-month period prior to the date of this Agreement;

(ix) any global distribution system;

(x) any Contract regarding the purchase or lease of any Company Slot;

(xi) any Contract that obligates the Company to make any capital expenditure or any acquisition or construction of fixed assets for or in respect of any real property, in each case in an amount in excess of \$500,000 in any calendar year;

(xii) any Contract not disclosed pursuant to the other subsections of this Section 2.12(a) that by its terms is reasonably expected to result in (A) minimum payments to the Company under such Contract of more than \$250,000 in the twelve (12)-month period following the date of this Agreement, (B) minimum payments from the Company under such Contract of more than \$1,000,000 in the twelve (12)-month period following the date of this Agreement or (C) has five (5) years or more remaining in its term, provides for payments to or from the Company under such Contract following the date of this Agreement in excess of \$1,000,000 annually or \$5,000,000 in the aggregate and cannot be cancelled by the Company upon notice of ninety (90) days or less;

(xiii) any Contract relating to an acquisition, divestiture, merger or similar transaction of any business or a material amount of Equity Interests or substantially all of the assets of any Person (whether by merger, sale of stock, sale of assets or otherwise) that is pending, or pursuant to which the Company has any material contingent payment or indemnification obligations or relating to a completed transaction within the last three (3) years;

(xiv) any Contract (i) granting any Person a Lien on any material tangible or intangible assets of the Company, other than Permitted Liens or (ii) limiting the ability of the Company to incur Indebtedness, pay or make any dividends or distributions, or create Liens on material assets, rights or properties owned by the Company;

(xv) any Contract that (i) limits or restricts the Company from competing in any line of business with any Person or in any geographic region, (ii) "most favored nations" terms or establishes an exclusive sale or purchase obligation with respect to any product, service or geographic area, (iii) a "right of first offer" or "right of first refusal" on behalf of any other Person to acquire Company or any assets or business or product lines thereof;

(xvi) any Contract pursuant to which the Company is licensing or otherwise granting rights in or to any of the Material Intellectual Property to any Person (including via a covenant not to sue) or any Person licensing or sublicensing to the Company, or otherwise authorized the Company to use, any third-party Intellectual Property Rights that are material to the Business as currently conducted (excluding any Contract that is a non-exclusive license of standard, unmodified, off-the-shelf Software in object code form solely for internal use and that is commercially available on standard terms from third-party vendors for fees of less than \$1,000,000 per annum), other than any non-exclusive license in the ordinary course of business;

(xvii) any Contract to which a Governmental Entity is a party involving payments to or from the Company in excess of \$1,000,000 in the twelve (12)-month period prior to the date hereof;

(xviii) any Contract that contains any provision pursuant to which the Company is obligated to indemnify or make any indemnification payments to any Person, other than with respect to (A) standard terms and conditions of Contracts entered into in the Ordinary Course of Business or pursuant to the Company's Growth Plan, or non-disclosure agreements and (B) Contracts for the acquisition of all of the capital stock of, or all or substantially all of the assets of, any third party;

(xix) any Contract containing change in control provisions that would reasonably be expected to involve aggregate payments by the Company in excess of (or a loss of revenues with an aggregate value in excess of) \$100,000 in connection with the consummation of the Contemplated Transactions;

(xx) any Contract involving any resolution or settlement of any actual or threatened proceeding, suit (whether civil, criminal, judicial, investigative or administrative), claim, action, litigation, mediation, hearing, audit, criminal prosecution, arbitration or other proceeding (including any civil, criminal, administrative, investigative or appellate proceeding) (a "Proceeding") which the Company reasonably expects could involve payments after the date hereof in excess of \$500,000 individually or \$1,000,000 in the aggregate, or that currently provides, or the Company reasonably expects could provide, for any material injunctive or other non-monetary relief; and

(xxi) any Contract concerning the lease or acquisition of aircraft or engines attached thereto.

Each Contract of the type described in this Section 2.12(a) is referred to herein as a "Material Contract". Accurate and complete copies of each Material Contract, including all amendments thereto (or an accurate and complete summary of any oral Material Contract), have been Made Available by Seller to Buyer.

(b) Except as would not reasonably be expected to be material to the Company or the operation of the Business, (i) each Material Contract is a valid and binding obligation of the Company and, to the Knowledge of the Company, of the other party or parties thereto, in accordance with its terms, and is in full force and effect except that (A) such enforcement may be subject to applicable bankruptcy, insolvency or other similar laws, now or hereafter in effect, affecting creditors' rights generally and (B) the remedy of specific performance and injunctive and other forms of equitable relief may be subject to equitable defenses and to the discretion of the court before which any Proceeding therefor may be brought; (ii) since January 1, 2016, the Company has in all material respects performed all obligations required to be performed by it under each Material Contract and, to the Knowledge of the Company, each other party to each Material Contract has in all material respects performed all obligations required to be performed by it under such Material Contract; and (iii) since January 1, 2016, neither the Company, nor to the Knowledge of the Company, any other party to a Material Contract, has violated any provision of, or taken or failed to take any act which, with or without notice, lapse of time, or both, would constitute a default under the provisions of such Material Contract, and (iv) since January 1, 2016, the Company has not received written notice that it has breached, violated or defaulted under any Material Contract.

### 2.13 Litigation.

(a) (i) There is no Proceeding pending or, to the Knowledge of Seller, threatened against, Seller that challenges the validity or propriety of, or seeks to prevent, restrain, prohibit, materially impair or materially delay the execution and delivery by Seller of this Agreement or any other Transaction Document to which Seller is a party or the consummation of the Contemplated Transactions and (ii) Seller is not subject to any outstanding judgment, order or decree which would reasonably be expected to have a material adverse effect on the ability of Seller to consummate the Contemplated Transactions.

(b) There is no, and since January 1, 2015, there has not been any Proceeding pending or, to the Knowledge of the Company, threatened against, the Company or its business, properties or assets: (i) that seeks or alleges monetary damages in excess of \$250,000 individually or \$500,000 in the aggregate for related claims, or that would otherwise reasonably be expected to be material to the Company, (ii) that seeks any form of non-monetary remedies that, if granted, would reasonably be expected to be material to the Company, (iii) that could prohibit the Company or any of its officers or other employees from engaging in, or continuing any conduct, activity or practice relating to the Business or (iv) that challenges the validity or propriety of, or seeks to prevent, materially impair or materially delay consummation of this Agreement or the Contemplated Transactions.

(c) The Company has not failed to pay any settlement Contract and is not subject to any outstanding order, writ, decision, award, ruling, stipulation, assessment, injunction, judgment, settlement agreements, decree, ruling, determination or similar requirement of, or entered, enacted, adopted, promulgated or applied by, with or under the supervision of, any Governmental Entity (each, an "Order") that, is unsatisfied or outstanding, or that, individually or in the aggregate, has had or would reasonably be expected to be material to the Company or would prevent or materially impair or materially delay the performance by Seller of any of its material obligations under this Agreement.

### 2.14 Environmental Matters.

(a) Since January 1, 2012, the Company has been and currently is in compliance in all material respects with all applicable Environmental Laws, and has obtained, or has made timely and complete application for renewal of, and is in compliance in all material respects with, all Environmental Permits necessary for the conduct and operation of the Business as now being conducted.

(b) There is not now, and since January 1, 2012, there have not been, any Hazardous Substances generated, treated, stored, transported, disposed of, Released, or otherwise existing on, under, about, or emanating from or to, any property currently owned, leased or operated by the Company, or any property previously owned, leased or operated by the Company at the time the Company owned, leased or operated said property, in each case including areas at airports where Aircraft are or were fueled, except in material compliance with any applicable Environmental Laws, and except as would not result in material liability to the Company under Environmental Laws.

(c) Except as set forth in Section 2.14(c) of the Seller Disclosure Schedule, since January 1, 2012, the Company has not received any notice of alleged liability for, or any inquiry or investigation regarding, any Release or threatened Release of Hazardous Substances or alleged violation of, or non-compliance with, any Environmental Law, except as would not result in material liability to the Company.

(d) The Company has Made Available to Buyer true, correct and complete copies of any material environmental reports, studies, assessments, and other material information in its possession relating to the Company and its current or former properties or operations as each relates to environmental matters or Hazardous Substances.

## 2.15 Intellectual Property.

(a) Section 2.15(a) of the Seller Disclosure Schedule sets forth a list of the following Intellectual Property Rights that are (i) registered or for which an application for registration is currently pending with a Governmental Entity or domain name registrar and that are owned by the Company (excluding any URL and Internet domain name registrations that are not material to the marketing and promotion of the Company or that are not currently in use or are only in short-term use by the Company) (the "Registered Intellectual Property") or (ii) unregistered and material to the Business, including: (i) for each patent and patent application, the patent number or application serial number for each jurisdiction in which the patent or application has been filed, the respective jurisdiction where filed, the date filed or issued, and the present status thereof; (ii) for each trademark, trade name or service mark that is registered, for which a pending application for registration has been filed, the application serial number or registration number, the jurisdiction where filed, the date filed or granted, and the class of goods covered, in each case, if applicable; and (iii) for any Internet domain names (excluding any URL and Internet domain name registrations that are not material to the marketing and promotion of the Business or that are not currently in use or are only in short-term use by the Company), the registration date, any renewal date and name of the Internet domain name registrar.

(b) The Company exclusively owns the Registered Intellectual Property and all other material Intellectual Property Rights owned by the Company (collectively, "Owned Intellectual Property"), free and clear of Liens (other than Permitted Liens). The Registered Intellectual Property owned by the Company is subsisting, and to the Knowledge of the Company, the Registered Intellectual Property (excluding any pending applications included in the Registered Intellectual Property) is valid and enforceable and has not expired or been cancelled, abandoned or otherwise terminated, and payment of all renewal and maintenance fees and expenses in respect thereof, and all filings related thereto, have been duly made.

(c) The Company owns or has valid and sufficient rights to use, pursuant to a valid written Contract (the "Licensed Intellectual Property"), all Intellectual Property Rights that are material to the Business as currently conducted (collectively referred to herein as the "Material Intellectual Property"); *provided*, that the foregoing shall not be deemed a representation or warranty of non-infringement of Third Party Intellectual Property Rights. The Company has used commercially reasonable efforts to maintain and protect each item of Material Intellectual Property.



(d) No Proceedings are pending, or, to the Knowledge of the Company, are threatened against, the Company, that challenge the Company's ownership of the Owned Intellectual Property and, to the Knowledge of the Company, no Proceeding, including any interference, opposition, reissue, reexamination, derivation, post-grant or other similar Proceeding, is pending or threatened, in which the scope, validity or enforceability of any of the Registered Intellectual Property is being or has been contested or challenged.

(e) The conduct of the Business by the Company and the use of the Owned Intellectual Property does not, infringe upon, misappropriate or otherwise violate any valid and enforceable Intellectual Property Rights of any third party in any material respect, and since January 1, 2015, there have been no claims of such infringement, misappropriation or other violation that have been threatened in writing against the Company that have not been settled or withdrawn prior to the date of this Agreement and, to the Knowledge of the Company, there is no existing fact or circumstance that would be reasonably expected to give rise to any such Proceeding. To the Knowledge of the Company, no Person is infringing or otherwise violating any Owned Intellectual Property or any rights of the Company in any Licensed Intellectual Property in any material respect.

(f) To the Knowledge of the Company, all Software material to the Business (i) performs in material conformance with its documentation, (ii) is free from any material Software defect, and (iii) does not contain any virus, software routine or hardware component designed to permit unauthorized access or to disable or otherwise harm any computer, systems or Software, or any software routine designed to disable a computer program automatically with the passage of time or under the positive control of a Person other than an authorized licensee or owner of the Software.

(g) The Company has a privacy policy (the "Privacy Policy") regarding the collection and use of personally identifiable information ("Personal Information"), a true, correct and complete copy of which has been provided to Buyer prior to the date hereof. To the Company's Knowledge, the Company is in material compliance with all applicable Laws regarding the collection, use and protection of Personal Information and with the Company's Privacy Policy, and, to the Company's Knowledge, no Person has gained unauthorized access to or made any unauthorized use of any such Personal Information maintained by the Company. To the Company's Knowledge, the Company has reasonable security measures in place to protect Personal Information stored in their computer systems from unlawful use by any third party or any other use by a third party that would violate the Privacy Policy. The execution, delivery or performance of this Agreement by Seller or the Contemplated Transactions do not violate the Privacy Policy as it currently exists and, upon Closing, the Company will own all such Personal Information and continue to have the right to use such Personal Information on identical terms and conditions as the Company enjoyed immediately prior to the Closing. No Proceedings are pending or, to the Knowledge of the Company, threatened against the Company relating to the collection or use of Personal Information.

#### 2.16 Tax Matters.

(a) The Company has filed or caused to be filed all federal income and other material Tax Returns required to have been filed by or with respect to the Company, and all

such Tax Returns are true, complete and accurate in all material respects. Subject to exceptions as would not be material, no claim has been made in the past three years in writing by a Governmental Entity in a jurisdiction where the Company does not file Tax Returns that the Company is or may be subject to Taxes in such jurisdiction.

(b) All material amounts of Taxes of the Company due and payable (whether or not shown on any Tax Return) have been paid except for those Taxes that are being contested in good faith by appropriate proceedings and for which adequate reserves have been set aside by the Company (which proceedings are listed in Section 2.16(b) of the Seller Disclosure Schedule).

(c) The accrual for Taxes (other than any reserve for deferred Taxes established to reflect timing differences between book and Tax accrual) in the Company Financial Statements (as opposed to the notes thereto) is sufficient for the payment of all unpaid Taxes of the Company, whether or not disputed or due and payable prior to the Closing Date, for all periods ending on and prior to the date thereof and, as of the Closing Date, there will be no unpaid Tax liabilities of the Company attributable to Pre-Closing Tax Periods (as determined in accordance with Section 4.6) other than Tax liabilities taken into account in, or specifically excluded from, the calculation of the Purchase Price. Since the date of the Company Interim Financial Statements, the Company has not incurred any liabilities for Taxes other than in the Ordinary Course of Business or sales, excise, use or similar Taxes in connection with actions taken by the Company pursuant to the Company Growth Plan.

(d) No deficiencies for any material amount of Taxes have been proposed or assessed in writing against the Company by any Governmental Entity which remain unpaid or unresolved, except for deficiencies being contested in good faith by appropriate proceedings and for which adequate reserves have been set aside by the Company (which proceedings are listed in Section 2.16(d) of the Seller Disclosure Schedule). The Company (i) is not the subject of any currently ongoing Tax audit or other proceeding with respect to Taxes and (ii) has not waived any statute of limitations in respect of any Taxes or agreed to any extension of time with respect to a Tax assessment or deficiency, which waiver or extension is currently in effect. There are no Liens for Taxes (other than for Taxes not yet due and payable) upon any of the assets of the Company.

(e) The Company is not a party to and has no liability under any written agreement for the sharing, indemnification or allocation of Taxes (other than customary provisions for Taxes contained in credit, lease or other commercial agreements the primary purposes of which do not relate to Taxes) or any advance pricing agreement closing agreement or other similar agreement relating to any Tax with any Taxing Authority with respect to or involving the Company.

(f) The Company has never been a member of any consolidated, combined, affiliated, or aggregate group of companies for any Tax purposes, and has no liability for the Taxes of any Person (other than Taxes of the Company) under Treasury Regulation section 1.1502-6 (or any similar provision of state, local or foreign law), or as a transferee or successor, by Contract or otherwise (other than customary provisions for Taxes contained in credit, lease or other commercial agreements the primary purposes of which do not relate to Taxes).

(g) The Company has withheld and, to the extent required by Law, paid to the appropriate Governmental Entity all material amounts of Taxes required to have been withheld and paid in connection with amounts paid or owing to any employee, independent contractor, creditor, member or other third party, and has complied in all material respects with all Tax information reporting and backup withholding provisions of all applicable Laws related to the foregoing.

(h) The Company has not entered into any “reportable transaction” within the meaning of Treasury Regulation Section 1.6011-4(b).

(i) The Company (i) has no application pending with the IRS requesting permission for any material changes in Tax accounting methods and has not agreed to nor is required to make (including as a result of the transactions contemplated by this Agreement) any adjustments pursuant to Section 481 of the Code or any similar provision of Law and no Taxing Authority has proposed any such adjustment; and (ii) will not be required to include any material item of income in, or exclude any material item of deduction from, taxable income for any taxable period (or portion thereof) ending after the Closing Date under any provision of federal, state, local or foreign Tax law or by agreement with any Taxing Authority as a result of (A) an installment sale or open transaction disposition made prior to the Closing, (B) percentage of completion method of accounting or completed contract method of accounting, (C) any prepaid amount received on or prior to the Closing or (D) an election pursuant to Section 108(i) of the Code made prior to the Closing.

(j) The Company has been treated as an entity disregarded from its owner for federal income tax purposes at all times during its existence.

(k) The Company has not granted to any Person any power of attorney that is currently in force with respect to any Tax matter.

(l) The Company does not have an office or fixed place of business in any country other than the United States except as set forth on Section 2.16(l) of the Seller Disclosure Schedule.

(m) There are no outstanding rulings or requests for rulings with any Taxing Authority addressed, directly or indirectly, to the Company.

(n) The Company has paid all material amounts of Taxes and has complied with any applicable reporting and other Tax Laws, in each case, with respect to the ownership, operation or leasing of aircraft and the operation of an airline, including any fuel, transportation and aviation Taxes.

2.17 Insurance. The Company maintains insurance coverage, or maintains self-insurance practices, in such amounts and covering such risks as are in accordance with customary industry practice for air carriers operating in the United States. Section 2.17 of the Seller Disclosure Schedule sets forth a true and complete list of all material insurance policies

and fidelity bonds and all material self-insurance programs and arrangements relating to the business, equipment, properties, employees, officers or directors, assets and operations of the Company, showing the type of coverage, insurer, effective dates and policy numbers, and with respect to any self-insurance or co-insurance arrangements, the reserves established thereunder (collectively, the “Insurance Policies”). The Company has Made Available to Buyer true, correct and complete copies of each Insurance Policy. Each of the Insurance Policies is listed in Section 2.17 of the Seller Disclosure Schedule and is in full force and effect, all premiums due and payable thereon have been paid when due and the Company is in compliance in all material respects with the terms and conditions of such Insurance Policies. Since January 1, 2015, the Company has not received any written notice regarding any actual or possible invalidation, cancellation or non-renewal of any Insurance Policy that has not been renewed in the ordinary course without any lapse in coverage or written notice of refusal of any coverage or rejection of any material claim under any such Insurance Policy, and to the Knowledge of the Company, no early termination of any Insurance Policy is or has been threatened. With respect to each material Proceeding that has been filed or investigation that has been initiated against the Company since January 1, 2015, no insurance carrier has disputed, questioned or issued a denial of coverage with respect to any such material Proceeding or investigation, or informed any of the Company of its intent to do so.

2.18 Properties and Assets. The Company has good and valid title to, or has a valid leasehold interest in, or a valid right under Contract to use, all of the material tangible personal property (a) reflected in the latest balance sheet of the Company prior to the date hereof as being owned by the Company or acquired after the date thereof (except tangible personal properties sold or otherwise disposed of since the date thereof in the Ordinary Course of Business), including property acquired pursuant to the Company Growth Plan, or otherwise purported to be owned by the Company, (b) that is used or exploited in the Business or that is necessary to enable the Company to conduct the Business in the Ordinary Course of Business, in each case free and clear of all Liens, other than Permitted Liens. The material tangible personal property of the Company is in good operating condition and repair for its continued use as it has been used in all material respects, subject to reasonable wear and tear. The assets, properties, services and rights of the Company constitute all of the assets, properties, services and rights necessary and sufficient to conduct of the Business in all material respects from and after the Closing Date without interruption and in substantially the same manner as it has been conducted by the Company as of the date hereof and as of the Closing Date.

2.19 Real Property.

(a) Section 2.19(a) of the Seller Disclosure Schedule sets forth all leases or subleases and any amendments, guaranties or other agreements related thereto (collectively, the “Real Property Leases”) pursuant to which all real property for which the leased premises exceeds 2,500 square feet is leased, subleased, used or occupied by the Company (collectively, the “Leased Real Property”). The Company has a valid and subsisting leasehold interest in all Leased Real Property leased by them, in each case free and clear of all Liens, other than Permitted Liens. Seller has provided Buyer with a true and complete copy of all Real Property Leases.

(b) The Company does not own any real property, nor is it a party to any Contract or otherwise has any obligation to acquire any real property.

(c) The Company has not received written notice of any Proceedings in eminent domain, condemnation or other similar Proceedings that are pending, and, to the Knowledge of the Company, there are no such Proceedings threatened, affecting any portion of the Leased Real Property.

(d) The Company has a valid leasehold estate in all Leased Real Property, in each case free and clear of all Liens, other than Permitted Liens. Except as set forth in Section 2.19(d) of the Seller Disclosure Schedule, no Leased Real Property is subject to any lease, license or sublease or any use and occupancy agreement pursuant to which the Company has granted any third party the right to use or occupy all or any portion of the Leased Real Property greater than 10% of the leased premises.

2.20 Affiliate Transactions. Except for any employment-related agreements or as set forth in Section 2.20 of the Seller Disclosure Schedule, no Company Affiliated Person is party to any Contract, arrangement or transaction with or binding upon the Company or any of its properties or assets (including any such Contract involving the making of any payment or transfer of assets to, any Company Affiliated Person). Except as set forth in Section 2.20 of the Seller Disclosure Schedule, no Company Affiliated Person conducts any portion of the Business (other than in a capacity as a director, governor or officer of the Company) or has any interest in any of the assets used in, or necessary to, the business of the Company.

2.21 Brokers. Except for Seller's obligations to Barclays PLC, neither Seller nor any member, director, officer, employee or Affiliate of Seller or the Company, has incurred or will incur on behalf of the Company, any brokerage, finders', financial advisory or similar fee in connection with the Contemplated Transactions.

#### 2.22 Aircraft.

(a) Section 2.22(a)(i) of the Seller Disclosure Schedule sets forth a true and complete list of (i) all aircraft operated under the operating certificate of the Company and (ii) all aircraft and all engines attached thereto owned or leased by the Company, in each case as of the date of this Agreement (collectively, the "Aircraft"), including the manufacturer's model and aircraft number of each such Aircraft. Section 2.22(a)(ii) of the Seller Disclosure Schedule sets forth a true and complete list of all aircraft engines owned or leased by the Company (such engines, the "Spare Engines").

(b) All Aircraft are properly registered on the FAA aircraft registry, in airworthy condition and have a validly issued FAA certificate of airworthiness that is in full force and effect (except for the period of time any aircraft may be out of service and such certificate is suspended in connection therewith).

(c) All Aircraft and Spare Engines are being maintained in all material respects according to applicable FAA regulatory standards and FAA-approved maintenance programs of the Company. The Company has implemented maintenance schedules with respect to Aircraft and engines that, if complied with, are designed to result in the satisfaction of all

requirements under all applicable airworthiness directives and Aviation Regulations required to be complied with in accordance with the FAA-approved maintenance program of the Company, and the Company is in compliance with such maintenance schedules in all material respects.

(d) Section 2.22(d) of the Seller Disclosure Schedule sets forth a true and complete list, as of the date of this Agreement, of all Contracts (other than Contracts that may be terminated or cancelled by the Company without incurring any material penalty) pursuant to which the Company has a binding obligation to lease aircraft, engines or simulators.

2.23 Company Slots and Operating Rights. Section 2.23 of the Seller Disclosure Schedule sets forth a true and complete list of all takeoff and landing slots, operating authorizations from the FAA or any other Governmental Entity and other similar designated takeoff and landing rights held by the Company (the "Company Slots") at any domestic airport (except for seasonal swaps and temporary returns to the FAA, in each case, with a duration of approximately six months or less). None of the Company Slots have been leased from another air carrier or are slots or authorizations in which the Company holds only temporary use rights (except for seasonal swaps and temporary returns to the FAA, in each case, with a duration of approximately six months or less). The Company has complied in all material respects and is in compliance in all material respects with all regulations of the FAA and each other Governmental Entity with respect to the Company Slots. The Company has not (a) received any written notice of any proposed withdrawal of the Company Slots by the FAA or any other Governmental Entity or (b) agreed to any future slide, trade (except for seasonal swaps and temporary returns to the FAA, in each case, with a duration of approximately six months or less), purchase, sale, exchange, lease, or transfer (except for seasonal swaps and temporary returns to the FAA, in each case, with a duration of approximately six months or less) of any of the Company Slots that has not been consummated. The Company Slots have not been designated for the provision of essential air service under the regulations of the FAA, were not acquired pursuant to 14 C.F.R. Section 93.219, and have not been designated for international operations, as more fully detailed in 14 C.F.R. Section 93.217. To the extent covered by 14 C.F.R. Section 93.227 or any order, notice, or requirement of the FAA or any other Governmental Entity, the Company has used the Company Slots (or the Company Slots have been used by other operators) either at least 80% of the maximum amount that each Company Slot could have been used during each full reporting period (as described in 14 C.F.R. Section 93.227(i) or any such order, notice or requirement) or such greater or lesser amount of minimum usage as may have been required to protect such Company Slot's authorization from termination or withdrawal under regulations or waivers established by any airport authority or any other Governmental Entity

2.24 Airports. As of the date of this Agreement, no airport authority at any airport at which the Company operates (each such airport, an "Airport") has taken any action, nor, to the Knowledge of the Company, is any such action threatened, that would reasonably be expected to materially interfere with the ability of the Company to conduct its operations at any Airport in substantially the manner as currently conducted.

2.25 U.S. Citizen; Air Carrier. Each of Seller and the Company is a "citizen of the United States" as defined in 49 U.S.C. § 40102(a)(15) of the Federal Aviation Act of 1958 and is an "air carrier" within the meaning of such act operating under certificates issued pursuant to 49 U.S.C. § 41101-41112.

2.26 Charter Customers. Section 2.26 of the Seller Disclosure Schedule sets forth the names of the twenty (20) largest charter customers of the Company (the “Top Charter Customers”) measured by dollar value of revenues to the Company for the twelve (12) calendar months ended June 30, 2017. None of the Top Charter Customers has (a) canceled or threatened to cancel or otherwise terminate its relationship with the Company, (b) decreased or limited materially, or threatened to decrease or limit materially, or, to the Knowledge of the Company, intends to decrease or limit materially, its use of charter services from the Company, (c) notified the Company in writing or, to the Knowledge of the Company, orally that it is materially and adversely modifying its relationship with the Company, or (d) materially changed since June 30, 2017.

2.27 Assets and Sales Outside of the United States. The Company does not (i) own any assets or property located outside of the United States and (ii) did not have annual revenue from sources outside of the United States in excess of \$5,000,000 in the twelve (12) months ended October 31, 2017.

2.28 Limitation on Representations or Warranties. EXCEPT AS EXPRESSLY SET FORTH IN THIS ARTICLE II, SELLER MAKES NO REPRESENTATION OR WARRANTY, EXPRESS OR IMPLIED, AT LAW OR IN EQUITY, IN CONNECTION WITH OR WITH RESPECT TO SELLER OR THE COMPANY, OR THEIR ASSETS, OPERATIONS, PROSPECTS OR FINANCIAL CONDITION, OR WITH RESPECT TO ANY INFORMATION PROVIDED OR MADE AVAILABLE TO BUYER. ALL OTHER REPRESENTATIONS OR WARRANTIES ARE HEREBY DISCLAIMED. WITHOUT LIMITING THE GENERALITY OF THE FOREGOING, SELLER MAKES NO REPRESENTATION OR WARRANTY AS TO THE FUTURE PERFORMANCE, PROFITABILITY OR FINANCIAL RESULTS OF THE COMPANY.

### ARTICLE III

#### REPRESENTATIONS AND WARRANTIES OF BUYER

Except as disclosed in the disclosure schedule (the “Buyer Disclosure Schedule”) delivered by Buyer to Seller prior to execution of this Agreement (which sets forth items of disclosure; it being understood that matters disclosed pursuant to one section of the Buyer Disclosure Schedule shall be deemed to be disclosed with respect to other sections where it is reasonably apparent on the face of the disclosure (without reference to any extrinsic document), that the matters so disclosed are also applicable to such other sections), Buyer Parties represent and warrant to Seller, as of the date hereof and as of the Closing Date, as follows:

3.1 Organization and Authority. Buyer is a limited liability company, duly organized, validly existing and in good standing under the Laws of the State of Delaware. Parent is a limited liability company, duly organized, validly existing and in good standing under the Laws of the State of Delaware. Each of the Buyer Parties has all requisite power and authority, to enter into this Agreement and each of the other Transaction Documents to which it is a party, to carry out its obligations hereunder and thereunder, and to consummate the Contemplated Transactions. The execution by each of the Buyer Parties of this Agreement and each of the other Transaction Documents to which it is a party and the consummation of the Contemplated

Transactions have been duly and validly authorized by all required limited liability company action on the part of each Buyer Party, and no other proceedings on the part of either Buyer Party are required to authorize this Agreement or any of the other Transaction Documents to which it is a party or the consummation of the Contemplated Transactions. This Agreement and each of the other Transaction Documents to which each Buyer Party is a party has been duly and validly executed and delivered by Seller and, assuming due authorization, execution and delivery by Seller, constitutes the valid and binding obligation of each Buyer Party, as applicable, enforceable against such Buyer Party in accordance with its terms, except that (i) such enforcement may be subject to applicable bankruptcy, insolvency or other similar Laws, now or hereafter in effect, affecting creditors' rights generally and (ii) the remedy of specific performance and injunctive and other forms of equitable relief may be subject to equitable defenses and to the discretion of the court before which any proceeding therefor may be brought.

**3.2 No Conflict.** None of the execution, delivery or performance of the applicable Transaction Documents by Buyer Parties, the consummation by Buyer Parties of the Contemplated Transactions, or compliance by Buyer Parties with any of the provisions of this Agreement will (with or without notice or lapse of time, or both): (a) conflict with or violate any provision of the certificate of incorporation or by-laws or similar organizational and governing documents of Buyer or Parent; (b) assuming that all consents, approvals, authorizations and permits described in Section 3.3 have been obtained and all filings and notifications described in Section 3.3 have been made and any waiting periods thereunder have terminated or expired, (i) conflict with or violate any Law applicable to Buyer Parties or any of their respective properties or assets; or (ii) require any consent or approval under, violate, conflict with, result in any breach of or any loss of any benefit under, or constitute a default (or an event which with notice or lapse of time or both would become a default), or result in termination of or accelerate the performance required by, or give to others any right of termination, amendment, acceleration, purchase, sale, modification or cancellation under any Contract binding on the Buyer Parties or (c) result in the creation of a Lien, other than Permitted Liens, upon any of the respective properties or assets of Buyer or Parent pursuant to, any Contract, to which Buyer or Parent is a party, except, with respect to clauses (b) and (c), for any such conflicts, violations, consents, breaches, losses, defaults, other occurrences or Liens which, individually or in the aggregate, would not reasonably be expected to have a Buyer Material Adverse Effect.

**3.3 Required Filings and Consents.** None of the execution, delivery or performance of this Agreement or any other Transaction Document by Buyer Parties, the consummation by Buyer or Parent of the Contemplated Transactions, or compliance by Buyer or Parent with any of the provisions of any Transaction Document will require (with or without notice or lapse of time, or both) any consent, approval, authorization or permit of, or filing or registration with or notification to, any Governmental Entity, other than (a) compliance with any applicable requirements of the HSR Act, (b) compliance with the applicable requirements of the Exchange Act, (c) any application, filing, notice, report, registration, approval, permit, authorization, consent or submission required to be made or obtained under Title 49 of the United States Code or under any regulation, rule, order, notice or policy of the FAA, the DOT, the FCC and the DHS, including the TSA, (d) compliance with the applicable requirements of the Securities Act, (e) compliance with any applicable foreign or state securities or Blue Sky Laws, (f) filings with the SEC as may be required by Buyer or Parent in connection with this Agreement and the transactions contemplated hereby, and (g) such filings as may be required under the rules and regulations of any securities exchange.



### 3.4 Litigation.

(a) There is no Proceeding pending or, to the Knowledge of Buyer Parties, threatened against Buyer or Parent that, individually or in the aggregate, would reasonably be expected to have a Buyer Material Adverse Effect or challenges the validity or propriety of, or seeks to prevent, restrain, prohibit, materially impair or materially delay the execution and delivery by Buyer of this Agreement or any other Transaction Document to which Buyer is a party or the consummation of the Contemplated Transactions.

(b) Neither Buyer nor Parent is subject to any outstanding Order that, individually or in the aggregate, has had or would reasonably be expected to have a Buyer Material Adverse Effect.

3.5 Financial Capability. Buyer Parties have available to them, or as of the Effective Time will have available to them, sufficient cash, available lines or credit or other sources of immediately available and committed financing necessary to consummate the Contemplated Transactions and to satisfy all of their obligations under this Agreement, including the payment of the Purchase Price in accordance with Section 1.3 hereof, and payment of all costs, fees and expenses in connection herewith.

3.6 Management Arrangements. As of the date hereof, none of Buyer, Parent or their executive officers, directors or Affiliates, has entered into any agreement, arrangement or understanding with any of the executive officers or directors of the Company that is currently in effect or would become effective in the future (upon the consummation of the transaction contemplated herein or otherwise).

3.7 Citizen; Air Carrier. Buyer and Parent are each a “citizen of the United States” as defined in 49 U.S.C. § 40102(a)(15). If Buyer or Parent is an “air carrier” within the meaning of the Federal Aviation Act of 1958, it is operating under certificates issued pursuant to 49 U.S.C. § 41101-41112.

3.8 Labor Agreements. Buyer Parties acknowledge that (a) they have reviewed the Company’s labor agreements described in Section 2.11(b) of the Seller Disclosure Schedule, and (b) the Company will continue to be bound by such agreements according to the terms set forth therein, and the provisions of the Railway Labor Act, 45 U.S.C. §§ 151 et seq., immediately following the Closing.

3.9 Brokers. None of Buyer, Parent, nor any of their stockholders, directors, officers, employees or Affiliates, has incurred or will incur on behalf of Buyer or Parent, any brokerage, finders’, financial advisory or similar fee in connection with the transactions contemplated by this Agreement.

3.10 No Other Representations or Warranties. Except for the representations and warranties contained in Article II, Buyer acknowledges that none of Seller, the Company or any Representatives of Seller or the Company or any of their respective Affiliates makes, and

Buyer acknowledges that it has not relied upon or otherwise been induced by, any other express or implied representation or warranty by or on behalf of Seller or the Company or with respect to any other information provided or Made Available to Buyer by or on behalf of Seller or the Company in connection with the transactions contemplated by this Agreement, including any information, documents, projections, forecasts or other material provided or Made Available to Buyer or its Representatives in certain “data rooms” or management presentations in expectation of the transactions contemplated by this Agreement.

## ARTICLE IV

### COVENANTS

#### 4.1 Covenants of Seller.

(a) Ordinary Course of Business. Except as expressly provided or permitted herein, or as consented to in writing by Buyer (such consent not to be unreasonably withheld), during the period commencing on the date of this Agreement and ending at the Closing Date or such earlier date as this Agreement may be terminated in accordance with its terms (the “Pre-Closing Period”), Seller shall, and covenants and agrees to cause the Company to (as applicable) act and carry on its business in the Ordinary Course of Business and the Company Growth Plan, including, using commercially reasonable efforts (which efforts specifically do not include making payments to employees, customers, vendors or other parties outside the Ordinary Course of Business) to (A) preserve intact in all material respects its business organization and reputation, (B) maintain its assets and properties in good working order and condition, ordinary wear and tear excepted, maintain in effect all of its material Permits, (D) maintain its existing relationships and goodwill with Governmental Entities, suppliers, vendors, creditors, employees, customers and agents, (E) keep available the services of its directors, governors, officers and key employees, (F) manage its working capital (including timing of collection of accounts receivable and of the payment of accounts payable) in the Ordinary Course of Business and (G) make all budgeted capital expenditures in the Ordinary Course of Business, in each case, other than as expressly described in the Company Growth Plan.

(b) Specific Actions. Without limiting the generality of the foregoing, except as expressly provided or permitted herein or undertaken according to the process described in the Company Growth Plan, during the Pre-Closing Period, Seller covenants and agrees that it shall not cause or permit the Company to, directly or indirectly, do any of the following without the prior written consent of Buyer:

(i) amend the Company Organizational Documents or the terms of the Units;

(ii) issue, deliver, authorize, create, sell, grant, pledge or otherwise dispose of or encumber, propose or take any action in furtherance of the foregoing, any Equity Interests of the Company or any securities convertible into or exchangeable for, or any rights, conversion privileges, warrants, options or other rights of any kind to acquire or receive payment in respect of the value of, Equity Interests of the Company;

(iii) declare, set aside or pay any dividend or other distribution in respect of Equity Interests of the Company (whether by merger, consolidation or otherwise) or redeem, purchase or otherwise acquire any outstanding Equity Interests of the Company; *provided*, that the foregoing shall not restrict the Company from declaring or paying any cash dividend or distribution that is paid in full prior to the Closing Date;

(iv) except as described in clause (ix) below, sell, lease, license, pledge, transfer or otherwise dispose of or encumber any material properties or material assets of the Company or subject any of such assets or properties to any Liens (other than Permitted Liens), other than in the Ordinary Course of Business or properties or assets with a fair market value of less than \$500,000;

(v) except as set forth on Section 4.1(b)(v) of the Seller Disclosure Schedule or as otherwise described in the Company Growth Plan, (A) amend, modify, supplement in any material respect, enter into, become subject to, grant any waiver of any material term under, give any material consent with respect to, or terminate any Material Contract other than other than (i) bidding for, entering into, renewing or replacing Contracts with customers or vendors in the Ordinary Course of Business that (A) provide for aggregate annual payments by or to the Company of less than \$1,000,000 or (B) have a term of less than twenty-four (24) months and are capable of being terminated on sixty (60) days' notice or less and (ii) terminations of Contracts as a result of the expiration of the term of such Contracts or (B) enter into any Contract that would require a payment to or give rise to any rights to such other party or parties in connection with the Contemplated Transactions to the extent such payment would not constitute an Unpaid Transaction Expense.

(vi) create, incur, assume, suffer to exist or otherwise be liable with respect to any Indebtedness, other than the incurrence of trade indebtedness in the Ordinary Course of Business;

(vii) make any loans, advances or capital contributions to, or investment in, any other Person;

(viii) sell, assign, transfer, lease, license or allow to lapse any rights in the Material Intellectual Property;

(ix) except for aircraft purchases and improvements or reconfigurations as set forth in the Company Growth Plan or expenditures for emergency or other repairs in connection with restoring an aircraft into service, make any capital expenditures with respect to property, plant or equipment of the Company in excess of \$250,000 per occurrence;

(x) make any changes in accounting methods, principles or practices, except insofar as may be required by a change in GAAP as agreed to by its independent public accountants;

(xi) redeem, purchase or acquire or offer to acquire any, shares of common stock or other securities of any third party;

(xii) enter into, modify or amend (except termination in accordance with Section 4.13), any transaction or Contract with, any Company Affiliated Person;

(xiii) make or change any income Tax or other material election in respect of Taxes, adopt or change any accounting method in respect of Taxes, file any amendment to an income Tax Return or other material Tax Return, settle any claim or assessment in respect of Taxes or surrender any refund in respect of Taxes or consent to any extension or waiver of the limitation period applicable to any claim or assessment in respect of Taxes, enter into a closing agreement in respect of Taxes, request a ruling related to Taxes, fail to duly and timely file all income Tax and other material Tax Returns and other documents required to be filed with any Taxing Authority in accordance with past practice (taking into account any extension of time within which to file such Tax Return) or incur any liability for Taxes other than in the Ordinary Course of Business;

(xiv) enter into any new contract or agreement that requires payments by or to the Company in excess of \$250,000 per year other than in the Ordinary Course of Business;

(xv) commence, pay, discharge, settle or satisfy any Proceedings, liabilities or obligations (absolute, accrued, asserted or unasserted, contingent or otherwise) in excess of \$500,000, other than the payment, discharge or satisfaction in the Ordinary Course of Business of liabilities reflected or reserved against in the Company Financial Statements or incurred in the Ordinary Course of Business, or waive any material benefits of any confidentiality, standstill or similar agreements to which the Company is a party;

(xvi) fail to continue, in respect of all Aircraft, all maintenance programs consistent with past practice (either with current service providers or other reputable service providers), including using commercially reasonable efforts to keep all such Aircraft in such condition as may be necessary to enable the Company as of the date of this Agreement, other than changes in the Ordinary Course of Business;

(xvii) fail to maintain insurance at levels comparable to current levels or otherwise in a manner inconsistent with past practice;

(xviii) acquire (by merger, exchange, consolidation, acquisition of stock or assets or otherwise) any Person or division or material assets thereof;

(xix) except as specifically described in Section 4.1(b)(xix) of the Seller Disclosure Schedule or as required by applicable Law, (A) grant or provide any change-in-control, retention, equity or equity-based, severance or termination compensation or benefits to any current or former service provider, (B) increase, or accelerate the vesting, payment or funding of, compensation or benefits payable to any current or former service provider, or establish, adopt, amend, renew, announce, waive any rights with respect to, modify or terminate (or commit to do any of the preceding in respect of) any Company Benefit Plan, (C) hire or engage any employee or independent contractor with base compensation in excess of \$150,000 per year, or (D) adopt, enter into, amend, modify, renew or terminate any collective bargaining agreement or any other agreement, arrangement or plan with a union, works council or other employee representative body;

(xx) take any action that would cause the Company to fail to be, or fail to be owned and controlled by, a “Citizen of the United States” as defined in 49 U.S.C. § 40102(a)(15) or an “air carrier” as defined in 49 U.S.C. § 40102(a)(2)(15), or fail to hold an operating certificate issued pursuant to 49 U.S.C. § 41101-41102;

(xxi) purchase, sell or enter into an agreement to purchase or sell any interest in real property;

(xxii) amend or waive any material right under any Real Property Lease, enter into any lease of real property or terminate any Real Property Lease (other than any termination in accordance with the terms of such Real Property Lease);

(xxiii) the lease, purchase or financing of any aircraft or engines other than the purchase or lease of up to seven (7) Boeing 737-800 aircraft on terms substantially consistent with the letters of intent dated October 6, 2017, October 11, 2017 and November 24, 2017 and Made Available to Buyer;

(xxiv) authorize any of or commit or agree, in writing or otherwise, to take any of, the foregoing actions.

(c) Seller covenants and agrees to take such actions as may be necessary to ensure that the Company: notifies Buyer promptly of (A) any material emergency regarding the Company, (B) any change outside of the Ordinary Course of Business or in the operation of the properties of the Company which reasonably could be expected to result in a Material Adverse Effect, and (C) any investigations or hearings (or communications indicating that the same may be contemplated) of any Governmental Entity regarding the Company which reasonably could be expected to result in a Material Adverse Effect.

#### 4.2 No Shop. During the Pre-Closing Period:

(a) From and after the date of this Agreement, Seller shall not, and Seller’s and the Company’s Affiliates, directors, officers, members, governors, employees, investment bankers, attorneys, accountants and other advisors or representatives (directors, officers, members, governors, employees, investment bankers, attorneys, accountants, other advisors and representatives, collectively, the “Representatives”) not to, directly or indirectly:

(i) solicit, initiate or knowingly encourage any inquiries or the making of any proposal or offer that constitutes, or would reasonably be expected to lead to, (A) any proposal or offer for a merger, consolidation, dissolution or sale of assets of the Company having 10% or more of the fair market value of all such assets, (B) any equity purchase, recapitalization, equity exchange or other business combination involving the Company, (C) any proposal for the issuance by the Company of its equity securities or (D) any proposal or offer to acquire in any manner, directly or indirectly, any of the equity securities or consolidated total assets of the Company other than the transactions contemplated by this Agreement (each, an “Acquisition Proposal”);

(ii) enter into, continue or otherwise participate in any discussions or negotiations regarding, or furnish to any Person other than Buyer or its Affiliates or Representatives any non-public information for the purpose of encouraging or facilitating, any Acquisition Proposal or any agreement relating to any Acquisition Proposal; or

(iii) permit any Person other than (i) Seller or its Affiliate or Representatives or (ii) Buyer or its Affiliates or Representatives to access the data room on "Intralinks" or any other "data room" of the Company.

(b) Seller shall, and shall direct its Representatives to, cease immediately all discussions and negotiations that commenced prior to the date of this Agreement regarding any proposal that constitutes, or would reasonably be expected to lead to, an Acquisition Proposal.

(c) Seller shall promptly inform its Representatives of the obligations of Seller under this Section 4.2.

4.3 Notification of Certain Matters. During the Pre-Closing Period, Seller shall, and shall cause the Company to, give prompt notice to Buyer, of:

(a) any material communication from any union, employee or supplier;

(b) any breach of any Material Contract or consent requirement;

(c) any Order restraining, enjoining or otherwise restricting the consummation of the Contemplated Transactions or any complaint or threatened complaint seeking such an Order or (ii) such party's receiving any notice from any Governmental Entity or any other Person of its intention (x) to institute an investigation into, or institute a Proceeding to restrain, enjoin or otherwise restrict, the consummation of the Contemplated Transactions or (y) to nullify or render ineffective this Agreement or the Contemplated Transactions if consummated; and

(d) by written update to the Seller Disclosure Schedule, any inaccuracy of any representation or warranty made by Seller in this Agreement, either when such representation or warranty was made or thereafter which would result in a Material Adverse Effect. The delivery of any notice pursuant to this Section 4.3(d) shall not cure any breach of any representation or warranty requiring disclosure of such matter prior to the date of this Agreement or otherwise limit or affect the rights of, or the remedies available to, Buyer; *provided, however*, that Seller shall be entitled to update the Seller Disclosure Schedule for Contracts required to be disclosed pursuant to Section 2.12 that are entered into between the date hereof and the Closing Date, to the extent such Contracts are entered into in accordance with Section 4.1(b), and the Seller Disclosure Schedule shall be deemed to be amended by any such updates as of the Closing Date.

#### 4.4 Filings and Authorizations; Consummations.

(a) Buyer and Seller shall make, as promptly as reasonably practicable (and in any event within five (5) Business Days of the date of this Agreement (unless counsel to the parties have previously agreed to extend such five (5) Business Day period)), an appropriate filing of a Notification and Report Form pursuant to the HSR Act with respect to the Contemplated Transactions. Each of Seller and Buyer shall, and Seller shall cause the Company to, use commercially reasonable efforts to supply as promptly as practicable any additional information and documentary material that may be reasonably requested pursuant to the foregoing, and use commercially reasonable efforts to take all other actions necessary to cause the expiration or termination of (and not to extend) the applicable waiting periods regarding the foregoing as soon as reasonably practicable. Buyer and Seller acknowledge and agree that they shall split the cost of all filing fees and other charges in connection with the filing under the HSR Act pursuant to this Section 4.4(a).

(b) Each of the parties hereto shall (i) as promptly as practicable after the date hereof, make, or cause to be made, all other filings, notifications, reports, applications and submissions under Law applicable to it or to its Subsidiaries and Affiliates or under any Contract listed on Sections 2.4(b) and 2.5(c) of the Seller Disclosure Schedules, in connection with the Contemplated Transactions; *provided*, that Seller shall cause the Company to make the notice filing with the DOT regarding a substantial change in operations, ownership or management under 14 CFR 204.5 no later than five (5) Business Days following the date upon which the Company receives from Buyer the information concerning Buyer or its Affiliates that is required under 14 CFR 204.5 to prepare such filing (which Buyer shall prepare and provide to Seller within ten (10) Business Days of the date of this Agreement), and (ii) use its respective commercially reasonable efforts to obtain, or cause to be obtained, all other authorizations, approvals, Orders, consents and waivers from all Persons and Governmental Entities necessary to be obtained by it, or its Subsidiaries or Affiliates, in order for it to consummate the Contemplated Transactions.

(c) The parties hereto shall coordinate and cooperate with one another in exchanging and providing such information to each other and in making the filings, notifications, reports, applications and submissions referred to in paragraphs (a) and (b) above (each, a "Filing"); *provided* that, in connection with any Filing made by Buyer or Seller, the other party, to the extent permitted by applicable Law, (i) prior to any proposed Filing, (x) to receive copies of such proposed Filing, and (y) to propose changes to the contents of any such proposed Filing, which shall be considered by the other party in good faith, and (ii) to be informed of and have the right to attend and participate in any meeting, appearance, presentation, argument or any other related in-person event before a Governmental Entity concerning a Filing. The parties hereto shall supply such reasonable assistance as may be reasonably requested by any other party hereto in connection with the foregoing. To the extent that any information or documentation to be provided by either party hereto to the other pursuant to this Section 4.4 is competitively sensitive, such information may be provided only to external counsel for Buyer on an external counsel only basis.

(d) Each party hereto shall promptly inform the other parties of any communication from any Governmental Entity regarding any of the Contemplated Transactions.

If any party or any Affiliate thereof receives a request for additional information or documentary material from any such Governmental Entity with respect to the Contemplated Transactions, then such party will endeavor in good faith to make, or cause to be made, as soon as reasonably practicable and after consultation with the other party, an appropriate response (which shall be deemed a Filing) in compliance with such request, subject in each case to the rights of the other party under Section 4.4(c). In accordance with Seller's rights under Section 4.4(c), Buyer will advise Seller promptly in respect of any understandings, undertakings or agreements (oral or written) (each of which shall be deemed a Filing) which Buyer proposes to make or enter into with any Governmental Entity in connection with the Contemplated Transactions.

(e) The parties hereto shall use commercially reasonable efforts to coordinate and cooperate with one another in exchanging and providing such information to each other, scheduling meetings and communicating with relevant lessors and other third parties, and promptly taking all other necessary action to obtain the consents listed on Section 5.2(f) of the Seller Disclosure Schedule; *provided* that nothing in this Section 4.4(e) shall require a party hereto to (i) grant or offer to grant any accommodation or concession (financial or otherwise), or make any payment, to any third party in connection with seeking or obtaining such consents and (ii) provide any document or information to the extent that (x) it may not be disclosed pursuant to any Law to which the disclosure party is subject or the terms of a non-disclosure agreement with a third party or (y) the disclosure would cause disclosure party to waive its attorney-client privilege, the work product doctrine or any similar privilege with respect to such information, *provided, however*, that the parties will use commercially reasonable efforts to provide privileged information in a manner that would not waive privilege, including entry into a joint defense agreement.

#### 4.5 Access to Information; Confidential Information.

(a) During the Pre-Closing Period and subject to applicable Laws and this Section 4.5, Seller shall, and shall cause the Company to give Buyer and its authorized Representatives reasonable access during normal business hours to all books, records, offices and other facilities and properties of the Company as Buyer and its authorized Representatives may from time to time reasonably request; *provided* that Seller and the Company may withhold any document (or portions thereof) or information to the extent that (x) it may not be disclosed pursuant to any Law to which the Company is subject or the terms of a non-disclosure agreement with a third party or (y) the disclosure would cause the Company to waive its attorney-client privilege, the work product doctrine or any similar privilege with respect to such information, *provided, however*, that Seller will, and cause the Company to, use commercially reasonable efforts to provide privileged information in a manner that would not waive privilege, including entry into a joint defense agreement. Buyer's access to Company's facilities will be coordinated and planned with Seller or Barclays, at mutually convenient times, so as to minimize any disruption to the Company's business.

(b) Buyer Parties acknowledge that in connection with the negotiation of this Agreement and the preparation for the consummation of the transactions contemplated hereby, Buyer Parties will have access to confidential information relating to Seller and the Company. Buyer Parties acknowledge that the information provided to Buyer Parties in connection with this Agreement and the transactions contemplated hereby shall be "Confidential"



Information” (herein referred to as “Confidential Information”) as defined in the nondisclosure agreement between Seller and Apollo Management VIII, L.P., dated as of September 1, 2017 (as amended from time to time, the “Confidentiality Agreement”), and is subject to the terms of the Confidentiality Agreement, and shall be held by Buyer Parties in accordance with and be subject to the terms of the Confidentiality Agreement. Notwithstanding anything to the contrary herein, the terms and provisions of the Confidentiality Agreement shall survive the termination of this Agreement in accordance with the terms therein. In the event of the termination of this Agreement for any reason, Buyer shall comply with the terms and provisions of the Confidentiality Agreement, including returning or destroying all Confidential Information. The Confidentiality Agreement shall terminate at the Closing.

(c) To the extent that any Confidential Information includes materials or other information that may be subject to the attorney-client privilege, work product doctrine or any other applicable privilege or doctrine concerning any Confidential Information or any pending, threatened or prospective Proceeding, investigation, arbitration or dispute, it is acknowledged and agreed that the parties hereto have a commonality of interest with respect to such Confidential Information or Proceeding, investigation, arbitration or dispute and that it is the parties’ mutual desire, intention and understanding that the sharing of such materials and other information is not intended to, and shall not, affect the confidentiality of any of such materials or other information or waive or diminish the continued protection of any of such materials or other information under the attorney-client privilege, work product doctrine or other applicable privilege or doctrine. Accordingly, all Confidential Information that is entitled to protection under the attorney-client privilege, work product doctrine or other applicable privilege or doctrine shall remain entitled to protection thereunder and shall be entitled to protection under the joint defense doctrine, and the parties hereto agree to take all measures necessary to preserve, to the fullest extent possible, the applicability of all such privileges or doctrines.

#### 4.6 Taxes.

(a) Seller shall be responsible for, and shall pay all Taxes of Seller for all periods regardless of when any such Taxes may be payable or assessed and Seller shall be responsible for and shall pay all Taxes with respect to the Company for any taxable periods ending on or before the Closing Date and the portion through the end of the Closing Date for any taxable period that includes (but does not end on) the Closing Date (“Pre-Closing Tax Period”) to the extent such Taxes have not been included as a current Liability for purposes of calculating the Net Working Capital Amount and prepare and file or cause to be filed all Tax Returns for any taxable period that ends on or before the end of the Pre-Closing Tax Period; *provided* that all such Tax Returns shall be prepared on a basis consistent with past practices and Seller shall deliver each such Tax Return to Buyer at least thirty (30) days prior to the date on which such Tax Return is required to be filed with the appropriate Governmental Entity for Buyer’s review and comment; and *provided, further*, that Buyer will cooperate with Seller’s reasonable requests with respect to such Tax Returns, and that Seller shall accept reasonable comments of Buyer.

(b) All transfer, sales, use, value added and other similar Taxes, if any, arising out of the transfer of the Units by Seller to Buyer pursuant to this Agreement shall be borne by one-half (1/2) by Seller and one-half (1/2) by Buyer. The Company will file all necessary Tax Returns and other documentation with respect to all such transfer, sales, use,

value, added and other similar Taxes, and, if reasonably requested by Buyer, Seller will join in the execution of any such Tax Returns and other documentation. Any disagreements with respect to such Tax Returns shall be resolved in accordance with Section 1.4(d)(ii).

(c) In the case of any taxable period that includes (but does not end on) the Closing Date (a “Straddle Period”), (i) the amount of any Taxes of the Company for the Pre-Closing Tax Period that are either (A) based on or measured by income or receipts or (B) imposed in connection with any sale, transfer or assignment or any deemed sale, transfer or assignment of property (real or personal, tangible or intangible) will be determined based on an interim closing of the books as of the effective time of the Closing, and (ii) with respect to Taxes (other than those described in clause (i) above) that are imposed on a periodic basis with respect to the business or assets of the Company or otherwise measured by the level of any item, the amount of Taxes of the Company for a Straddle Period that relates to the Pre-Closing Tax Period will be deemed to be the amount of such Tax for the entire taxable period multiplied by a fraction, the numerator of which is the number of days in the taxable period ending at the effective time of the Closing and the denominator of which is the number of days in such Straddle Period. For purposes of clause (i) of the preceding sentence, any exemption, deduction, credit or other item (including the effect of any graduated rates of Tax) that is calculated on an annual basis shall be allocated to the portion of the Straddle Period ending on the Closing Date on a pro rata basis determined by multiplying the total amount of such item allocated to the Straddle Period times a fraction, the numerator of which is the number of calendar days in the portion of the Straddle Period ending on the Closing Date and the denominator of which is the number of calendar days in the entire Straddle Period. In the case of any Tax based upon or measured by capital (including net worth or long-term debt) or intangibles, any amount thereof required to be allocated under this Section 4.6(c) shall be computed by reference to the level of such items on the Closing Date. The parties hereto will, to the extent permitted by applicable Law, elect with the relevant Taxing Authority to treat a portion of any Straddle Period as a short taxable period ending as of the close of business on the Closing Date.

(d) Seller will be entitled to any refund or credit (to the extent such credit actually reduces a cash Tax liability determined on a with and without basis) with respect to any Tax for which Seller is responsible pursuant to Section 4.6(a) (plus any interest received, by payment or credit, with respect thereto), in each case, net of any reasonable costs or Taxes incurred by Buyer or the Company in connection with obtaining or in connection with the receipt of such refund or credit and excluding any such refund or credit taken into account in the calculation of the Purchase Price or resulting from the utilization of any Tax attribute arising in a post-Closing Tax period. Buyer will pay or cause to be paid to Seller an amount equal to such refund or credit within fifteen (15) Business Days of receipt of such refund or credit. For a period of three (3) years following the Closing Date, Buyer will file (or cause to be filed), at Seller’s sole cost and expense, claims for any refund or credit to which Seller is entitled pursuant to the preceding sentence but only to the extent reasonably requested by Seller and only to the extent Buyer reasonably determines that claiming any such refund or credit is not reasonably expected to be materially detrimental to any post-Closing Tax position of Buyer or the Company (or any direct or indirect owner thereof). In the event any portion of any amount paid pursuant to this Section 4.6(d) shall be required to be repaid by any Governmental Entity, Seller shall be obligated to repay to Buyer the portion of such amount, together with any interest imposed by a Governmental Entity thereon.

#### 4.7 Tax Contests.

(a) If any governmental authority issues to Buyer (A) a notice of its intent to audit or conduct another proceeding with respect to a Tax Return or Taxes of the Company for which Seller is responsible pursuant to Section 4.6(a) or (B) a notice of deficiency with respect to any such Taxes (any such audit, proceeding or deficiency, a “Seller Tax Matter”), Buyer shall promptly notify the Seller of its receipt of such communication from the governmental authority and provide the Seller with copies of all correspondence and other documents received from the Taxing Authority. The Seller, at its sole cost and expense, shall have the right to control (including the selection of counsel) any audit or other proceeding of the Company in respect of a Seller Tax Matter (a “Tax Contest”) other than a Tax Contest relating to a Straddle Period. Buyer shall control any Tax Contest relating to a Straddle Period, *provided, however*, that the Seller, at its sole cost and expense, shall have the right to participate in any Straddle Period Tax Contest for the Company, and Buyer shall not settle, resolve, or abandon a Tax Contest (whether or not the Seller participates in such Tax Contest) relating to a Straddle Period without the prior written permission of the Seller which shall not be unreasonably withheld, delayed, or conditioned.

(b) If the Seller elects to control a Tax Contest (other than a Tax Contest relating to a Straddle Period), (A) the Seller shall notify Buyer of such intent within ten (10) days of receiving notice of the Tax Contest; and (B) while it controls a Tax Contest, the Seller shall (1) keep Buyer reasonably informed regarding the status of such Tax Contest; (2) allow Buyer at Buyer’s sole cost and expense to participate in such Tax Contest; and (3) not settle, resolve, or abandon any such Tax Contest without the prior written consent of the Buyer if such settlement, resolution, or abandonment would result in Buyer incurring any Tax or that could reasonably be expected to have an adverse impact on the Taxes of Buyer or its members.

(c) If the Seller does not elect to control the Tax Contest it may elect to participate in the Tax Contest and if it so elects, (A) the Seller shall notify Buyer of such intent within ten (10) days of receiving notice of the Tax Contest; (B) Buyer shall control such Tax Contest at the Seller’s cost and expense; (C) Buyer shall take actions reasonably necessary to allow the Seller (and its counsel) to fully participate, at the Seller’s sole cost and expense, in such Tax Contest; and (D) Buyer shall not settle, resolve or abandon the Tax Contest without the prior consent of Seller, which consent shall not be unreasonably withheld or delayed.

(d) Seller and Buyer agree to furnish or cause to be furnished to each other, upon request, as promptly as practicable, such information (including access to books and records) and assistance relating to the Company as is reasonably requested for the filing of any Tax Returns and the preparation, prosecution, defense or conduct of any Tax Contest. Seller and Buyer shall reasonably cooperate with each other in the conduct of any Tax Contest or other proceeding involving or otherwise relating to the Company (or its income or assets) with respect to any Tax and each shall execute and deliver such powers of attorney and other documents as are reasonably necessary to carry out the intent of this Section 4.7(d). Any information obtained under this Section 4.7(d) shall be kept confidential, except as may be otherwise necessary in connection with the filing of Tax Returns or in the conduct of a Tax Contest or other Tax proceeding.

**4.8 Public Disclosure.** Except as may be required by Law, (a) no press release announcing the execution of this Agreement or the transactions contemplated hereby shall be issued and if so required to be issued shall only be issued in such form as shall be mutually agreed upon by Seller and Buyer, (b) Buyer and Seller shall consult with the other party before issuing any other press release or otherwise making any public statement with respect to this Agreement, (c) the parties shall make good faith efforts to inform the DOT at least twenty-four (24) hours prior to issuing any other press release or otherwise making any public statements with respect to this Agreement and, (d) each party hereto shall use commercially reasonable efforts to prevent any of its Representatives, and Seller shall prevent the Company and its Representatives, from making any public disclosure or other announcement (whether through press release or publicity materials of any kind) with respect to this Agreement (including, without limitation, any of the terms and conditions hereof) or the transactions contemplated hereby, whether prior to or after any announcement by the parties pursuant to this Section 4.8; *provided*, that notwithstanding the foregoing, Buyer Parties, Apollo Management VIII, L.P. and their respective Affiliates may provide communications regarding the Transaction Documents and the Contemplated Transactions to existing or prospective general and limited partners, equity holders, members, managers and investors of any Affiliates of such Person in the ordinary course of business.

**4.9 Indemnification of Directors and Officers.**

(a) For a period of six (6) years from and after the Closing, Buyer will cause the Company to indemnify and hold harmless all past and present directors and officers of the Company to the same extent such Persons are required to be indemnified as of the date of this Agreement by the Company pursuant to applicable Law, the Company's Organizational Documents and/or indemnification agreements as in effect on the date of this Agreement and Made Available to Buyer with any directors and officers of the Company arising out of acts or omissions in their capacity as directors or officers of the Company occurring at or prior to the Closing. Buyer and the Company will advance expenses (including reasonable legal fees and expenses) incurred in the defense of any Proceedings with respect to the matters subject to indemnification pursuant to this Section 4.9(a) to the same extent such Persons are required to be advanced expenses by, and in accordance with the procedures set forth in, the Company's Organizational Documents and indemnification agreements as in effect on the date of this Agreement and Made Available to Buyer with any directors and officers of the Company.

(b) For a period of six (6) years from and after the Closing, Buyer Parties will cause the Company's Organizational Documents to contain provisions no less favorable with respect to exculpation and indemnification of directors and officers of the Company for periods at or prior to the Closing than are currently set forth in the Company's Organizational Documents.

(c) Seller shall cause the Company to, on or prior to the Closing, purchase a non-cancelable run-off prepaid "tail" insurance policies on terms and conditions providing at least substantially equivalent benefits as the D&O Insurance currently maintained by the Company for the benefit of its directors and officers, which provides such directors and officers with coverage for an aggregate period of six (6) years with respect to claims arising from facts or events that occurred on or before the Closing, including in respect of the transactions

contemplated by this Agreement (the “D&O Insurance”). For a period of six (6) years after the Closing Date, Buyer shall cause the Company to use commercially reasonable efforts to maintain the D&O Insurance in full force and effect and continue to honor the obligations thereunder.

(d) In the event Buyer or the Company (i) consolidates with or merges into any other Person and will not be the continuing or surviving corporation or entity of such consolidation or merger or (ii) transfers all or substantially all of its properties and assets to any Person, then proper provision will be made so that such continuing or surviving corporation or entity or transferee of such assets, as the case may be, will assume the obligations set forth in this Section 4.9.

(e) The obligations under this Section 4.9 will (i) continue, notwithstanding any six (6)-year limitation referred to above, until the final disposition of any action, suit, proceeding or investigation brought or commenced during such six (6)-year period and (ii) not be terminated or modified in such a manner as to adversely affect any indemnitee to whom this Section 4.9 applies without the consent of such affected indemnitee (it being expressly agreed that the indemnitees to whom this Section 4.9 applies will be third-party beneficiaries of this Section 4.9).

4.10 Additional Covenants of Buyer Parties. With respect to the Company’s labor agreements set forth in Section 2.11(b) of the Seller Disclosure Schedule, Buyer Parties shall obtain all consents, provide all notices, complete all information requests required of Buyer Parties, and take all other actions necessary in order to effectuate the transactions contemplated by this Agreement and confirm that such labor agreements remain in full force and effect post-Closing.

#### 4.11 Financing Cooperation .

(a) The Seller shall, and shall cause the Company to, provide and use reasonable best efforts to cause its and the Company’s respective Representatives, including their legal and accounting advisors, to provide, at the sole expense of Parent, all cooperation reasonably requested by Parent in connection with any working capital (or equivalent) debt facilities to be obtained, arranged or committed to on or prior to the Closing Date that is to be made available to the Company from and after the Closing Date, if any (any such debt facility, the “Debt Financing”), including using reasonable best efforts in respect of the following:

(i) executing and delivering as of (but not before) the Closing any pledge and security documents, other definitive financing documents, or other certificates, customary legal opinions from local counsel or documents as may be reasonably requested by Parent (including a certificate of the chief financial officer of the Company with respect to the solvency of the Company on a consolidated basis (without giving effect to the identity of Parent and Buyer)) and otherwise facilitating the pledging of collateral, if any;

(ii) assisting Parent to obtain waivers, consents, estoppels and approvals from other parties to material leases, encumbrances and contracts relating to the Company;

(iii) taking all reasonable actions necessary to (A) permit the Debt Financing sources to evaluate the Company's current assets, cash management and accounting systems, policies and procedures relating thereto for the purposes of establishing collateral arrangements as of the Closing and to assist with other collateral audits and due diligence examinations and (B) establish bank and other accounts and blocked account agreements and lock box arrangements to the extent necessary in connection with the Debt Financing; and

(iv) providing all documentation and other information as is required by applicable "know your customer" and anti-money laundering rules and regulations including the USA PATRIOT Act to the extent reasonably requested by Parent or the Debt Financing sources;

*provided*, that, (i) none of the Seller or Company nor any of their respective Representatives shall be required to (A) pay any commitment or other similar fee or make any other payment in connection with the Debt Financing prior to the Closing that is not simultaneously reimbursed by Parent or (B) take any action that will conflict with or violate the Company's organizational documents, (ii) nothing herein shall require such cooperation to the extent it would, in the good faith determination of the Company, interfere unreasonably with the business or operations of the Company, (iii) the Company shall not be required to commit to take any action in connection with the Debt Financing that is not contingent upon the Closing (including the entry into any agreement) and (iv) neither the Company nor any of its officers, directors or managing members shall be required to take any action or provide any approval in respect of the Debt Financing prior to the Closing (other than those actions contemplated to be taken prior to the Closing pursuant to this [Section 4.11](#)). Nothing contained in this [Section 4.11](#) or otherwise shall require the Company, prior to the Closing, to be an issuer or other obligor with respect to the Debt Financing. Parent shall, promptly upon request by the Company, reimburse the Seller for all reasonable out-of-pocket costs and expenses (including reasonable attorneys' fees) incurred by the Seller or the Company or their respective Representatives in connection with the cooperation contemplated by this [Section 4.11](#) and shall indemnify and hold harmless the Seller and the Company and their respective Representatives from and against any and all losses, liabilities, damages, claims, costs, expenses (including reasonable attorneys' fees), interest, awards, judgments and penalties suffered or incurred by them in connection with the arrangement of the Debt Financing, any action taken by them at the request of Parent pursuant to this [Section 4.11](#) and any information utilized in connection therewith (other than information provided in writing by the Seller or the Company in connection with the Debt Financing), in each case, except to the extent suffered or incurred as a result of the bad faith, gross negligence or willful misconduct by the Seller or Company or their respective Representatives.

(b) The Seller hereby consents to the reasonable use of the Company's logos in connection with the Debt Financing; *provided* that such logos are used solely in a manner that does not violate any contractual obligation of the Company and is not intended or reasonably likely to harm, disparage or otherwise adversely affect the Company.

(c) Parent may reasonably request the cooperation of the Seller and the Company under this [Section 4.11](#) at any time, and from time to time and on multiple occasions, between the date hereof and the Closing to effect the Debt Financing.

(d) Parent acknowledges and agrees that the obtaining of any Debt Financing is not a condition to Closing and reaffirms its obligation to consummate the transactions contemplated by this Agreement irrespective and independently of the availability of any Debt Financing, subject to the satisfaction or waiver of the conditions set forth in Article V.

(e) All non-public or otherwise confidential information regarding the Company obtained by Parent or its Representatives pursuant to this Section 4.11 shall be kept confidential in accordance with the Confidentiality Agreement.

4.12 Payoff Letters. At least five (5) Business Days prior to the anticipated Closing Date, Seller shall deliver, or cause to be delivered, to Buyer forms of payoff letters (the "Payoff Letters"), in form and substance reasonably satisfactory to Buyer, providing for the satisfaction and discharge of all amounts due under (including principal of, interest on, premium, if any, and any expenses, break fees or other amounts owing in respect of), and the termination of all obligations (including the release of all Liens and termination of all applicable loan documents) with respect to (i) all Indebtedness for borrowed money of the Company (which, for the avoidance of doubt, shall not include any Permitted Company Debt) (the "Funded Debt"), and (ii) the Purchased Aircraft Letters of Credit, to the holders of the Funded Debt. Seller, the Company and Buyer shall cooperate in arranging for the repayment by the Company of the Funded Debt and the termination of the commitments of the Payoff Lenders at the Closing. The Company shall facilitate such repayment and the release, in connection with such repayment, of any Liens securing the Funded Debt.

#### 4.13 Termination of Affiliate Agreements.

(a) Except as set forth on Section 4.13 of the Seller Disclosure Schedule, on or before the Closing Date, all Liabilities between the Company, on the one hand, and one or more of its Affiliates (including Affiliates of Seller or its members), on the other hand, including any and all Contracts between the Company, on the one hand, and one or more of its Affiliates (including Affiliates of Seller or its members), on the other hand, shall be terminated in full, without any Liability to Buyer, the Company or any of their respective Affiliates following the Closing.

(b) As promptly as practicable after the date of this Agreement, Seller and Buyer shall cooperate and assist each other in identifying any services that Seller or one of its Affiliates may need to continue to provide to the Company immediately following the Closing for a limited time period and, if necessary, negotiate in good faith the terms of a transition services agreement between Seller and such Affiliates and the Company (the "Transition Services Agreement") which shall set forth the terms, conditions and fees with respect to the provision of such services. The parties hereto shall work in good faith to prepare, as soon as reasonably practicable after the date of this Agreement (and in all events by the fifth (5<sup>th</sup>) day prior to the Closing Date), a final Transition Services Agreement, including descriptions of the transitional services and the terms and service fees corresponding thereto.

4.14 Resignations. Seller shall cause the Company to deliver to Buyer on the Closing Date such resignations of members of the board of directors or governors of the Company and of officers of the Company which have been requested in writing by Buyer at least five (5) Business Days prior to the Closing, such resignations to be effective concurrently with the Closing.

4.15 Books and Records. On the Closing Date or promptly thereafter, Seller will deliver or make available to Buyer at the offices of the Company all of the books and records of the Company to the extent such books and records are not located at the offices of the Company prior to the Closing, and if after the Closing Seller discovers in its or its Affiliates' possession or if any, under its or its Affiliates' control any other such books and records, it will promptly deliver such books and records to Buyer (which, for the avoidance of doubt, shall include delivery to the offices of the Company).

4.16 Preparation of Closing Deliverables. As promptly as practicable after the date of this Agreement, the parties hereto shall, and Seller shall cause the Company to, cooperate and negotiate in good faith to prepare and finalize each of the Transaction Documents that will be entered into at the Closing and the Mutual Releases, including all schedules, exhibits and appendices thereto, at least five (5) prior to the Closing Date.

4.17 Name Change. Within 30 days following the Closing Date, Seller shall cause the filing of Articles of Amendment with the Minnesota Secretary of State to change the name of Sun Country Real Estate Holdings, LLC and shall take all other action necessary to change Seller's legal, registered, assumed, trade and "doing business as" name, as applicable, to a name that does not include the words "Sun Country" or any name confusingly similar to the foregoing and will cause to be filed as soon as practicable after the Closing, in all jurisdictions in which Seller is qualified to do business, any documents necessary to reflect such change in its legal, registered, assumed, trade and "doing business as" name, as applicable, or to terminate its qualification therein.

4.18 Post-Closing Available Funds of Seller. From the Closing Date until the date on which the Adjustment Escrow Fund is released in accordance with Section 1.4(c), the Seller shall retain and be capitalized with a minimum of \$5,000,000 in unrestricted cash, all of which shall be available to pay any shortfall amount owing and payable to Buyer in accordance with Section 1.4(c) (if at all).

## ARTICLE V

### CONDITIONS TO PURCHASE

5.1 Conditions to Each Party's Obligation to Effect the Transaction. The respective obligations of the parties to effect the transactions contemplated hereby shall be subject to the satisfaction, or waiver by each of the parties, at or prior to the Closing of the following conditions:

(a) Approvals or authorizations required to be obtained from the FAA, DOT, and such other Governmental Entity as set forth and specifically described on Section 5.1(a) of the Seller Disclosure Schedule to this Agreement shall have been obtained.

(b) The waiting period under the HSR Act shall have expired or been earlier terminated.



(c) No Governmental Entity of competent jurisdiction shall have enacted, issued, promulgated, enforced or entered any order, executive order, stay, decree, judgment or injunction (preliminary or permanent) or statute, rule or regulation which is in effect and which has the effect of making the purchase of the Units illegal or otherwise prohibiting consummation of the purchase of the Units or the other transactions contemplated by this Agreement and there shall be no Proceeding pending by or before any Governmental Entity of competent jurisdiction seeking the foregoing.

5.2 Conditions to the Obligations of Buyer. The obligations of Buyer to effect the purchase of the Units shall also be subject to the satisfaction on or prior to the Closing Date of the following conditions, any of which may be waived, in writing, exclusively by Buyer:

(a) (i) The representations and warranties of Seller set forth in this Agreement (other than as set forth in Sections 2.1, 2.2, 2.3, 2.4, 2.9(c) and 2.21) shall be true and correct in all respects (without giving effect to any materiality or Material Adverse Effect qualifiers set forth therein) on and as of the Closing Date as if made on and as of such date (except for those representations and warranties that relate to a particular date, which representations and warranties shall be true and correct in all respects as of such date) except, in either case, where the failure of such representations to be so true and correct has not had and would not reasonably be expected to have a Material Adverse Effect and (ii) each of the representations and warranties of Seller set forth in Sections 2.1, 2.2, 2.3, 2.4, 2.9(c) and 2.21 of this Agreement shall be true and correct in all respects on and as of the Closing Date as if made on and as of such time (except for those representations and warranties that relate to a particular date, which representations and warranties shall be true and correct in all respects as of such date).

(b) Seller shall have performed and complied in all material respects the agreements, covenants and obligations required to be performed by it under this Agreement on or prior to the Closing Date.

(c) No Material Adverse Effect has occurred or is continuing.

(d) Seller shall have paid, or caused the payment of, all Related Party Loan Receivables and all Related Party Loan Payables and each of the Company's and Seller's Chief Financial Officer or equivalent officer shall have delivered an affidavit confirming the payoff and/or cancellation of such obligations as of the Closing.

(e) Seller shall have signed and delivered, and caused the Company to sign and deliver, to Buyer a mutual release agreement, in a form reasonably acceptable to Buyer and Seller (the "Mutual Release"), whereby Seller releases claims against the Company and the Buyer Parties and their Affiliates, that arise from or relate to obligations, liabilities or causes of action that first arose prior to the Closing, and the Company and Buyer Parties release claims against Seller and its Affiliates, including Cambria Company, LLC, that arise from or relate to obligations, liabilities or causes of action that first arose prior to the Closing, in each case, except for such obligations arising from or relating to the Transaction Documents.

(f) The Company shall have obtained each third party consent and/or approval set forth on Section 5.2(f) of the Seller Disclosure Schedule.

(g) Seller shall have delivered to Buyer all of Seller deliveries required pursuant to Section 1.5 hereof.

5.3 Conditions to the Obligations of Seller. The obligations of Seller to effect this Agreement shall also be subject to the satisfaction on or prior to the Closing Date of the following conditions, either of which may be waived, in writing, exclusively by Seller:

(a) The representations and warranties of Buyer set forth in this Agreement shall be true and correct in all respects on and as of the Closing Date except, in each case, where the failure of such representations to be so true and correct, considered as a whole, has not had and would not result in a Buyer Material Adverse Effect.

(b) Buyer shall have performed in all material respects the agreements, covenants and obligations required to be performed by it under this Agreement on or prior to the Closing Date.

(c) Buyer Parties shall have signed and delivered to Seller the Mutual Release.

(d) Buyer shall have delivered to Seller all of Buyer deliveries required pursuant to Section 1.6 hereof.

## ARTICLE VI

### TERMINATION AND AMENDMENT

6.1 Termination. This Agreement may be terminated at any time prior to the Closing Date:

(a) By mutual written consent of Buyer and Seller; or

(b) By either Buyer or Seller if (i) a Governmental Entity of competent jurisdiction shall have issued a non-appealable final order, decree or ruling or taken any other non-appealable final action, in each case having the effect of permanently restraining, enjoining or otherwise prohibiting the purchase of the Units, (ii) the transactions contemplated hereby shall not have been consummated on or before April 1, 2018, subject to extension (x) upon notice in writing by either party to the other party, for up to a maximum of an additional thirty (30) calendar days if the failure to consummate the transactions contemplated hereby was due to the actions or inactions of a third party (the "End Date") or (y) by mutual agreement of Seller and Buyer; *provided, however*, the right to terminate this Agreement under this Section 6.1(b) shall not be available to any party whose breach of any representation or warranty or failure to fulfill any covenant or agreement hereunder has been the cause of the failure of the transactions to occur on or before the End Date;

(c) By Buyer, if (i) there has been a breach of or failure in any material respect of any representation or warranty on the part of Seller as set forth in this Agreement, or (ii) there has been a breach of or failure in any material respect in the performance of any of the covenants set forth in this Agreement and such breach or nonperformance is not cured (x) after notice and reasonable opportunity to do so (but in no event more than ten (10) Business Days) or (y) by the End Date.

(d) By Seller, if (i) there has been a breach of or failure in any material respect of any representation or warranty on the part of Buyer as set forth in this Agreement, or (ii) there has been a breach of or failure in any material respect in the performance of any of the covenants set forth in this Agreement and such breach or nonperformance is not cured (x) after notice and reasonable opportunity to do so (but in no event more than ten (10) Business Days) or (y) by the End Date.

6.2 Notice of Termination. The party desiring to terminate this Agreement pursuant to Section 6.1 shall give written notice of such termination to the other party to this Agreement in accordance with Section 7.2, specifying the provision(s) pursuant to which such termination is effective.

6.3 Effect of Termination. In the event of termination of this Agreement as provided in Section 6.1, this Agreement shall immediately become void and there shall be no liability or obligation on the part of Buyer or Seller; *provided, however*, that (a) the provisions of the Confidentiality Agreement, Section 4.6 (Confidential Information), Section 4.8 (Public Disclosure), this Section 6.3 (Effect of Termination), and Article VII (Miscellaneous Provisions), and the rights and obligations of the parties thereunder, shall survive any such termination and remain in full force and effect; and (b) nothing herein shall relieve any party from liability for any fraud or intentional misrepresentation under, or any knowing and intentional breach of, this Agreement prior to the date of termination.

## ARTICLE VII

### MISCELLANEOUS PROVISIONS

7.1 Non-Survival of Representations and Warranties. None of the representations, warranties and covenants (to the extent such covenants relate to the performance of obligations prior to the Closing) contained in this Agreement or in any instrument delivered under this Agreement shall survive the Closing Date. This Section 7.1 does not limit any covenant of the parties to this Agreement which, by its terms, contemplates performance after the Closing Date. For the avoidance of doubt, the covenants of the parties to this Agreement pursuant to Sections 4.6 and 4.7 shall survive the Closing Date and shall require performance after the Closing Date in accordance with their terms.

7.2 Notices. All notices and other communications hereunder shall be in writing and shall be deemed duly delivered on the earliest to occur of: (i) four (4) Business Days after being sent by registered or certified mail, return receipt requested, postage prepaid, (ii) one (1) Business Day after being sent for next Business Day delivery, fees prepaid, via a reputable nationwide overnight courier service, or (iii) on the Business Day the email or facsimile is sent,

if such email or facsimile is sent is sent between 9:00 a.m. and 5:00 p.m. in the time zone of the recipient of the email or facsimile, and if such email or facsimile is sent after 5:00 p.m. in the time zone of the recipient of the email or facsimile on the next Business Day, in each case to the intended recipient as set forth below:

(a) IF TO BUYER OR PARENT, TO:

c/o Apollo Management VIII, L.P.  
2000 Avenue of the Stars, Suite 510 N  
Los Angeles, CA 90067  
Attention: Antoine G. Munfakh  
[amunfakh@apollolp.com](mailto:amunfakh@apollolp.com)

with a copy to:

Paul, Weiss, Rifkind, Wharton & Garrison LLP  
1285 Avenue of the Americas  
New York, NY 10019  
Attention: Brian P. Finnegan  
[bfinnegan@paulweiss.com](mailto:bfinnegan@paulweiss.com)

(b) IF TO SELLER, TO:

Minnesota Aviation, LLC  
c/o Cambria USA  
805 Enterprise Drive East  
Suite H  
Belle Plaine, MN 56011  
Attention: Jim Ward, Chief Financial Officer  
[Jim.Ward@cambriaUSA.com](mailto:Jim.Ward@cambriaUSA.com)

with a copy to:

Briggs and Morgan, P.A.  
2200 IDS Center  
80 South 8th Street Attention: Charles W. Johnson  
[cjohnson@briggs.com](mailto:cjohnson@briggs.com)

Any party to this Agreement may give any notice or other communication hereunder using any other means (including personal delivery, messenger service, telex, ordinary mail or electronic mail), but no such notice or other communication shall be deemed to have been duly given unless and until it actually is received by the party for whom it is intended. Any party to this Agreement may change the address to which notices and other communications hereunder are to be delivered by giving the other parties to this Agreement notice in the manner herein set forth.

7.3 Entire Agreement. This Agreement (including the Schedules and Exhibits hereto and the documents and instruments referred to herein that are to be delivered at the Closing) constitutes the entire agreement among the parties to this Agreement and supersedes any prior understandings, agreements or representations by or among the parties hereto, or any of them, written or oral, with respect to the subject matter hereof.

7.4 No Third Party Beneficiaries. This Agreement is not intended, and shall not be deemed, to confer any rights or remedies upon any Person other than the parties hereto and their respective successors and permitted assigns, to create any agreement of employment with any Person or to otherwise create any third-party beneficiary hereto.

7.5 Assignment. Neither this Agreement nor any of the rights, interests or obligations under this Agreement may be assigned or delegated, in whole or in part, by operation of Law or otherwise by any party without the prior written consent of the other parties, and any such assignment without such prior written consent shall be null and void; *provided, however*, that each of Buyer Parties may assign its rights under this Agreement to one or more Affiliates of Apollo Management VIII, L.P. (*provided, however*, that such assignment shall not relieve Buyer or Parent, as applicable, of any liability or obligation in connection with this Agreement, and *provided, further* that any such assignment shall not materially impede or delay the consummation of the Contemplated Transactions). Subject to the first sentence of this Section 7.5, this Agreement shall be binding upon, inure to the benefit of and be enforceable by, the parties hereto and their respective successors and permitted assigns.

7.6 Severability. Any term or provision of this Agreement that is invalid or unenforceable in any situation in any jurisdiction shall not affect the validity or enforceability of the remaining terms and provisions hereof or the validity or enforceability of the offending term or provision in any other situation or in any other jurisdiction. If the final judgment of a court of competent jurisdiction declares that any term or provision hereof is invalid or unenforceable, the parties hereto agree that the court making such determination shall have the power to limit the term or provision, to delete specific words or phrases, or to replace any invalid or unenforceable term or provision with a term or provision that is valid and enforceable and that comes closest to expressing the intention of the invalid or unenforceable term or provision; and this Agreement shall be enforceable as so modified. In the event such court does not exercise the power granted to it in the prior sentence, the parties hereto agree to replace such invalid or unenforceable term or provision with a valid and enforceable term or provision that will achieve, to the extent possible, the economic, business and other purposes of such invalid or unenforceable term.

7.7 Counterparts and Signature. This Agreement may be executed in two or more counterparts, each of which shall be deemed an original but all of which together shall be considered one and the same agreement and shall become effective when counterparts have been signed by each of the parties hereto and delivered to the other parties, it being understood that all parties need not sign the same counterpart. This Agreement may be executed and delivered by PDF or other facsimile transmission.

7.8 Interpretation. Appendices, Exhibits and Schedules to this Agreement are attached hereto and by this reference incorporated herein for all purposes. When reference is made in this Agreement to an Article, an Appendix, an Exhibit, a Schedule or a Section, such

reference shall be to an Article, Appendix, Exhibit, Schedule or Section of this Agreement unless otherwise indicated. The table of contents and headings contained in this Agreement are for convenience of reference only and shall not affect in any way the meaning or interpretation of this Agreement. The language used in this Agreement shall be deemed to be the language chosen by the parties hereto to express their mutual intent, and no rule of strict construction shall be applied against any party. Whenever the context may require, any pronouns used in this Agreement shall include the corresponding masculine, feminine or neuter forms, and the singular form of nouns and pronouns shall include the plural, and vice versa. Any reference to any federal, state, local or foreign statute or Law shall be deemed also to refer to all rules and regulations promulgated thereunder, unless the context requires otherwise. The word "or" shall be disjunctive but not exclusive. The words "this Agreement," "herein," "hereby," "hereunder" and "hereof," and words of similar import, refer to this Agreement as a whole and not to any particular subdivision unless expressly so limited. Where this Agreement states that a Party "shall," "will" or "must" perform in some manner or otherwise act or omit to act, it means the Party is legally obligated to do so in accordance with this Agreement. Whenever the words "include," "includes" or "including" are used in this Agreement, they shall be deemed to be followed by the words "without limitation." All references to "dollar" or "dollars" (\$) in this Agreement shall mean United States dollars. Whenever this Agreement refers to a number of days, such number shall refer to calendar days unless Business Days are specified. No summary of this Agreement prepared by any party shall affect the meaning or interpretation of this Agreement.

7.9 Governing Law. This Agreement shall be governed by and construed in accordance with the internal Laws of the State of Delaware without giving effect to any choice or conflict of law provision or rule (whether of the State of Delaware or any other jurisdiction) that would cause the application of Laws of any jurisdictions other than those of the State of Delaware.

7.10 Submission to Jurisdiction; Waiver of Jury Trial.

(a) Each of the parties to this Agreement (a) consents to submit itself to the exclusive personal jurisdiction and venue of the state and federal courts sitting in St. Paul, Minnesota in any action or proceeding arising out of or relating to this Agreement or any of the transactions contemplated by this Agreement, (b) agrees that all claims in respect of such action or proceeding may be heard and determined in any such court, (c) agrees that it shall not attempt to deny or defeat such personal jurisdiction by motion or other request for leave from any such court, and (d) agrees not to bring any action or proceeding arising out of or relating to this Agreement or any of the transactions contemplated by this Agreement in any other court. Each of the parties hereto waives any defense of inconvenient forum to the maintenance of any action or proceeding so brought and waives any bond, surety or other security that might be required of any other party with respect thereto. Any party hereto may make service on another party by sending or delivering a copy of the process to the party to be served, at the address and in the manner provided for the giving of notices in Section 7.2. Nothing in this Section 7.10, however, shall affect the right of any party to serve legal process in any other manner permitted by Law.

(b) EACH PARTY ACKNOWLEDGES AND AGREES THAT ANY CONTROVERSY WHICH MAY ARISE UNDER THIS AGREEMENT IS LIKELY TO

INVOLVE COMPLICATED AND DIFFICULT ISSUES, AND THEREFORE EACH SUCH PARTY HEREBY IRREVOCABLY AND UNCONDITIONALLY WAIVES ANY RIGHT SUCH PARTY MAY HAVE TO A TRIAL BY JURY IN RESPECT OF ANY LEGAL ACTION DIRECTLY OR INDIRECTLY ARISING OUT OF OR RELATING TO THIS AGREEMENT OR THE TRANSACTIONS CONTEMPLATED HEREBY. EACH PARTY CERTIFIES AND ACKNOWLEDGES THAT (i) NO REPRESENTATIVE, AGENT OR ATTORNEY OF ANY OTHER PARTY HAS REPRESENTED, EXPRESSLY OR OTHERWISE, THAT SUCH OTHER PARTY WOULD NOT, IN THE EVENT OF LITIGATION, SEEK TO ENFORCE THE FOREGOING WAIVER, (ii) EACH PARTY UNDERSTANDS AND HAS CONSIDERED THE IMPLICATIONS OF THIS WAIVER, (iii) EACH PARTY MAKES THIS WAIVER VOLUNTARILY, AND (iv) EACH PARTY HAS BEEN INDUCED TO ENTER INTO THIS AGREEMENT BY, AMONG OTHER THINGS, THE MUTUAL WAIVERS AND CERTIFICATIONS IN THIS SECTION 7.10.

7.11 Further Assurances. Each party agrees to cooperate reasonably and in good faith with the other parties and to execute such further instruments, documents and agreements and to give such further written assurances as may be reasonably requested by any other party to evidence and reflect the transactions described herein and contemplated hereby and to carry into effect the intent and purpose of this Agreement. Seller agrees to cause the Company to cooperate reasonably and in good faith with the other parties and to execute such further instruments, documents and agreements and to give such further written assurances as may be reasonably requested by any other party to evidence and reflect the transactions described herein and contemplated hereby and to carry into effect the intent and purpose of this Agreement.

7.12 Disclosure Schedule. Seller Disclosure Schedule shall be arranged in Sections corresponding to the numbered Sections contained in Article II and the other Articles of this Agreement.

7.13 Expenses. Each party to this Agreement shall be responsible for all such party's legal or other expenses in connection with this Agreement; provided that Seller shall bear all Unpaid Transaction Expenses as provided for herein.

7.14 Specific Performance. The parties agree that irreparable damage would occur in the event that any of the provisions of this Agreement were not performed in accordance with their specific terms or were otherwise breached. It is accordingly agreed that the parties hereto will be entitled to seek an injunction or injunctions to prevent breaches of this Agreement and to enforce specifically the terms and provisions hereof in any court referred to in Section 7.10, this being in addition to any other remedy to which the parties are entitled at Law or in equity.

## ARTICLE VIII

### DEFINITIONS

For purposes of this Agreement, the following terms have the meanings specified or referred to in this Article VIII:

“Accounting Principles” means GAAP, and to the extent consistent with GAAP, the accounting principles, policies, practices, procedures and methods, with consistent classification, judgments and estimation methodology that were used in preparation of the Company Audited Financial Statements as of December 31, 2016, and the specific policies and rules set forth on Appendix A; *provided* that in the event of any conflict between the such accounting principles, methods and practices and the rules set forth on Appendix A, the rules set forth on Appendix A shall govern.

“Adjustment Escrow Amount” means \$1,000,000.

“Adjustment Escrow Fund” has the meaning set forth in Section 1.3(b)(iii).

“Adjustment Time” means 11:59 pm (Central time) on the day immediately prior to the Closing.

“Affiliate” or “affiliate” means a Person that directly or indirectly, through one or more intermediaries, controls, is controlled by, or is under common control with, the first-mentioned Person; *provided* that in no event shall Parent, Buyer or any of their respective subsidiaries be considered an Affiliate of any portfolio company or investment fund (excluding investment funds focused on private equity) affiliated with Apollo Global Management, LLC, nor shall any portfolio company or investment fund (excluding investment funds focused on private equity) affiliated with Apollo Global Management, LLC, be considered to be an Affiliate of Parent, Buyer or any of their respective subsidiaries.

“Affiliate Lease Amendments” means amendments to (a) that certain Lease Agreement, dated April 30, 2015, by and between Davis Family Minnesota, LLC, as landlord, and the Company, as tenant and (b) that certain Lease Agreement, dated December 4, 2013, by and between Sun Country Real Estate Holdings, LLC, as landlord, and the Company, as tenant, in each case reflecting the terms set forth on Appendix D.

“Agreement” has the meaning set forth in the opening paragraph of this Agreement.

“Aircraft” has the meaning set forth in Section 2.22(a).

“Airport” has the meaning set forth in Section 2.24.

“Allocation Schedule” has the meaning set forth in Section 1.9.

“Anticorruption Laws” means the US Foreign Corrupt Practices Act of 1977, as amended, and any other anticorruption or anti-bribery Law applicable to the Company.

“Aviation Regulations” has the meaning set forth in Section 2.5(b).

“Blue Sky Laws” means any state securities, “blue sky” or takeover law.

“Business” means the business conducted by the Company.



“Business Day” means any day (other than Saturday or Sunday) on which commercial banks banking in the County of New York, New York are not required or permitted by Law to close.

“Buyer” has the meaning set forth in the opening paragraph of this Agreement.

“Buyer Disclosure Schedule” has the meaning set forth in the introductory paragraph to Article III.

“Buyer Material Adverse Effect” means any change, event, development, condition, occurrence or effect that prevents or materially delays, or would prevent or delay beyond the End Date, consummation of the transactions contemplated by this Agreement by Buyer.

“Buyer Parties” has the meaning set forth in the opening paragraph of this Agreement.

“Closing” has the meaning set forth in Section 1.7.

“Closing Cash” means all cash and cash equivalents of the Company as of the Adjustment Time, calculated in accordance with the Accounting Principles, plus an amount equal to inbound wires in transit and checks presented by the Company for deposit but not yet credited to deposit accounts and customer deposits and minus an amount equal to outbound wires in transit and checks written by the Company that have not yet been presented for deposit; *provided*, that Closing Cash shall exclude (i) any cash or cash equivalents not freely usable because such amounts are subject to restrictions, limitations or taxes on use or distribution by Law, Contract or otherwise, including escrowed cash, restrictions on dividends and repatriations or any other form of restriction and (ii) any amounts collateralizing outstanding letters of credit.

“Closing Date” has the meaning set forth in Section 1.7.

“Closing Statement” has the meaning set forth in Section 1.4(d)(i).

“Code” has the meaning set forth in Section 1.9.

“Company” has the meaning set forth in the Recitals.

“Company Affiliated Person” means: (i) any director, governor, manager or officer of the Company; (ii) Seller or any parent entity that directly or indirectly controls Seller; (iii) any equity holder of Seller that is an individual and any director, manager or officer of Seller; (iv) any spouse, child, parent or other immediate relative of any of the individuals referenced in the foregoing clauses; or (v) any Affiliate of any of the individuals referenced in the foregoing clauses.

“Company Audited Financial Statements” has the meaning set forth in Section 2.7(a).

“Company Benefit Plans” means, other than Foreign Benefit Plans, all “employee benefit plans” as defined in Section 3(3) of ERISA and all bonus, stock option, stock purchase, stock appreciation rights, restricted stock, stock-based or other equity-based, incentive, profit-sharing, deferred compensation, vacation, insurance, medical, welfare, fringe, retirement, retiree medical or life insurance, death benefit, supplemental retirement, severance, termination or change in control, Code Section 125 “cafeteria” or “flexible” benefit, employee loan, relocation or other benefit plans, programs or arrangements, and all employment, consulting, termination, severance, retention or other contracts or agreements, whether or not in writing and whether or not funded, to which Seller is a party, with respect to which Seller has or may have any obligation, or which are maintained, contributed to or sponsored by Seller for the benefit of any current or former employee, officer, director or consultant of Seller.

“Company Debt” means the aggregate amount of Indebtedness of the Company as of the Adjustment Time, calculated in accordance with the Accounting Principles, and for the avoidance of doubt, without giving effect to the transactions contemplated by this Agreement or any purchase accounting arising from the consummation of the transactions contemplated by this Agreement. Company Debt specifically does not include (i) any Indebtedness of Seller unless such Indebtedness is secured by the assets of the Company or the Company is made a guarantor or obligor thereunder, (ii) any Indebtedness incurred by Buyer and its Affiliates (and subsequently assumed by the Company or any Company Subsidiary) on the Closing Date, (iii) any amounts included as Unpaid Transaction Expenses, (iv) obligations with respect to the Purchased Aircraft including the Purchased Aircraft Letters of Credit, and (v) any obligations arising prior to the Closing with respect to the Company’s pursuit of the actions described in the Company Growth Plan (provided that the Company complies with the notice process described in the Company Growth Plan); and specifically includes any Related Party Loan Payables unpaid as of the Adjustment Time.

“Company Financial Statements” has the meaning set forth in Section 2.7(a).

“Company Growth Plan” means the actions described in Appendix B hereto.

“Company Interim Financial Statements” has the meaning set forth in Section 2.7(a).

“Company Slots” has the meaning set forth in Section 2.23.

“Confidential Information” has the meaning set forth in Section 4.5(b).

“Confidentiality Agreement” has the meaning set forth in Section 4.5(b).

“Contemplated Transactions” means the transactions contemplated by the Transaction Documents.

“Contracts” means any legally binding contract, agreement, indenture, note, bond, license, lease, sublease, instrument, obligation, understanding, undertaking, permit, concession, franchise or any other legally binding commitment, plan or arrangement, whether oral or written, including all amendments thereto.

“D&O Insurance” has the meaning set forth in Section 4.9(c).

“DHS” has the meaning set forth in Section 2.5(b).

“DOT” has the meaning set forth in Section 2.5(b).

“End Date” has the meaning set forth in Section 6.1(b).

“Environmental Laws” means any and all international, federal, state, local or foreign Laws, statutes, ordinances, regulations, treaties, policies, guidance, rules, judgments, orders, writs, court decisions or rule of common law, stipulations, injunctions, consent decrees, permits, restrictions and licenses, which (a) regulate or relate to the protection or clean-up of the environment; the use, treatment, storage, transportation, handling, disposal or Release of Hazardous Substances, the preservation or protection of waterways, groundwater, drinking water, air, wildlife, plants or other natural resources, or the health and safety of Persons or property, including protection of the health and safety of employees; or (b) impose liability or responsibility with respect to any of the foregoing. For clarity, “Environmental Laws” includes the Airport Noise and Capacity Act of 1990 (49 U.S.C. § 47521 et seq.), the Clean Air Act (42 U.S.C. § 7401 et seq.), the Resource Conservation and Recovery Act (42 U.S.C. § 6901 et seq.), the Clean Water Act (33 U.S.C. § 1251 et seq.), the Safe Drinking Water Act (42 U.S.C. § 300f et seq.), the Comprehensive Environmental Response, Compensation and Liability Act, Superfund Amendments and Reauthorization Act (42 U.S.C. § 9601 et seq.), the Federal Insecticide, Fungicide, and Rodenticide Act (7 U.S.C. § 136 et seq.), the Toxic Substances Control Act (15 U.S.C. § 2601 et seq.) the Hazardous Materials Transportation Act (49 U.S.C. § 5101 et seq.), the Emergency Planning & Community Right-to-Know Act (42 U.S.C. § 11001 et seq.), the Federal Food, Drug and Cosmetic Act (21 U.S.C. § 301 et seq.) and the Oil Pollution Control Act (33 U.S.C. § 2701 et seq.) and any foreign, state or local counterparts.

“Environmental Permits” means any permit, approval, identification number, license and other authorization required under any applicable Environmental Law.

“Equity Interest” means any share, capital stock, voting securities, partnership, membership, ownership or similar interest in any Person, and any option, warrant, right or security (including debt securities) convertible, exchangeable or exercisable thereto or therefor.

“ERISA” means the Employee Retirement Income Security Act of 1974.

“ERISA Affiliate” of any entity means any other entity which, together with such entity, would be treated as a single employer under Section 414 of the Code.

“Escrow Agent” has the meaning set forth in Section 1.3(b)(iii).

“Escrow Agreement” means an agreement on customary terms with respect to the Adjustment Escrow Fund by and between the Escrow Agent, Buyer and Seller, reasonably acceptable to Buyer and Seller in form and substance.

“Estimated Closing Cash” has the meaning set forth in Section 1.4(a).

“Estimated Closing Statement” has the meaning set forth in Section 1.4(a).

“Estimated Company Debt” has the meaning set forth in Section 1.4(a).

“Estimated Net Working Capital Amount” has the meaning set forth in Section 1.4(a).

“Estimated Purchase Price” has the meaning set forth in Section 1.4(a).

“Estimated Unpaid Transaction Expenses” has the meaning set forth in Section 1.4(a).

“Exchange Act” means the Securities Exchange Act of 1934, as amended.

“Export Control Laws” means all export control and import laws and regulations, including applicable to the Company and its operations, including without limitation the United States Export Administration Act and implementing Export Administration Regulations, the Arms Export Control Act and implementing International Traffic in Arms Regulations, and the regulations of the U.S. Customs and Border Protection.

“FAA” has the meaning set forth in Section 2.5(b).

“FCC” has the meaning set forth in Section 2.5(b).

“Filing” has the meaning set forth in Section 4.4(c).

“Final Closing Cash” has the meaning set forth in Section 1.4(b).

“Final Company Debt” has the meaning set forth in Section 1.4(b).

“Final Net Working Capital Amount” has the meaning set forth in Section 1.4(b).

“Final Unpaid Transaction Expenses” has the meaning set forth in Section 1.4(b).

“Foreign Benefit Plans” means benefit plans that are comparable to Company Benefit Plans that are maintained for the benefit of any current or former employee, officer or director of Seller who is located primarily in a country other than the United States and/or their dependents or that are subject to the laws of any jurisdictions other than the United States, excluding any benefit plan mandated or pursuant to which Seller is required to contribute, in either case, under applicable Law.

“Funded Debt” has the meaning set forth in Section 4.12.

“GAAP” means the Generally Accepted Accounting Principles in the United States.

“Government Official” means any director, officer, or employee of a Governmental Entity or any commercial enterprise controlled by a Governmental Entity, or of a public international organization, or any political party official or candidate for political office.

“Governmental Entity” means any nation, federal, state, county municipal, local or foreign government, or other political subdivision thereof or any other governmental, administrative, judicial, arbitral, legislative, executive, regulatory or self-regulatory authority, instrumentality, agency, commission or body and any entity exercising executive, legislative, judicial, regulatory, taxing or administrative functions of or pertaining to government.

“Hazardous Substances” means any pollutant, chemical, substance, and any toxic, infectious, carcinogenic, reactive, corrosive, ignitable or flammable chemical, or chemical compound, or hazardous substance, material or waste, or any infectious agent or biological material, whether solid, liquid or gas, that is subject to regulation, control or remediation under any Environmental Laws, including without limitation, any quantity of asbestos in any form, urea formaldehyde, PCBs, radon gas, mold, crude oil or any fraction thereof, all forms of natural gas, petroleum products or by-products or derivatives.

“HSR Act” means the Hart-Scott-Rodino Antitrust Improvements Act of 1976.

“Indebtedness” means, of any Person, without duplication, (i) indebtedness for borrowed money or indebtedness issued or incurred in substitution or exchange for indebtedness for borrowed money, (ii) amounts owing as deferred purchase price for property, assets, businesses, securities or services, including all seller notes and “earn-out” payments, but excluding obligations relating to the Purchased Aircraft (including the Purchased Aircraft Letters of Credit), (iii) indebtedness evidenced by any note, bond, debenture, mortgage or other debt instrument or debt security, (iv) obligations under any performance bond or letter of credit, but only to the extent drawn, called or secured by Seller or Company loan facilities prior to the Closing, (v) all capitalized lease obligations, (vi) all obligations payable upon settlement or termination on the Closing Date of any obligations of the Company under interest rate swap, currency swap, forward currency, derivative or interest rate contracts or other interest rate, currency or hedging arrangements, (vii) guarantees with respect to any indebtedness of any other Person of a type described in clauses (i) through (vi) above and (viii) for clauses (i) through (vii) above, all accrued interest thereon, if any, and any termination fees, prepayment penalties, “breakage” cost or similar payments associated with the repayments of such Indebtedness on the Closing Date to the extent paid on the Closing Date. For the avoidance of doubt, Indebtedness shall not include (A) any obligations under any performance bond or letter of credit to the extent not drawn, called or secured by Seller or Company loan facilities or (B) any endorsement of negotiable instruments for collection in the ordinary course of business.

“Independent Accounting Firm” means Ernst & Young LLP, or if Ernst & Young LLP is not available for such assignment, another nationally recognized accounting firm reasonably agreed upon by the parties and who is not the CPA firm that audits or otherwise provides frequent services to any of the parties or that has audited or provided frequent services to a party during the preceding five (5) years.

“Insurance Policies” has the meaning set forth in Section 2.17.

“Intellectual Property Rights” means all (a) U.S. and foreign patents and patent applications and disclosures relating thereto (and any patents that issue as a result of those patent applications), and any renewals, reissues, reexaminations, extensions, continuations,

continuations-in-part, divisions and substitutions relating to any of the patents and patent applications, as well as all related foreign patent and patent applications that are counterparts to such patents and patent applications, and any patentable inventions, (b) U.S. and foreign trademarks, service marks, trade dress, logos, trade names, corporate names, social media identifiers and related accounts, brand names and logos, whether registered or unregistered, and the goodwill associated therewith, together with any registrations and applications for registration thereof, (c) U.S. and foreign copyrights, designs and rights under copyrights, whether registered or unregistered, including moral rights, and any registrations and applications for registration thereof, (d) rights in databases and data collections (including knowledge databases, customer lists and customer databases) under the laws of the United States or any other jurisdiction, whether registered or unregistered, and any applications for registration therefor, (e) Trade Secrets, (f) Software and (g) URL and Internet domain name registrations.

“IP License Side Letter” means the letter agreement between Cambria Company LLC and the Company, in the form attached hereto as Appendix C.

“IRS” means the United States Internal Revenue Service.

“Knowledge” means (a) when used in reference to the Company, the knowledge of the Chief Executive Officer, the Executive Vice President of Finance, the Chief Operating Officer and the General Counsel of the Company, in each case based on the knowledge that a reasonable officer holding such position would have, (b) when used in reference to Seller, the knowledge of the directors and executive officers of Seller, in each case based on the knowledge that a reasonable officer holding such position would have and through the Closing Date, and (c) when used in reference to Buyer, the knowledge of the directors and officers of Buyer or Parent, in each case based on the knowledge that a reasonable officer holding such position would have.

“Law” means any federal, state, local or foreign law (including common law), statute, code, ordinance, rule, regulation, order, judgment, writ, stipulation, award, injunction, decree, arbitration award or finding or any other legally enforceable requirement.

“Leased Real Property” has the meaning set forth in Section 2.19(a).

“Letter of Intent” has the mean set forth in the definition of Purchased Aircraft.

“Liability” means any liability, debt, loss, damage, claim, cost, expense or obligation of any nature (including costs of investigation and defense and attorney’s fees, costs and expenses), in each case, whether direct or indirect, known or known and whether absolute, accrued or contingent or otherwise.

“Licensed Intellectual Property” has the meaning set forth in Section 2.15(c).

“Lien” means any lien, mortgage, pledge, conditional or installment sale agreement, encumbrance, restriction, charge, option, lease, right of first refusal, right of first offer, easement, security interest, deed of trust, right-of-way, encroachment, community property interest or other claim or restriction of any nature, whether voluntarily incurred or arising by operation of Law (including any restriction on the voting of any security, any restriction on the transfer of any security or other asset, and any limitation or restriction on the possession, exercise or transfer of any other attribute of ownership of any asset).

“Made Available” means that such information, document or material was made available for review by Buyer or Buyer’s Representatives, in each case, two (2) days prior to the date hereof.

“Material Adverse Effect” means any event, change, circumstance, condition, fact, development, occurrence, effect or other matter, other than in the Ordinary Course of Business, that has a material adverse effect on (a) the business, financial condition or financial results of operations of the Company taken as a whole or (b) the ability of Seller to perform its obligations hereunder, including to consummate timely the transactions contemplated by this Agreement; *provided, however*, that none of the following, either alone or in combination, will constitute, or be considered in determining whether there has been, a Material Adverse Effect: any event, change, circumstance, condition, fact, development, occurrence, effect or other matter resulting from or related to (i) any outbreak or escalation of war or major hostilities or any act of terrorism, (ii) any natural or man-made disaster or acts of God, including hurricanes, tornadoes, floods, earthquakes, rain, snow, ice, wind or other natural causes, (iii) changes in Laws, GAAP or enforcement or interpretation thereof after the date hereof, or changes in political, legislative or regulatory conditions, (iv) changes that generally affect the industries and markets in which the Company operates, (v) changes in the financial, credit, securities, or banking markets, or general economic, regulatory or political conditions (including prevailing interest rates, availability of financing, exchange rates, securities markets, commodity prices and fuel costs), (vi) any failure, in and of itself, of the Company to meet any published or internally prepared projections, budgets, plans or forecasts of revenues, earnings or other financial performance measures or operating statistics (it being understood that the facts and circumstances underlying any such failure that are not otherwise excluded from the definition of a “Material Adverse Effect” may be considered in determining whether there has been a Material Adverse Effect), (vii) any change resulting from actions taken by the Company prior to Closing that were expressly approved by the Buyer in writing, (viii) any labor strike or organized labor slowdown or work stoppage, (ix) any increase in competition in any market in which the Company operates, (x) any change in employee base due to Company action approved by Buyer in writing, (xi) any change that is cured by the Seller or the Company prior to the Closing provided such cure, if it involves the creation of a material Liability, was consented to by Buyer (such consent not to be unreasonably withheld), and (xii) the negotiation, execution or delivery of this Agreement, the consummation of the transactions contemplated by this Agreement, the identity of Buyer, or the public announcement or other publicity with respect to any of the foregoing, including any adverse change in employee, union, customer, supplier or similar relationships resulting therefrom; *provided, further*, that, with respect to each of clauses (i), (ii), (iv), (v), (viii) and (ix) above, any such event, change, circumstance, condition, fact, development, occurrence, effect or other matter shall only be disregarded and not taken into account in determining whether a Material Adverse Effect has occurred to the extent that such event, change, circumstance, condition, fact, development, occurrence, effect or other matter does not have a materially disproportionate effect on the Company, relative to other participants, similar in size to the Company and in the industry in which the Company participates.

“Material Contract” has the meaning set forth in Section 2.12(a).

“Material Intellectual Property” has the meaning set forth in Section 2.15(c).

“Net Working Capital Amount” means the Company’s current assets, less the Company’s current liabilities, in each case, calculated in accordance with the Accounting Principles, as of the Adjustment Time. Attached hereto as Appendix A, for illustrative purposes only, is the calculation of the Net Working Capital Amount as if Closing had occurred on October 1, 2017. For the avoidance of doubt, the Net Working Capital Amount shall not include any amounts included in Closing Cash, Company Debt or Unpaid Transaction Expenses.

“Notice of Disagreement” has the meaning set forth in Section 1.4(d)(ii).

“Objection Notice” has the meaning set forth in Section 1.4(d)(i).

“Order” has the meaning set forth in Section 2.13(c).

“Ordinary Course of Business” means within the normal commercial customs and historical usages of the Company, consistent with past practice.

“Organizational Documents” means, for each of Seller and the Company, their respective articles of organization, bylaws, member and/or operating agreement.

“Owned Intellectual Property” has the meaning set forth in Section 2.15(b).

“Parent” has the meaning set forth in the opening paragraph of this Agreement.

“Payoff Lenders” has the meaning set forth in Section 4.12.

“Payoff Letters” has the meaning set forth in Section 4.12.

“Permits” means permits, licenses, certifications, approvals, registrations, consents, authorizations, franchises, variances, exemptions, waivers, orders, takeoff and landing authorizations (including “slots” or “gates” at United States and foreign airports) and clearances required, issued or granted by the FAA, the DOT, the FCC or any other Governmental Entity applicable to it necessary to conduct its business as presently conducted.

“Permitted Company Debt” means the Company’s capital lease obligations.

“Permitted Liens” means (a) Liens for Taxes not yet due and payable or that are being contested in good faith by appropriate proceedings and, if required by GAAP, for which adequate reserves have been established in the most recent financial statements of Seller, (b) Liens in favor of vendors, carriers, warehousemen, repairmen, mechanics, workmen, materialmen, construction or similar liens or other encumbrances arising by operation of Law that are not yet due and payable or that are being contested in good faith by appropriate proceedings and, if required by GAAP, for which adequate reserves have been established in the most recent financial statements of Seller and (c) Liens that do not materially detract from the value or materially interfere with any present or intended use of such property or assets.



“Person” means an individual, corporation, limited liability company, partnership, association, trust, unincorporated organization, other entity or group (as defined in Section 13(d) of the Exchange Act).

“Personal Information” has the meaning set forth in Section 2.15(g).

“Post-Closing Additions” and “Post-Closing Net Addition” has the meaning set forth in Section 1.4(b).

“Post-Closing Reductions” and “Post-Closing Net Reduction” has the meaning set forth in Section 1.4(b).

“Pre-Closing Period” has the meaning set forth in Section 4.1(a).

“Pre-Closing Tax Period” has the meaning set forth in Section 4.6(a).

“Privacy Policy” has the meaning set forth in Section 2.15(g).

“Proceedings” has the meaning set forth in Section 2.12(a)(xx).

“Purchase Price” has the meaning set forth in Section 1.3(a).

“Purchase Price Elements” has the meaning set forth in Section 1.4(a).

“Purchased Aircraft” means those certain used Boeing 737-800 aircraft (MSN 30706 and 28249) as more fully described in the Letter of Intent dated October 6, 2017 by and between the Company and AerCap Ireland Limited (the “Letter of Intent”).

“Purchased Aircraft Letter of Credit” means the letter of credit used to secure the Company’s obligation to acquire the Purchased Aircraft. Immediately upon the payoff of the Company Debt at Closing, the Buyer will cause the Company to enter into a replacement letter of credit or take such other action as AerCap Ireland Limited requires in order to secure the Company’s continuing obligations under the Letter of Intent or applicable purchase agreement concerning the Company’s purchase of the Purchased Aircraft.

“Real Property Leases” has the meaning set forth in Section 2.19(a).

“Registered Intellectual Property” has the meaning set forth in Section 2.15(a).

“Related Party Loan Payable” means all loans, notes, or similar debt obligations owed by the Company to Seller, Seller’s members or any other Affiliate of Seller. Related Party Loan Payable does not include lease payments or other expenses payable to Affiliates of Seller that arise in the Ordinary Course of Business.

“Related Party Loan Receivable” means all loans, notes, or similar debt obligations due to the Company from Seller, Seller’s members or any other Affiliate of Seller.

“Release” means any spill, emission, discharge, leaking, pumping, injection, dumping, disposal, discharge, or leaching into the environment.

“Representatives” has the meaning set forth in Section 4.2(a).

“Resolution Period” has the meaning set forth in Section 1.4(d)(ii).

“Sale Bonuses” has the meaning set forth in the definition of Unpaid Transaction Expenses.

“Sanctioned Person” means at any time any Person: (a) listed on any Sanctions-related list of designated or blocked persons; (b) resident in, or entity organized under the laws of, a country or territory that is the subject of comprehensive restrictive Sanctions (including without limitation Cuba, Iran, North Korea, Sudan, Syria, and the Crimea region); or (c) majority-owned or controlled by any of the foregoing.

“Sanctions” means economic or financial sanctions or trade embargoes imposed, administered or enforced from time to time by: (a) the U.S. government, including without limitation those administered by the U.S. Treasury, Office of Foreign Assets Control, (b) the European Union and implemented by its member States, (c) the United Nations Security Council, or (d) Her Majesty’s Treasury of the United Kingdom.

“SEC” means the United States Securities and Exchange Commission.

“Securities Act” means the Securities Act of 1933, as amended.

“Seller” has the meaning set forth in the opening paragraph of this Agreement.

“Seller Affiliate Support Agreement” means an agreement, in form and substance reasonably acceptable to Buyer and Seller, by and among Seller, its members and affiliated companies and Buyer providing for (a) restrictions on the solicitation and hiring of the Company’s employees by Seller, its members and affiliated companies, (b) confidentiality obligations with respect to non-public information of or regarding the Company and the Transaction Documents, (c) non-disparagement obligations and (d) release of claims against the Buyer Parties and their Affiliates (including the Company from and after the Closing) to the extent such releases are not made pursuant to the mutual release to be delivered pursuant to Section 5.2(e).

“Seller Disclosure Schedule” has the meaning set forth in the introductory paragraph to Article II.

“Seller Tax Matter” has the meaning set forth in Section 4.7(a).

“Software” means computer software and programs in any form and all versions, updates, corrections, enhancements and modifications thereof, and including all source code, object code, specifications, designs and documentation related thereto.

“Straddle Period” has the meaning set forth in Section 4.6(c).

“Subsidiaries” means an affiliate controlled by such person, directly or indirectly, through one or more intermediaries.

“Target Cash Amount” means \$50,000,000.

“Target Debt Amount” means \$10,248,163, which represents the forecasted balance of the Company’s capital lease obligations (includes both short-term and long-term portions) as of December 31, 2017.

“Target Working Capital Amount” means \$700,000.

“Tax Contest” has the meaning set forth in Section 4.7(a).

“Tax Return” means any report, return (including information return), claim for refund or declaration filed with any Governmental Entity with respect to Taxes, including any schedule or attachment thereto, and including any amendments thereof.

“Taxes” means (i) any and all taxes (together with any and all interest, penalties and additions thereto) imposed by any Governmental Entity, including income, franchise, windfall or other profits, gross receipts, property, sales, use, net worth, capital stock, payroll, employment, social security, workers’ compensation, unemployment compensation, fuel, transportation, aviation, excise, withholding, ad valorem, stamp, transfer, value-added, escheat and gains tax, (ii) any and all liability for the payment of any items described in clause (i) above as a result of being (or ceasing to be) a member of an affiliated, consolidated, combined, unitary or aggregate group (or being included (or being required to be included) in any Tax Return related to such group and (iii) any and all liability for the payment of any amounts as a result of any express or implied obligation to indemnify any other person (other than customary provisions for Taxes contained in credit, lease or other commercial agreements the primary purpose of which does not relate to Taxes) or any successor or transferee liability, in respect of any items described in clause (i) or (ii) above.

“Taxing Authority” means any Governmental Entity exercising any authority to determine, impose, regulate, collect, levy, assess, enforce or administer any Tax.

“Third Party” mean any Person or “group” as defined under Section 13(d) of the Exchange Act of Persons, other Seller, the Company or their respective Affiliates or Representatives.

“Trade Secrets” means trade secrets and other rights in know-how and confidential or proprietary information deriving economic value from the secret nature of the information (including any business plans, designs, technical data, customer data, financial information, pricing and cost information, bills of material, or other similar information).

“Transaction Documents” means, collectively, this Agreement, and any certificates delivered in connection with this Agreement, the Escrow Agreement, the Seller Affiliate Support Agreement, the IP License Side Letter, the Affiliate Lease Amendment and the Transition Services Agreement.

“Transition Services Agreement” has the meaning set forth in Section 4.13(b).

“Treasury Regulations” means regulations promulgated by the United States Department of the Treasury under the Code.

“TSA” has the meaning set forth in Section 2.5(b).

“Units” has the meaning set forth in the Recitals.

“Unpaid Transaction Expenses” means, to the extent not paid as of the Adjustment Time, all fees and expenses incurred and payable by the Company in connection with the negotiation and drafting of this Agreement and the pursuit of the transactions contemplated herein, including (i) such fees as may be owed by the Company to Barclays PLC, the Company’s independent accountants, Briggs and Morgan, P.A., Dorsey & Whitney, LLP, Garofalo Goerlich & Hainbach PC and/or Jones Day, LLP, in each case only to the extent such fees relate to this Agreement and/or the transactions contemplated herein and specifically does not include fees related to other services such parties may have provided to the Company unrelated to this Agreement and the transactions contemplated hereby, (ii) all unpaid change of control or transaction bonuses, severance or success or retention or other similar payments of Seller or the Company, in each case arising from or incurred in connection with the consummation of the transactions contemplated by this Agreement, either alone or in combination with any other event (whether paid on or following the Closing) to any current or former officer, director, employee or consultant or independent contractor of Seller or the Company including any requirement to pay related costs or fees and to pay any gross up or make whole for income or excise Taxes imposed with respect to such amounts (all such amounts, “Sale Bonuses”), (iii) the employer’s portion of the withholding or payroll Taxes in respect of the payment of any Sale Bonuses, (iv) half of the premiums, underwriting and other related costs payable in respect of the D&O Insurance, (v) half of all filing fees and other charges in connection with the filing under the HSR Act pursuant to Section 4.4(a) and (vi) half of the premiums, underwriting and other related costs payable, but Seller’s portion not to exceed \$523,575, in respect of the representations and warranties insurance policy, if any, to be purchased by Buyer with respect to this Agreement.

“Unresolved Matter” has the meaning set forth in Section 1.4(d)(iii).

*[Remainder of page intentionally left blank]*

IN WITNESS WHEREOF, Seller, Parent and Buyer have caused this Agreement to be signed by their respective officers thereunto duly authorized as of the date first written above.

**SELLER:**

**MINNESOTA AVIATION, LLC**

By: /s/ James T. Ward

Name: James T. Ward

Its: Chief Financial Officer

*[Signature Page to Membership Interest Purchase Agreement]*

---

**PARENT:**  
**SCA ACQUISITION HOLDINGS, LLC**

By: /s/ Laurie D. Medley  
Name: Laurie D. Medley  
Its: Vice President

**BUYER:**  
**SCA ACQUISITION, LLC**

By: /s/ Laurie D. Medley  
Name: Laurie D. Medley  
Its: Vice President

*[Signature Page to Membership Interest Purchase Agreement]*

---

**APPENDIX A**

ACCOUNTING PRINCIPLES; NET WORKING CAPITAL CALCULATION AND TARGET  
WORKING CAPITAL AMOUNT

See Attached.

---

**APPENDIX B**

COMPANY GROWTH PLAN

See Attached.



---

**APPENDIX C**

**FORM OF IP LICENSE SIDE LETTER**

See Attached.

---

**APPENDIX D**

TERMS OF AFFILIATE LEASE AMENDMENT

See Attached.

**CERTIFICATE OF CONVERSION**  
PURSUANT TO SECTION 265 OF  
THE DELAWARE GENERAL CORPORATION LAW

This Certificate of Conversion is being duly executed and filed by SCA Acquisition Holdings, LLC, a Delaware limited liability company (the "Company"), to convert the Company to Sun Country Airlines Holdings, Inc., a Delaware corporation (the "Corporation"), under the Delaware Limited Liability Company Act (6 Del. C. § 18-101, et seq.) and the Delaware General Corporation Law (8 Del. C. § 101, et seq.).

1. The Company was formed on December 8, 2017 as a Delaware limited liability company.
2. The name and type of entity of the Company immediately prior to filing this Certificate of Conversion is SCA Acquisition Holdings, LLC, a Delaware limited liability company.
3. The name of the Corporation as set forth in the Certificate of Incorporation filed in accordance with Section 265(b) of the Delaware General Corporation Law is Sun Country Airlines Holdings, Inc.
4. The conversion of the Company to the Corporation shall be effective at the time of this filing.

*[Remainder of Page Intentionally Left Blank]*



Certain identified information has been excluded from this exhibit because it is both (i) not material and (ii) would be competitively harmful if publicly disclosed. [\*\*\*] indicates that information has been redacted.

*Execution Copy*

THIS WARRANT AND THE SECURITIES ISSUABLE UPON THE EXERCISE HEREOF HAVE NOT BEEN REGISTERED UNDER THE SECURITIES ACT OF 1933, AS AMENDED (THE “**SECURITIES ACT**”), OR ANY STATE SECURITIES OR BLUE SKY LAWS, AND MAY NOT BE SOLD, DISTRIBUTED, ASSIGNED, OFFERED, PLEDGED, OR OTHERWISE TRANSFERRED UNLESS SUCH TRANSACTION IS REGISTERED OR EXEMPT FROM REGISTRATION UNDER THE SECURITIES ACT OR APPLICABLE STATE SECURITIES OR BLUE SKY LAWS.

Issue Date: December 13, 2019

**SCA ACQUISITION HOLDINGS, LLC  
WARRANT TO PURCHASE SHARES**

This Warrant is issued to Amazon.com NV Investment Holdings LLC (the “**Holder**”) by SCA Acquisition Holdings, LLC (the “**Company**”). The Holder is entitled to exercise this Warrant to purchase equity of the Company (the “**Warrant Shares**”) as more particularly described in **Exhibit A** hereto (the “**Schedule of Terms**”), on the terms provided herein and in the Schedule of Terms. The Warrant Shares will vest and become exercisable in accordance with the vesting terms provided in the Schedule of Terms, and this Warrant is non-forfeitable with respect to vested Warrant Shares.

**1. Exercise of Warrant**

**1.1 Exercise Period.** This Warrant may be exercised by the Holder, in whole or in part, at any time during the Exercise Period (as defined in the Schedule of Terms); provided, however, that if such exercise would result in the Holder acquiring beneficial ownership of Warrant Shares (together with all other equity of the Company owned by the Holder at such time) with a value of or in excess of the Hart-Scott-Rodino Antitrust Improvements Act of 1976, as amended (the “**HSR Act**”), notification threshold applicable to the Holder (the “**HSR Threshold**”), and no exemption to filing a notice and report form under the HSR Act is applicable, then only such portion of this Warrant, which when exercised does not exceed the HSR Threshold, shall be exercised and the applicable Notice of Exercise shall be deemed to relate only to such portion of this Warrant, and the exercise of the remaining portion of this Warrant in excess of the HSR Threshold shall not occur until the expiration or early termination of the applicable waiting periods or receipt of applicable approval. The Exercise Period will be stayed during any waiting period imposed by the HSR Act or any other applicable antitrust or competition law.

**1.2 Method of Exercise.** The Holder may exercise this Warrant by delivering to the Company (a) this Warrant, (b) the Notice of Exercise attached as **Exhibit B** hereto, duly executed by the Holder, indicating whether the Holder elects to purchase Warrant Shares for cash or if the Holder elects to exercise on a net issuance basis and (c) if the Holder is not then a party thereto, a joinder to the Company’s Amended and Restated Limited Liability Company Agreement, as may be amended and restated from time to time (the “**Company LLCA**”) and Amended and Restated Stockholders’ Agreement, as may be amended and restated from time to time (the “**Company SHA**”); provided, that (a) the Holder shall not be bound by or subject to any term in the Company LLCA and/or the Company SHA that would (i) in any way, directly or indirectly, restrict, limit, impair, or restrain, or impose any requirement in respect of, the conduct and operation of the businesses of Amazon.com, Inc. or its affiliates, or permit any restriction, limitation, impairment, or restraint on, or the imposition of any requirement in respect of, the conduct and operation of the businesses of Amazon.com, Inc. or its affiliates, (ii) restrict the Holder from transferring any Warrant Shares to Amazon.com, Inc. or any of its affiliates or (iii) result in the grant of any proxy or power of attorney by the Holder, and (b) in the event that the Company LLCA or Company SHA contains a come-along or drag-along right with respect to a sale of the Company binding on the Holder with respect to its Warrant Shares, such come-along or drag-along right shall be subject to the following requirements: (1) all Warrant Shares held by the Holder are entitled to receive the same form and amount of consideration with respect to such shares upon consummation of the proposed transaction (the “**Drag-Along Transaction**”) as all other holders of shares of the same class as the Warrant Shares are entitled to receive with respect to their shares upon consummation of the Drag-Along Transaction; (2) any representations and warranties to be made by the Holder in connection with the Drag-Along Transaction are limited to representations and warranties related to authority, ownership of the Warrant Shares held by the Holder and the ability to convey title to such Warrant Shares; (3) the Holder shall not be required to enter into any indemnity agreement or otherwise be liable for the inaccuracy or breach of any representation or warranty made by any other person in connection with the Drag-Along Transaction (except for payments from an escrow covering such breach or inaccuracy by (A) the Company or (B) other shareholders of the Company with respect to identical representations and warranties provided by all shareholders), and the Holder’s aggregate liability in connection with the Drag-Along Transaction is pro rata in proportion to, and does not exceed, Holder’s net proceeds actually received in such Drag-Along Transaction; (4) the Holder shall not be required to enter into any covenant, obligation, or release, except, in the case of a release, solely to the extent the release is limited to claims arising in the Holder’s capacity as a stockholder of the Company; (5) the Drag-Along Transaction shall have been approved by the Board (as defined below); (6) all other equityholders of the Company are required to participate in such Drag-Along Transaction or shall have agreed to participate in such Drag-Along Transaction, in each case on terms no more beneficial to them than those set forth in this Section 1.2; and (7) the Company shall have complied with its obligations under the section titled “Right of First Notice” in the Schedule of Terms.

**1.3 Cash Exercise.** If the Holder elects to exercise this Warrant to purchase Warrant Shares for cash, the Holder will make payment by check or wire transfer, in the amount of the Exercise Price (as defined in the Schedule of Terms, subject to adjustment as provided herein) multiplied by the number of Warrant Shares for which this Warrant is being exercised. The Exercise Price is the product of an arms'-length negotiation and is intended to reflect the present fair market value of the Warrant Shares.

**1.4. Net Issuance.** If the Holder elects to exercise this Warrant on a net issuance basis, the Holder will not be required to make a cash payment, and the Company will issue to the Holder a number of Warrant Shares computed using the following formula:

$$X = \frac{(A - B) \times C}{A} \quad \text{where:}$$

X = the number of Warrant Shares to be issued to the Holder;

A = the Fair Market Value of one Warrant Share on the date of net issuance exercise;

B = the Exercise Price (as adjusted to the date of such calculation); and

C = the number of Warrant Shares issuable under this Warrant or, if only a portion of this Warrant is being exercised, the number of Warrant Shares as to which the Holder elects to exercise.

## **2. Delivery of Certificates; No Fractional Shares**

Within five days after exercise of this Warrant, the Company will at its expense issue and deliver to the Holder (a) a certificate or certificates for the number of Warrant Shares to which the Holder is entitled upon such exercise or, if the Company does not issue certificates for its securities, an electronic certificate or other evidence of the valid issuance of the number of Warrant Shares to which the Holder is entitled upon such exercise, and (b) if applicable, a new warrant with terms identical to this Warrant to purchase that number of Warrant Shares as to which this Warrant has not been exercised. The Holder will for all purposes be deemed to have become the holder of record of such Warrant Shares on the date this Warrant is exercised, irrespective of the date of delivery of certificate(s) representing the Warrant Shares. No fractional shares or scrip will be issued upon the exercise of this Warrant. In lieu of a fractional share or scrip, the Company will pay the Holder an amount in cash equal to the Fair Market Value of the fractional share on the date of exercise.

## **3. Representations, Warranties, and Covenants**

**3.1** The Company represents and warrants that it is duly organized, validly existing, and in good standing under the laws of its jurisdiction of formation. Assuming the accuracy of the representations of the Holder under Section 9, the Company represents and warrants that all corporate actions, approvals, and consents on the part of the Company, its officers, directors, equityholders, and any third party, necessary for the sale and issuance of this Warrant and the Warrant Shares have been taken, including the reservation of sufficient Warrant Shares.

**3.2** The Company represents and warrants that the capitalization table attached as *Exhibit C* hereto accurately and completely reflects the Company's authorized and issued equity capital as of the Issue Date. All of the outstanding shares of equity of the Company have been duly authorized, are fully paid and nonassessable, and were issued in compliance with applicable law.

**3.3** The Company covenants that at all times during the Exercise Period there will be reserved for issuance such number of shares as is necessary for exercise in full of this Warrant. All Warrant Shares issued pursuant to the exercise of this Warrant will, upon their issuance, be validly issued and outstanding, fully paid and nonassessable, free and clear of all liens and other encumbrances or restrictions on sale, and free and clear of all preemptive rights, and such Warrant Shares will be issued free from all taxes, liens, and charges with respect to the issuance thereof.

**3.4** The Company will not, directly or indirectly, by charter amendment or by reorganization, sale or transfer of assets, consolidation, merger, dissolution, issuance or sale of securities, or any other voluntary action (excluding for this purpose ordinary course operation of the Company's business), (a) except as otherwise permitted by the terms of this Warrant, avoid or seek to avoid the observance or performance of any of the terms of this Warrant, but will at all times and in good faith assist in the carrying out of all such terms and in the taking of all such action as may be necessary or appropriate in order to protect the rights and interests of the Holder against impairment, or (b) take any action which is adverse to the rights and interests granted to the Holder in this Warrant without making appropriate provision to preserve such rights and interests or otherwise conflicts with the provisions hereof in a manner adverse to the Holder. The Company will not amend the Warrant Agreement, dated as of April 11, 2018, by and between the Company and AP VIII (SCA Warrant AIV), L.P. in a manner that is adverse to the rights and interests granted to the Holder in this Warrant without making appropriate provision to preserve such rights and interests.

## **4. Certain Events**

**4.1 Change of Control.** Subject to, for the avoidance of doubt, the Schedule of Terms, in the event of (i) a Change of Control (as defined below) or (ii) a Significant Minority Event during the Exercise Period in which the consideration to be received by the Company or the stockholders of the Company, as the case may be, consists solely of cash (a "*Cash Sale*") and at the time of such Change of Control or Significant Minority Event the Holder has not exercised this Warrant in full prior to consummation of such Cash Sale, and if the Fair Market Value of one Warrant Share (as of the closing date of such Cash Sale) is greater than the Exercise Price, then, in the case of such a Change of Control, or in the case of such a Significant Minority Event at the election of the Holder in its sole

discretion (it being understood that any such election shall apply only to such Significant Minority Event and not to any other Change of Control or Significant Minority Event), this Warrant will be deemed automatically exercised with respect to each vested Warrant Share (including any Warrant Shares that vest immediately prior to the consummation of such Cash Sale in accordance with the Schedule of Terms) pursuant to a net issuance exercise under Section 1.4 (even if not surrendered) immediately before the consummation of such Cash Sale, and the Holder shall have the right to receive a portion of the proceeds payable in the Cash Sale equal to the amount payable to holders of the same number and class of shares as the Holder is entitled to receive pursuant to such exercise. This Warrant will automatically terminate (without relieving the Company or its successor of any obligations arising from a prior breach or non-compliance) with respect to such vested Warrant Shares following the payment of the amounts due to the Holder in connection with such Cash Sale. If any Warrant Shares are not vested at the consummation of any Cash Sale (taking into account any Warrant Shares that vest immediately prior to the consummation of such Cash Sale), and if the Fair Market Value of one Warrant Share (as of the closing date of such Cash Sale) is greater than the Exercise Price, then the Company will cause the acquiring, surviving, or successor person to assume the obligations of this Warrant with respect to such then-unvested Warrant Shares, and this Warrant will thereafter be exercisable with respect to such then-unvested Warrant Shares for securities of the acquiring, surviving, or successor person (and in any such case, appropriate adjustment shall be made in the application of the provisions of this Warrant with respect to the rights and interests of the Holder after such Cash Sale such that the provisions of this Warrant shall be applicable after that event, as near as reasonably may be, in relation to any securities deliverable after that event upon the exercise of this Warrant) and any reference herein to "Warrant Shares" shall include any other securities of the acquiring, surviving or successor person. If there is a Change of Control during the Exercise Period in which the consideration to be received by the stockholders of the Company consists of securities or other non-cash property (such Change of Control, a "**Non-Cash Sale**"), then the Company will cause the acquiring, surviving, or successor person to assume the obligations of this Warrant, and this Warrant will thereafter be exercisable for the same securities or other property that a holder of the same class of shares as the Warrant Shares would have been entitled to receive in connection with such transaction if such holder held the same number of shares as were purchaseable under this Warrant if this Warrant had been exercised immediately before the consummation of such Non-Cash Sale, subject to further adjustment from time to time in accordance with the provisions of this Warrant. For purposes of this Warrant, the term "**Significant Minority Event**" means any transaction or series of related transactions in which 30% or more of the Company's voting power is transferred to a person or group (within the meaning of the Exchange Act) other than the Company's equityholders or their affiliates immediately prior to such transaction or series of transactions.

#### 4.2. Listing Event.

(a) In the event that the Company undertakes a Listing Event (as defined below), the Company will provide the Holder with notice prior to filing or submitting a registration statement (including a draft registration statement) that includes disclosure of beneficial owners of the Company's equity in connection with a Listing Event (a "**Listing Event Notice**"). The Listing Event Notice must be provided at least 14 days prior to the earlier of (i) the "as of" date used by the Company for disclosure of beneficial owners and (ii) the date on which a Listing Event occurs.

(b) In the event that the Company determines that this Warrant or the terms hereof are required to be disclosed in connection with the Listing Event, the Company will provide the Holder with prompt written notice and an opportunity to comment on the proposed disclosure before such disclosure is made and, if reasonably requested by the Holder, will use commercially reasonable efforts (in cooperation with the Holder) to redact, seek a protective order or confidential treatment, or take other appropriate action to avoid such disclosure.

(c) Notwithstanding anything in this Warrant to the contrary: (i) from and after Holder's receipt of a Listing Event Notice properly provided pursuant to Section 4.2(a), the Company will not honor any exercise of this Warrant, and the Holder will not have the right to exercise any portion of this Warrant, to the extent that, after giving effect to an attempted exercise set forth on the applicable Notice of Exercise, the Holder (or any of its affiliates and other persons whose beneficial ownership of the relevant securities would be aggregated with Holder's for purposes of Section 13(d) or Section 16 of the Exchange Act) would beneficially own in excess of 4.999% of any class of voting equity securities subject to the Exchange Act, calculated in accordance with Section 13(d) of the Exchange Act and the related rules and regulations and after giving effect to the exercise of this Warrant; (ii) none of the limitations of clause (i) will be taken into account when determining the amount of securities or other non-cash property subject to the assumed Warrant or the amount of cash the Holder is entitled to receive in the event of a Change of Control or Significant Minority Event; (iii) if a Listing Event Notice is not properly provided, the limitations of clause (i) will go into effect immediately prior to the "as of" date used by the Company for disclosure of beneficial owners in any registration statement; (iv) the provisions of this sentence should be construed and implemented in a manner otherwise than in strict conformity with the terms of this sentence to correct this sentence (or any portion hereof) which may be defective or inconsistent with the intended beneficial ownership limitation of clause (i) or to make changes or supplements necessary or desirable to properly give effect to such limitation; and (v) the limitations in clause (i) may be waived or amended by the Holder, in its sole discretion, upon written notice to the Company, which waiver or amendment will not be effective until the 61st day after such notice is delivered by the Holder to the Company.

(d) In the event that there is an initial public offering or listing of shares on a national or foreign exchange of one of the Company's equityholders, the Company will make appropriate provision so that the Holder will thereafter be entitled to receive, upon exercise of this Warrant, securities of such equityholder (and in any such case, appropriate adjustment shall be made in the application of the provisions of this Warrant with respect to the rights and interests of the Holder such that the provisions of this Warrant shall be applicable after that event, as near as reasonably may be, in relation to any securities deliverable after that event upon the exercise of this Warrant).

**4.3 Automatic Exercise before Expiration.** To the extent this Warrant is not previously exercised as to all of the Warrant Shares issuable hereunder, and if the Fair Market Value of one Warrant Share (at such measurement date) is greater than the Exercise Price, this Warrant will be deemed automatically exercised pursuant to a net issuance exercise under Section 1.4 (even if not surrendered) immediately before its expiration. To the extent this Warrant or any portion thereof is deemed automatically exercised pursuant to this Section, the Company agrees promptly to notify the Holder in writing of the number of Warrant Shares, if any, the Holder is to receive by reason of such automatic exercise.

## 5. Adjustments

**5.1 Reorganization.** Upon any reorganization, reclassification, capital reorganization, or change in the capital stock of the Company (other than a Change of Control transaction covered by Section 4.1) affecting the same class of shares as the Warrant Shares, the Company will make appropriate provision so that the Holder will thereafter be entitled to receive, upon exercise of this Warrant, the number and type of securities or other property that a holder of the same class of shares as the Warrant Shares would have been entitled to receive in connection with such transaction if such holder held the same number of shares as were purchaseable under this Warrant if this Warrant had been exercised immediately before such reorganization, reclassification, reorganization, or change.

**5.2 Adjustments for Stock Splits, Dividends.** If the Company, directly or indirectly, issues any shares of the same class as the Warrant Shares as a stock dividend, or subdivides or combines such class of shares in a stock split, or issues any shares, options, warrants or other securities to the Company's equityholders or their affiliates that are not on arms-length terms, then the Exercise Price in effect before such dividend, subdivision, combination or issuance will be proportionately decreased or increased, as applicable, and the number of Warrant Shares at that time issuable pursuant to the exercise of this Warrant will be proportionately increased or decreased, as applicable. Each adjustment in the number of Warrant Shares issuable will be to the nearest whole share and each adjustment of the Exercise Price will be calculated to the nearest cent. Any adjustment under this Section will become effective at the close of business on the date the subdivision or combination or issuance becomes effective, or as of the record date of such dividend.

**5.3 Anti-Dilution Protection.** If any shares of the same class as the Warrant Shares are entitled, under the Company's constituent documents or any contract to which the Company is a party, to an adjustment in the event of dilutive issuances of equity, then the Warrant Shares will be entitled to the same adjustment.

**5.4 Certificate as to Adjustments.** If any adjustment is required to be made in the Exercise Price or number and type of securities issuable upon exercise of this Warrant, the Company will promptly give written notice to the Holder in the form of a certificate signed by an officer of the Company, setting forth the adjustment in reasonable detail.

## 6. Registration Rights; Information Rights

**6.1 Registration Rights.** All Warrant Shares issuable upon exercise of this Warrant will be subject to customary registration rights to be agreed upon by the Holder, the Company, and, to the extent applicable, the Company's then-existing equityholders, promptly following the initial exercise of this Warrant (and, in any event, prior to consummation of any Listing Event). The Company shall not provide to the Holder any registration rights that are less favorable to the Holder than any registration rights that the Company has provided to any of its other equityholders holding an equal or smaller percentage equity interest in the Company at such time (provided, that all Warrant Shares issuable upon exercise of this Warrant, whether vested or unvested, will be taken into account in the determination of the Holder's equity interest in the Company at such time).

### 6.2 Information Rights.

(a) The Company will deliver to the Holder:

(i) as soon as practicable, and in any event within 90 days, after the end of each fiscal year of the Company, an audited or reviewed consolidated balance sheet of the Company and its subsidiaries and statement of stockholders' equity of the Company, in each case as of the last day of such year, and an audited or reviewed consolidated income statement and statement of cash flows of the Company and its subsidiaries, in each case for the period then ended, along with the notes to the financial statements, prepared in accordance with generally accepted accounting principles in the United States (as applicable);

(ii) as soon as practicable, and in any event within 60 days, after the end of each fiscal quarter of the Company, an unaudited income statement, an unaudited cash flow statement, an unaudited balance sheet, and a statement of stockholder's equity, year to date and as of the end of such fiscal quarter;

(iii) as soon as practicable, and in any event within 30 days, after the consummation of any third party equity financing or any other material change in the equity capitalization of the Company, (A) an updated capitalization table for the Company (similar in format to the capitalization table attached as Exhibit C) as of the closing of such financing event or as of the date of such other material change, and (B) a copy of any amendments to the Company's constituent documents, if applicable.

(iv) as soon as practicable, and in any event within 30 days, after any 409A reports or other similar opinions or reports setting forth a valuation of the Company's equity interests, a copy of such opinion or report or a summary of the valuation set forth therein; and

(v) annual budgets of the Company, but only to the extent that, and at substantially the same time as, annual budgets are delivered to holders of shares of the same class as the Warrant Shares.



(b) On or before February 15th of each calendar year (or otherwise as provided herein), the Company will:

(i) provide such other information relating to the Company or its affiliates (at no out of pocket cost to the Company) as requested by the Holder and as may be reasonably required for the Holder or any of its affiliates to prepare or file any tax return or to prepare such filings with respect to the Company or any of its affiliates as may be required by any tax authority; and

(ii) reasonably cooperate (at no out of pocket cost to the Company) in preparing for any audit of, or dispute with a tax authority regarding any tax return of, the Holder or any of its affiliates relating to the Company or any of its affiliates.

(c) Information received by the Holder pursuant to this Section 6.2 will be used by the Holder and its affiliates for purposes of permitting the Holder and its affiliates to comply with their respective financial reporting and tax obligations (and any similar requirements of any governmental authority) and will be treated as confidential in accordance with the terms of the applicable non-disclosure agreement between the Holder and its affiliates and the Company.

#### **7. Lost or Damaged Warrant Certificate**

Upon receipt by the Company of a letter from the Holder stating loss, theft, destruction, or damage of this Warrant and evidence of indemnity or other security reasonably satisfactory to the Company of the loss, theft, destruction, or damage, the Company will execute and deliver to the Holder, without charge, a new warrant with identical terms as this Warrant.

#### **8. Notices of Record Date, etc.**

In the event of any corporate action requiring the Company to establish a record date for its stockholders, the Company will mail to the Holder, at least 14 calendar days prior to the earlier of the record date or such corporate action, a written notice specifying (a) the date on which any such event is to occur or such record is to be taken, (b) the amount and character of any stock or other securities, or rights or warrants, proposed to be issued or granted, the date of such proposed issuance or grant, and the persons or class of persons to whom such proposed issuance or grant is to be offered or made, and (c) in reasonable detail, the facts, including the proposed date, concerning any other such event.

#### **9. Investment Intent**

By accepting this Warrant, the Holder represents that it (a) is acquiring this Warrant for investment and not with a view to, or for sale in connection with, any distribution or public offering thereof within the meaning of the Securities Act, (b) understands that this Warrant and the Warrant Shares subject to this Warrant have not been registered under the Securities Act by reason of their issuance in a transaction exempt from the registration requirements of the Securities Act pursuant to Section 4(a)(2) thereof and may be transferred only in compliance with the registration requirements of the Securities Act or pursuant to an exemption therefrom, and (c) is an “accredited investor” as such term is defined in Rule 501 of Regulation D under the Securities Act.

#### **10. Miscellaneous**

##### **10.1 Certain Definitions.** For purposes of this Warrant:

(a) “*affiliate*” means, as to any person, any person that directly or indirectly controls, is controlled by, or is under common control with that person.

(b) “*Code*” means the U.S. Internal Revenue Code of 1986, as amended.

(c) “*Change of Control*” means (i) any consolidation, merger, reorganization, or similar transaction involving the Company or its subsidiaries in which the Company’s equityholders and their affiliates immediately prior to such transaction own, immediately after such transaction, less than 50% of the voting securities of the surviving entity, (ii) any transaction or series of related transactions in which 50% or more of the Company’s voting power is transferred to a person or group (within the meaning of the Exchange Act) other than the Company’s equityholders and their affiliates immediately prior to such transaction or series of transactions, or (iii) the sale, lease, exclusive license, or other transfer, in any transaction or series of related transactions, of all or substantially all of the assets of the Company and its subsidiaries.

(d) “*Fair Market Value*” of a Warrant Share means:

(i) if shares of the same class as the Warrant Shares are traded on an exchange or an over-the-counter market, the average of the closing price for the five business days immediately preceding the date of net issuance exercise;

(ii) if the net issuance exercise is in connection with a Change of Control, the value of the consideration to be received pursuant to such Change of Control by the holder of a share of the same class as the Warrant Shares; and

(iii) if neither of the above clauses applies, the Fair Market Value will be the price for a share of the same class as the Warrant Shares that the Company could obtain from an arms’-length buyer who is not a current or former employee, officer, or director of the Company or its affiliates (such price to be exclusive of any control or other similar premium), as determined in good faith by the Company’s board of directors (or equivalent governing body) (the “*Board*”). The Company will promptly provide the Holder a written summary of such determination.

(e) “*Listing Event*” means any of the following: (i) the closing of the Company’s initial public offering of securities pursuant to an effective registration statement filed under the Securities Act in which the securities are listed on a national securities exchange, or the listing of the Company’s shares on a stock exchange outside of the United States; or (ii) the registration of the Company’s securities under Section 12 of the Securities Exchange Act of 1934, as amended (the “*Exchange Act*”), or any successor statute, in connection with its initial public offering, or the occurrence of any other event that results in the Warrant Shares becoming a class of “equity security,” as such term is defined in Rule 13d-1(i) under such Act.

(f) “*person*” means any individual, corporation, partnership, trust, joint venture, limited liability company, association, organization, other entity, or governmental or regulatory authority.

**10.2 No Stockholder Rights or Liabilities.** Prior to exercise, this Warrant will not entitle the Holder to any voting rights or other rights as a stockholder of the Company other than as set forth in this Warrant. In no event will the Holder have any liability hereunder, other than the consideration payable upon exercise of this Warrant pursuant to Section 1.1 hereof.

**10.3 Notices.** Any notice under this Warrant will be given in writing and will be sent by nationally recognized overnight courier service, certified mail (return receipt requested), receipted facsimile, or personal delivery to the other party at the address below. A party may change its notice address by giving notice in accordance with this Section.

If to the Holder:

Amazon.com NV Investment Holdings LLC  
c/o Amazon.com, Inc.  
P.O. Box 81226  
Seattle, WA 98108-1226  
Fax: (206) 266-7010  
Attn: General Counsel

If to the Company: to the address set forth below  
the Company’s signature at the end of this  
Warrant.

**10.4**

**Amendments and Waivers.** Any term of this Warrant may be amended, and the observance of any term may be waived (either generally or in a particular instance and either retroactively or prospectively), only with the written consent of the Company and the Holder.

**10.5 Governing Law; Severability; Jurisdiction; Venue.** This Warrant will be governed by and construed under the laws of the State of Delaware without regard to principles of conflict of laws. If any Section or provision of this Warrant is found or be held to be illegal, invalid, or unenforceable, the remainder of this Warrant will be valid and enforceable and the parties in good faith will negotiate a substitute, valid, and enforceable provision that most nearly effects the parties’ intent in entering into this Warrant. The parties irrevocably consent to the jurisdiction and venue of the Chancery Court of the State of Delaware (or, if the Chancery Court of the State of Delaware declines to accept jurisdiction, any state or federal court within the State of Delaware) in connection with any action relating to this Warrant.

**10.6 Transfer; Successors and Assigns.** This Warrant and all rights hereunder are transferable by the Holder, (a) in whole or in part, to any affiliate of the Holder, or (b) in whole to any non-affiliate of the Holder with the prior written consent of the Company (not to be unreasonably withheld or delayed), provided that the rights of the Holder described under the headings “Right of First Notice” and “Additional Terms” of the Schedule of Terms are non-transferrable except to an affiliate of the Holder, in each case upon surrender of this Warrant properly endorsed or accompanied by written instructions of transfer attached as *Exhibit D* hereto, and the Company will issue a new warrant reflecting such transfer but otherwise identical to this Warrant. The Company may not assign this Warrant or its obligations under this Warrant without the prior written consent of the Holder. The terms and conditions of this Warrant will inure to the benefit of, and be binding on, the respective successors and permitted assigns of, the Company and the Holder, respectively.

**10.7 Income Tax Treatment.** The parties acknowledge that this Warrant is not being issued in connection with the performance of services within the meaning of Section 83 of the Code, the Holder will control the valuation of this Warrant for all relevant tax purposes, and the issuance of this Warrant represents a closed transaction for income tax purposes. The parties will not take a position on any income tax return inconsistent with the foregoing sentence.

**10.8 Headings; Construction.** The headings in this Warrant are for purposes of reference only and will not limit or otherwise affect the meaning of any provision of this Warrant. The words “include” and “including” will be deemed in each case to be followed by the words “without limitation.”

## **11. Additional Terms**

**11.1 Use of Terms.** All references in this Warrant to “stock” or “shares” will be interpreted to refer to units, membership interests, or limited liability company interests, as applicable with respect to the Company, and all references to “stockholders” will be interpreted to refer to unitholders or interest holders, as applicable with respect to the Company. For the avoidance of doubt, the term “*Warrant Shares*” refers to the number and class of equity as more particularly described in the Schedule of Terms.

**11.2 No Capital Contribution.** In the event that the Holder exercises this Warrant, in whole or in part, the Holder will not be required to make any capital contribution to the Company as a condition of its admission as a member of the Company.

**11.3 Tax Treatment.** The Company represents and warrants that it has made a valid U.S. tax election to be treated as an association taxable as a corporation for U.S. tax purposes and the Company covenants that it will not make a U.S. tax election to be treated as anything other than an association taxable as a corporation without receiving the prior written consent of the Holder, such consent to not be unreasonably withheld.



IN WITNESS WHEREOF, the Company has executed this Warrant as of the date first written above.

**SCA ACQUISITION HOLDINGS, LLC**

**By:** /s/ Jude Bricker  
**Name:** Jude Bricker  
**Title:** CEO

**Company address for notices:**  
2005 Cargo Road, Minneapolis, MN 55450  
Attention: CFO  
with a copy to:  
Attention: General Counsel  
same address as above

[Signature Page to Warrant]

## SCHEDULE OF TERMS OF WARRANT SHARES

Capitalized terms used in this Schedule of Terms have the meanings ascribed to those terms in the Warrant.

<b>Name of Company:</b>	SCA Acquisition Holdings, LLC
<b>Jurisdiction of formation and type of entity:</b>	Delaware limited liability company
<b>Class of equity subject to Warrant:</b>	Common Stock
<b>Number of Warrant Shares (as of Issue Date, assuming full vesting of the Warrant):</b>	502,028
<b>Assumed valuation (as of Issue Date) on a fully diluted, post-exercise basis:</b>	\$715,000,000
<b>Exercise Price (as of Issue Date):</b>	\$286.46 per Warrant Share
<b>Holder's fully diluted ownership percentage of the Company (as of Issue Date, assuming full vesting of the Warrant):</b>	15%
<b>Exercise Period:</b>	From the Issue Date until the 8 <sup>th</sup> anniversary of the Issue Date
<b>Vesting Schedule:</b>	<p>The Warrant Shares will vest and become exercisable on the following schedule:</p> <ul style="list-style-type: none"> <li>• 33,469 Warrant Shares will vest on Issue Date of this Warrant;</li> <li>• [***] Warrant Shares will vest on the date on which the cumulative total amount of fees or other amounts paid to the Company or any of its controlled affiliates by or on behalf of the Holder, Amazon.com, or any of their affiliates (such fees or other amounts, "<b>Payments</b>"; provided that "Payments" will not include reimbursable and direct pass-through expenses (but will include start-up payments and termination payments) pursuant to the Commercial Agreement) equals or exceeds \$[***];</li> <li>• [***] Warrant Shares will vest for each additional incremental \$[***] in cumulative Payments (a "<b>Milestone</b>"), on each date on which a Milestone is achieved. For the avoidance of doubt, all of the Warrant Shares will be vested once the cumulative total amount of Payments equals or exceeds \$1,120,000,000.</li> </ul>

## Acceleration of Vesting:

Any unvested Warrant Shares will become fully vested and immediately exercisable (i) immediately prior to the consummation of any Change of Control (other than a Non-Qualifying Change of Control), (ii) immediately prior to the consummation of any Significant Minority Event (other than a Non-Qualifying Significant Minority Event), or (iii) upon termination of the Commercial Agreement (as defined below) by the Holder, Amazon.com Services, Inc., or any of their affiliates following an “Event of Default” by Sun Country, Inc. pursuant to Section 4.5 thereof on the terms set forth in the Commercial Agreement and subject to any cure periods set out therein, following a Non-Qualifying Change of Control or any Significant Minority Event whereby the ultimate acquirer is a financial sponsor.

Fifty percent (50%) of the then-unvested Warrant Shares will become fully vested and immediately exercisable upon termination of the Commercial Agreement (as defined below) by the Holder, Amazon.com Services, Inc., or any of their affiliates based on Sun Country, Inc.’s failure to maintain required “Arrival Performance” pursuant to Section 4.2.2 thereof on the terms set forth in the Commercial Agreement and subject to any cure periods set out therein, following a Non-Qualifying Change of Control.

For purposes of this Schedule of Terms, a “**Non-Qualifying Change of Control**” means a Change of Control whereby the ultimate acquirer is a financial sponsor (provided that this Warrant remains outstanding as a warrant for a class of equity in the Company or an entity that is a parent company of (or successor, as holding company of the business operated by the Company and its direct or indirect subsidiaries, to) the Company, and in either case, such entity is the sole entity in which investors hold equity and such entity is therefore the relevant entity for any future liquidity event or change of control transaction (as determined by the Holder and the Company in good faith), and such warrant entitles the Holder (or its permitted assignee) to the same rights (including the right to continue to vest Warrant Shares) and includes (as closely as reasonably practicable) the same economic terms and economic interest as are set forth in this Warrant (as determined by Holder and the Company in good faith)), and a “**Non-Qualifying Significant Minority Event**” means (i) any initial public offering or follow-on equity offering by the Company or the Company’s equityholders that are affiliates of Apollo Global Management, Inc. (for the avoidance of doubt, without prejudice to the last sentence of Section 4.2) conducted pursuant to an effective registration statement; provided that no person or group (within the meaning of the Exchange Act) acquires more than 50% of the voting interests of the Company in such initial public offering or follow-on offering or (ii) any Significant Minority Event whereby the ultimate acquirer is a financial sponsor (provided in

each case that this Warrant remains outstanding as a warrant for a class of equity in the Company or an entity that is a parent company of (or successor, as holding company of the business operated by the Company and its direct or indirect subsidiaries, to) the Company, and in either case, such entity is the sole entity in which investors hold equity and such entity is therefore the relevant entity for any future liquidity event or change of control transaction (as determined by the Holder and the Company in good faith), and such warrant entitles the Holder (or its permitted assignee) to the same rights (including the right to continue to vest Warrant Shares) and includes (as closely as reasonably practicable) the same economic terms and economic interest as are set forth in this Warrant (as determined by Holder and the Company in good faith)).

**Commercial Agreement related to Warrant  
(the “Commercial Agreement”):**

Air Transportation Services Agreement, dated as of the date hereof, by and between Sun Country, Inc. and Amazon.com Services, Inc., as the same may be amended, modified, supplemented or replaced from time to time.

**Right of First Notice:**

In the event the Company or the direct or indirect equityholders of the Company propose to initiate a process to explore a Change of Control, or to accept any offer from any person for, or enter into negotiations with any person with respect to, a Change of Control (each such proposed Change of Control, and negotiations with respect thereto, a “**Proposed Sale**”), the Company will provide to the Holder written notice thereof (a “**Sale Notice**”) at least 30 days prior to entering into any definitive agreement or binding letter of intent with respect to such Proposed Sale, stating in reasonable detail the terms and conditions of such Proposed Sale, and the Holder will have the right to enter into non-exclusive, good faith negotiations with the Company and the direct or indirect equityholders of the Company in respect of the Proposed Sale or another similar transaction, and the Company and the direct or indirect equityholders of the Company will not be permitted to enter into any definitive agreement or binding letter of intent with respect to such Proposed Sale before the expiration of such period (such period, as may be extended by the occurrence of an Adverse Change (as defined below), the “**Negotiation Period**”). In the event of any price decrease or other changes to the terms and conditions set forth in the Sale Notice which are materially more favorable to the person making the offer for a Proposed Sale (such decrease or change, an “**Adverse Change**”), the Company and the direct or indirect equityholders of the Company will not be permitted to enter into any definitive agreement or binding letter of intent with respect to such Proposed Sale unless the Company has first provided a new Sale

Notice to the Holder with at least 10 calendar days' advance notice. In the event that the Holder makes an offer with respect to a Proposed Sale or another similar transaction during any period contemplated by this paragraph that the Company and its equityholders do not accept, the Company and its equityholders may only consummate a Proposed Sale with a third party at a price that is greater than that contained in such offer from the Holder. If the Company or its equityholders do not execute a definitive agreement with respect to a Proposed Sale within 6 months of the expiration of the Exclusivity Period, the Company and its equityholders shall be required to again comply with the requirements of this paragraph with respect to a Proposed Sale.

**Additional Terms:**

**Board Director or Observer:**

For so long as the (i) Holder holds the Warrant or any Warrant Shares issued upon exercise of the Warrant and (ii) the Commercial Agreement remains in effect, prior to a Change of Control (other than a Non-Qualifying Change of Control) (it being understood that in connection with any such Change of Control, the Company and the Board shall use commercially reasonable efforts to request the prospective acquirer to continue the Holder's director and observer rights as set forth herein), but subject to any applicable stock exchange or listing rules, the Company agrees that the Holder will have the right, but not the obligation, to designate (or, following a Listing Event, nominate) at the Holder's option (i) an individual to serve on the Board (the "**Holder Director**") or (ii) an individual to attend meetings of the Board (any such individual, a "**Holder Observer**"). The Holder Director will have the same protections and rights as other directors of the Company, including voting rights, indemnification, exculpation, and advancement of expenses. The Holder Observer will have full rights to participate in meetings of the Board as an observer and to receive notice and all materials and information in respect thereof at the same time as members of the Board, but will not have the right to vote at any such meeting or act on behalf of the Board. The Company will reimburse the reasonable out-of-pocket expenses incurred by the Holder Director and/or the Holder Observer in connection with any of the foregoing matters in accordance with the terms of the Company LLCA (if applicable). The Company acknowledges any Holder Observer shall not owe any fiduciary duties or any other similar obligations or duties, including in law or equity, to the Company, its subsidiaries or its stockholders, and may act all times in the best interests of the Holder and its affiliates. The Company shall prepare and provide, or cause to be prepared and provided to the Holder Director and/or the Holder Observer, as applicable, any materials or other



information generally prepared for or given to other members of the Board, as and when prepared for or given to such other members, as well as any other materials or other information relating to the management, operations, and finances of the Company, as and when generally provided to members of the Board or as and when reasonably requested by the Holder Director and/or Holder Observer, as applicable; provided that the failure to deliver or make available one or more of the items described in this sentence to the Holder Observer shall not affect the validity of any action taken by the Board; provided, further, that the Company shall not be required to provide to the Holder Observer any such information, the provision of which the Company determines based on advice from external counsel would reasonably be expected to jeopardize an attorney-client or similar privilege or cause a loss of attorney work product protection (provided, however, that the Company withholds only such portion of the information that is subject to the privilege or protection, and provides the Holder Observer with any portions of such information that would not reasonably be expected to jeopardize an attorney-client or similar privilege or cause a loss of attorney work product protection); provided, further, that the Company will not be obligated to provide access to, or to disclose, and may withhold, and the applicable Holder Director and/or Holder Observer shall not be entitled to attend and otherwise participate in, or observe such meetings or portions thereof if Board determines in good faith that such information (i) relates to the Company's relationship to the Holder and its affiliates under the Commercial Agreement or this Warrant, and (ii) poses a genuine conflict of interest between the Company, on the one hand, and the Holder and its affiliates, on the other.

**Management Meetings:**

From time to time during the Exercise Period, and no less than once per fiscal quarter of the Company, the Company's senior management will meet with representatives of the Holder and its affiliates, at such times and places as are mutually agreed upon by the Holder and the Company, to assess their existing business relationship.

**Additional Issuances of Certain Securities:**

If, at any time prior to the second anniversary of the Issue Date of this Warrant, the Company shall, directly or indirectly, issue or be deemed to have issued (i) any options or warrants to purchase or rights to subscribe for shares of any class of capital stock of the Company, or (ii) any securities or instruments that by their terms are convertible into or exchangeable for shares of any class

of capital stock of the Company, or options or warrants to purchase or rights to subscribe for any such convertible or exchangeable securities or instruments, in each case, to a customer or commercial partner of the Company or its affiliates in connection with such customer or partner relationship (clauses (i) and (ii) collectively, "**Covered Securities**"), then the Company shall not provide to the holder of any such Covered Securities any rights, benefits, or other terms that are more favorable to such holder than the rights, benefits, and terms provided to the Holder under this Warrant unless, in any such case, this Warrant has been amended (or is amended concurrently with the issuance of such Covered Securities) to provide the Holder with such favorable rights, benefits, and terms.

NOTICE OF EXERCISE

To: Company Name: \_\_\_\_\_ (the "*Company*")

Address: \_\_\_\_\_

The undersigned hereby irrevocably elects to exercise the attached Warrant as follows:

- purchase \_\_\_\_\_ Warrant Shares pursuant to the terms of the attached Warrant, for an aggregate purchase price of \$\_\_\_\_\_.
- net issuance exercise with respect to \_\_\_\_\_ Warrant Shares pursuant to the terms of the attached Warrant, for such number of shares of equity of the Company as is determined pursuant to Section 1.4 of the attached Warrant.

The undersigned requests that certificates for such shares be issued in the name of and delivered to the address of the undersigned, at the address stated below and, if such number of shares are not all the shares that may be issued pursuant to the attached Warrant, that a new Warrant evidencing the right to purchase the balance of such shares be registered in the name of, and delivered to, the undersigned at the address stated below.

Balance shares for new Warrant to be issued: \_\_\_\_\_

Dated: \_\_\_\_\_

Name of Holder of Warrant: \_\_\_\_\_  
(please print)

Address: \_\_\_\_\_

Signature: \_\_\_\_\_

## COMPANY CAPITALIZATION AS OF ISSUE DATE

	<u>Authorized Shares</u>	<u>Issued and Outstanding Shares</u>	<u>Fully Diluted Shares</u>	<u>Fully Diluted Ownership %</u>
<b><u>Common Stock:</u></b>				
Total Common Stock	5,000,000	360,009	360,009	<b>10.76%</b>
<b><u>Warrants:</u></b>				
Existing warrant to purchase Common Stock		2,117,991	2,117,991	63.28%
Amazon Warrant		<u>502,028</u>	<u>502,028</u>	<u>15.000%</u>
<b>Total Warrants</b>		<u>2,620,019</u>	<u>2,620,019</u>	<u><b>78.28%</b></u>
<b><u>Equity Incentive Plan:</u></b>				
Vested (time based) Management Options		27,637	27,637	0.83%
Allocated but Unvested Management Options		272,597	272,597	8.14%
Unallocated Management Options		<u>66,594</u>	<u>66,594</u>	<u>1.99%</u>
<b>Total Incentive Plan Shares</b>		<u><b>366,828</b></u>	<u><b>366,828</b></u>	<u><b>10.96%</b></u>
<b>TOTAL</b>				<u><b>100.000%</b></u>

**ASSIGNMENT**

For value received the undersigned sells, assigns and transfers to the transferee named below the attached Warrant, together with all right, title and interest, and does irrevocably constitute and appoint the transfer agent of the Company as the undersigned's attorney, to transfer said Warrant on the books of the Company, with full power of substitution in the premises.

Name of Company: \_\_\_\_\_

Dated: \_\_\_\_\_

Name of Holder of Warrant: \_\_\_\_\_  
(please print)

Address: \_\_\_\_\_

Signature: \_\_\_\_\_

Name of transferee: \_\_\_\_\_  
(please print)

Address of transferee: \_\_\_\_\_

---

PASS THROUGH TRUST AGREEMENT

Dated as of December 9, 2019

between

SUN COUNTRY, INC.

and

WILMINGTON TRUST, NATIONAL ASSOCIATION,

as Trustee

---

## TABLE OF CONTENTS

	Page
ARTICLE I	
DEFINITIONS	
Section 1.01. Definitions	2
Section 1.02. Compliance Certificates and Opinions	10
Section 1.03. Form of Documents Delivered to Trustee	11
Section 1.04. Directions of Certificateholders	11
ARTICLE II	
ORIGINAL ISSUANCE OF CERTIFICATES; ACQUISITION OF TRUST PROPERTY	
Section 2.01. Amount Unlimited; Issuable in Series	13
Section 2.02. Acquisition of Equipment Notes	15
Section 2.03. Acceptance by Trustee	16
Section 2.04. Limitation of Powers	17
ARTICLE III	
THE CERTIFICATES	
Section 3.01. Form, Denomination and Execution of Certificates	17
Section 3.02. Authentication of Certificates	17
Section 3.03. Temporary Certificates	18
Section 3.04. Transfer and Exchange	18
Section 3.05. Book-Entry and Definitive Certificates	19
Section 3.06. Mutilated, Destroyed, Lost or Stolen Certificates	21
Section 3.07. Persons Deemed Owners	21
Section 3.08. Cancellation	21
Section 3.09. Limitation of Liability for Payments	22
ARTICLE IV	
DISTRIBUTIONS; STATEMENTS TO CERTIFICATEHOLDERS	
Section 4.01. Certificate Account and Special Payments Account	22
Section 4.02. Distributions from Certificate Account and Special Payments Account	22
Section 4.03. Statements to Certificateholders	24
Section 4.04. Investment of Special Payment Moneys	25

ARTICLE V

THE COMPANY

Section 5.01.	Maintenance of Corporate Existence	25
Section 5.02.	Consolidation, Merger, Etc	25

ARTICLE VI

DEFAULT

Section 6.01.	Events of Default	26
Section 6.02.	Incidents of Sale of Equipment Notes	28
Section 6.03.	Judicial Proceedings Instituted by Trustee; Trustee May Bring Suit	28
Section 6.04.	Control by Certificateholders	28
Section 6.05.	Waiver of Past Defaults	29
Section 6.06.	Right of Certificateholders to Receive Payments Not to Be Impaired	29
Section 6.07.	Certificateholders May Not Bring Suit Except Under Certain Conditions	30
Section 6.08.	Remedies Cumulative	30
Section 6.09.	Undertaking for Costs	30

ARTICLE VII

THE TRUSTEE

Section 7.01.	Certain Duties and Responsibilities	31
Section 7.02.	Notice of Defaults	31
Section 7.03.	Certain Rights of Trustee	31
Section 7.04.	Not Responsible for Recitals or Issuance of Certificates	32
Section 7.05.	May Hold Certificates	33
Section 7.06.	Money Held in Trust	33
Section 7.07.	Compensation and Reimbursement	33
Section 7.08.	Corporate Trustee Required; Eligibility	34
Section 7.09.	Resignation and Removal; Appointment of Successor	34
Section 7.10.	Acceptance of Appointment by Successor	35
Section 7.11.	Merger, Conversion, Consolidation or Succession to Business	36
Section 7.12.	Maintenance of Agencies	36
Section 7.13.	Money for Certificate Payments to Be Held in Trust	38
Section 7.14.	Registration of Equipment Notes in Trustee's Name	38
Section 7.15.	Representations and Warranties of Trustee	38
Section 7.16.	Withholding Taxes; Information Reporting	39
Section 7.17.	Trustee's Liens	39
Section 7.18.	Capacity in Which Acting	39

ARTICLE VIII

CERTIFICATEHOLDERS' LISTS AND REPORTS BY TRUSTEE



Section 8.01.	The Company to Furnish Trustee with Names and Addresses of Certificateholders	40
Section 8.02.	Preservation of Information; Communications to Certificateholders	40
Section 8.03.	Reports by the Company	40

## ARTICLE IX

### SUPPLEMENTAL AGREEMENTS

Section 9.01.	Supplemental Agreements Without Consent of Certificateholders	41
Section 9.02.	Supplemental Agreements with Consent of Certificateholders	42
Section 9.03.	Documents Affecting Immunity or Indemnity	43
Section 9.04.	Execution of Supplemental Agreements	43
Section 9.05.	Effect of Supplemental Agreements	43
Section 9.06.	Reference in Certificates to Supplemental Agreements	43

## ARTICLE X

### AMENDMENTS TO INDENTURE AND NOTE DOCUMENTS

Section 10.01.	Amendments and Supplements to Indenture and Other Note Documents	44
----------------	--	----

## ARTICLE XI

### TERMINATION OF TRUSTS

Section 11.01.	Termination of the Trusts	45
----------------	---------------------------	----

## ARTICLE XII

### MISCELLANEOUS PROVISIONS

Section 12.01.	Limitation on Rights of Certificateholders	46
Section 12.02.	Liabilities of Certificateholders	46
Section 12.03.	Registration of Equipment Notes in Name of Subordination Agent	46
Section 12.04.	Notices	46
Section 12.05.	Governing Law	47
Section 12.06.	Severability of Provisions	47
Section 12.07.	Effect of Headings and Table of Contents	47
Section 12.08.	Successors and Assigns	47
Section 12.09.	Benefits of Agreement	48
Section 12.10.	Legal Holidays	48
Section 12.11.	Counterparts	48
Section 12.12.	Intention of Parties	48

PASS THROUGH TRUST AGREEMENT

This PASS THROUGH TRUST AGREEMENT, dated as of December 9, 2019 (this “Basic Agreement”), between SUN COUNTRY, INC., a Minnesota corporation (the “Company”), and WILMINGTON TRUST, NATIONAL ASSOCIATION, a national association, as Trustee, is made with respect to the formation from time to time of separate Sun Country Pass Through Trusts, and the issuance from time to time of separate series of Pass Through Certificates representing fractional undivided interests in the respective Trusts.

WITNESSETH:

WHEREAS, from time to time, the Company and the Trustee may enter into one or more Trust Supplements (this and certain other defined terms used herein are defined in Section 1.01) pursuant to which the Trustee shall declare the creation of a separate Trust for the benefit of the Holders of the series of Certificates to be issued in respect of such Trust, and the initial Holders of the Certificates of such series, as the grantors of such Trust, by their respective acceptances of the Certificates of such series, shall join in the creation of such Trust with the Trustee;

WHEREAS, all Certificates to be issued in respect of each separate Trust will be issued as a separate series pursuant to this Agreement, will evidence fractional undivided interests in such Trust and will have no rights, benefits or interests in respect of any other separate Trust or the property held therein, subject, however, to the provisions of any Intercreditor Agreement to which one or more Trusts may be a party;

WHEREAS, from time to time, pursuant to the terms and conditions of this Agreement with respect to each separate Trust formed hereunder, the Trustee on behalf of such Trust shall purchase one or more issues of Equipment Notes having the same interest rate (including, if applicable, on a weighted average basis) as, and final maturity dates not later than the final Regular Distribution Date of, the series of Certificates issued in respect of such Trust and, subject to the terms of any related Intercreditor Agreement, shall hold such Equipment Notes in trust for the benefit of the Certificateholders of such Trust;

WHEREAS, to facilitate the sale of Equipment Notes to, and the purchase of Equipment Notes by, the Trustee on behalf of each Trust created from time to time pursuant to this Agreement, the Company has duly authorized the execution and delivery of this Basic Agreement and each Trust Supplement with respect to all such Certificates and is undertaking to perform certain administrative and ministerial duties hereunder and is also undertaking to pay the fees and expenses of the Trustee; and

NOW, THEREFORE, in consideration of the mutual agreements herein contained, and of other good and valuable consideration the receipt and adequacy of which are hereby acknowledged, the parties hereto agree as follows:

ARTICLE I

DEFINITIONS

Section 1.01. Definitions. For all purposes of this Basic Agreement, except as otherwise expressly provided or unless the context otherwise requires:

(1) the terms used herein that are defined in this Article I have the meanings assigned to them in this Article I, and include the plural as well as the singular;

(2) all references in this Basic Agreement to designated "Articles", "Sections", "Subsections" and other subdivisions are to the designated Articles, Sections, Subsections and other subdivisions of this Basic Agreement;

(3) the words "herein", "hereof" and "hereunder" and other words of similar import refer to this Basic Agreement as a whole and not to any particular Article, Section, Subsection or other subdivision;

(4) unless the context otherwise requires, whenever the word "including", "include" or "includes" is used herein, it shall be deemed to be followed by the phrase "without limitation"; and

(5) the term "this Agreement" (as distinguished from "this Basic Agreement") refers, unless the context otherwise requires, to this Basic Agreement as supplemented by the Trust Supplement creating a particular Trust and establishing the series of Certificates issued or to be issued in respect thereof, with reference to such Trust and such series of Certificates, as this Basic Agreement as so supplemented may be further supplemented with respect to such Trust and such series of Certificates.

Act: Has the meaning, with respect to any Certificateholder, specified in Section 1.04(a).

Affiliate: Means, with respect to any specified Person, any other Person directly or indirectly controlling or controlled by or under direct or indirect common control with such Person. For the purposes of this definition, "control", when used with respect to any specified Person, means the power, directly or indirectly, to direct the management and policies of such Person, whether through the ownership of voting securities or by contract or otherwise, and the terms "controlling" and "controlled" have meanings correlative to the foregoing.

Aircraft: Means one or more aircraft, including engines therefor, owned by or leased to the Company and securing one or more Equipment Notes.

Authorized Agent: Means, with respect to the Certificates of any series, any Paying Agent or Registrar for the Certificates of such series.

Basic Agreement: Means this Pass Through Trust Agreement, as the same may from time to time be supplemented, amended or modified, but does not include any Trust Supplement.

Book-Entry Certificates: Means, with respect to the Certificates of any series, a beneficial interest in the Certificates of such series, ownership and transfers of which shall be made through book entries as described in Section 3.05.

Business Day: Means, with respect to the Certificates of any series, any day other than a Saturday, a Sunday or a day on which commercial banks are required or authorized to close in New York, New York, or, so long as any Certificate of such series is outstanding, the city and state in which the Trustee or any related Loan Trustee maintains its Corporate Trust Office or receives and disburses funds.

Certificate: Means any one of the certificates executed and authenticated by the Trustee, substantially in the form specified in the relevant Trust Supplement.

Certificate Account: Means, with respect to the Certificates of any series, the account or accounts created and maintained for such series pursuant to Section 4.01(a) and the related Trust Supplement.

Certificateholder or Holder: Means, with respect to the Certificates of any series, the Person in whose name a Certificate of such series is registered in the Register for Certificates of such series.

Certificate Owner: Means, with respect to the Certificates of any series, for purposes of Section 3.05, the Person who owns a Book-Entry Certificate of such series.

Clearing Agency: Means an organization registered as a “clearing agency” pursuant to Section 17A of the Securities Exchange Act of 1934, as amended.

Clearing Agency Participant: Means a broker, dealer, bank, other financial institution or other Person for whom from time to time a Clearing Agency effects, directly or indirectly, book-entry transfers and pledges of securities deposited with the Clearing Agency.

Company: Means Sun Country, Inc., a Minnesota corporation, or its successor in interest pursuant to Section 5.02.

Controlling Party: Means, with respect to a series of Certificates, the Person entitled to act as such pursuant to the terms of the related Intercreditor Agreement.

Corporate Trust Office: Means, with respect to the Trustee or any Loan Trustee, the office of such trustee in the city at which at any particular time its corporate trust business shall be principally administered.

Cut-off Date: Means, with respect to the Certificates of any series, the date designated as such in the Trust Supplement establishing such series.

Definitive Certificates: Has the meaning, with respect to the Certificates of any series, specified in Section 3.05.

Direction: Has the meaning specified in Section 1.04(a).

Distribution Date: Means a Regular Distribution Date or a Special Distribution Date.

Equipment Notes: Means, with respect to the Certificates of any series, all of the equipment notes issued under the Indentures related to such series of Certificates.

ERISA: Means the Employee Retirement Income Security Act of 1974, as amended from time to time, or any successor federal statute.

Escrow Account: Has the meaning, with respect to the Certificates of any series, specified in Section 2.02(b).

Escrowed Funds: Has the meaning, with respect to any Trust, specified in Section 2.02(b).

Event of Default: Means, in respect of any Trust, an Indenture Event of Default under any Indenture pursuant to which Equipment Notes held by such Trust were issued.

Fractional Undivided Interest: Means the fractional undivided interest in a Trust that is evidenced by a Certificate relating to such Trust.

Indenture: Means, with respect to any Trust, each of the one or more separate trust indenture and security agreements or trust indenture and mortgages or similar documents described in, or on a schedule attached to, the Trust Supplement and an indenture having substantially the same terms and conditions which relates to a Substitute Aircraft, as each such indenture may be amended or supplemented in accordance with its respective terms; and "Indentures" means all of such agreements.

Indenture Event of Default: Means, with respect to any Indenture, any Indenture Event of Default (as such term is defined in such Indenture).

Initial Regular Distribution Date: Means, with respect to the Certificates of any series, the first Regular Distribution Date on which a Scheduled Payment is to be made.

Intercreditor Agreement: Means any agreement by and among the Trustee, as trustee hereunder with respect to one or more Trusts, one or more Liquidity Providers, if any, and a Subordination Agent providing, among other things, for the distribution of payments made in respect of Equipment Notes held by such Trusts.

Issuance Date: Means, with respect to the Certificates of any series, the date of the issuance of such Certificates.

Lease: Means any lease between an Owner Trustee, as the lessor, and the Company, as the lessee, referred to in the related Indenture, as such lease may be amended, supplemented or otherwise modified in accordance with its terms; and “Leases” means all such Leases.

Letter of Representations: Means, with respect to the Certificates of any series, an agreement between the Trustee and the initial Clearing Agency substantially in the form attached as an exhibit to the related Trust Supplement, as such letter may be amended, modified or supplemented.

Liquidity Facility: Means, with respect to the Certificates of any series, any revolving credit agreement, letter of credit or similar facility relating to the Certificates of such series between a bank or other financial institution and a Subordination Agent, as amended, replaced, supplemented or otherwise modified from time to time in accordance with its terms and the terms of any applicable Intercreditor Agreement.

Liquidity Provider: Means, with respect to the Certificates of any series, a bank or other financial institution that agrees to provide a Liquidity Facility for the benefit of the holders of Certificates of such series.

Loan Trustee: Means, with respect to any Equipment Note or the Indenture applicable thereto, the bank or trust company designated as loan or indenture trustee under such Indenture, and any successor to such Loan Trustee as such trustee; and “Loan Trustees” means all of the Loan Trustees under the Indentures.

Note Documents: Means, with respect to the Certificates of any series, the Equipment Notes with respect to such Certificates and, with respect to such Equipment Notes, the related Indenture, Note Purchase Agreement and, if the related Aircraft is leased to the Company, the related Lease and the related Owner Trustee’s Purchase Agreement.

Note Purchase Agreement: Means, with respect to the Certificates of any series, any note purchase, refunding, participation or similar agreement providing for, among other things, the purchase of Equipment Notes by the Trustee on behalf of the relevant Trust; and “Note Purchase Agreements” means all such agreements.

Officer’s Certificate: Means a certificate signed, (a) in the case of the Company, by the Chairman or Vice Chairman of the Board of Directors, the President, any Vice President or the Treasurer of the Company, signing alone, or (b) in the case of the Trustee or an Owner Trustee or a Loan Trustee, a Responsible Officer of the Trustee or such Owner Trustee or such Loan Trustee, as the case may be.

Opinion of Counsel: Means a written opinion of legal counsel who (a) in the case of counsel for the Company may be (i) a senior attorney of the Company one of whose principal duties is furnishing advice as to legal matters, (ii) Hughes Hubbard & Reed LLP or (iii) such other counsel designated by the Company and reasonably acceptable to the Trustee and (b) in the case of any Owner Trustee or any Loan Trustee, may be such counsel as may be designated by any of them whether or not such counsel is an employee of any of them, and who shall be reasonably acceptable to the Trustee.

Other Agreements: Has the meaning specified in Section 6.01(b).

Outstanding: When used with respect to Certificates of any series, means, as of the date of determination, all Certificates of such series theretofore authenticated and delivered under this Agreement, except:

(i) Certificates of such series theretofore cancelled by the Registrar or delivered to the Trustee or the Registrar for cancellation;

(ii) All of the Certificates of such series if money in the full amount required to make the final distribution with respect to such series pursuant to Section 11.01 hereof has been theretofore deposited with the Trustee in trust for the Holders of the Certificates of such series as provided in Section 4.01 pending distribution of such money to such Certificateholders pursuant to payment of such final distribution payment; and

(iii) Certificates of such series in exchange for or in lieu of which other Certificates of such series have been authenticated and delivered pursuant to this Agreement.

Owner Participant: Means, with respect to any Equipment Note, the “Owner Participant”, if any, as referred to in the Indenture pursuant to which such Equipment Note is issued and any permitted successor or assign of such Owner Participant; and “Owner Participants” at any time of determination means all of the Owner Participants thus referred to in the Indentures.

Owner Trustee: Means, with respect to any Equipment Note, the “Owner Trustee”, if any, as referred to in the Indenture pursuant to which such Equipment Note is issued, not in its individual capacity but solely as trustee; and “Owner Trustees” means all of the Owner Trustees party to any of the related Indentures.

Owner Trustee’s Purchase Agreement: Has the meaning, with respect to the Certificates of any series if the related Aircraft is leased to the Company, specified therefor in the related Lease.

Paying Agent: Means, with respect to the Certificates of any series, the paying agent maintained and appointed for the Certificates of such series pursuant to Section 7.12.

Permitted Investments: Means obligations of the United States of America or agencies or instrumentalities thereof for the payment of which the full faith and credit of the United States of America is pledged, maturing in not more than 60 days after the date of acquisition thereof or such lesser time as is required for the distribution of any Special Payments on a Special Distribution Date.

Person: Means any person, including any individual, corporation, limited liability company, partnership, joint venture, association, joint-stock company, trust, trustee, unincorporated organization, or government or any agency or political subdivision thereof.

Pool Balance: Means, with respect to the Certificates of any series as of any date, (i) the original aggregate face amount of the Certificates of any series less (ii) the aggregate amount of all payments made in respect of such Certificates other than payments made in respect of interest or premium thereon or reimbursement of any costs or expenses incurred in connection therewith. The Pool Balance as of any Distribution Date shall be computed after giving effect to the payment of principal, if any, on the Equipment Notes or other Trust Property held in the Trust and the distribution thereof to be made on such Distribution Date.

Pool Factor: Means, with respect to any series of Certificates as of any date, the quotient (rounded to the seventh decimal place) computed by dividing (i) the Pool Balance of such series as at such date by (ii) the original aggregate face amount of the Certificates of such series. The Pool Factor as of any Distribution Date shall be computed after giving effect to the payment of principal, if any, on the Equipment Notes or other Trust Property held in the Trust and the distribution thereof to be made on such Distribution Date.

Postponed Notes: Means, with respect to any Trust or the related series of Certificates, the Equipment Notes to be held in such Trust as to which a Postponement Notice shall have been delivered pursuant to Section 2.02(b).

Postponement Notice: Means, with respect to any Trust or the related series of Certificates, an Officer's Certificate of the Company signed by an officer of the Company (1) requesting that the Trustee temporarily postpone purchase of the related Equipment Notes to a date later than the Issuance Date of such series of Certificates, (2) identifying the amount of the purchase price of each such Equipment Note and the aggregate purchase price for all such Equipment Notes, (3) setting forth the reasons for such postponement and (4) with respect to each such Equipment Note, either (a) setting or resetting a new Transfer Date (which shall be on or prior to the applicable Cut-off Date) for payment by the Trustee of such purchase price and issuance of the related Equipment Note (subject to subsequent change from time to time in accordance with the relevant Note Purchase Agreement), or (b) indicating that such new Transfer Date (which shall be on or prior to the applicable Cut-off Date) will be set by subsequent written notice not less than one Business Day prior to such new Transfer Date (subject to subsequent change from time to time in accordance with the relevant Note Purchase Agreement).

Potential Purchaser: Has the meaning, with respect to any Certificateholder, specified in Section 6.01(b).

PTC Event of Default: With respect to Certificates of any series, (i) has the meaning set forth in any related Intercreditor Agreement, or (ii) if not defined, in any such Intercreditor Agreement, means any failure to pay within ten Business Days of the



due date thereof: (a) the outstanding Pool Balance of such series of Certificates on the date specified in any Trust Supplement for such payment or (b) interest due on the Certificates of such series on any Distribution Date.

Purchasing Certificateholder: Has the meaning, with respect to any Certificateholder, specified in Section 6.01(b).

Record Date: Means, with respect to any Trust or the related series of Certificates, (i) for Scheduled Payments to be distributed on any Regular Distribution Date, other than the final distribution with respect to such series, the 15th day (whether or not a Business Day) preceding such Regular Distribution Date, and (ii) for Special Payments to be distributed on any Special Distribution Date, other than the final distribution with respect to such series, the 15th day (whether or not a Business Day) preceding such Special Distribution Date.

Register and Registrar: Means, each with respect to the Certificates of any series, the register maintained and the registrar appointed pursuant to Sections 3.04 and 7.12.

Regular Distribution Date: Means, with respect to distributions of Scheduled Payments in respect of any series of Certificates, each date designated as such in this Agreement, until payment of all the Scheduled Payments to be made under the Equipment Notes held in the Trust has been made.

Request: Means a request by the Company setting forth the subject matter of the request accompanied by an Officer's Certificate and an Opinion of Counsel as provided in Section 1.02 of this Basic Agreement.

Responsible Officer: Means, with respect to any Trustee, any Loan Trustee and any Owner Trustee, any officer in the Corporate Trust Department of the Trustee, Loan Trustee or Owner Trustee or any other officer customarily performing functions similar to those performed by the persons who at the time shall be such officers, respectively, or to whom any corporate trust matter is referred because of his knowledge of and familiarity with a particular subject.

Responsible Party: Means, with respect to the Certificates of any series, the person designated as such in the related Trust Supplement.

Scheduled Payment: Means, with respect to any Equipment Note, (i) any payment of principal or interest on such Equipment Note (other than any such payment which is not in fact received by the Trustee or the applicable Subordination Agent within five days of the date on which such payment is scheduled to be made) or (ii) any payment of interest on the Certificates of any series with funds drawn under the Liquidity Facility for such series, which payment represents the installment of principal on such Equipment Note at the stated maturity of such installment, the payment of regularly scheduled interest accrued on the unpaid principal amount of such Equipment Note, or both; provided, however, that any payment of principal, premium, if any, or interest resulting from the redemption or purchase of any Equipment Note shall not constitute a Scheduled Payment.

SEC: Means the Securities and Exchange Commission, as from time to time constituted or created under the Securities Exchange Act of 1934, as amended, or, if at any time after the execution of this instrument such Commission is not existing and performing the duties now assigned to it under the Trust Indenture Act, then the body performing such duties on such date.

Selling Certificateholder: Has the meaning, with respect to any Certificateholder, specified in Section 6.01(b).

Special Distribution Date: Means, with respect to the Certificates of any series, each date on which a Special Payment is to be distributed as specified in this Agreement.

Special Payment: Means (i) any payment (other than a Scheduled Payment) in respect of, or any proceeds of, any Equipment Note or Trust Indenture Estate (as defined in each Indenture), (ii) the amounts required to be distributed pursuant to the last paragraph of Section 2.02(b) or (iii) the amounts required to be distributed pursuant to the penultimate paragraph of Section 2.02(b).

Special Payments Account: Means, with respect to the Certificates of any series, the account or accounts created and maintained for such series pursuant to Section 4.01(b) and the related Trust Supplement.

Specified Investments: Means, with respect to any Trust, unless otherwise specified in the related Trust Supplement, (i) obligations of, or guaranteed by, the United States Government or agencies thereof, (ii) open market commercial paper of any corporation incorporated under the laws of the United States of America or any state thereof rated at least P-2 or its equivalent by Moody's Investors Service, Inc. or at least A-2 or its equivalent by Standard & Poor's Ratings Services, a Standard & Poor's Financial Services LLC business, (iii) certificates of deposit issued by commercial banks organized under the laws of the United States or of any political subdivision thereof having a combined capital and surplus in excess of \$100,000,000 which banks or their holding companies have a rating of A or its equivalent by Moody's Investors Service, Inc. or Standard & Poor's Ratings Services, a Standard & Poor's Financial Services LLC business; provided, however, that the aggregate amount at any one time so invested in certificates of deposit issued by any one bank shall not exceed 5% of such bank's capital and surplus, (iv) U.S. dollar-denominated offshore certificates of deposit issued by, or offshore time deposits with, any commercial bank described in clause (iii) above or any subsidiary thereof and (v) repurchase agreements with any financial institution having combined capital and surplus of at least \$100,000,000 with any of the obligations described in clauses (i) through (iv) above as collateral; provided further that if all of the above investments are unavailable, the entire amounts to be invested may be used to purchase federal funds from an entity described in clause (iii) above.

Subordination Agent: Has the meaning specified therefor in the applicable Intercreditor Agreement.

Substitute Aircraft: Means, with respect to any Trust, any Aircraft of a type specified in this Agreement and, at the election of the Company, substituted prior to the applicable Cut-off Date, if any, pursuant to the terms of this Agreement.

Transfer Date: Has the meaning assigned to that term or any of the terms “Delivery Date”, “Funding Date” or “Closing Date” in the applicable Note Purchase Agreement, and in any event refers to any such date as it may be changed from time to time in accordance with the terms of such Note Purchase Agreement.

Triggering Event: Has the meaning specified therefor in the applicable Intercreditor Agreement.

Trust: Means, with respect to the Certificates of any series, the related trust under this Agreement.

Trustee: Means Wilmington Trust, National Association, or its successor in interest, and any successor or other trustee appointed as provided herein.

Trust Indenture Act: Means, with respect to any particular Trust, the United States Trust Indenture Act of 1939, as in force at the date as of which the related Trust Supplement was executed.

Trust Property: Means, with respect to any Trust, (i) subject to any related Intercreditor Agreement, the Equipment Notes held as the property of such Trust, all monies at any time paid thereon and all monies due and to become due thereunder, (ii) funds from time to time deposited in the related Escrow Account, the related Certificate Account and the related Special Payments Account and, subject to the related Intercreditor Agreement, any proceeds from the sale by the Trustee pursuant to Article VI hereof of any such Equipment Note, (iii) all rights of such Trust and the Trustee, on behalf of the Trust, under any Intercreditor Agreement, including, without limitation, all monies receivable in respect of such rights, and (iv) all monies receivable under any Liquidity Facility for such Trust.

Trust Supplement: Means an agreement supplemental hereto pursuant to which (i) a separate Trust is created for the benefit of the Holders of the Certificates of a series, (ii) the issuance of the Certificates of such series representing fractional undivided interests in such Trust is authorized and (iii) the terms of the Certificates of such series are established.

Section 1.02. Compliance Certificates and Opinions. Upon any application or request by the Company, any Owner Trustee or any Loan Trustee to the Trustee to take any action under any provision of this Basic Agreement or, in respect of the Certificates of any series, this Agreement, the Company, such Owner Trustee or such Loan Trustee, as the case may be, shall furnish to the Trustee (i) an Officer’s Certificate stating that, in the opinion of the signer or signers, all conditions precedent, if any, provided for in this Basic Agreement or this Agreement relating to the proposed action have been complied with and (ii) an Opinion of Counsel stating that in the opinion of such counsel all such conditions precedent, if any, have been complied with, except that in the case of any such application or request as to which the

furnishing of such documents is specifically required by any provision of this Basic Agreement or this Agreement relating to such particular application or request, no such Officer's Certificate or Opinion of Counsel need be furnished.

Every certificate or opinion with respect to compliance with a condition or covenant provided for in this Basic Agreement or, in respect of the Certificates of any series, this Agreement (other than a certificate provided pursuant to Section 8.04(d)) or any Trust Supplement shall include:

- (1) a statement that each individual signing such certificate or each firm or individual signing such opinion has read such covenant or condition and the definitions in this Basic Agreement or this Agreement relating thereto;
- (2) a brief statement as to the nature and scope of the examination or investigation upon which the statements or opinions contained in such certificate or opinion are based;
- (3) a statement that, in the opinion of each such individual or firm, he or it has made such examination or investigation as is necessary to enable him or it to express an informed opinion as to whether or not such covenant or condition has been complied with; and
- (4) a statement as to whether, in the opinion of each such individual or firm, such condition or covenant has been complied with.

Section 1.03. Form of Documents Delivered to Trustee. In any case where several matters are required to be certified by, or covered by an opinion of, any specified Person, it is not necessary that all such matters be certified by, or covered by the opinion of, only one such Person, or that they be so certified or covered by only one document, but one such Person may certify or give an opinion with respect to some matters and one or more other such Persons as to other matters and any such Person may certify or give an opinion as to such matters in one or several documents.

Where any Person is required to make, give or execute two or more applications, requests, consents, certificates, statements, opinions or other instruments under this Basic Agreement or, in respect of the Certificates of any series, this Agreement, they may, but need not, be consolidated and form one instrument.

Section 1.04. Directions of Certificateholders. (a) Any direction, consent, request, demand, authorization, notice, waiver or other action provided by this Agreement in respect of the Certificates of any series to be given or taken by Certificateholders (a "Direction") may be embodied in and evidenced by one or more instruments of substantially similar tenor signed by such Certificateholders in person or by an agent or proxy duly appointed in writing; and, except as herein otherwise expressly provided, such action shall become effective when such instrument or instruments are delivered to the Trustee and, when it is hereby expressly required pursuant to this Agreement, to the Company or any Loan Trustee. Such instrument or instruments (and the action embodied therein and evidenced thereby) are herein sometimes referred to as the "Act" of the Certificateholders signing such instrument or instruments. Proof

of execution of any such instrument or of a writing appointing any such agent or proxy shall be sufficient for any purpose of this Trust Agreement and conclusive in favor of the Trustee, the Company and the related Loan Trustee, if made in the manner provided in this Section 1.04.

(b) The fact and date of the execution by any Person of any such instrument or writing may be proved by the certificate of any notary public or other officer of any jurisdiction authorized to take acknowledgments of deeds or administer oaths that the Person executing such instrument acknowledged to him the execution thereof, or by an affidavit of a witness to such execution sworn to before any such notary or such other officer, and where such execution is by an officer of a corporation or association or a member of a partnership, on behalf of such corporation, association or partnership, such certificate or affidavit shall also constitute sufficient proof of his authority. The fact and date of the execution of any such instrument or writing, or the authority of the Person executing the same, may also be proved in any other reasonable manner which the Trustee deems sufficient.

(c) In determining whether the Certificateholders of the requisite Fractional Undivided Interests of Certificates of any series Outstanding have given any Direction under this Agreement, Certificates owned by the Company or any Affiliate thereof shall be disregarded and deemed not to be Outstanding for purposes of any such determination. In determining whether the Trustee shall be protected in relying upon any such Direction, only Certificates which the Trustee knows to be so owned shall be so disregarded. Notwithstanding the foregoing, (i) if any such Person owns 100% of the Certificates of any series Outstanding, such Certificates shall not be so disregarded, and (ii) if any amount of Certificates of any series so owned by any such Person have been pledged in good faith, such Certificates shall not be disregarded if the pledgee establishes to the satisfaction of the Trustee the pledgee's right so to act with respect to such Certificates and that the pledgee is not the Company or any Affiliate thereof.

(d) The Company may, at its option, by delivery of an Officer's Certificate to the Trustee, set a record date to determine the Certificateholders in respect of the Certificates of any series, entitled to give any Direction. Such record date shall be the record date specified in such Officer's Certificate, which shall be a date not more than 30 days prior to the first solicitation of Certificateholders of the applicable series in connection therewith. If such a record date is fixed, such Direction may be given before or after such record date, but only the Certificateholders of record of the applicable series at the close of business on such record date shall be deemed to be Certificateholders for the purposes of determining whether Certificateholders of the requisite proportion of Outstanding Certificates of such series have authorized or agreed or consented to such Direction, and for that purpose the Outstanding Certificates shall be computed as of such record date; provided, however, that no such Direction by the Certificateholders on such record date shall be deemed effective unless it shall become effective pursuant to the provisions of this Agreement not later than one year after such record date.

(e) Any Direction by the Holder of any Certificate shall bind the Holder of every Certificate issued upon the transfer thereof or in exchange therefor or in lieu thereof, whether or not notation of such Direction is made upon such Certificate.

(f) Except as otherwise provided in Section 1.04(c), Certificates of any series owned by or pledged to any Person shall have an equal and proportionate benefit under the provisions of this Agreement, without preference, priority or distinction as among all of the Certificates of such series.

## ARTICLE II

### ORIGINAL ISSUANCE OF CERTIFICATES; ACQUISITION OF TRUST PROPERTY

Section 2.01. Amount Unlimited; Issuable in Series. (a) The aggregate face amount of Certificates which may be authenticated and delivered under this Basic Agreement is unlimited. The Certificates may be issued from time to time in one or more series and shall be designated generally as the “Pass Through Certificates”, with such further designations added or incorporated in such title for the Certificates of each series as specified in the related Trust Supplement. Each Certificate shall bear upon its face the designation so selected for the series to which it belongs. All Certificates of the same series shall be substantially identical except that the Certificates of a series may differ as to denomination and as may otherwise be provided in the Trust Supplement establishing the Certificates of such series. Each series of Certificates issued pursuant to this Agreement will evidence fractional undivided interests in the related Trust and, except as may be contained in any Intercreditor Agreement, will have no rights, benefits or interests in respect of any other Trust or the Trust Property held therein. All Certificates of the same series shall be in all respects equally and ratably entitled to the benefits of this Agreement without preference, priority or distinction on account of the actual time or times of authentication and delivery, all in accordance with the terms and provisions of this Agreement.

(b) The following matters shall be established with respect to the Certificates of each series issued hereunder by a Trust Supplement executed and delivered by and between the Company and the Trustee:

(1) the formation of the Trust as to which the Certificates of such series represent fractional undivided interests and its designation (which designation shall distinguish such Trust from each other Trust created under this Basic Agreement and a Trust Supplement);

(2) the specific title of the Certificates of such series (which title shall distinguish the Certificates of such series from each other series of Certificates created under this Basic Agreement and a Trust Supplement);

(3) any limit upon the aggregate face amount of the Certificates of such series which may be authenticated and delivered (which limit shall not pertain to Certificates authenticated and delivered upon registration of transfer of, or in exchange for, or in lieu of, other Certificates of the series pursuant to Sections 3.03, 3.04 and 3.06);

(4) the Cut-off Date with respect to the Certificates of such series;

(5) the Regular Distribution Dates applicable to the Certificates of such series;

- (6) the Special Distribution Dates applicable to the Certificates of such series;
- (7) if other than as provided in Section 7.12(b), the Registrar or the Paying Agent for the Certificates of such series, including any Co-Registrar or additional Paying Agent;
- (8) if other than as provided in Section 3.01, the denominations in which the Certificates of such series shall be issuable;
- (9) if other than United States dollars, the currency or currencies (including currency units) in which the Certificates of such series shall be denominated;
- (10) the specific form of the Certificates of such series (including the interest rate applicable thereto) and whether or not Certificates of such series are to be issued as Book-Entry Certificates and, if such Certificates are to be Book-Entry Certificates, the form of Letter of Representations, if any (or, in the case of any Certificates denominated in a currency other than United States dollars and if other than as provided in Section 3.05, whether and the circumstances under which beneficial owners of interests in such Certificates in permanent global form may exchange such interests for Certificates of such series and of like tenor of any authorized form and denomination);
- (11) a description of the Equipment Notes to be acquired and held in the related Trust and of the related Aircraft and Note Documents;
- (12) provisions with respect to the terms for which the definitions set forth in Article I hereof or the terms of Section 11.01 hereof require further specification in the related Trust Supplement;
- (13) any restrictions (including legends) in respect of ERISA;
- (14) whether such series will be subject to an Intercreditor Agreement and, if so, the specific designation of such Intercreditor Agreement;
- (15) whether such series will have the benefit of a Liquidity Facility and, if so, the specific designation of such Liquidity Facility;
- (16) whether any guarantor will guarantee the obligations of the Company under any Equipment Notes to be acquired and held in the Trust formed by such Trust Supplement;
- (17) whether there will be a deposit agreement or other comparable arrangement prior to the delivery of one or more Aircraft and, if so, any terms appropriate thereto; and
- (18) any other terms of the Certificates of such series, including any terms of the Certificates of such series which may be required or advisable under United States laws or regulations or advisable in connection with the marketing of Certificates of the series.

(c) At any time and from time to time after the execution and delivery of this Basic Agreement and a Trust Supplement forming a Trust and establishing the terms of Certificates of a series, Certificates of such series shall be executed, authenticated and delivered by the Trustee to the Person or Persons specified by the Company upon request of the Company and upon satisfaction or waiver of any conditions precedent set forth in such Trust Supplement.

Section 2.02. Acquisition of Equipment Notes. (a) Unless otherwise specified in the related Trust Supplement, on or prior to the Issuance Date of the Certificates of a series, the Trustee shall execute and deliver the related Note Purchase Agreements in the form delivered to the Trustee by the Company and shall, subject to the respective terms thereof, perform its obligations under such Note Purchase Agreements. The Trustee shall issue and sell such Certificates, in authorized denominations and in such Fractional Undivided Interests, so as to result in the receipt of consideration in an amount equal to the aggregate purchase price of the Equipment Notes contemplated to be purchased by the Trustee under the related Note Purchase Agreements and, concurrently therewith, the Trustee shall purchase, pursuant to the terms and conditions of the Note Purchase Agreements, such Equipment Notes at a purchase price equal to the amount of such consideration so received. Except as provided in Sections 3.03, 3.04 and 3.06 hereof, the Trustee shall not execute, authenticate or deliver Certificates of such series in excess of the aggregate amount specified in this paragraph. The provisions of this Subsection (a) are subject to the provisions of Subsection (b) below.

(b) If on or prior to the Issuance Date with respect to a series of Certificates the Company shall deliver to the Trustee a Postponement Notice relating to one or more Postponed Notes, the Trustee shall postpone the purchase of such Postponed Notes and shall deposit into an escrow account (as to such Trust, the "Escrow Account") to be maintained as part of the related Trust an amount equal to the purchase price of such Postponed Notes (the "Escrowed Funds"). The portion of the Escrowed Funds so deposited with respect to any particular Postponed Notes shall be invested by the Trustee at the written direction and risk of, and for the benefit of, the Responsible Party in Specified Investments (i) maturing no later than any scheduled Transfer Date relating to such Postponed Notes or (ii) if no such Transfer Date has been scheduled, maturing on the next Business Day, or (iii) if the Company has given notice to the Trustee that such Postponed Notes will not be issued, maturing on the next applicable Special Distribution Date, if such investments are reasonably available for purchase. The Trustee shall make withdrawals from the Escrow Account only as provided in this Agreement. Upon request of the Company on one or more occasions and the satisfaction or waiver of the closing conditions specified in the applicable Note Purchase Agreements on or prior to the related Cut- off Date, the Trustee shall purchase the applicable Postponed Notes with the Escrowed Funds withdrawn from the Escrow Account. The purchase price shall equal the principal amount of such Postponed Notes.

The Trustee shall hold all Specified Investments until the maturity thereof and will not sell or otherwise transfer Specified Investments. If Specified Investments held in an Escrow Account mature prior to any applicable Transfer Date, any proceeds received on the maturity of such Specified Investments (other than any earnings thereon) shall be reinvested by the Trustee at the written direction and risk of, and for the benefit of, the Responsible Party in Specified Investments maturing as provided in the preceding paragraph.



Any earnings on Specified Investments received from time to time by the Trustee shall be promptly distributed to the Responsible Party. The Responsible Party shall pay to the Trustee for deposit to the relevant Escrow Account an amount equal to any losses on such Specified Investments as incurred. On the Initial Regular Distribution Date in respect of the Certificates of any series, the Responsible Party will pay (in immediately available funds) to the Trustee an amount equal to the interest that would have accrued on any Postponed Notes with respect to such Certificates, if any, purchased after the Issuance Date if such Postponed Notes had been purchased on the Issuance Date, from the Issuance Date to, but not including, the date of the purchase of such Postponed Notes by the Trustee.

If, in respect of the Certificates of any series, the Company notifies the Trustee prior to the Cut-off Date that any Postponed Notes will not be issued on or prior to the Cut-off Date for any reason, on the next Special Distribution Date for such Certificates occurring not less than 15 days following the date of such notice, (i) the Responsible Party shall pay to the Trustee for deposit in the related Special Payments Account, in immediately available funds, an amount equal to the interest that would have accrued on the Postponed Notes designated in such notice at a rate equal to the interest rate applicable to such Certificates from the Issuance Date to, but not including, such Special Distribution Date and (ii) the Trustee shall transfer an amount equal to that amount of Escrowed Funds that would have been used to purchase the Postponed Notes designated in such notice and the amount paid by the Responsible Party pursuant to the immediately preceding clause (i) to the related Special Payments Account for distribution as a Special Payment in accordance with the provisions hereof.

If, on such Cut-off Date, an amount equal to less than all of the Escrowed Funds (other than Escrowed Funds referred to in the immediately preceding paragraph) has been used to purchase Postponed Notes, on the next such Special Distribution Date occurring not less than 15 days following such Cut-off Date (i) the Responsible Party shall pay to the Trustee for deposit in such Special Payments Account, in immediately available funds, an amount equal to the interest that would have accrued on such Postponed Notes contemplated to be purchased with such unused Escrowed Funds (other than Escrowed Funds referred to in the immediately preceding paragraph) but not so purchased at a rate equal to the interest rate applicable to such Certificates from the Issuance Date to, but not including, such Special Distribution Date and (ii) the Trustee shall transfer such unused Escrowed Funds and the amount paid by the Responsible Party pursuant to the immediately preceding clause (i) to such Special Payments Account for distribution as a Special Payment in accordance with the provisions hereof.

Section 2.03. Acceptance by Trustee. Upon the execution and delivery of a Trust Supplement creating a Trust and establishing a series of Certificates, the Trustee shall acknowledge its acceptance of all right, title and interest in and to the Trust Property to be acquired pursuant to Section 2.02 hereof and the related Note Purchase Agreements and shall declare that the Trustee holds and will hold such right, title and interest for the benefit of all then present and future Certificateholders of such series, upon the trusts herein and in such Trust Supplement set forth. By the acceptance of each Certificate of such series issued to it under this Agreement, each initial Holder of such series as grantor of such Trust shall thereby join in the creation and declaration of such Trust.

Section 2.04. Limitation of Powers. Each Trust shall be constituted solely for the purpose of making the investment in the Equipment Notes provided for in the related Trust Supplement, and, except as set forth herein, the Trustee shall not be authorized or empowered to acquire any other investments or engage in any other activities and, in particular, the Trustee shall not be authorized or empowered to do anything that would cause such Trust to fail to qualify as a “grantor trust” for federal income tax purposes (including, as subject to this restriction, acquiring any Aircraft (as defined in the respective Indentures) by bidding such Equipment Notes or otherwise, or taking any action with respect to any such Aircraft once acquired).

### ARTICLE III

#### THE CERTIFICATES

Section 3.01. Form, Denomination and Execution of Certificates. The Certificates of each series shall be issued in fully registered form without coupons and shall be substantially in the form as specified in the applicable Trust Supplement, with such omissions, variations and insertions as are permitted by this Agreement, and may have such letters, numbers or other marks of identification and such legends or endorsements placed thereon as may be required to comply with the rules of any securities exchange on which such Certificates may be listed or to conform to any usage in respect thereof, or as may, consistently herewith, be determined by the Trustee or the officers executing such Certificates, as evidenced by the Trustee’s or respective officers’ execution of the Certificates.

Except as provided in Section 3.05, the definitive Certificates of such series shall be typed, printed, lithographed or engraved or produced by any combination of these methods or may be produced in any other manner permitted by the rules of any securities exchange on which the Certificates may be listed, all as determined by the officers executing such Certificates, as evidenced by their execution of such Certificates.

Except as otherwise provided in the related Trust Supplement, the Certificates of each series shall be issued in minimum denominations of \$1,000 or integral multiples thereof except that one Certificate of such series may be issued in a different denomination.

The Certificates of such series shall be executed on behalf of the Trustee by manual or facsimile signature of a Responsible Officer of the Trustee. Certificates of any series bearing the manual or facsimile signature of an individual who was, at the time when such signature was affixed, authorized to sign on behalf of the Trustee shall be valid and binding obligations of the Trustee, notwithstanding that such individual has ceased to be so authorized prior to the authentication and delivery of such Certificates or did not hold such office at the date of such Certificates.

Section 3.02. Authentication of Certificates. (a) On the Issuance Date, the Trustee shall duly execute, authenticate and deliver Certificates of each series in authorized denominations equaling in the aggregate the aggregate principal amount of the Equipment Notes that may be purchased by the Trustee pursuant to the related Note Purchase Agreements, and evidencing the entire ownership of the related Trust. Thereafter, the Trustee shall duly execute, authenticate and deliver the Certificates of such series as herein provided.

(b) No Certificate of any series shall be entitled to any benefit under this Agreement, or be valid for any purpose, unless there appears on such Certificate a certificate of authentication substantially in the form set forth in the applicable Trust Supplement executed by the Trustee by manual signature, and such certificate of authentication upon any Certificate shall be conclusive evidence, and the only evidence, that such Certificate has been duly authenticated and delivered hereunder. All Certificates of any series shall be dated the date of their authentication.

Section 3.03. Temporary Certificates. Until definitive Certificates are ready for delivery, the Trustee shall execute, authenticate and deliver temporary Certificates of each series. Temporary Certificates of each series shall be substantially in the form of definitive Certificates of such series but may have insertions, substitutions, omissions and other variations determined to be appropriate by the officers executing the temporary Certificates of such series, as evidenced by their execution of such temporary Certificates. If temporary Certificates of any series are issued, the Trustee will cause definitive Certificates of such series to be prepared without unreasonable delay. After the preparation of definitive Certificates of such series, the temporary Certificates shall be exchangeable for definitive Certificates upon surrender of such temporary Certificates at the office or agency of the Trustee designated for such purpose pursuant to Section 7.12, without charge to the Certificateholder. Upon surrender for cancellation of any one or more temporary Certificates, the Trustee shall execute, authenticate and deliver in exchange therefor a like face amount of definitive Certificates of like series, in authorized denominations and of a like Fractional Undivided Interest. Until so exchanged, such temporary Certificates shall be entitled to the same benefits under this Agreement as definitive Certificates.

Section 3.04. Transfer and Exchange. The Trustee shall cause to be kept at the office or agency to be maintained by it in accordance with the provisions of Section 7.12 a register (the "Register") for each series of Certificates in which, subject to such reasonable regulations as it may prescribe, the Trustee shall provide for the registration of Certificates of such series and of transfers and exchanges of such Certificates as herein provided. The Trustee shall initially be the registrar (the "Registrar") for the purpose of registering such Certificates of each series and transfers and exchanges of such Certificates as herein provided.

All Certificates issued upon any registration of transfer or exchange of Certificates of any series shall be valid obligations of the applicable Trust, evidencing the same interest therein, and entitled to the same benefits under this Agreement, as the Certificates of such series surrendered upon such registration of transfer or exchange.

Upon surrender for registration of transfer of any Certificate at the Corporate Trust Office or such other office or agency, the Trustee shall execute, authenticate and deliver, in the name of the designated transferee or transferees, one or more new Certificates of like series, in authorized denominations of a like aggregate Fractional Undivided Interest.

At the option of a Certificateholder, Certificates may be exchanged for other Certificates of like series, in authorized denominations and of a like aggregate Fractional

Undivided Interest, upon surrender of the Certificates to be exchanged at any such office or agency. Whenever any Certificates are so surrendered for exchange, the Trustee shall execute, authenticate and deliver the Certificates that the Certificateholder making the exchange is entitled to receive. Every Certificate presented or surrendered for registration of transfer or exchange shall be duly endorsed or accompanied by a written instrument of transfer in form satisfactory to the Trustee and the Registrar duly executed by the Certificateholder thereof or its attorney duly authorized in writing.

No service charge shall be made to a Certificateholder for any registration of transfer or exchange of Certificates, but the Trustee shall require payment of a sum sufficient to cover any tax or governmental charge that may be imposed in connection with any transfer or exchange of Certificates. All Certificates surrendered for registration of transfer or exchange shall be cancelled and subsequently destroyed by the Trustee.

Section 3.05. Book-Entry and Definitive Certificates. (a) The Certificates of any series may be issued in the form of one or more typewritten Certificates representing the Book-Entry Certificates of such series, to be delivered to DTC, the initial Clearing Agency, by, or on behalf of, the Company. In such case, the Certificates of such series delivered to DTC shall initially be registered on the Register in the name of Cede & Co., the nominee of the initial Clearing Agency, and no Certificate Owner will receive a definitive certificate representing such Certificate Owner's interest in the Certificates of such series, except as provided above and in Subsection (d) below. As to the Certificates of any series, unless and until definitive, fully registered Certificates (the "Definitive Certificates") have been issued pursuant to Subsection (d) below:

(i) the provisions of this Section 3.05 shall be in full force and effect;

(ii) the Company, the Paying Agent, the Registrar and the Trustee may deal with the Clearing Agency Participants for all purposes (including the making of distributions on the Certificates) as the authorized representatives of the Certificate Owners;

(iii) to the extent that the provisions of this Section 3.05 conflict with any other provisions of this Agreement (other than the provisions of any Trust Supplement expressly amending this Section 3.05 as permitted by this Basic Agreement), the provisions of this Section 3.05 shall control;

(iv) the rights of Certificate Owners shall be exercised only through the Clearing Agency and shall be limited to those established by law and agreements between such Certificate Owners and the Clearing Agency Participants; and until Definitive Certificates are issued pursuant to Subsection (d) below, the Clearing Agency will make book-entry transfers among the Clearing Agency Participants and receive and transmit distributions of principal, interest and premium, if any, on the Certificates to such Clearing Agency Participants; and

(v) whenever this Agreement requires or permits actions to be taken based upon instructions or directions of Certificateholders of such series holding Certificates of

such series evidencing a specified percentage of the Fractional Undivided Interests in the related Trust, the Clearing Agency shall be deemed to represent such percentage only to the extent that it has received instructions to such effect from Clearing Agency Participants owning or representing, respectively, such required percentage of the beneficial interest in Certificates of such series and has delivered such instructions to the Trustee. The Trustee shall have no obligation to determine whether the Clearing Agency has in fact received any such instructions.

(b) Whenever notice or other communication to the Certificateholders of such series is required under this Agreement, unless and until Definitive Certificates shall have been issued pursuant to Subsection (d) below, the Trustee shall give all such notices and communications specified herein to be given to Certificateholders of such series to the Clearing Agency.

(c) Unless and until Definitive Certificates of a series are issued pursuant to Subsection (d) below, on the Record Date prior to each applicable Regular Distribution Date and Special Distribution Date, as stated in Section 4.03(a) the Trustee will request from the Clearing Agency a securities position listing setting forth the names of all Clearing Agency Participants reflected on the Clearing Agency's books as holding interests in the Certificates on such Record Date.

(d) If with respect to the Certificates of any series (i) the Company advises the Trustee in writing that the Clearing Agency is no longer willing or able to discharge properly its responsibilities and the Trustee or the Company is unable to locate a qualified successor, (ii) the Company, at its option, advises the Trustee in writing that it elects to terminate the book-entry system through the Clearing Agency or (iii) after the occurrence of an Event of Default, Certificate Owners of Book-Entry Certificates of such series evidencing Fractional Undivided Interests aggregating not less than a majority in interest in the related Trust, by Act of such Certificate Owners delivered to the Company and the Trustee, advise the Company, the Trustee and the Clearing Agency through the Clearing Agency Participants in writing that the continuation of a book-entry system through the Clearing Agency Participants is no longer in the best interests of the Certificate Owners of such series, then the Trustee shall notify all Certificate Owners of such series, through the Clearing Agency, of the occurrence of any such event and of the availability of Definitive Certificates. Upon surrender to the Trustee of all the Certificates of such series held by the Clearing Agency, accompanied by registration instructions from the Clearing Agency Participants for registration of Definitive Certificates in the names of Certificate Owners of such series, the Trustee shall issue and deliver the Definitive Certificates of such series in accordance with the instructions of the Clearing Agency. Neither the Company, the Registrar, the Paying Agent nor the Trustee shall be liable for any delay in delivery of such instructions and may conclusively rely on, and shall be protected in relying on, such registration instructions. Upon the issuance of Definitive Certificates of such series, the Trustee shall recognize the Person in whose name the Definitive Certificates are registered in the Register as Certificateholders hereunder. Neither the Company nor the Trustee shall be liable to the Certificateholders or any other Person if the Trustee or the Company is unable to locate a qualified successor Clearing Agency.

(e) Except as otherwise provided in the related Trust Supplement, the Trustee shall enter into the applicable Letter of Representations with respect to such series of Certificates and fulfill its responsibilities thereunder.

(f) The provisions of this Section 3.05 may be made inapplicable to any series or may be amended with respect to any series in the related Trust Supplement.

Section 3.06. Mutilated, Destroyed, Lost or Stolen Certificates. If (a) any mutilated Certificate is surrendered to the Registrar, or the Registrar receives evidence to its satisfaction of the destruction, loss or theft of any Certificate, and (b) there is delivered to the Registrar and the Trustee such security, indemnity or bond, as may be required by them to save each of them harmless, then, in the absence of notice to the Registrar or the Trustee that such destroyed, lost or stolen Certificate has been acquired by a *bona fide* purchaser, and provided, however, that the requirements of Section 8-405 of the Uniform Commercial Code in effect in any applicable jurisdiction are met, the Trustee shall execute, authenticate and deliver, in exchange for or in lieu of any such mutilated, destroyed, lost or stolen Certificate, a new Certificate or Certificates of like series, in authorized denominations and of like Fractional Undivided Interest and bearing a number not contemporaneously outstanding.

In connection with the issuance of any new Certificate under this Section 3.06, the Trustee shall require the payment of a sum sufficient to cover any tax or other governmental charge that may be imposed in relation thereto and any other expenses (including the fees and expenses of the Trustee and the Registrar) connected therewith.

Any duplicate Certificate issued pursuant to this Section 3.06 shall constitute conclusive evidence of the appropriate Fractional Undivided Interest in the related Trust, as if originally issued, whether or not the lost, stolen or destroyed Certificate shall be found at any time.

The provisions of this Section 3.06 are exclusive and shall preclude (to the extent lawful) all other rights and remedies with respect to the replacement or payment of mutilated, destroyed, lost or stolen Certificates.

Section 3.07. Persons Deemed Owners. Prior to due presentment of a Certificate for registration of transfer, the Trustee, the Registrar and any Paying Agent may treat the Person in whose name any Certificate is registered (as of the day of determination) as the owner of such Certificate for the purpose of receiving distributions pursuant to Article IV and for all other purposes whatsoever, and none of the Trustee, the Registrar or any Paying Agent shall be affected by any notice to the contrary.

Section 3.08. Cancellation. All Certificates surrendered for payment or transfer or exchange shall, if surrendered to the Trustee or any agent of the Trustee other than the Registrar, be delivered to the Registrar for cancellation and shall promptly be cancelled by it. No Certificates shall be authenticated in lieu of or in exchange for any Certificates cancelled as provided in this Section 3.08, except as expressly permitted by this Agreement. All cancelled Certificates held by the Registrar shall be destroyed and a certification of their destruction delivered to the Trustee.

Section 3.09. Limitation of Liability for Payments. All payments and distributions made to Certificateholders of any series in respect of the Certificates of such series shall be made only from the Trust Property of the related Trust and only to the extent that the Trustee shall have sufficient income or proceeds from such Trust Property to make such payments in accordance with the terms of Article IV of this Agreement. Each Certificateholder, by its acceptance of a Certificate, agrees that it will look solely to the income and proceeds from the Trust Property of the related Trust for any payment or distribution due to such Certificateholder pursuant to the terms of this Agreement and that it will not have any recourse to the Company, the Trustee, the Loan Trustees, the Owner Trustees or the Owner Participants, except as otherwise expressly provided herein or in the related Intercreditor Agreement.

#### ARTICLE IV

##### DISTRIBUTIONS; STATEMENTS TO CERTIFICATEHOLDERS

Section 4.01. Certificate Account and Special Payments Account. (a) The Trustee shall establish and maintain on behalf of the Certificateholders of each series a Certificate Account as one or more non-interest-bearing accounts. The Trustee shall hold such Certificate Account in trust for the benefit of the Certificateholders of such series, and shall make or permit withdrawals therefrom only as provided in this Agreement. On each day when a Scheduled Payment is made to the Trustee (under an Intercreditor Agreement, if applicable) with respect to the Certificates of such series, the Trustee, upon receipt thereof, shall immediately deposit the aggregate amount of such Scheduled Payment in such Certificate Account.

(b) The Trustee shall establish and maintain on behalf of the Certificateholders of each series a Special Payments Account as one or more accounts, which shall be non-interest bearing except as provided in Section 4.04. The Trustee shall hold the Special Payments Account in trust for the benefit of the Certificateholders of such series and shall make or permit withdrawals therefrom only as provided in this Agreement. On each day when one or more Special Payments are made to the Trustee (under an Intercreditor Agreement, if applicable) with respect to the Certificates of such series, the Trustee, upon receipt thereof, shall immediately deposit the aggregate amount of such Special Payments in such Special Payments Account.

(c) The Trustee shall present (or, if applicable, cause the Subordination Agent to present) to the related Loan Trustee of each Equipment Note such Equipment Note on the date of its stated final maturity or, in the case of any Equipment Note which is to be redeemed in whole pursuant to the related Indenture, on the applicable redemption date under such Indenture.

Section 4.02. Distributions from Certificate Account and Special Payments Account. (a) On each Regular Distribution Date with respect to a series of Certificates or as soon thereafter as the Trustee has confirmed receipt of the payment of all or any part of the Scheduled Payments due on the Equipment Notes held (subject to the Intercreditor Agreement) in the related Trust on such date, the Trustee shall distribute out of the applicable Certificate Account the entire amount deposited therein pursuant to Section 4.01(a). There shall be so distributed to each Certificateholder of record of such series on the Record Date with respect to

such Regular Distribution Date (other than as provided in Section 11.01 concerning the final distribution) by check mailed to such Certificateholder, at the address appearing in the Register, such Certificateholder's pro rata share (based on the Fractional Undivided Interest in the Trust held by such Certificateholder) of the total amount in the applicable Certificate Account, except that, with respect to Certificates registered on the Record Date in the name of a Clearing Agency (or its nominee), such distribution shall be made by wire transfer in immediately available funds to the account designated by such Clearing Agency (or such nominee).

(b) On each Special Distribution Date with respect to any Special Payment with respect to a series of Certificates or as soon thereafter as the Trustee has confirmed receipt of any Special Payments due on the Equipment Notes held (subject to the Intercreditor Agreement) in the related Trust or realized upon the sale of such Equipment Notes, the Trustee shall distribute out of the applicable Special Payments Account the entire amount of such applicable Special Payment deposited therein pursuant to Section 4.01(b). There shall be so distributed to each Certificateholder of record of such series on the Record Date with respect to such Special Distribution Date (other than as provided in Section 11.01 concerning the final distribution) by check mailed to such Certificateholder, at the address appearing in the Register, such Certificateholder's pro rata share (based on the Fractional Undivided Interest in the related Trust held by such Certificateholder) of the total amount in the applicable Special Payments Account on account of such Special Payment, except that, with respect to Certificates registered on the Record Date in the name of a Clearing Agency (or its nominee), such distribution shall be made by wire transfer in immediately available funds to the account designated by such Clearing Agency (or such nominee).

(c) The Trustee shall, at the expense of the Company, cause notice of each Special Payment with respect to a series of Certificates to be mailed to each Certificateholder of such series at his address as it appears in the Register. In the event of redemption or purchase of Equipment Notes held in the related Trust, such notice shall be mailed not less than 15 days prior to the Special Distribution Date for the Special Payment resulting from such redemption or purchase, which Special Distribution Date shall be the date of such redemption or purchase. In the event that the Trustee receives a notice from the Company that Postponed Notes will, not be purchased by the Trustee pursuant to Section 2.02, such notice of Special Payment shall be mailed as soon as practicable after receipt of such notice from the Company and shall state the Special Distribution Date for such Special Payment, which shall occur 15 days after the date of such notice of Special Payment or (if such 15th day is not practicable) as soon as practicable thereafter. In the event that any Special Payment is to be made pursuant to the last paragraph of Section 2.02(b) hereof, there shall be mailed on the Cut-off Date (or, if such mailing on the Cut-off Date is not practicable, as soon as practicable after the Cut-off Date), notice of such Special Payment stating the Special Distribution Date for such Special Payment, which shall occur 15 days after the date of such notice of such Special Payment (or, if such 15th day is not practicable, as soon as practicable thereafter). In the case of any other Special Payments, such notice shall be mailed as soon as practicable after the Trustee has confirmed that it has received funds for such Special Payment, stating the Special Distribution Date for such Special Payment which shall occur not less than 15 days after the date of such notice and as soon as practicable thereafter. Notices mailed by the Trustee shall set forth:



- (i) the Special Distribution Date and the Record Date therefor (except as otherwise provided in Section 11.01),
- (ii) the amount of the Special Payment (taking into account any payment to be made by the Company pursuant to Section 2.02(b)) for each \$1,000 face amount Certificate and the amount thereof constituting principal, premium, if any, and interest,
- (iii) the reason for the Special Payment, and
- (iv) if the Special Distribution Date is the same date as a Regular Distribution Date for the Certificates of such series, the total amount to be received on such date for each \$1,000 face amount Certificate.

If the amount of premium, if any, payable upon the redemption or purchase of an Equipment Note has not been calculated at the time that the Trustee mails notice of a Special Payment, it shall be sufficient if the notice sets forth the other amounts to be distributed and states that any premium received will also be distributed.

If any redemption of the Equipment Notes held in any Trust is cancelled, the Trustee, as soon as possible after learning thereof, shall cause notice thereof to be mailed to each Certificateholder of the related series at its address as it appears on the Register.

Section 4.03. Statements to Certificateholders. (a) On each Regular Distribution Date and Special Distribution Date, the Trustee will include with each distribution of a Scheduled Payment or Special Payment, as the case may be, to Certificateholders of the related series a statement setting forth the information provided below. Such statement shall set forth (per \$1,000 aggregate face amount of Certificate as to (i) and (ii) below) the following information:

- (i) the amount of such distribution allocable to principal and the amount allocable to premium, if any;
- (ii) the amount of such distribution allocable to interest; and
- (iii) the Pool Balance and the Pool Factor of the related Trust.

With respect to the Certificates registered in the name of a Clearing Agency or its nominee, on the Record Date prior to each Distribution Date, the Trustee will request from the Clearing Agency a securities position listing setting forth the names of all the Clearing Agency Participants reflected on the Clearing Agency's books as holding interests in the Certificates on such Record Date. On each Distribution Date, the applicable Trustee will mail to each such Clearing Agency Participant the statement described above and will make available additional copies as requested by such Clearing Agency Participant for forwarding to holders of interests in the Certificates.

(b) Within a reasonable period of time after the end of each calendar year but not later than the latest date permitted by law, the Trustee shall furnish to each Person who at any time during such calendar year was a Certificateholder of record a statement containing the sum

of the amounts determined pursuant to clauses (a)(i) and (a)(ii) above with respect to the related Trust for such calendar year or, in the event such Person was a Certificateholder of record during a portion of such calendar year, for the applicable portion of such year, and such other items as are readily available to the Trustee and which a Certificateholder shall reasonably request as necessary for the purpose of such Certificateholder's preparation of its federal income tax returns. With respect to Certificates registered in the name of a Clearing Agency or its nominee, such statement and such other items shall be prepared on the basis of information supplied to the Trustee by the Clearing Agency Participants and shall be delivered by the Trustee to such Clearing Agency Participants to be available for forwarding by such Clearing Agency Participants to the holders of interests in the Certificates in the manner described in Section 4.03(a).

Section 4.04. Investment of Special Payment Moneys. Any money received by the Trustee pursuant to Section 4.01(b) representing a Special Payment which is not distributed on the date received shall, to the extent practicable, be invested in Permitted Investments by the Trustee pending distribution of such Special Payment pursuant to Section 4.02. Any investment made pursuant to this Section 4.04 shall be in such Permitted Investments having maturities not later than the date that such moneys are required to be used to make the payment required under Section 4.02 on the applicable Special Distribution Date and the Trustee shall hold any such Permitted Investments until maturity. The Trustee shall have no liability with respect to any investment made pursuant to this Section 4.04, other than by reason of the willful misconduct or negligence of the Trustee. All income and earnings from such investments shall be distributed on such Special Distribution Date as part of such Special Payment.

## ARTICLE V

### THE COMPANY

Section 5.01. Maintenance of Corporate Existence. The Company, at its own cost and expense, will do or cause to be done all things necessary to preserve and keep in full force and effect its corporate existence, rights and franchises, except as otherwise specifically permitted in Section 5.02; provided, however, that the Company shall not be required to preserve any right or franchise if the Company shall determine that the preservation thereof is no longer desirable in the conduct of the business of the Company.

Section 5.02. Consolidation, Merger, Etc. The Company shall not consolidate with or merge into any other Person or convey, transfer or lease substantially all of its assets as an entirety to any Person unless:

(a) the Person formed by such consolidation or into which the Company is merged or the Person that acquires by conveyance, transfer or lease substantially all of the assets of the Company as an entirety shall be (i) organized and validly existing under the laws of the United States of America or any state thereof or the District of Columbia, (ii) a "citizen of the United States" as defined in 49 U.S.C. § 40102(a)(15), as amended, and (iii) a United States certificated air carrier, if and so long as such status is a condition of entitlement to the benefits of Section 1110 of the Bankruptcy Reform Act of 1978, as amended (11 U.S.C. § 1110), with respect to the Leases or the Aircraft owned by the Company;

(b) the Person formed by such consolidation or into which the Company is merged or the Person which acquires by conveyance, transfer or lease substantially all of the assets of the Company as an entirety shall execute and deliver to the Trustee applicable to the Certificates of each series a duly authorized, valid, binding and enforceable agreement in form and substance reasonably satisfactory to the Trustee containing an assumption by such successor corporation or Person of the due and punctual performance and observance of each covenant and condition of the Note Documents and of this Agreement applicable to the Certificates of each series to be performed or observed by the Company; and

(c) the Company shall deliver to the Trustee an Officer's Certificate of the Company and an Opinion of Counsel of the Company reasonably satisfactory to the Trustee, each stating that such consolidation, merger, conveyance, transfer or lease and the assumption agreement mentioned in clause (b) above comply with this Section 5.02 and that all conditions precedent herein provided for relating to such transaction have been complied with.

Upon any consolidation or merger, or any conveyance, transfer or lease of substantially all of the assets of the Company as an entirety in accordance with this Section 5.02, the successor corporation or Person formed by such consolidation or into which the Company is merged or to which such conveyance, transfer or lease is made shall succeed to, and be substituted for, and may exercise every right and power of, the Company under this Agreement applicable to the Certificates of each series with the same effect as if such successor corporation or Person had been named as the Company herein. No such conveyance, transfer or lease of substantially all of the assets of the Company as an entirety shall have the effect of releasing any successor corporation or Person which shall have become such in the manner prescribed in this Section 5.02 from its liability in respect of this Agreement and any Note Document applicable to the Certificates of such series to which it is a party.

## ARTICLE VI

### DEFAULT

Section 6.01. Events of Default. (a) Exercise of Remedies. Upon the occurrence and during the continuation of any Indenture Event of Default under any Indenture, the Trustee may (i) to the extent it is the Controlling Party at such time (as determined pursuant to the related Intercreditor Agreement), direct the exercise of remedies as provided in such related Intercreditor Agreement and (ii) if there is no related Intercreditor Agreement, direct the exercise of remedies or take other action as provided in the relevant Indenture to the extent that it may do so as the holder of the Equipment Notes issued under such Indenture and held in the related Trust.

(b) Purchase Rights of Certificateholders. At any time after the occurrence and during the continuation of a Triggering Event, each Certificateholder of Certificates of

certain series (each, a “Potential Purchaser” and, collectively, the “Potential Purchasers”) will have certain rights to purchase the Certificates of one or more other series, all as set forth in the Trust Supplement applicable to the Certificates held by such Potential Purchaser. The purchase price with respect to the Certificates of any series shall be equal to the Pool Balance of the Certificates of such series, together with accrued and unpaid interest thereon to the date of such purchase, without premium, but including any other amounts then due and payable to the Certificateholders of such series under this Agreement, any related Intercreditor Agreement or any other Note Document or on or in respect of the Certificates of such series; provided, however, that if such purchase occurs after a Record Date, such purchase price shall be reduced by the amount to be distributed hereunder on the related Distribution Date (which deducted amounts shall remain distributable to, and may be retained by, the Certificateholder as of such Record Date); provided, further, that no such purchase of Certificates of such series shall be effective unless the purchasing Certificateholder (each, a “Purchasing Certificateholder” and, collectively, the “Purchasing Certificateholders”) shall certify to the Trustee that contemporaneously with such purchase, one or more Purchasing Certificateholders are purchasing, pursuant to the terms of this Agreement and the other Agreements, if any, relating to the Certificates of a series that are subject to the same Intercreditor Agreement (such other Agreements, the “Other Agreements”), the Certificates of each such series that the Trust Supplement applicable to the Certificates held by the Purchasing Certificateholder specifies may be purchased by such Purchasing Certificateholder. Each payment of the purchase price of the Certificates of any series shall be made to an account or accounts designated by the Trustee and each such purchase shall be subject to the terms of this Section 6.01. By acceptance of its Certificate, each Certificateholder (each, a “Selling Certificateholder” and, collectively, the “Selling Certificateholders”) of a series that is subject to purchase by Potential Purchasers, all as set forth in the Trust Supplement applicable to the Certificates held by the Selling Certificateholders, agrees that, at any time after the occurrence and during the continuance of a Triggering Event, it will, upon payment of the purchase price specified herein by one or more Purchasing Certificateholders, forthwith sell, assign, transfer and convey to such Purchasing Certificateholder (without recourse, representation or warranty of any kind except for its own acts), all of the right, title, interest and obligation of such Selling Certificateholder in this Agreement, any related Intercreditor Agreement, the related Liquidity Facility, the related Note Documents and all Certificates of such series held by such Selling Certificateholder (excluding - all right, title and interest under any of the foregoing to the extent such right, title or interest is with respect to an obligation not then due and payable as respects any action or inaction or state of affairs occurring prior to such sale) and the Purchasing Certificateholder shall assume all of such Selling Certificateholder’s obligations under this Agreement, any related Intercreditor Agreement, the related Liquidity Facility and the related Note Documents. The Certificates of such series will be deemed to be purchased on the date payment of the purchase price is made notwithstanding the failure of any Selling Certificateholder to deliver any Certificates of such series and, upon such a purchase, (i) the only rights of the Selling Certificateholders will be to deliver the Certificates to the Purchasing Certificateholder and receive the purchase price for such Certificates of such series and (ii) if the Purchasing Certificateholder shall so request, such Selling Certificateholder will comply with all of the provisions of Section 3.04 hereof to enable new Certificates of such series to be issued to the Purchasing Certificateholder in such denominations as it shall request. All charges and expenses in connection with the issuance of any such new Certificates shall be borne by the Purchasing Certificateholder.

Section 6.02. Incidents of Sale of Equipment Notes. Upon any sale of all or any part of the Equipment Notes held in the Trust made either under the power of sale given under this Agreement or otherwise for the enforcement of this Agreement, the following shall be applicable:

(1) Certificateholders and Trustee May Purchase Equipment Notes. Any Certificateholder, the Trustee in its individual or any other capacity or any other Person may bid for and purchase any of the Equipment Notes held in the Trust, and upon compliance with the terms of sale, may hold, retain, possess and dispose of such Equipment Notes in their own absolute right without further accountability.

(2) Receipt of Trustee Shall Discharge Purchaser. The receipt of the Trustee making such sale shall be a sufficient discharge to any purchaser for his purchase money, and, after paying such purchase money and receiving such receipt, such purchaser or its personal representative or assigns shall not be obliged to see to the application of such purchase money, or be in any way answerable for any loss, misapplication or non-application thereof.

(3) Application of Moneys Received upon Sale. Any moneys collected by the Trustee upon any sale made either under the power of sale given by this Agreement or otherwise for the enforcement of this Agreement shall be applied as provided in Section 4.02.

Section 6.03. Judicial Proceedings Instituted by Trustee; Trustee May Bring Suit. If there shall be a failure to make payment of the principal of, premium, if any, or interest on any Equipment Note held in the related Trust, or if there shall be any failure to pay Rent (as defined in the relevant Lease) under any Lease when due and payable, then the Trustee, in its own name and as trustee of an express trust, as holder of such Equipment Notes, to the extent permitted by and in accordance with the terms of any related Intercreditor Agreement and any related Note Documents (subject to rights of the applicable Owner Trustee or Owner Participant to cure any such failure to pay principal of, premium, if any, or interest on any Equipment Note or to pay Rent under any Lease in accordance with the applicable Indenture), shall be entitled and empowered to institute any suits, actions or proceedings at law, in equity or otherwise, for the collection of the sums so due and unpaid on such Equipment Notes or under such Lease and may prosecute any such claim or proceeding to judgment or final decree with respect to the whole amount of any such sums so due and unpaid.

Section 6.04. Control by Certificateholders. Subject to Section 6.03 and any related Intercreditor Agreement, the Certificateholders holding Certificates of a series evidencing Fractional Undivided Interests aggregating not less than a majority in interest in the related Trust shall have the right to direct the time, method and place of conducting any proceeding for any remedy available to the Trustee with respect to such Trust or pursuant to the terms of such Intercreditor Agreement, or exercising any trust or power conferred on the Trustee under this Agreement or such Intercreditor Agreement, including any right of the Trustee as Controlling Party under such Intercreditor Agreement or as holder of the Equipment Notes held in the related Trust; provided, however, that

(1) such Direction shall not in the opinion of the Trustee be in conflict with any rule of law or with this Agreement and would not involve the Trustee in personal liability or expense, unless the Person(s) issuing such Direction shall provide the Trustee with an indemnity against such liability or expense satisfactory to the Trustee in its sole discretion,

(2) the Trustee shall not determine that the action so directed would be unjustly prejudicial to the Certificateholders of such series not taking part in such Direction, and

(3) the Trustee may take any other action deemed proper by the Trustee which is not inconsistent with such Direction.

Section 6.05. Waiver of Past Defaults. Subject to any related Intercreditor Agreement, the Certificateholders holding Certificates of a series evidencing Fractional Undivided Interests aggregating not less than a majority in interest in the Trust (i) may on behalf of all of the Certificateholders waive any past Event of Default hereunder and its consequences or (ii) if the Trustee is the Controlling Party, may direct the Trustee to instruct the applicable Loan Trustee to waive any past Indenture Event of Default under any related Indenture and its consequences, and thereby annul any Direction given by such Certificateholders or the Trustee to such Loan Trustee with respect thereto, except a default:

(1) in the deposit of any Scheduled Payment or Special Payment under Section 4.01 or in the distribution of any payment under Section 4.02 on the Certificates of a series, or

(2) in the payment of the principal of (premium, if any) or interest on the Equipment Notes held in the related Trust, or

(3) in respect of a covenant or provision hereof which under Article IX hereof cannot be modified or amended without the consent of each Certificateholder holding an Outstanding Certificate of a series affected thereby.

Upon any such waiver, such default shall cease to exist with respect to the Certificates of such series and any Event of Default arising therefrom shall be deemed to have been cured for every purpose and any direction given by the Trustee on behalf of the Certificateholders of such series to the relevant Loan Trustee shall be annulled with respect thereto; but no such waiver shall extend to any subsequent or other default or Event of Default or impair any right consequent thereon. Upon any such waiver, the Trustee shall vote the Equipment Notes issued under the relevant Indenture to waive the corresponding Indenture Event of Default.

Section 6.06. Right of Certificateholders to Receive Payments Not to Be Impaired. Anything in this Agreement to the contrary notwithstanding, including, without limitation, Section 6.07 hereof, but subject to any related Intercreditor Agreement, the right of any Certificateholder to receive distributions of payments required pursuant to Section 4.02 hereof on the applicable Certificates when due, or to institute suit for the enforcement of any such payment on or after the applicable Regular Distribution Date or Special Distribution Date, shall not be impaired or affected without the consent of such Certificateholder.

Section 6.07. Certificateholders May Not Bring Suit Except Under Certain Conditions. A Certificateholder of any series shall not have the right to institute any suit, action or proceeding at law or in equity or otherwise with respect to this Agreement, for the appointment of a receiver or for the enforcement of any other remedy under this Agreement, unless:

(1) such Certificateholder previously shall have given written notice to the Trustee of a continuing Event of Default;

(2) Certificateholders holding Certificates of such series evidencing Fractional Undivided Interests aggregating not less than 25% of the related Trust shall have requested the Trustee in writing to institute such action, suit or proceeding and shall have offered to the Trustee indemnity as provided in Section 7.03(e);

(3) the Trustee shall have refused or neglected to institute any such action, suit or proceeding for 60 days after receipt of such notice, request and offer of indemnity; and

(4) no direction inconsistent with such written request shall have been given to the Trustee during such 60-day period by Certificateholders holding Certificates of such series evidencing Fractional Undivided Interests aggregating not less than a majority in interest in the related Trust.

It is understood and intended that no one or more of the Certificateholders of any series shall have any right in any manner whatsoever hereunder or under the related Trust Supplement or under the Certificates of such series to (i) surrender, impair, waive, affect, disturb or prejudice any property in the Trust Property of the related Trust, or the lien of any related Indenture on any property subject thereto, or the rights of the Certificateholders of such series or the holders of the related Equipment Notes, (ii) obtain or seek to obtain priority over or preference with respect to any other such Certificateholder of such series or (iii) enforce any right under this Agreement, except in the manner herein provided and for the equal, ratable and common benefit of all the Certificateholders of such series subject to the provisions of this Agreement.

Section 6.08. Remedies Cumulative. Every remedy given hereunder to the Trustee or to any of the Certificateholders of any series shall not be exclusive of any other remedy or remedies, and every such remedy shall be cumulative and in addition to every other remedy given hereunder or now or hereafter given by statute, law, equity or otherwise.

Section 6.09. Undertaking for Costs. In any suit for the enforcement of any right or remedy under this Agreement, or in any suit against the Trustee for any action taken, suffered or omitted by it as Trustee, a court may require any party litigant in such suit to file an undertaking to pay the costs of such suit, and may assess costs against any such party litigant, provided, however, that this Section 6.09 shall not be deemed to authorize any court to require such an undertaking or to make such an assessment in any suit instituted by the Company.

ARTICLE VII

THE TRUSTEE

Section 7.01. Certain Duties and Responsibilities. (a) Except during the continuance of an Event of Default in respect of a Trust, the Trustee undertakes to perform such duties in respect of such Trust as are specifically set forth in this Agreement, and no implied covenants or obligations shall be read into this Agreement against the Trustee.

(b) In case an Event of Default in respect of a Trust has occurred and is continuing, the Trustee shall exercise such of the rights and powers vested in it by this Agreement in respect of such Trust, and use the same degree of care and skill in their exercise, as a prudent man would exercise or use under the circumstances in the conduct of his own affairs.

(c) No provision of this Agreement shall be construed to relieve the Trustee from liability for its own negligent action, its own negligent failure to act, or its own willful misconduct, except that

(1) this Subsection shall not be construed to limit the effect of Subsection (a) of this Section 7.01; and

(2) the Trustee shall not be liable for any error of judgment made in good faith by a Responsible Officer of the Trustee, unless it shall be proved that the Trustee was negligent in ascertaining the pertinent facts.

(d) Whether or not herein expressly so provided, every provision of this Agreement relating to the conduct or affecting the liability of or affording protection to the Trustee shall be subject to the provisions of this Section 7.01.

Section 7.02. Notice of Defaults. As promptly as practicable after, and in any event within 90 days after, the occurrence of any default (as such term is defined below) hereunder known to the Trustee, the Trustee shall transmit by mail to the Company, any related Owner Trustees, any related Owner Participants, the related Loan Trustees and the Certificateholders holding Certificates of the related series, notice of such default hereunder known to the Trustee, unless such default shall have been cured or waived; provided, however, that, except in the case of a default in the payment of the principal, premium, if any, or interest on any Equipment Note, the Trustee shall be protected in withholding such notice if and so long as the board of directors, the executive committee or a trust committee of directors and/or Responsible Officers of the Trustee in good faith shall determine that the withholding of such notice is in the interests of the Certificateholders of the related series. For the purpose of this Section 7.02 in respect of any Trust, the term “default” means any event that is, or after notice or lapse of time or both would become, an Event of Default in respect of that Trust.

Section 7.03. Certain Rights of Trustee. The Trustee shall have the following rights:

(a) the Trustee may rely and shall be protected in acting or refraining from acting in reliance upon any resolution, certificate, statement, instrument, opinion, report, notice, request, direction, consent, order, bond, debenture or other paper or document believed by it to be genuine and to have been signed or presented by the proper party or parties;



(b) any request or direction of the Company mentioned herein shall be sufficiently evidenced by a Request;

(c) whenever in the administration of this Agreement or any Intercreditor Agreement, the Trustee shall deem it desirable that a matter be proved or established prior to taking, suffering or omitting any action hereunder, the Trustee (unless other evidence be herein specifically prescribed) may, in the absence of bad faith on its part, rely upon an Officer's Certificate of the Company, any related Owner Trustee or any related Loan Trustee;

(d) the Trustee may consult with counsel and the advice of such counsel or any Opinion of Counsel shall be full and complete authorization and protection in respect of any action taken, suffered or omitted by it hereunder in good faith and in reliance thereon;

(e) the Trustee shall be under no obligation to exercise any of the rights or powers vested in it by this Agreement or any Intercreditor Agreement at the Direction of any of the Certificateholders pursuant to this Agreement or any Intercreditor Agreement, unless such Certificateholders shall have offered to the Trustee reasonable security or indemnity against the cost, expenses and liabilities which might be incurred by it in compliance with such Direction;

(f) the Trustee shall not be bound to make any investigation into the facts or matters stated in any resolution, certificate, statement, instrument, opinion, report, notice, request, direction, consent, order, bond, debenture or other paper or document;

(g) the Trustee may execute any of the trusts or powers under this Agreement or any Intercreditor Agreement or perform any duties under this Agreement or any Intercreditor Agreement either directly or by or through agents or attorneys, and the Trustee shall not be responsible for any misconduct or negligence on the part of any agent or attorney appointed with due care by it under this Agreement or any Intercreditor Agreement;

(h) the Trustee shall not be liable with respect to any action taken or omitted to be taken by it in good faith in accordance with the Direction of the Certificateholders holding Certificates of any series evidencing Fractional Undivided Interests aggregating not less than a majority in interest in the related Trust relating to the time, method and place of conducting any proceeding for any remedy available to the Trustee, or exercising any trust or power conferred upon the Trustee, under this Agreement or any Intercreditor Agreement; and

(i) the Trustee shall not be required to expend or risk its own funds in the performance of any of its duties under this Agreement, or in the exercise of any of its rights or powers, if it shall have reasonable grounds for believing that repayment of such funds or adequate indemnity against such risk is not reasonably assured to it.

Section 7.04. Not Responsible for Recitals or Issuance of Certificates. The recitals contained herein and in the Certificates of each series, except the certificates of authentication, shall not be taken as the statements of the Trustee, and the Trustee assumes no responsibility for their correctness. Subject to Section 7.15, the Trustee makes no

representations as to the validity or sufficiency of this Basic Agreement, any Equipment Notes, any Intercreditor Agreement, the Certificates of any series, any Trust Supplement or any Note Documents, except that the Trustee hereby represents and warrants that this Basic Agreement has been, and each Trust Supplement, each Certificate, each Note Purchase Agreement and each Intercreditor Agreement of, or relating to, each series will be executed and delivered by one of its officers who is duly authorized to execute and deliver such document on its behalf.

Section 7.05. May Hold Certificates. The Trustee, any Paying Agent, Registrar or any of their Affiliates or any other agent, in their respective individual or any other capacity, may become the owner or pledgee of Certificates and, if applicable, may otherwise deal with the Company, any Owner Trustees or the Loan Trustees with the same rights it would have if it were not Trustee, Paying Agent, Registrar or such other agent.

Section 7.06. Money Held in Trust. Money held by the Trustee or the Paying Agent in trust under this Agreement need not be segregated from other funds except to the extent required herein or by law and neither the Trustee nor the Paying Agent shall have any liability for interest upon any such moneys except as provided for herein.

Section 7.07. Compensation and Reimbursement. The Company agrees:

(1) to pay, or cause to be paid, to the Trustee from time to time reasonable compensation for all services rendered by it hereunder (which compensation shall not be limited by any provision of law in regard to the compensation of a trustee of an express trust); and

(2) except as otherwise expressly provided herein or in any Trust Supplement, to reimburse, or cause to be reimbursed, the Trustee upon its request for all reasonable out-of-pocket expenses, disbursements and advances incurred or made by the Trustee in accordance with any provision of this Basic Agreement, any Trust Supplement or any Intercreditor Agreement (including the reasonable compensation and the expenses and disbursements of its agents and counsel), except any such expense, disbursement or advance as may be attributable to its negligence, willful misconduct or bad faith or as may be incurred due to the Trustee's breach of its representations and warranties set forth in Section 7.15; and

(3) to indemnify, or cause to be indemnified, the Trustee with respect to the Certificates of any series, pursuant to the particular sections of the Note Purchase Agreements specified in the related Trust Supplement.

The Trustee shall be entitled to reimbursement from, and shall have a lien prior to the Certificates of each series upon, all property and funds held or collected by the Trustee in its capacity as Trustee with respect to such series or the related Trust for any tax incurred without negligence, bad faith or willful misconduct, on its part, arising out of or in connection with the acceptance or administration of such Trust (other than any tax attributable to the Trustee's compensation for serving as such), including any costs and expenses incurred in contesting the imposition of any such tax. The Trustee shall notify the Company of any claim for any tax for which it may seek reimbursement. If the Trustee reimburses itself from the Trust Property of

such Trust for any such tax, it will mail a brief report within 30 days setting forth the amount of such tax and the circumstances thereof to all Certificateholders of such series as their names and addresses appear in the Register.

Section 7.08. Corporate Trustee Required; Eligibility. Each Trust shall at all times have a Trustee which shall have a combined capital and surplus of at least \$75,000,000 (or a combined capital and surplus in excess of \$5,000,000 and the obligations of which, whether now in existence or hereafter incurred, are fully and unconditionally guaranteed by a corporation organized and doing business under the laws of the United States, any state or territory thereof or of the District of Columbia and having a combined capital and surplus of at least \$75,000,000). If such corporation publishes reports of conditions at least annually, pursuant to law or to the requirements of federal, state, territorial or District of Columbia supervising or examining authority, then for the purposes of this Section 7.08 the combined capital and surplus of such corporation shall be deemed to be its combined capital and surplus as set forth in its most recent report of conditions so published.

In case at any time the Trustee shall cease to be eligible in accordance with the provisions of this Section 7.08 to act as Trustee of any Trust, the Trustee shall resign immediately as Trustee of such Trust in the manner and with the effect specified in Section 7.09.

Section 7.09. Resignation and Removal; Appointment of Successor. (a) No resignation or removal of the Trustee and no appointment of a successor Trustee of any Trust pursuant to this Article shall become effective until the acceptance of appointment by the successor Trustee under Section 7.10.

(b) The Trustee may resign at any time as Trustee of any or all Trusts by giving prior written notice thereof to the Company, the Authorized Agents, the related Owner Trustees and the related Loan Trustees. If an instrument of acceptance by a successor Trustee shall not have been delivered to the Company, the related Owner Trustees and the Trustee within 30 days after the giving of such notice of resignation, the resigning Trustee may petition any court of competent jurisdiction for the appointment of a successor Trustee.

(c) The Trustee may be removed at any time by Direction of the Certificateholders of the related series holding Certificates evidencing Fractional Undivided Interests aggregating not less than a majority in interest in such Trust delivered to the Trustee and to the Company, the related Owner Trustees and the related Loan Trustees.

(d) If at any time in respect of any Trust:

(1) the Trustee shall cease to be eligible under Section 7.08 and shall fail to resign after written request therefor by the Company or by any such Certificateholder; or

(2) the Trustee shall become incapable of acting or shall be adjudged a bankrupt or insolvent, or a receiver of the Trustee or of its property shall be appointed or any public officer shall take charge or control of the Trustee or of its property or affairs for the purpose of rehabilitation, conservation or liquidation;

then, in any case, (i) the Company may remove the Trustee or (ii) any Certificateholder of the related series who has been a *bona fide* Certificateholder for at least six months may, on behalf of itself and all others similarly situated, petition any court of competent jurisdiction for the removal of the Trustee and the appointment of a successor Trustee of such Trust.

(e) If a Responsible Officer of the Trustee shall obtain actual knowledge of an Avoidable Tax (as defined below) in respect of any Trust which has been or is likely to be asserted, the Trustee shall promptly notify the Company and shall, within 30 days of such notification, resign as Trustee of such Trust hereunder unless within such 30-day period the Trustee shall have received notice that the Company has agreed to pay such tax. The Company shall promptly appoint a successor Trustee of such Trust in a jurisdiction where there are no Avoidable Taxes. As used herein, an “Avoidable Tax” in respect of such Trust means a state or local tax: (i) upon (w) such Trust, (x) such Trust Property, (y) Certificateholders of such Trust or (z) the Trustee for which the Trustee is entitled to seek reimbursement from the Trust Property of such Trust, and (ii) which would be avoided if the Trustee were located in another state, or jurisdiction within a state, within the United States of America. A tax shall not be an Avoidable Tax in respect of any Trust if the Company or any Owner Trustee shall agree to pay, and shall pay, such tax.

(f) If the Trustee shall resign, be removed or become incapable of acting as Trustee of any Trust or if a vacancy shall occur in the office of the Trustee of any Trust for any cause, the Company shall promptly appoint a successor Trustee of such Trust. If, within one year after such resignation, removal or incapability, or other occurrence of such vacancy, a successor Trustee of such Trust shall be appointed by Direction of the Certificateholders of the related series holding Certificates of such series evidencing Fractional Undivided Interests aggregating not less than a majority in interest in such Trust delivered to the Company, the related Owner Trustees, the related Loan Trustee and the retiring Trustee, then the successor Trustee of such Trust so appointed shall, with the approval of the Company of such appointment, which approval shall not be unreasonably withheld, forthwith upon its acceptance of such appointment, become the successor Trustee of such Trust and supersede the successor Trustee of such Trust appointed as provided above. If no successor Trustee shall have been so appointed as provided above and accepted appointment in the manner hereinafter provided, the resigning Trustee or any Certificateholder who has been a *bona fide* Certificateholder of the related series for at least six months may, on behalf of himself and all others similarly situated, petition any court of competent jurisdiction for the appointment of a successor Trustee of such Trust.

(g) The successor Trustee of a Trust shall give notice of the resignation and removal of the Trustee and appointment of the successor Trustee by mailing written notice of such event by first-class mail, postage prepaid, to the Certificateholders of the related series as their names and addresses appear in the Register. Each notice shall include the name of such successor Trustee and the address of its Corporate Trust Office.

Section 7.10. Acceptance of Appointment by Successor. Every successor Trustee appointed hereunder shall execute and deliver to the Company and to the retiring Trustee with respect to any or all Trusts an instrument accepting such appointment, and thereupon the resignation or removal of the retiring Trustee with respect to such Trusts shall become effective and such successor Trustee, without any further act, deed or conveyance, shall become vested

with all the rights, powers, trusts and duties of the retiring Trustee; but, on request of the Company or the successor Trustee, such retiring Trustee shall execute and deliver an instrument transferring to such successor Trustee all such rights, powers and trusts of the retiring Trustee and shall duly assign, transfer and deliver to such successor Trustee all Trust Property held by such retiring Trustee in respect of such Trusts hereunder, subject nevertheless to its lien, if any, provided for in Section 7.07. Upon request of any such successor Trustee, the Company, the retiring Trustee and such successor Trustee shall execute and deliver any and all instruments containing such provisions as shall be necessary or desirable to transfer and confirm to, and for more fully and certainly vesting in, such successor Trustee all such rights, powers and trusts.

If a successor Trustee is appointed with respect to one or more (but not all) Trusts, the Company, the predecessor Trustee and each successor Trustee with respect to any Trust shall execute and deliver a supplemental agreement hereto which shall contain such provisions as shall be deemed necessary or desirable to confirm that all the rights, powers, trusts and duties of the predecessor Trustee with respect to the Trusts as to which the predecessor Trustee is not retiring shall continue to be vested in the predecessor Trustee, and shall add to or change any of the provisions of this Basic Agreement and the applicable Trust Supplements as shall be necessary to provide for or facilitate the administration of the Trusts hereunder by more than one Trustee, it being understood that nothing herein or in such supplemental agreement shall constitute such Trustees as co-Trustees of the same Trust and that each such Trustee shall be Trustee of separate Trusts.

No institution shall accept its appointment as a Trustee hereunder unless at the time of such acceptance such institution shall be qualified and eligible under this Article VII.

Section 7.11. Merger, Conversion, Consolidation or Succession to Business. Any corporation into which the Trustee may be merged or converted or with which it may be consolidated, or any corporation resulting from any merger, conversion or consolidation to which the Trustee shall be a party, or any corporation succeeding to all or substantially all of the corporate trust business of the Trustee, shall be the successor of the Trustee hereunder; provided, however, that such corporation shall be otherwise qualified and eligible under this Article VII, without the execution or filing of any paper or any further act on the part of any of the parties hereto. In case any Certificates shall have been executed or authenticated, but not delivered, by the Trustee then in office, any successor by merger, conversion or consolidation to such authenticating Trustee may adopt such execution or authentication and deliver the Certificates so executed or authenticated with the same effect as if such successor Trustee had itself executed or authenticated such Certificates.

Section 7.12. Maintenance of Agencies. (a) With respect to each series of Certificates, there shall at all times be maintained an office or agency in the location set forth in Section 12.04 where Certificates of such series may be presented or surrendered for registration of transfer or for exchange, and for payment thereof, and where notices and demands, to or upon the Trustee in respect of such Certificates or this Agreement may be served; provided, however, that, if it shall be necessary that the Trustee maintain an office or agency in another location with respect to the Certificates of any series (e.g., the Certificates of such series shall be represented by Definitive Certificates and shall be listed on a national securities exchange), the Trustee will make all reasonable efforts to establish such an office or agency. Written notice of the location

of each such other office or agency and of any change of location thereof shall be given by the Trustee to the Company, any Owner Trustees, the Loan Trustees (in the case of any Owner Trustee or Loan Trustee, at its address specified in the Note Documents or such other address as may be notified to the Trustee) and the Certificateholders of such series. In the event that no such office or agency shall be maintained or no such notice of location or of change of location shall be given, presentations and demands may be made and notices may be served at the Corporate Trust Office of the Trustee.

(b) There shall at all times be a Registrar and a Paying Agent hereunder with respect to the Certificates of each series. Each such Authorized Agent shall be a bank or trust company, shall be a corporation organized and doing business under the laws of the United States or any state, with a combined capital and surplus of at least \$75,000,000, or a corporation having a combined capital and surplus in excess of \$5,000,000, the obligations of which are guaranteed by a corporation organized and doing business under the laws of the United States or any state, with a combined capital and surplus of at least \$75,000,000, and shall be authorized under such laws to exercise corporate trust powers, subject to supervision by federal or state authorities. The Trustee shall initially be the Paying Agent and, as provided in Section 3.04, Registrar hereunder with respect to the Certificates of each series. Each Registrar shall furnish to the Trustee, at stated intervals of not more than six months, and at such other times as the Trustee may request in writing, a copy of the Register maintained by such Registrar.

(c) Any corporation into which any Authorized Agent may be merged or converted or with which it may be consolidated, or any corporation resulting from any merger, consolidation or conversion to which any Authorized Agent shall be a party, or any corporation succeeding to the corporate trust business of any Authorized Agent, shall be the successor of such Authorized Agent, if such successor corporation is otherwise eligible under this Section 7.12, without the execution or filing of any paper or any further act on the part of the parties hereto or such Authorized Agent or such successor corporation.

(d) Any Authorized Agent may at any time resign by giving written notice of resignation to the Trustee, the Company, any related Owner Trustees and the related Loan Trustees. The Company may, and at the request of the Trustee shall, at any time terminate the agency of any Authorized Agent by giving written notice of termination to such Authorized Agent and to the Trustee. Upon the resignation or termination of an Authorized Agent or in case at any time any such Authorized Agent shall cease to be eligible under this Section 7.12 (when, in either case, no other Authorized Agent performing the functions of such Authorized Agent shall have been appointed), the Company shall promptly appoint one or more qualified successor Authorized Agents, reasonably satisfactory to the Trustee, to perform the functions of the Authorized Agent which has resigned or whose agency has been terminated or who shall have ceased to be eligible under this Section 7.12. The Company shall give written notice of any such appointment made by it to the Trustee, any related Owner Trustees and the related Loan Trustees; and in each case the Trustee shall mail notice of such appointment to all Certificateholders of the related series as their names and addresses appear on the Register for such series.

(e) The Company agrees to pay, or cause to be paid, from time to time to each Authorized Agent reasonable compensation for its services and to reimburse it for its reasonable expenses.

Section 7.13. Money for Certificate Payments to Be Held in Trust. All moneys deposited with any Paying Agent for the purpose of any payment on Certificates shall be deposited and held in trust for the benefit of the Certificateholders entitled to such payment, subject to the provisions of this Section 7.13. Moneys so deposited and held in trust shall constitute a separate trust fund for the benefit of the Certificateholders with respect to which such money was deposited.

The Trustee may at any time, for the purpose of obtaining the satisfaction and discharge of this Agreement or for any other purpose, direct any Paying Agent to pay to the Trustee all sums held in trust by such Paying Agent, such sums to be held by the Trustee upon the same trusts as those upon which such sums were held by such Paying Agent; and, upon such payment by any Paying Agent to the Trustee, such Paying Agent shall be released from all further liability with respect to such money.

Section 7.14. Registration of Equipment Notes in Trustee's Name. Subject to the provisions of any Intercreditor Agreement, the Trustee agrees that all Equipment Notes to be purchased by any Trust and Permitted Investments, if any, shall be issued in the name of the Trustee as trustee for the applicable Trust or its nominee and held by the Trustee in trust for the benefit of the Certificateholders of such series, or, if not so held, the Trustee or its nominee shall be reflected as the owner of such Equipment Notes or Permitted Investments, as the case may be, in the register of the issuer of such Equipment Notes or Permitted Investments, as the case may be.

Section 7.15. Representations and Warranties of Trustee. The Trustee hereby represents and warrants that:

(a) the Trustee is a national banking association duly incorporated, validly existing, and in good standing under the laws of the United States;

(b) the Trustee has full power, authority and legal right to execute, deliver and perform this Agreement, any Intercreditor Agreement and the Note Purchase Agreements and has taken all necessary action to authorize the execution, delivery and performance by it of this Agreement, any Intercreditor Agreement and the Note Purchase Agreements;

(c) the execution, delivery and performance by the Trustee of this Agreement, any Intercreditor Agreement and the Note Purchase Agreements (i) will not violate any provision of any United States federal law or the law of the state of the United States where it is located governing the banking and trust powers of the Trustee or any order, writ, judgment, or decree of any court, arbitrator or governmental authority applicable to the Trustee or any of its assets, (ii) will not violate any provision of the articles of association or by-laws of the Trustee, and (iii) will not violate any provision of, or constitute, with or without notice or lapse of time, a default under, or result in the creation or imposition of any lien on any properties included in the Trust Property

pursuant to the provisions of any mortgage, indenture, contract, agreement or other undertaking to which it is a party, which violation, default or lien could reasonably be expected to have an adverse effect on the Trustee's performance or ability to perform its duties hereunder or thereunder or on the transactions contemplated herein or therein;

(d) the execution, delivery and performance by the Trustee of this Agreement, any Intercreditor Agreement and the Note Purchase Agreements will not require the authorization, consent, or approval of, the giving of notice to, the filing or registration with, or the taking of any other action in respect of, any governmental authority or agency of the United States or the state of the United States where it is located regulating the banking and corporate trust activities of the Trustee; and

(e) this Agreement, any Intercreditor Agreement and the Note Purchase Agreements have been duly executed and delivered by the Trustee and constitute the legal, valid and binding agreements of the Trustee, enforceable against it in accordance with their respective terms; provided, however, that enforceability may be limited by (i) applicable bankruptcy, insolvency, reorganization, moratorium or similar laws affecting the rights of creditors generally and (ii) general principles of equity.

Section 7.16. Withholding Taxes; Information Reporting. As to the Certificates of any series, the Trustee, as trustee of the related grantor trust created by this Agreement, shall exclude and withhold from each distribution of principal, premium, if any, and interest and other amounts due under this Agreement or under the Certificates of such series any and all withholding taxes applicable thereto as required by law. The Trustee agrees to act as such withholding agent and, in connection therewith, whenever any present or future taxes or similar charges are required to be withheld with respect to any amounts payable in respect of the Certificates of such series, to withhold such amounts and timely pay the same to the appropriate authority in the name of and on behalf of the Certificateholders of such series, that it will file any necessary withholding tax returns or statements when due, and that, as promptly as possible after the payment thereof, it will deliver to each such Certificateholder of such series appropriate documentation showing the payment thereof, together with such additional documentary evidence as such Certificateholders may reasonably request from time to time. The Trustee agrees to file any other information reports as it may be required to file under United States law.

Section 7.17. Trustee's Liens. The Trustee in its individual capacity agrees that it will, in respect of each Trust created by this Agreement, at its own cost and expense promptly take any action as may be necessary to duly discharge and satisfy in full any mortgage, pledge, lien, charge, encumbrance, security interest or claim ("Trustee's Liens") on or with respect to the Trust Property of such Trust which is attributable to the Trustee either (i) in its individual capacity and which is unrelated to the transactions contemplated by this Agreement or the related Note Documents or (ii) as Trustee hereunder or in its individual capacity and which arises out of acts or omissions which are not contemplated by this Agreement.

Section 7.18. Capacity in Which Acting. Without limitation of any representations, warranties or covenants in this Article VII or any representations or warranties of the Trustee in any Trust Supplement, the Trustee as so appointed hereunder and under any Trust Supplement) acts hereunder and under any Trust not in its individual capacity but solely as trustee except as expressly provided herein or in the related Trust Supplement.



## CERTIFICATEHOLDERS' LISTS AND REPORTS BY TRUSTEE

Section 8.01. The Company to Furnish Trustee with Names and Addresses of Certificateholders. The Company will furnish to the Trustee within 15 days after each Record Date with respect to a Scheduled Payment, and at such other times as the Trustee may request in writing within 30 days after receipt by the Company of any such request, a list, in such form as the Trustee may reasonably require, of all information in the possession or control of the Company as to the names and addresses of the Certificateholders of each series, in each case as of a date not more than 15 days prior to the time such list is furnished; provided, however, that so long as the Trustee is the sole Registrar for such series, no such list need be furnished; and provided further, however, that no such list need be furnished for so long as a copy of the Register is being furnished to the Trustee pursuant to Section 7.12.

Section 8.02. Preservation of Information; Communications to Certificateholders. The Trustee shall preserve, in as current a form as is reasonably practicable, the names and addresses of Certificateholders of each series contained in the most recent list furnished to the Trustee as provided in Section 7.12 or Section 8.01, as the case may be, and the names and addresses of Certificateholders of each series received by the Trustee in its capacity as Registrar, if so acting. The Trustee may destroy any list furnished to it as provided in Section 7.12 or Section 8.01, as the case may be, upon receipt of a new list so furnished.

Section 8.03. Reports by the Company.

(a) The Company shall deliver to the Trustee:

(1) in respect of each financial year, audited financial statements of the Company which are prepared in accordance with GAAP which represent fairly and accurately in all material respects the financial position of the Company as at the end of the financial year and results of operations and cash flows for the period then ended; and deliver to the Trustee a copy of such financial statements as soon as practicable but not later than 120 days after the end of the financial year to which they relate;

(2) in respect of each quarterly period in each financial year (except the fourth), unaudited (or audited, if available) financial statements of the Company which are prepared in accordance with GAAP which represent fairly and accurately in all material respects the financial position of the Company as at the end of such quarterly period and results of operations and cash flows for the period then ended; and deliver to the Trustee a copy of such financial statements as soon as practicable but not later than 60 days after the end of the quarterly period to which they relate; and

(3) in lieu of delivering to the Trustee the financial statements referred to in clauses (i) and (ii) above, the Company may cause such financial statements to be publicly available on the internet within the time period set forth in clauses (i) and (ii) above, respectively, at a location identified to Trustee in writing.

(b) The Trustee shall provide copies of financial information filed with it pursuant to Section 8.03(a) to Certificateholders upon their request but shall not otherwise release such financial information without the consent of the Company.

## ARTICLE IX

### SUPPLEMENTAL AGREEMENTS

Section 9.01. Supplemental Agreements Without Consent of Certificateholders. Without the consent of the Certificateholders, the Company may (but will not be required to), and the Trustee (subject to Section 9.03) shall, at the Company's request, at any time and from time to time, enter into one or more agreements supplemental hereto or, if applicable, to an Intercreditor Agreement or a Liquidity Facility, in form satisfactory to the Trustee, for any of the following purposes:

(1) to provide for the formation of a Trust, the issuance of a series of Certificates and other matters contemplated by Section 2.01(b); or

(2) to evidence the succession of another corporation to the Company and the assumption by any such successor of the covenants of the Company herein contained or of the Company's obligations under any Intercreditor Agreement or any Liquidity Facility; or

(3) to add to the covenants of the Company for the benefit of the Certificateholders of any series, or to surrender any right or power conferred upon the Company in this Agreement, any Intercreditor Agreement or any Liquidity Facility; or

(4) to correct or supplement any provision in this Agreement, any Intercreditor Agreement or any Liquidity Facility which may be defective or inconsistent with any other provision herein or therein or to cure any ambiguity or to modify any other provision with respect to matters or questions arising under this Agreement, any Intercreditor Agreement or any Liquidity Facility, provided, however, that any such action shall not materially adversely affect the interests of the Certificateholders of any series; to correct any mistake in this Agreement, any Intercreditor Agreement or any Liquidity Facility; or, as provided in any Intercreditor Agreement, to give effect to or provide for a Replacement Liquidity Facility (as defined in such Intercreditor Agreement); or

(5) to comply with any requirement of the SEC, any applicable law, rules or regulations of any exchange or quotation system on which the Certificates of any series are listed or of any regulatory body; or

(6) [intentionally omitted]; or

(7) to evidence and provide for the acceptance of appointment under this Agreement, any Intercreditor Agreement or any Liquidity Facility by a successor Trustee with respect to one or more Trusts and to add to or change any of the provisions of this Agreement, any Intercreditor Agreement or any Liquidity Facility as shall be necessary to provide for or facilitate the administration of the Trust, pursuant to the requirements of Section 7.10; or

(8) to provide the information required under Section 7.12 and Section 12.04 as to the Trustee; or

(9) to make any other amendments or modifications hereto, provided, however, that such amendments or modifications shall apply to Certificates of any series to be thereafter issued;

provided, however, that no such supplemental agreement shall adversely affect the status of any Trust as a grantor trust under Subpart E, Part I of Subchapter J of Chapter 1 of Subtitle A of the Internal Revenue Code of 1986, as amended, for U.S. federal income tax purposes.

Section 9.02. Supplemental Agreements with Consent of Certificateholders. With respect to each separate Trust and the series of Certificates relating thereto, with the consent of the Certificateholders holding Certificates of such series (including consents obtained in connection with a consent solicitation, tender offer or exchange offer for the Certificates) evidencing Fractional Undivided Interests aggregating not less than a majority in interest in such Trust, by Direction of said Certificateholders delivered to the Company and the Trustee, the Company may (with the consent of the Owner Trustees, if any, relating to such Certificates, which consent shall not be unreasonably withheld), but shall not be obligated to, and the Trustee (subject to Section 9.03) shall, enter into an agreement or agreements supplemental hereto for the purpose of adding any provisions to or changing in any manner or eliminating any of the provisions of this Agreement, any Intercreditor Agreement or any Liquidity Facility to the extent applicable to such Certificateholders or of modifying in any manner the rights and obligations of such Certificateholders under this Agreement, any Intercreditor Agreement or any Liquidity Facility; provided, however, that no such agreement shall, without the consent of the Certificateholder of each Outstanding Certificate affected thereby:

(1) reduce in any manner the amount of, or delay the timing of, any receipt by the Trustee of payments on the Equipment Notes held in such Trust or distributions that are required to be made herein on any Certificate of such series, or change any date of payment on any Certificate of such series, or change the place of payment where, or the coin or currency in which, any Certificate of such series is payable, or impair the right to institute suit for the enforcement of any such payment or distribution on or after the Regular Distribution Date or Special Distribution Date applicable thereto; or

(2) permit the disposition of any Equipment Note included in the Trust Property of such Trust except as permitted by this Agreement, or otherwise deprive such Certificateholder of the benefit of the ownership of the Equipment Notes in such Trust; or

(3) alter the priority of distributions specified in the Intercreditor Agreement in a manner materially adverse to the interests of the Certificateholders of any series; or

(4) reduce the specified percentage of the aggregate Fractional Undivided Interests of such Trust that is required for any such supplemental agreement, or reduce such specified percentage required for any waiver (of compliance with certain provisions of this Agreement or certain defaults hereunder and their consequences) provided for in this Agreement; or

(5) modify any of the provisions of this Section 9.02 or Section 6.05, except to increase any such percentage or to provide that certain other provisions of this Agreement cannot be modified or waived without the consent of the Certificateholder of each Certificate of such series affected thereby; or

(6) adversely affect the status of any Trust as a grantor trust under Subpart E, Part I of Subchapter J of Chapter 1 of Subtitle A of the Internal Revenue Code of 1986, as amended, for U.S. federal income tax purposes.

It shall not be necessary for any Direction of such Certificateholders under this Section 9.02 to approve the particular form of any proposed supplemental agreement, but it shall be sufficient if such Direction shall approve the substance thereof.

Section 9.03. Documents Affecting Immunity or Indemnity. If in the opinion of the Trustee any document required to be executed by it pursuant to the terms of Section 9.01 or 9.02 affects any interest, right, duty, immunity or indemnity in favor of the Trustee under this Basic Agreement or any Trust Supplement, the Trustee may in its discretion decline to execute such document.

Section 9.04. Execution of Supplemental Agreements. In executing, or accepting the additional trusts created by, any supplemental agreement permitted by this Article or the modifications thereby of the trusts created by this Agreement, the Trustee shall be entitled to receive, and shall be fully protected in relying upon, an Opinion of Counsel stating that the execution of such supplemental agreement is authorized or permitted by this Agreement.

Section 9.05. Effect of Supplemental Agreements. Upon the execution of any agreement supplemental to this Agreement under this Article, this Basic Agreement shall be modified in accordance therewith, and such supplemental agreement shall form a part of this Basic Agreement for all purposes; and every Certificateholder of each series theretofore or thereafter authenticated and delivered hereunder shall be bound thereby to the extent applicable to such series.

Section 9.06. Reference in Certificates to Supplemental Agreements. Certificates of each series authenticated and delivered after the execution of any supplemental agreement applicable to such series pursuant to this Article may bear a notation in form approved by the Trustee as to any matter provided for in such supplemental agreement; and, in such case, suitable notation may be made upon Outstanding Certificates of such series after proper presentation and demand.

## AMENDMENTS TO INDENTURE AND NOTE DOCUMENTS

Section 10.01. Amendments and Supplements to Indenture and Other Note Documents. In the event that the Trustee, as holder (or beneficial owner through the Subordination Agent) of any Equipment Notes (or as a prospective purchaser of any Postponed Notes) in trust for the benefit of the Certificateholders of any series or as Controlling Party under an Intercreditor Agreement, receives (directly or indirectly through the Subordination Agent) a request for a consent to any amendment, modification, waiver or supplement under any Indenture, other Note Document or any other related document, the Trustee shall forthwith send a notice of such proposed amendment, modification, waiver or supplement to each Certificateholder of such series registered on the Register as of the date of such notice. The Trustee shall request from the Certificateholders of such series a Direction as to (a) whether or not to take or refrain from taking (or direct the Subordination Agent to take or refrain from taking) any action which a holder of (or, with respect to Postponed Notes, a prospective purchaser of) such Equipment Note or a Controlling Party has the option to direct, (b) whether or not to give or execute (or direct the Subordination Agent to give or execute) any waivers, consents, amendments, modifications or supplements as a holder of (or, with respect to Postponed Notes, a prospective purchaser of) such Equipment Note or as Controlling Party and (c) how to vote (or direct the Subordination Agent to vote) any Equipment Note (or, with respect to a Postponed Note, its commitment to acquire such Postponed Note) if a vote has been called for with respect thereto. Provided such a request for Certificateholder Direction shall have been made, in directing any action or casting any vote or giving any consent as the holder of any Equipment Note (or in directing the Subordination Agent in any of the foregoing), (i) other than as Controlling Party, the Trustee shall vote for or give consent to any such action with respect to such Equipment Note (or Postponed Note) in the same proportion as that of (A) the aggregate face amounts of all Certificates actually voted in favor of or for giving consent to such action by such Direction of Certificateholders to (B) the aggregate face amount of all Outstanding Certificates and (ii) as Controlling Party, the Trustee shall vote as directed in such Certificateholder Direction by the Certificateholders of such series evidencing a Fractional Undivided Interest aggregating not less than a majority in interest in the Trust. For purposes of the immediately preceding sentence, a Certificate shall have been "actually voted" if the Holder of such Certificate has delivered to the Trustee an instrument evidencing such Holder's consent to such Direction prior to one Business Day before the Trustee directs such action or casts such vote or gives such consent. Notwithstanding the foregoing, but subject to Section 6.04 and any Intercreditor Agreement, the Trustee may, with respect to the Certificates of any series, in its own discretion and at its own direction, consent and notify the relevant Loan Trustee of such consent (or direct the Subordination Agent to consent and notify the Loan Trustee of such consent) to any amendment, modification, waiver or supplement under any related Indenture or any other related Note Document if an Event of Default hereunder shall have occurred and be continuing or if such amendment, modification, waiver or supplement will not materially adversely affect the interests of the Certificateholders of such series.

## TERMINATION OF TRUSTS

Section 11.01. Termination of the Trusts. In respect of each Trust created by this Basic Agreement as supplemented by a related Trust Supplement, the respective obligations and responsibilities of the Company and the Trustee with respect to such Trust shall terminate upon the distribution to all Holders of Certificates of the series of such Trust and the Trustee of all amounts required to be distributed to them pursuant to this Agreement and the disposition of all property held as part of the Trust Property of such Trust; provided, however, that in no event shall such Trust continue beyond one hundred ten (110) years following the date of the execution of the Trust Supplement with respect to such Trust (or such other final expiration date as may be specified in such Trust Supplement).

Notice of any termination of a Trust, specifying the applicable Regular Distribution Date (or applicable Special Distribution Date, as the case may be) upon which the Certificateholders of any series may surrender their Certificates to the Trustee for payment of the final distribution and cancellation, shall be mailed promptly by the Trustee to Certificateholders of such series not earlier than the minimum number of days and not later than the maximum number of days specified therefor in the related Trust Supplement preceding such final distribution specifying (A) the Regular Distribution Date (or Special Distribution Date, as the case may be) upon which the proposed final payment of the Certificates of such series will be made upon presentation and surrender of Certificates of such series at the office or agency of the Trustee therein specified, (B) the amount of any such proposed final payment, and (C) that the Record Date otherwise applicable to such Regular Distribution Date (or Special Distribution Date, as the case may be) is not applicable, payments being made only upon presentation and surrender of the Certificates of such series at the office or agency of the Trustee therein specified. The Trustee shall give such notice to the Registrar at the time such notice is given to Certificateholders of such series. Upon presentation and surrender of the Certificates of such series in accordance with such notice, the Trustee shall cause to be distributed to Certificateholders of such series amounts distributable on such Regular Distribution Date (or Special Distribution Date, as the case may be) pursuant to Section 4.02.

In the event that all of the Certificateholders of such series shall not surrender their Certificates for cancellation within six months after the date specified in the above-mentioned written notice, the Trustee shall give a second written notice to the remaining Certificateholders of such series to surrender their Certificates for cancellation and receive the final distribution with respect thereto. No additional interest shall accrue on the Certificates of such series after any Regular Distribution Date (or Special Distribution Date, as the case may be) of such series, as specified in the first written notice. In the event that any money held by the Trustee for the payment of distributions on the Certificates of such series shall remain unclaimed for two years (or such lesser time as the Trustee shall be satisfied, after 60 days' notice from the Company, is one month prior to the escheat period provided under applicable law) after the final distribution date with respect thereto, the Trustee shall pay to each Loan Trustee the appropriate amount of money relating to such Loan Trustee and shall give written notice thereof to the related Owner Trustees and the Company.

ARTICLE XII

MISCELLANEOUS PROVISIONS

Section 12.01. Limitation on Rights of Certificateholders. The death or incapacity of any Certificateholder of any series shall not operate to terminate this Agreement or the related Trust, nor entitle such Certificateholder's legal representatives or heirs to claim an accounting or to take any action or commence any proceeding in any court for a partition or winding up of the Trust, nor otherwise affect the rights, obligations, and liabilities of the parties hereto or any of them.

Section 12.02. Liabilities of Certificateholders. Neither the existence of the Trust nor any provision in this Agreement is intended to or shall limit the liability the Certificateholders would otherwise incur if the Certificateholders owned Trust Property as co- owners, or incurred any obligations of the Trust, directly rather than through the Trust.

Section 12.03. Registration of Equipment Notes in Name of Subordination Agent. If a Trust is party to an Intercreditor Agreement, the Trustee agrees that all Equipment Notes to be purchased by such Trust shall be issued in the name of the Subordination Agent under such Intercreditor Agreement or its nominee and held by such Subordination Agent in trust for the benefit of the Certificateholders, or, if not so held, such Subordination Agent or its nominee shall be reflected as the owner of such Equipment Notes in the register of the issuer of such Equipment Notes.

Section 12.04. Notices. (a) Unless otherwise specifically provided herein or in the applicable Trust Supplement with respect to any Trust, all notices required under the terms and provisions of this Basic Agreement or such Trust Supplement with respect to such Trust shall be in English and in writing, and any such notice may be given by United States mail, courier service or telecopy, and any such notice shall be effective when delivered or received **or**, if mailed, three days after deposit in the United States mail with proper postage for ordinary mail prepaid,

if to the Company:

Sun Country, Inc.  
2005 Cargo Road  
Minneapolis, Minnesota 55450  
Facsimile: (612) 977-2778  
Attn: Treasurer

if to the Trustee:

Wilmington Trust, National Association  
1100 North Market Street  
Wilmington, Delaware 19890  
Facsimile: (302) 636-4140  
Attn: Corporate Trust Administration

(b) The Company or the Trustee, by notice to the other, may designate additional or different addresses for subsequent notices or communications.

(c) Any notice or communication to Certificateholders of any series shall be mailed by first-class mail to the addresses for Certificateholders of such series shown on the Register kept by the Registrar and to addresses filed with the Trustee for Certificate Owners of such series. Failure so to mail a notice or communication or any defect in such notice or communication shall not affect its sufficiency with respect to other Certificateholders or Certificate Owners of such series.

(d) If a notice or communication is mailed in the manner provided above within the time prescribed, it is conclusively presumed to have been duly given, whether or not the addressee receives it.

(e) If the Company mails a notice or communication to the Certificateholders of such series, it shall mail a copy to the Trustee and to each Paying Agent for such series at the same time.

(f) Notwithstanding the foregoing, all communications or notices to the Trustee shall be deemed to be given only when received by a Responsible Officer of the Trustee.

(g) The Trustee shall promptly furnish the Company with a copy of any demand, notice or written communication received by the Trustee hereunder from any Certificateholder, Owner Trustee or Loan Trustee.

Section 12.05. Governing Law. THIS BASIC AGREEMENT HAS BEEN DELIVERED IN THE STATE OF NEW YORK AND, TOGETHER WITH ALL TRUST SUPPLEMENTS AND CERTIFICATES, SHALL BE CONSTRUED IN ACCORDANCE WITH THE LAWS OF THE STATE OF NEW YORK AND THE OBLIGATIONS, RIGHTS AND REMEDIES OF THE PARTIES HEREUNDER SHALL BE DETERMINED IN ACCORDANCE WITH SUCH LAWS.

Section 12.06. Severability of Provisions. If any one or more of the covenants, agreements, provisions or terms of this Agreement shall be for any reason whatsoever held invalid, then such covenants, agreements, provisions, or terms shall be deemed severable from the remaining covenants, agreements, provisions or terms of this Agreement and shall in no way affect the validity or enforceability of the other provisions of this Agreement or the related Trust, or of the Certificates of such series or the rights of the Certificateholders thereof.

Section 12.07. Effect of Headings and Table of Contents. The Article and Section headings herein and the Table of Contents are for convenience only and shall not affect the construction hereof.

Section 12.08. Successors and Assigns. All covenants, agreements, representations and warranties in this Agreement by the Trustee and the Company shall bind and, to the extent permitted hereby, shall inure to the benefit of and be enforceable by their respective successors and assigns, whether so expressed or not.



Section 12.09. Benefits of Agreement. Nothing in this Agreement or in the Certificates of any series, express or implied, shall give to any Person, other than the parties hereto and their successors hereunder, and the Certificateholders of each series, any benefit or any legal or equitable right, remedy or claim under this Agreement.

Section 12.10. Legal Holidays. In any case where any Regular Distribution Date or Special Distribution Date relating to any Certificate of any series shall not be a Business Day with respect to such series, then (notwithstanding any other provision of this Agreement) payment need not be made on such date, but may be made on the next succeeding Business Day with the same force and effect as if made on such Regular Distribution Date or Special Distribution Date, and no interest shall accrue during the intervening period.

Section 12.11. Counterparts. For the purpose of facilitating the execution of this Agreement and for other purposes, this Agreement may be executed simultaneously in any number of counterparts, each of which counterparts shall be deemed to be an original, and all of which counterparts shall constitute but one and the same instrument.

Section 12.12. Intention of Parties. The parties hereto intend that each Trust be classified for U.S. federal income tax purposes as a grantor trust under Subpart E, Part I of Subchapter J of the Internal Revenue Code of 1986, as amended, and not as a trust or association taxable as a corporation or as a partnership. The powers granted and obligations undertaken pursuant to this Agreement shall be so construed so as to further such intent.

IN WITNESS WHEREOF, the parties have caused this Agreement to be duly executed by their respective officers thereunto duly authorized as of the day and year first written above.

SUN COUNTRY, INC.

By: /s/ Jude Bricker

Name Jude Bricker

Title Chief Financial Officer

WILMINGTON TRUST, NATIONAL ASSOCIATION,  
as Trustee

By: /s/ Chad May

Name Chad May

Title Vice President

## EXHIBIT A

## FORM OF CERTIFICATE

Certificate  
No. \_\_\_\_

PPN No: [ ]

SUN COUNTRY PASS THROUGH TRUST 2019-1A

Sun Country Pass Through Certificate, Series 2019-1A  
Issuance Date: [\_\_\_\_], 2019

Final Legal Distribution Date: June 15, 2029

Evidencing A Fractional Undivided Interest In The Sun Country Pass Through Trust 2019-1A, The Property Of Which Shall Include Certain  
Equipment Notes Each Secured By An Aircraft Owned By Sun Country, Inc.\$[\_\_\_\_\_] Fractional Undivided Interest  
representing .[\_\_\_\_]% of the Trust per \$1,000 face amount

THIS CERTIFIES THAT \_\_\_\_\_, for value received, is the registered owner of a \$\_\_\_\_\_ (\_\_\_\_\_ DOLLARS) Fractional Undivided Interest in the Sun Country Pass Through Trust 2019-1A (the "Trust") created by Wilmington Trust, National Association, as trustee (the "Trustee"), pursuant to a Pass Through Trust Agreement, dated as of December 9, 2019 (the "Basic Agreement"), between the Trustee and Sun Country, Inc., a Minnesota corporation (the "Company"), as supplemented by Trust Supplement No. 2019-1A thereto, dated as of December 9, 2019 (the "Trust Supplement") and, together with the Basic Agreement, the "Agreement"), between the Trustee and the Company, a summary of certain of the pertinent provisions of which is set forth below. To the extent not otherwise defined herein, the capitalized terms used herein have the meanings assigned to them in the Agreement. This Certificate is one of the duly authorized Certificates designated as "Sun Country Pass Through Certificates, Series 2019-1A" (herein called the "Certificates"). This Certificate is issued under and is subject to the terms, provisions and conditions of the Agreement. By virtue of its acceptance hereof, the holder of this Certificate (the "Certificateholder" and, together with all other holders of Certificates issued by the Trust, the "Certificateholders") assents to and agrees to be bound by the provisions of the Agreement and the Intercreditor Agreement. The property of the Trust includes certain Equipment Notes, and all rights of the Trust to receive payments under the Intercreditor Agreement (the "Trust Property"). Each issue of the Equipment Notes is secured by, among other things, a security interest in an Aircraft owned by the Company.

[AS OF THE DATE OF ISSUANCE OF THIS CERTIFICATE AND THROUGH THE OCCURRENCE OF THE FINAL PREFUNDING EXPIRY DATE (AND DISTRIBUTION OF ANY AMOUNTS IN RELATION THERETO PURSUANT TO THE CERTIFICATE PURCHASE AGREEMENT), THE FACE AMOUNT AND FRACTIONAL UNDIVIDED INTEREST SET FORTH ABOVE IN THIS CERTIFICATE REMAIN SUBJECT

TO ADJUSTMENT PURSUANT TO, AND THIS CERTIFICATE IS SUBJECT TO THE ADDITIONAL RESTRICTIONS ON TRANSFER SET FORTH IN, SECTION 3.07 OF THE TRUST SUPPLEMENT. THE ACTUAL FACE AMOUNT AND FRACTIONAL UNDIVIDED INTEREST REPRESENTED BY THIS CERTIFICATE, TAKING INTO ACCOUNT ANY SUCH ADJUSTMENTS, SHALL BE AS SET FORTH IN THE RECORDS MAINTAINED BY THE TRUSTEE PURSUANT TO SECTION 3.07 OF THE TRUST SUPPLEMENT.]<sup>1</sup>

The Certificates represent Fractional Undivided Interests in the Trust and the Trust Property and have no rights, benefits or interest in respect of any other separate trust established pursuant to the terms of the Basic Agreement for any other series of certificates issued pursuant thereto.

Subject to and in accordance with the terms of the Agreement and the Intercreditor Agreement, from funds then available to the Trustee, there will be distributed on June 15 and December 15 of each year (a "Regular Distribution Date") commencing June 15, 2020, to the Person in whose name this Certificate is registered at the close of business on the 15th day preceding the Regular Distribution Date, an amount in respect of the Scheduled Payments on the Equipment Notes due on such Regular Distribution Date, the receipt of which has been confirmed by the Trustee, equal to the product of the percentage interest in the Trust evidenced by this Certificate and an amount equal to the sum of such Scheduled Payments. Subject to and in accordance with the terms of the Agreement and the Intercreditor Agreement, in the event that Special Payments on the Equipment Notes are received by the Trustee, from funds then available to the Trustee, there shall be distributed on the applicable Special Distribution Date, to the Person in whose name this Certificate is registered at the close of business on the 15th day preceding the Special Distribution Date, an amount in respect of such Special Payments on the Equipment Notes, the receipt of which has been confirmed by the Trustee, equal to the product of the percentage interest in the Trust evidenced by this Certificate and an amount equal to the sum of such Special Payments so received. If a Regular Distribution Date or Special Distribution Date is not a Business Day, distribution shall be made on the immediately following Business Day with the same force and effect as if made on such Regular Distribution Date or Special Distribution Date and no interest shall accrue during the intervening period. The Trustee shall mail notice of each Special Payment and the Special Distribution Date therefor to the Certificateholder of this Certificate.

Distributions on this Certificate will be made by the Trustee by check mailed to the Person entitled thereto, without presentation or surrender of this Certificate or the making of any notation hereon. Except as otherwise provided in the Agreement and notwithstanding the above, the final distribution on this Certificate will be made after notice mailed by the Trustee of the pendency of such distribution and only upon presentation and surrender of this Certificate at the office or agency of the Trustee specified in such notice.

---

<sup>1</sup> This Section 3.07 Paragraph should be included in each Applicable Certificate issued prior to the Final Prefunding Expiry Date. This 3.07 Paragraph should be omitted from Applicable Certificates issued after the Final Prefunding Expiry Date (each of which should each be issued in the applicable face amounts and reflecting Fractional Undivided Interests after taking into account all applicable adjustments pursuant to Section 3.07 of the Trust Supplement).

The Certificates do not represent a direct obligation of, or an obligation guaranteed by, or an interest in, the Company or the Trustee or any affiliate thereof. The Certificates are limited in right of payment, all as more specifically set forth on the face hereof and in the Agreement. All payments or distributions made to Certificateholders under the Agreement shall be made only from the Trust Property and only to the extent that the Trustee shall have sufficient income or proceeds from the Trust Property to make such payments in accordance with the terms of the Agreement. Each Certificateholder of this Certificate, by its acceptance hereof, agrees that it will look solely to the income and proceeds from the Trust Property to the extent available for distribution to such Certificateholder as provided in the Agreement. This Certificate does not purport to summarize the Agreement and reference is made to the Agreement for information with respect to the interests, rights, benefits, obligations, privileges, and duties evidenced hereby. A copy of the Agreement may be examined during normal business hours at the principal office of the Trustee, and at such other places, if any, designated by the Trustee, by any Certificateholder upon request.

The Agreement permits, with certain exceptions therein provided, the amendment thereof and the modification of the rights and obligations of the Company and the rights of the Certificateholders under the Agreement at any time by the Company and the Trustee with the consent of the Certificateholders holding Certificates evidencing Fractional Undivided Interests aggregating not less than a majority in interest in the Trust. Any such consent by the Certificateholder of this Certificate shall be conclusive and binding on such Certificateholder and upon all future Certificateholders of this Certificate and of any Certificate issued upon the transfer hereof or in exchange hereof or in lieu hereof whether or not notation of such consent is made upon this Certificate. The Agreement also permits the amendment thereof, in certain limited circumstances, without the consent of the Certificateholders of any of the Certificates.

As provided in the Agreement and subject to certain limitations set forth therein, the transfer of this Certificate is registrable in the Register upon surrender of this Certificate for registration of transfer at the offices or agencies maintained by the Trustee in its capacity as Registrar, or by any successor Registrar, duly endorsed or accompanied by a written instrument of transfer in form satisfactory to the Trustee and the Registrar, duly executed by the Certificateholder hereof or such Certificateholder's attorney duly authorized in writing, and thereupon one or more new Certificates of authorized denominations evidencing the same aggregate Fractional Undivided Interest in the Trust will be issued to the designated transferee or transferees.

The Certificates are issuable only as registered Certificates without coupons in minimum denominations of \$100,000 Fractional Undivided Interest and integral multiples of \$1,000 in excess thereof, except that one Certificate may be issued in a different denomination. As provided in the Agreement and subject to certain limitations therein set forth, the Certificates are exchangeable for new Certificates of authorized denominations evidencing the same aggregate Fractional Undivided Interest in the Trust, as requested by the Certificateholder surrendering the same.

No service charge will be made for any such registration of transfer or exchange, but the Trustee shall require payment of a sum sufficient to cover any tax or governmental charge payable in connection therewith.

Each Certificateholder and Investor, by its acceptance of this Certificate or a beneficial interest herein, agrees to treat the Trust as a grantor trust for all U.S. federal, state and local income tax purposes.

The Trustee, the Registrar, and any agent of the Trustee or the Registrar may treat the person in whose name this Certificate is registered as the owner hereof for all purposes, and neither the Trustee, the Registrar, nor any such agent shall be affected by any notice to the contrary.

The obligations and responsibilities created by the Agreement and the Trust created thereby shall terminate upon the distribution to Certificateholders of all amounts required to be distributed to them pursuant to the Agreement and the disposition of all property held as part of the Trust Property.

Any Person acquiring or accepting this Certificate or an interest herein will, by such acquisition or acceptance, be deemed to have represented and warranted to and for the benefit of the Company that either: (i) no assets of an employee benefit plan subject to Title I of the Employee Retirement Income Security Act of 1974, as amended ("ERISA"), a plan subject to Section 4975 of the Internal Revenue Code of 1986, as amended (the "Code"), or a governmental, church or foreign plan subject to a law that is similar to Title I of ERISA or Section 4975 of the Code (a "Similar Law Plan") have been used to purchase or hold this Certificate or an interest herein or (ii) the purchase and holding of this Certificate or an interest herein either (a) in the case of assets of an employee benefit plan subject to Title I of ERISA or a plan subject to Section 4975 of the Code, are exempt from the prohibited transaction restrictions of ERISA and the Code pursuant to one or more prohibited transaction statutory or administrative exemptions or (b) in the case of assets of a Similar Law Plan, will not violate any similar state, local or foreign law.

If the purchaser or transferee of this Certificate or an interest herein is an employee benefit plan subject to Title I of ERISA or a plan subject to Section 4975 of the Code, it will be deemed to represent, warrant and agree that (i) neither the Company nor any of its affiliates (or its or their agents) has provided any investment recommendation or investment advice on which it, or any fiduciary or other person investing the assets of such plan ("Plan Fiduciary"), has relied in connection with its decision to invest in this Certificate, and they are not otherwise acting as a fiduciary, as defined in Section 3(21) of ERISA or Section 4975(e)(3) of the Code, to such plan or the Plan Fiduciary in connection with such plan's acquisition of this Certificate; and (ii) the Plan Fiduciary is exercising its own independent judgment in evaluating the transaction.

THIS CERTIFICATE SHALL BE GOVERNED AND CONSTRUED IN ACCORDANCE WITH THE LAWS OF THE STATE OF NEW YORK AND THE OBLIGATIONS, RIGHTS AND REMEDIES OF THE PARTIES HEREUNDER SHALL BE DETERMINED IN ACCORDANCE WITH SUCH LAWS.

Unless the certificate of authentication hereon has been executed by the Trustee, by manual signature, this Certificate shall not be entitled to any benefit under the Agreement or be valid for any purpose.

IN WITNESS WHEREOF, the Trustee has caused this Certificate to be duly executed.

SUN COUNTRY PASS THROUGH TRUST 2019-1A

By: WILMINGTON TRUST, NATIONAL  
ASSOCIATION,  
as Trustee

By: \_\_\_\_\_  
Name:  
Title:

FORM OF THE TRUSTEE'S CERTIFICATE OF AUTHENTICATION

This is one of the Certificates referred to in the within-mentioned Agreement.

WILMINGTON TRUST, NATIONAL ASSOCIATION,  
as Trustee

By: \_\_\_\_\_

Name:

Title:



TRANSFER NOTICE

FORM OF TRANSFER NOTICE

FOR VALUE RECEIVED the undersigned registered holder (the "Transferor") hereby sell(s), assign(s) and transfer(s) unto

\_\_\_\_\_ (the "Transferee").

(Please print or typewrite name and address including zip code of assignee)

\_\_\_\_\_  
(Insert Taxpayer Identification No. of assignee)

the within Certificate and all rights thereunder, hereby irrevocably constituting and appointing

attorney to transfer said Certificate on the books of the Registrar with full power of substitution in the premises (the "Transfer").

[THE FOLLOWING PROVISION TO BE INCLUDED

ON ALL CERTIFICATES]

In connection with any transfer of this Certificate, the undersigned confirms that without utilizing any general solicitation or general advertising that:

PART A [check either Item 1 or Item 2 of this Part A]

Item 1. **Check if Transferor is a United States Person.** The Transferor hereby certifies that the Transfer is being made to another United States Person.

Item 2. **Check if Transferor is not a United States Person.**

As used in this Part A, "United States Person" has the meaning given to such term in the Internal Revenue Code of 1986, as amended.

PART B

(a) this Certificate is being transferred to an institution that is an "Accredited Investor" as defined in Rule 501(a)(1), (2), (3) or (7) of Regulation D under the Securities Act in a transaction exempt from the registration requirements of the Securities Act.

(b) this Certificate is being transferred to a "qualified institutional buyer" within the meaning of Rule 144A under the Securities Act and in compliance with the exemption from registration under the Securities Act provided by Rule 144A thereunder.

(c) this Certificate is being transferred in an offshore transaction meeting the requirements of Rule 903 or Rule 904 of Regulation S under the Securities Act.

(d) this Certificate is being transferred pursuant to an effective registration statement under the Securities Act.

(e) this Certificate is being transferred to Sun Country, Inc.

(f) the Certificate is being transferred other than in accordance with (a), (b), (c), (d) or (e) above in compliance with an exemption from registration under the Securities Act and documents are being furnished that comply with the conditions of transfer set forth in this Certificate and the Agreement.

If none of the foregoing boxes is checked, the Registrar shall not be obligated to register this Certificate in the name of any Person other than the Holder hereof unless and until the conditions to any such transfer of registration set forth herein and in Section 3.05 of the Trust Supplement shall have been satisfied.

Date:[\_\_\_\_\_, \_\_\_\_]

\_\_\_\_\_  
[Name of Transferor]

NOTE: The signature must correspond with the name as written upon the face of the within-mentioned instrument in every particular, without alteration or any change whatsoever.

Signature Guarantee: \_\_\_\_\_

TO BE COMPLETED BY TRANSFEREE IF (b) ABOVE IS CHECKED.

The undersigned represents and warrants that it is purchasing this Certificate for its own account or an account with respect to which it exercises sole investment discretion and that it and any Person on whose behalf it is acting with respect to any such account is a “qualified institutional buyer” within the meaning of Rule 144A under the Securities Act of 1933, as amended, and is aware that the sale to it is being made in reliance on Rule 144A and acknowledges that it has received such information regarding the Applicable Trust and/or the Company as the undersigned has requested pursuant to Rule 144A or has determined not to request such information and that it is aware that the transferor is relying upon the undersigned’s foregoing representations in order to claim the exemption from registration provided by Rule 144A.

Date:[\_\_\_\_\_, \_\_\_\_]

\_\_\_\_\_

## EXHIBIT A

## FORM OF CERTIFICATE

Certificate  
No. \_\_\_\_\_

PPN No: [   ]

SUN COUNTRY PASS THROUGH TRUST 2019-1B

Sun Country Pass Through Certificate, Series 2019-1B  
Issuance Date: [\_\_\_\_\_] , 2019

Final Legal Distribution Date: June 15, 2027

Evidencing A Fractional Undivided Interest In The Sun Country Pass Through Trust 2019-1B, The Property Of Which Shall Include Certain Equipment Notes Each Secured By An Aircraft Owned By Sun Country, Inc.

\$ [\_\_\_\_\_] Fractional Undivided Interest  
representing . [\_\_\_\_\_] % of the Trust per \$1,000 face amount

THIS CERTIFIES THAT \_\_\_\_\_, for value received, is the registered owner of a \$ \_\_\_\_\_ (\_\_\_\_\_ DOLLARS) Fractional Undivided Interest in the Sun Country Pass Through Trust 2019-1B (the "Trust") created by Wilmington Trust, National Association, as trustee (the "Trustee"), pursuant to a Pass Through Trust Agreement, dated as of December 9, 2019 (the "Basic Agreement"), between the Trustee and Sun Country, Inc., a Minnesota corporation (the "Company"), as supplemented by Trust Supplement No. 2019-1B thereto, dated as of December 9, 2019 (the "Trust Supplement" and, together with the Basic Agreement, the "Agreement"), between the Trustee and the Company, a summary of certain of the pertinent provisions of which is set forth below. To the extent not otherwise defined herein, the capitalized terms used herein have the meanings assigned to them in the Agreement. This Certificate is one of the duly authorized Certificates designated as "Sun Country Pass Through Certificates, Series 2019-1B" (herein called the "Certificates"). This Certificate is issued under and is subject to the terms, provisions and conditions of the Agreement. By virtue of its acceptance hereof, the holder of this Certificate (the "Certificateholder" and, together with all other holders of Certificates issued by the Trust, the "Certificateholders") assents to and agrees to be bound by the provisions of the Agreement and the Intercreditor Agreement. The property of the Trust includes certain Equipment Notes, and all rights of the Trust to receive payments under the Intercreditor Agreement (the "Trust Property"). Each issue of the Equipment Notes is secured by, among other things, a security interest in an Aircraft owned by the Company.

[AS OF THE DATE OF ISSUANCE OF THIS CERTIFICATE AND THROUGH THE OCCURRENCE OF THE FINAL PREFUNDING EXPIRY DATE (AND

DISTRIBUTION OF ANY AMOUNTS IN RELATION THERETO PURSUANT TO THE CERTIFICATE PURCHASE AGREEMENT), THE FACE AMOUNT AND FRACTIONAL UNDIVIDED INTEREST SET FORTH ABOVE IN THIS CERTIFICATE REMAIN SUBJECT TO ADJUSTMENT PURSUANT TO, AND THIS CERTIFICATE IS SUBJECT TO THE ADDITIONAL RESTRICTIONS ON TRANSFER SET FORTH IN, SECTION 3.07 OF THE TRUST SUPPLEMENT. THE ACTUAL FACE AMOUNT AND FRACTIONAL UNDIVIDED INTEREST REPRESENTED BY THIS CERTIFICATE, TAKING INTO ACCOUNT ANY SUCH ADJUSTMENTS, SHALL BE AS SET FORTH IN THE RECORDS MAINTAINED BY THE TRUSTEE PURSUANT TO SECTION 3.07 OF THE TRUST SUPPLEMENT.]<sup>1</sup>

The Certificates represent Fractional Undivided Interests in the Trust and the Trust Property and have no rights, benefits or interest in respect of any other separate trust established pursuant to the terms of the Basic Agreement for any other series of certificates issued pursuant thereto.

Subject to and in accordance with the terms of the Agreement and the Intercreditor Agreement, from funds then available to the Trustee, there will be distributed on June 15 and December 15 of each year (a "Regular Distribution Date") commencing June 15, 2020, to the Person in whose name this Certificate is registered at the close of business on the 15th day preceding the Regular Distribution Date, an amount in respect of the Scheduled Payments on the Equipment Notes due on such Regular Distribution Date, the receipt of which has been confirmed by the Trustee, equal to the product of the percentage interest in the Trust evidenced by this Certificate and an amount equal to the sum of such Scheduled Payments. Subject to and in accordance with the terms of the Agreement and the Intercreditor Agreement, in the event that Special Payments on the Equipment Notes are received by the Trustee, from funds then available to the Trustee, there shall be distributed on the applicable Special Distribution Date, to the Person in whose name this Certificate is registered at the close of business on the 15th day preceding the Special Distribution Date, an amount in respect of such Special Payments on the Equipment Notes, the receipt of which has been confirmed by the Trustee, equal to the product of the percentage interest in the Trust evidenced by this Certificate and an amount equal to the sum of such Special Payments so received. If a Regular Distribution Date or Special Distribution Date is not a Business Day, distribution shall be made on the immediately following Business Day with the same force and effect as if made on such Regular Distribution Date or Special Distribution Date and no interest shall accrue during the intervening period. The Trustee shall mail notice of each Special Payment and the Special Distribution Date therefor to the Certificateholder of this Certificate.

Distributions on this Certificate will be made by the Trustee by check mailed to the Person entitled thereto, without presentation or surrender of this Certificate or the making of any notation hereon. Except as otherwise provided in the Agreement and notwithstanding the

---

<sup>1</sup> This Section 3.07 Paragraph should be included in each Applicable Certificate issued prior to the Final Prefunding Expiry Date. This 3.07 Paragraph should be omitted from Applicable Certificates issued after the Final Prefunding Expiry Date (each of which should each be issued in the applicable face amounts and reflecting Fractional Undivided Interests after taking into account all applicable adjustments pursuant to Section 3.07 of the Trust Supplement).

above, the final distribution on this Certificate will be made after notice mailed by the Trustee of the pendency of such distribution and only upon presentation and surrender of this Certificate at the office or agency of the Trustee specified in such notice.

The Certificates do not represent a direct obligation of, or an obligation guaranteed by, or an interest in, the Company or the Trustee or any affiliate thereof. The Certificates are limited in right of payment, all as more specifically set forth on the face hereof and in the Agreement. All payments or distributions made to Certificateholders under the Agreement shall be made only from the Trust Property and only to the extent that the Trustee shall have sufficient income or proceeds from the Trust Property to make such payments in accordance with the terms of the Agreement. Each Certificateholder of this Certificate, by its acceptance hereof, agrees that it will look solely to the income and proceeds from the Trust Property to the extent available for distribution to such Certificateholder as provided in the Agreement. This Certificate does not purport to summarize the Agreement and reference is made to the Agreement for information with respect to the interests, rights, benefits, obligations, privileges, and duties evidenced hereby. A copy of the Agreement may be examined during normal business hours at the principal office of the Trustee, and at such other places, if any, designated by the Trustee, by any Certificateholder upon request.

The Agreement permits, with certain exceptions therein provided, the amendment thereof and the modification of the rights and obligations of the Company and the rights of the Certificateholders under the Agreement at any time by the Company and the Trustee with the consent of the Certificateholders holding Certificates evidencing Fractional Undivided Interests aggregating not less than a majority in interest in the Trust. Any such consent by the Certificateholder of this Certificate shall be conclusive and binding on such Certificateholder and upon all future Certificateholders of this Certificate and of any Certificate issued upon the transfer hereof or in exchange hereof or in lieu hereof whether or not notation of such consent is made upon this Certificate. The Agreement also permits the amendment thereof, in certain limited circumstances, without the consent of the Certificateholders of any of the Certificates.

As provided in the Agreement and subject to certain limitations set forth therein, the transfer of this Certificate is registrable in the Register upon surrender of this Certificate for registration of transfer at the offices or agencies maintained by the Trustee in its capacity as Registrar, or by any successor Registrar, duly endorsed or accompanied by a written instrument of transfer in form satisfactory to the Trustee and the Registrar, duly executed by the Certificateholder hereof or such Certificateholder's attorney duly authorized in writing, and thereupon one or more new Certificates of authorized denominations evidencing the same aggregate Fractional Undivided Interest in the Trust will be issued to the designated transferee or transferees.

The Certificates are issuable only as registered Certificates without coupons in minimum denominations of \$100,000 Fractional Undivided Interest and integral multiples of \$1,000 in excess thereof, except that one Certificate may be issued in a different denomination. As provided in the Agreement and subject to certain limitations therein set forth, the Certificates are exchangeable for new Certificates of authorized denominations evidencing the same aggregate Fractional Undivided Interest in the Trust, as requested by the Certificateholder surrendering the same.

No service charge will be made for any such registration of transfer or exchange, but the Trustee shall require payment of a sum sufficient to cover any tax or governmental charge payable in connection therewith.

Each Certificateholder and Investor, by its acceptance of this Certificate or a beneficial interest herein, agrees to treat the Trust as a grantor trust for all U.S. federal, state and local income tax purposes.

The Trustee, the Registrar, and any agent of the Trustee or the Registrar may treat the person in whose name this Certificate is registered as the owner hereof for all purposes, and neither the Trustee, the Registrar, nor any such agent shall be affected by any notice to the contrary.

The obligations and responsibilities created by the Agreement and the Trust created thereby shall terminate upon the distribution to Certificateholders of all amounts required to be distributed to them pursuant to the Agreement and the disposition of all property held as part of the Trust Property.

Any Person acquiring or accepting this Certificate or an interest herein will, by such acquisition or acceptance, be deemed to have represented and warranted to and for the benefit of the Company that either: (i) no assets of an employee benefit plan subject to Title I of the Employee Retirement Income Security Act of 1974, as amended ("ERISA"), a plan subject to Section 4975 of the Internal Revenue Code of 1986, as amended (the "Code"), or a governmental, church or foreign plan subject to a law that is similar to Title I of ERISA or Section 4975 of the Code (a "Similar Law Plan") have been used to purchase or hold this Certificate or an interest herein or (ii) the purchase and holding of this Certificate or an interest herein either (a) in the case of assets of an employee benefit plan subject to Title I of ERISA or a plan subject to Section 4975 of the Code, are exempt from the prohibited transaction restrictions of ERISA and the Code pursuant to one or more prohibited transaction statutory or administrative exemptions or (b) in the case of assets of a Similar Law Plan, will not violate any similar state, local or foreign law.

If the purchaser or transferee of this Certificate or an interest herein is an employee benefit plan subject to Title I of ERISA or a plan subject to Section 4975 of the Code, it will be deemed to represent, warrant and agree that (i) neither the Company nor any of its affiliates (or its or their agents) has provided any investment recommendation or investment advice on which it, or any fiduciary or other person investing the assets of such plan ("Plan Fiduciary"), has relied in connection with its decision to invest in this Certificate, and they are not otherwise acting as a fiduciary, as defined in Section 3(21) of ERISA or Section 4975(e)(3) of the Code, to such plan or the Plan Fiduciary in connection with such plan's acquisition of this Certificate; and (ii) the Plan Fiduciary is exercising its own independent judgment in evaluating the transaction.

THIS CERTIFICATE SHALL BE GOVERNED AND CONSTRUED IN ACCORDANCE WITH THE LAWS OF THE STATE OF NEW YORK AND THE OBLIGATIONS, RIGHTS AND REMEDIES OF THE PARTIES HEREUNDER SHALL BE DETERMINED IN ACCORDANCE WITH SUCH LAWS.

Unless the certificate of authentication hereon has been executed by the Trustee, by manual signature, this Certificate shall not be entitled to any benefit under the Agreement or be valid for any purpose.

IN WITNESS WHEREOF, the Trustee has caused this Certificate to be duly executed.

SUN COUNTRY PASS THROUGH TRUST 2019-1B

By: WILMINGTON TRUST, NATIONAL  
ASSOCIATION,  
as Trustee

By: \_\_\_\_\_  
Name:  
Title:



FORM OF THE TRUSTEE'S CERTIFICATE OF AUTHENTICATION

This is one of the Certificates referred to in the within-mentioned Agreement.

WILMINGTON TRUST, NATIONAL ASSOCIATION,  
as Trustee

By: \_\_\_\_\_

Name:

Title:

TRANSFER NOTICE

FORM OF TRANSFER NOTICE

FOR VALUE RECEIVED the undersigned registered holder (the "Transferor") hereby sell(s), assign(s) and transfer(s) unto

\_\_\_\_\_ (the "Transferee").

(Please print or typewrite name and address including zip code of assignee)

\_\_\_\_\_  
(Insert Taxpayer Identification No. of assignee)

the within Certificate and all rights thereunder, hereby irrevocably constituting and appointing

attorney to transfer said Certificate on the books of the Registrar with full power of substitution in the premises (the "Transfer").

[THE FOLLOWING PROVISION TO BE INCLUDED

ON ALL CERTIFICATES]

In connection with any transfer of this Certificate, the undersigned confirms that without utilizing any general solicitation or general advertising that:

PART A [check either Item 1 or Item 2 of this Part A]

Item 1. **Check if Transferor is a United States Person.** The Transferor hereby certifies that the Transfer is being made to another United States Person.

Item 2. **Check if Transferor is not a United States Person.**

As used in this Part A, "United States Person" has the meaning given to such term in the Internal Revenue Code of 1986, as amended.

PART B

(a) this Certificate is being transferred to an institution that is an "Accredited Investor" as defined in Rule 501(a)(1), (2), (3) or (7) of Regulation D under the Securities Act in a transaction exempt from the registration requirements of the Securities Act.

(b) this Certificate is being transferred to a "qualified institutional buyer" within the meaning of Rule 144A under the Securities Act and in compliance with the exemption from registration under the Securities Act provided by Rule 144A thereunder.

(c) this Certificate is being transferred in an offshore transaction meeting the requirements of Rule 903 or Rule 904 of Regulation S under the Securities Act.

(d) this Certificate is being transferred pursuant to an effective registration statement under the Securities Act.

(e) this Certificate is being transferred to Sun Country, Inc.

(f) the Certificate is being transferred other than in accordance with (a), (b), (c), (d) or (e) above in compliance with an exemption from registration under the Securities Act and documents are being furnished that comply with the conditions of transfer set forth in this Certificate and the Agreement.

If none of the foregoing boxes is checked, the Registrar shall not be obligated to register this Certificate in the name of any Person other than the Holder hereof unless and until the conditions to any such transfer of registration set forth herein and in Section 3.05 of the Trust Supplement shall have been satisfied.

Date:[\_\_\_\_\_, \_\_\_\_]

\_\_\_\_\_  
[Name of Transferor]

NOTE: The signature must correspond with the name as written upon the face of the within-mentioned instrument in every particular, without alteration or any change whatsoever.

Signature Guarantee: \_\_\_\_\_

TO BE COMPLETED BY TRANSFEREE IF (b) ABOVE IS CHECKED.

The undersigned represents and warrants that it is purchasing this Certificate for its own account or an account with respect to which it exercises sole investment discretion and that it and any Person on whose behalf it is acting with respect to any such account is a “qualified institutional buyer” within the meaning of Rule 144A under the Securities Act of 1933, as amended, and is aware that the sale to it is being made in reliance on Rule 144A and acknowledges that it has received such information regarding the Applicable Trust and/or the Company as the undersigned has requested pursuant to Rule 144A or has determined not to request such information and that it is aware that the transferor is relying upon the undersigned’s foregoing representations in order to claim the exemption from registration provided by Rule 144A.

Date:[\_\_\_\_\_, \_\_\_\_]

\_\_\_\_\_

## EXHIBIT A

## FORM OF CERTIFICATE

Certificate  
No. \_\_\_\_

PPN No: [ ]

SUN COUNTRY PASS THROUGH TRUST 2019-1C

Sun Country Pass Through Certificate, Series 2019-1C  
Issuance Date: [ ], 2019

Final Legal Distribution Date: [December 15, 2023]

Evidencing A Fractional Undivided Interest In The Sun Country Pass Through Trust 2019-1C, The Property Of Which Shall Include Certain Equipment Notes Each Secured By An Aircraft Owned By Sun Country, Inc.

\$[ ] Fractional Undivided Interest  
representing .[ ]% of the Trust per \$1,000 face amount

THIS CERTIFIES THAT \_\_\_\_\_, for value received, is the registered owner of a \$ \_\_\_\_\_ ( \_\_\_\_\_ DOLLARS) Fractional Undivided Interest in the Sun Country Pass Through Trust 2019-1A (the "Trust") created by Wilmington Trust, National Association, as trustee (the "Trustee"), pursuant to a Pass Through Trust Agreement, dated as of December 9, 2019 (the "Basic Agreement"), between the Trustee and Sun Country, Inc., a Minnesota corporation (the "Company"), as supplemented by Trust Supplement No. 2019-1C thereto, dated as of December 9, 2019 (the "Trust Supplement" and, together with the Basic Agreement, the "Agreement"), between the Trustee and the Company, a summary of certain of the pertinent provisions of which is set forth below. To the extent not otherwise defined herein, the capitalized terms used herein have the meanings assigned to them in the Agreement. This Certificate is one of the duly authorized Certificates designated as "Sun Country Pass Through Certificates, Series 2019-1C" (herein called the "Certificates"). This Certificate is issued under and is subject to the terms, provisions and conditions of the Agreement. By virtue of its acceptance hereof, the holder of this Certificate (the "Certificateholder" and, together with all other holders of Certificates issued by the Trust, the "Certificateholders") assents to and agrees to be bound by the provisions of the Agreement and the Intercreditor Agreement. The property of the Trust includes certain Equipment Notes, and all rights of the Trust to receive payments under the Intercreditor Agreement (the "Trust Property"). Each issue of the Equipment Notes is secured by, among other things, a security interest in an Aircraft owned by the Company.

The Certificates represent Fractional Undivided Interests in the Trust and the Trust Property and have no rights, benefits or interest in respect of any other separate trust established pursuant to the terms of the Basic Agreement for any other series of certificates issued pursuant thereto.

Subject to and in accordance with the terms of the Agreement and the Intercreditor Agreement, from funds then available to the Trustee, there will be distributed on June 15 and December 15 of each year (a "Regular Distribution Date") commencing June 15, 2020, to the Person in whose name this Certificate is registered at the close of business on the 15th day preceding the Regular Distribution Date, an amount in respect of the Scheduled Payments on the Equipment Notes due on such Regular Distribution Date, the receipt of which has been confirmed by the Trustee, equal to the product of the percentage interest in the Trust evidenced by this Certificate and an amount equal to the sum of such Scheduled Payments. Subject to and in accordance with the terms of the Agreement and the Intercreditor Agreement, in the event that Special Payments on the Equipment Notes are received by the Trustee, from funds then available to the Trustee, there shall be distributed on the applicable Special Distribution Date, to the Person in whose name this Certificate is registered at the close of business on the 15th day preceding the Special Distribution Date, an amount in respect of such Special Payments on the Equipment Notes, the receipt of which has been confirmed by the Trustee, equal to the product of the percentage interest in the Trust evidenced by this Certificate and an amount equal to the sum of such Special Payments so received. If a Regular Distribution Date or Special Distribution Date is not a Business Day, distribution shall be made on the immediately following Business Day with the same force and effect as if made on such Regular Distribution Date or Special Distribution Date and no interest shall accrue during the intervening period. The Trustee shall mail notice of each Special Payment and the Special Distribution Date therefor to the Certificateholder of this Certificate.

Distributions on this Certificate will be made by the Trustee by check mailed to the Person entitled thereto, without presentation or surrender of this Certificate or the making of any notation hereon. Except as otherwise provided in the Agreement and notwithstanding the above, the final distribution on this Certificate will be made after notice mailed by the Trustee of the pendency of such distribution and only upon presentation and surrender of this Certificate at the office or agency of the Trustee specified in such notice.

The Certificates do not represent a direct obligation of, or an obligation guaranteed by, or an interest in, the Company or the Trustee or any affiliate thereof. The Certificates are limited in right of payment, all as more specifically set forth on the face hereof and in the Agreement. All payments or distributions made to Certificateholders under the Agreement shall be made only from the Trust Property and only to the extent that the Trustee shall have sufficient income or proceeds from the Trust Property to make such payments in accordance with the terms of the Agreement. Each Certificateholder of this Certificate, by its acceptance hereof, agrees that it will look solely to the income and proceeds from the Trust Property to the extent available for distribution to such Certificateholder as provided in the Agreement. This Certificate does not purport to summarize the Agreement and reference is made to the Agreement for information with respect to the interests, rights, benefits, obligations, privileges, and duties evidenced hereby. A copy of the Agreement may be examined during normal business hours at the principal office of the Trustee, and at such other places, if any, designated by the Trustee, by any Certificateholder upon request.

The Agreement permits, with certain exceptions therein provided, the amendment thereof and the modification of the rights and obligations of the Company and the rights of the Certificateholders under the Agreement at any time by the Company and the Trustee with the consent of the Certificateholders holding Certificates evidencing Fractional Undivided Interests aggregating not less than a majority in interest in the Trust. Any such consent by the Certificateholder of this Certificate shall be conclusive and binding on such Certificateholder and upon all future Certificateholders of this Certificate and of any Certificate issued upon the transfer hereof or in exchange hereof or in lieu hereof whether or not notation of such consent is made upon this Certificate. The Agreement also permits the amendment thereof, in certain limited circumstances, without the consent of the Certificateholders of any of the Certificates.

As provided in the Agreement and subject to certain limitations set forth therein, the transfer of this Certificate is registrable in the Register upon surrender of this Certificate for registration of transfer at the offices or agencies maintained by the Trustee in its capacity as Registrar, or by any successor Registrar, duly endorsed or accompanied by a written instrument of transfer in form satisfactory to the Trustee and the Registrar, duly executed by the Certificateholder hereof or such Certificateholder's attorney duly authorized in writing, and thereupon one or more new Certificates of authorized denominations evidencing the same aggregate Fractional Undivided Interest in the Trust will be issued to the designated transferee or transferees.

The Certificates are issuable only as registered Certificates without coupons in minimum denominations of \$100,000 Fractional Undivided Interest and integral multiples of \$1,000 in excess thereof, except that one Certificate may be issued in a different denomination. As provided in the Agreement and subject to certain limitations therein set forth, the Certificates are exchangeable for new Certificates of authorized denominations evidencing the same aggregate Fractional Undivided Interest in the Trust, as requested by the Certificateholder surrendering the same.

No service charge will be made for any such registration of transfer or exchange, but the Trustee shall require payment of a sum sufficient to cover any tax or governmental charge payable in connection therewith.

Each Certificateholder and Investor, by its acceptance of this Certificate or a beneficial interest herein, agrees to treat the Trust as a grantor trust for all U.S. federal, state and local income tax purposes.

The Trustee, the Registrar, and any agent of the Trustee or the Registrar may treat the person in whose name this Certificate is registered as the owner hereof for all purposes, and neither the Trustee, the Registrar, nor any such agent shall be affected by any notice to the contrary.

The obligations and responsibilities created by the Agreement and the Trust created thereby shall terminate upon the distribution to Certificateholders of all amounts required to be distributed to them pursuant to the Agreement and the disposition of all property held as part of the Trust Property.

Any Person acquiring or accepting this Certificate or an interest herein will, by such acquisition or acceptance, be deemed to have represented and warranted to and for the benefit of the Company that either: (i) no assets of an employee benefit plan subject to Title I of the Employee Retirement Income Security Act of 1974, as amended ("ERISA"), a plan subject to Section 4975 of the Internal Revenue Code of 1986, as amended (the "Code"), or a governmental, church or foreign plan subject to a law that is similar to Title I of ERISA or Section 4975 of the Code (a "Similar Law Plan") have been used to purchase or hold this Certificate or an interest herein or (ii) the purchase and holding of this Certificate or an interest herein either (a) in the case of assets of an employee benefit plan subject to Title I of ERISA or a plan subject to Section 4975 of the Code, are exempt from the prohibited transaction restrictions of ERISA and the Code pursuant to one or more prohibited transaction statutory or administrative exemptions or (b) in the case of assets of a Similar Law Plan, will not violate any similar state, local or foreign law.

If the purchaser or transferee of this Certificate or an interest herein is an employee benefit plan subject to Title I of ERISA or a plan subject to Section 4975 of the Code, it will be deemed to represent, warrant and agree that (i) neither the Company nor any of its affiliates (or its or their agents) has provided any investment recommendation or investment advice on which it, or any fiduciary or other person investing the assets of such plan ("Plan Fiduciary"), has relied in connection with its decision to invest in this Certificate, and they are not otherwise acting as a fiduciary, as defined in Section 3(21) of ERISA or Section 4975(e)(3) of the Code, to such plan or the Plan Fiduciary in connection with such plan's acquisition of this Certificate; and (ii) the Plan Fiduciary is exercising its own independent judgment in evaluating the transaction.

THIS CERTIFICATE SHALL BE GOVERNED AND CONSTRUED IN ACCORDANCE WITH THE LAWS OF THE STATE OF NEW YORK AND THE OBLIGATIONS, RIGHTS AND REMEDIES OF THE PARTIES HEREUNDER SHALL BE DETERMINED IN ACCORDANCE WITH SUCH LAWS.

Unless the certificate of authentication hereon has been executed by the Trustee, by manual signature, this Certificate shall not be entitled to any benefit under the Agreement or be valid for any purpose.

IN WITNESS WHEREOF, the Trustee has caused this Certificate to be duly executed.

SUN COUNTRY PASS THROUGH TRUST 2019-1C

By: WILMINGTON TRUST, NATIONAL  
ASSOCIATION,  
as Trustee

By: \_\_\_\_\_  
Name:  
Title:



FORM OF THE TRUSTEE'S CERTIFICATE OF AUTHENTICATION

This is one of the Certificates referred to in the within-mentioned Agreement.

WILMINGTON TRUST, NATIONAL ASSOCIATION,  
as Trustee

By: \_\_\_\_\_

Name:

Title:

TRANSFER NOTICE

FORM OF TRANSFER NOTICE

FOR VALUE RECEIVED the undersigned registered holder (the "Transferor") hereby sell(s), assign(s) and transfer(s) unto

(the "Transferee")

---

(Please print or typewrite name and address including zip code of assignee)

---

(Insert Taxpayer Identification No. of assignee)

the within Certificate and all rights thereunder, hereby irrevocably constituting and appointing

attorney to transfer said Certificate on the books of the Registrar with full power of substitution in the premises (the "Transfer").

[THE FOLLOWING PROVISION TO BE INCLUDED

ON ALL CERTIFICATES]

In connection with any transfer of this Certificate, the undersigned confirms that without utilizing any general solicitation or general advertising that:

PART A [check either Item 1 or Item 2 of this Part A]

Item 1. **Check if Transferor is a United States Person.** The Transferor hereby certifies that the Transfer is being made to another United States Person.

Item 2. **Check if Transferor is not a United States Person.**

As used in this Part A, "United States Person" has the meaning given to such term in the Internal Revenue Code of 1986, as amended.

PART B

(a) this Certificate is being transferred to an institution that is an "Accredited Investor" as defined in Rule 501(a)(1), (2), (3) or (7) of Regulation D under the Securities Act in a transaction exempt from the registration requirements of the Securities Act.

(b) this Certificate is being transferred to a "qualified institutional buyer" within the meaning of Rule 144A under the Securities Act and in compliance with the exemption from registration under the Securities Act provided by Rule 144A thereunder.

If neither of the foregoing boxes is checked, the Registrar shall not be obligated to register this Certificate in the name of any Person other than the Holder hereof unless and until the conditions to any such transfer of registration set forth herein and in Section 3.05 of the Trust Supplement shall have been satisfied.

Date: [\_\_\_\_\_, \_\_\_\_]

\_\_\_\_\_

[Name of Transferor]

NOTE: The signature must correspond with the name as written upon the face of the within-mentioned instrument in every particular, without alteration or any change whatsoever.

Signature Guarantee: \_\_\_\_\_

TO BE COMPLETED BY TRANSFEREE IF (b) ABOVE IS CHECKED.

The undersigned represents and warrants that it is purchasing this Certificate for its own account or an account with respect to which it exercises sole investment discretion and that it and any Person on whose behalf it is acting with respect to any such account is a "qualified institutional buyer" within the meaning of Rule 144A under the Securities Act of 1933, as amended, and is aware that the sale to it is being made in reliance on Rule 144A and acknowledges that it has received such information regarding the Applicable Trust and/or the Company as the undersigned has requested pursuant to Rule 144A or has determined not to request such information and that it is aware that the transferor is relying upon the undersigned's foregoing representations in order to claim the exemption from registration provided by Rule 144A.

Date: [\_\_\_\_\_, \_\_\_\_]

\_\_\_\_\_

INTERCREDITOR AGREEMENT  
(2019-1)

Dated as of  
December 9, 2019

AMONG

WILMINGTON TRUST, NATIONAL ASSOCIATION,  
not in its individual capacity  
but solely as Trustee under the  
Sun Country Pass Through Trust 2019-1A,  
Sun Country Pass Through Trust 2019-1B, and  
Sun Country Pass Through Trust 2019-1C,

AND

WILMINGTON TRUST, NATIONAL ASSOCIATION,  
not in its individual capacity except  
as expressly set forth herein but  
solely as Subordination Agent and Trustee

TABLE OF CONTENTS

	<u>Page</u>
ARTICLE I DEFINITIONS	1
SECTION 1.1. Definitions	1
ARTICLE II TRUST ACCOUNTS; CONTROLLING PARTY	16
SECTION 2.1. Agreement to Terms of Subordination; Payments from Monies Received Only	16
SECTION 2.2. Trust Accounts	17
SECTION 2.3. Deposits to the Collection Account and Special Payments Account	18
SECTION 2.4. Distributions of Special Payments	18
SECTION 2.5. Designated Representatives	19
SECTION 2.6. Controlling Party	20
ARTICLE III RECEIPT, DISTRIBUTION AND APPLICATION OF AMOUNTS RECEIVED	21
SECTION 3.1. Written Notice of Distribution	21
SECTION 3.2. Distribution of Amounts on Deposit in the Collection Account	22
SECTION 3.3. Other Payments	24
SECTION 3.4. Payments to the Trustees	24
SECTION 3.5. [Reserved]	24
ARTICLE IV EXERCISE OF REMEDIES	24
SECTION 4.1. Directions from the Controlling Party	24
SECTION 4.2. Remedies Cumulative	26
SECTION 4.3. Discontinuance of Proceedings	26
SECTION 4.4. Right of Certificateholders to Receive Payments Not to Be Impaired	26
SECTION 4.5. Undertaking for Costs	27
ARTICLE V DUTIES OF THE SUBORDINATION AGENT; AGREEMENTS OF TRUSTEES, ETC.	27
SECTION 5.1. Notice of Indenture Default or Triggering Event	27
SECTION 5.2. Indemnification	28
SECTION 5.3. No Duties Except as Specified in this Intercreditor Agreement	29
SECTION 5.4. Notice from the Trustees	29
ARTICLE VI THE SUBORDINATION AGENT	29
SECTION 6.1. Authorization; Acceptance of Trusts and Duties	29
SECTION 6.2. Absence of Duties	29
SECTION 6.3. No Representations or Warranties as to Documents	29
SECTION 6.4. No Segregation of Monies; No Interest	30

	<u>Page</u>
SECTION 6.5. Reliance; Agents; Advice of Counsel	30
SECTION 6.6. Capacity in Which Acting	30
SECTION 6.7. Compensation	30
SECTION 6.8. May Become Certificateholder	30
SECTION 6.9. Subordination Agent Required; Eligibility	31
SECTION 6.10. Money to Be Held in Trust	31
SECTION 6.11. Notice of Substitution of Airframe	31
ARTICLE VII INDEMNIFICATION OF SUBORDINATION AGENT	31
SECTION 7.1. Scope of Indemnification	31
ARTICLE VIII SUCCESSOR SUBORDINATION AGENT	32
SECTION 8.1. Replacement of Subordination Agent; Appointment of Successor	32
ARTICLE IX SUPPLEMENTS AND AMENDMENTS	33
SECTION 9.1. Amendments, Waivers, Possible Future Issuance of an Additional Class of Certificates, etc.	33
SECTION 9.2. Subordination Agent Protected	36
SECTION 9.3. Effect of Supplemental Agreements	36
SECTION 9.4. Notice to Rating Agency	36
ARTICLE X MISCELLANEOUS	36
SECTION 10.1. Termination of Intercreditor Agreement	36
SECTION 10.2. Intercreditor Agreement for Benefit of Trustees and Subordination Agent	37
SECTION 10.3. Notices	37
SECTION 10.4. Severability	37
SECTION 10.5. No Oral Modifications or Continuing Waivers	37
SECTION 10.6. Successors and Assigns	38
SECTION 10.7. Headings	38
SECTION 10.8. Counterpart Form	38
SECTION 10.9. Subordination	38
SECTION 10.10. Governing Law	38
SECTION 10.11. Submission to Jurisdiction; Waiver of Jury Trial; Waiver of Immunity	39

## INTERCREDITOR AGREEMENT

INTERCREDITOR AGREEMENT (this "Agreement") dated as of December 9, 2019, among WILMINGTON TRUST, NATIONAL ASSOCIATION, a national banking association ("WTNA"), not in its individual capacity but solely as Trustee of each Trust (each as defined below); and WTNA, not in its individual capacity except as expressly set forth herein, but solely as Subordination Agent and trustee hereunder (in such capacity, together with any successor appointed pursuant to Article VIII hereof, the "Subordination Agent").

WHEREAS, all capitalized terms used herein shall have the respective meanings referred to in Article I hereof;

WHEREAS, pursuant to each Indenture, Sun Country will issue on a recourse basis three series of Equipment Notes to finance the related Aircraft;

WHEREAS, pursuant to the Financing Agreements, each Trust will acquire Equipment Notes having an interest rate equal to the Stated Interest Rate applicable to the Certificates to be issued by such Trust;

WHEREAS, pursuant to each Trust Agreement, the Trust created thereby proposes to issue a single class of Certificates (a "Class") having the interest rate and the final distribution date described in such Trust Agreement on the terms and subject to the conditions set forth therein;

WHEREAS, pursuant to the Certificate Purchase Agreement, the Purchasers propose to purchase the Class A Certificates issued by the Class A Trust, the Class B Certificates issued by the Class B Trust and the Class C Certificates issued by the Class C Trust in the aggregate face amount set forth opposite the name of such Trust on Schedule I thereto on the terms and subject to the conditions set forth therein; and

WHEREAS, it is a condition precedent to the obligations of the Purchasers under the Certificate Purchase Agreement that the Subordination Agent and the Trustees agree to the terms of subordination set forth in this Agreement in respect of each Class of Certificates, and the Subordination Agent and the Trustees, by entering into this Agreement, hereby acknowledge and agree to such terms of subordination and the other provisions of this Agreement.

NOW, THEREFORE, in consideration of the mutual agreements herein contained, and for other good and valuable consideration, the receipt and adequacy of which are hereby acknowledged, the parties hereto agree as follows:

### ARTICLE I

#### DEFINITIONS

SECTION 1.1. Definitions. For all purposes of this Agreement, except as otherwise expressly provided or unless the context otherwise requires:

(1) the terms used herein that are defined in this Article have the meanings assigned to them in this Article, and include the plural as well as the singular;

(2) all references in this Agreement to designated “Articles”, “Sections” and other subdivisions are to the designated Articles, Sections and other subdivisions of this Agreement;

(3) the words “herein”, “hereof” and “hereunder” and other words of similar import refer to this Agreement as a whole and not to any particular Article, Section or other subdivision; and

(4) the term “including” means “including without limitation”.

“Acceleration” means, with respect to the amounts payable in respect of the Equipment Notes issued under any Indenture, such amounts becoming immediately due and payable by declaration or otherwise. “Accelerate”, “Accelerated” and “Accelerating” have meanings correlative to the foregoing.

“Actual Disposition Event” means, in respect of any Equipment Note: (i) the disposition of the Aircraft securing such Equipment Note, (ii) the occurrence of the mandatory redemption date for such Equipment Note following an Event of Loss (as defined in such Indenture) with respect to the Aircraft which secured such Equipment Note or (iii) the sale of such Equipment Note.

“Additional Certificateholders” has the meaning specified in Section 9.1(d).

“Additional Certificates” has the meaning specified in Section 9.1(d).

“Additional Equipment Notes” has the meaning specified in Section 9.1(d).

“Additional Trust” has the meaning specified in Section 9.1(d).

“Additional Trust Agreement” has the meaning specified in Section 9.1(d).

“Additional Trustee” has the meaning specified in Section 9.1(d).

“Administration Expenses” has the meaning specified in clause “first” of Section 3.2.

“Affiliate” means, with respect to any Person, any other Person directly or indirectly controlling, controlled by or under common control with such Person. For the purposes of this definition, “control” means the power, directly or indirectly, to direct or cause the direction of the management and policies of such Person whether through the ownership of voting securities or by contract or otherwise; and the terms “controlling” and “controlled” have meanings correlative to the foregoing.

“Aircraft” means, with respect to each Indenture, the “Aircraft” referred to therein.



“Appraisal” has the meaning specified in Section 4.1(a)(iv).

“Appraised Current Market Value” of any Aircraft means the lower of the average and the median of the three most recent Post-Default Appraisals of such Aircraft.

“Appraisers” means Aircraft Information Services, Inc., BK Associates, Inc. and Morten Beyer and Agnew, Inc. or, so long as the Person entitled or required hereunder to select such Appraiser acts reasonably, any other nationally recognized appraiser reasonably satisfactory to the Subordination Agent and the Controlling Party.

“Bankruptcy Code” means the United States Bankruptcy Code, 11 U.S.C. Sections 101 *et seq.*

“Bankruptcy Event” means the occurrence and continuation of any of the following:

(a) Sun Country shall consent to the appointment of or the taking of possession by a receiver, trustee or liquidator of itself or of a substantial part of its property, or Sun Country shall admit in writing its inability to pay its debts generally as they come due, or does not pay its debts generally as they become due or shall make a general assignment for the benefit of creditors, or Sun Country shall file a voluntary petition in bankruptcy or a voluntary petition or an answer seeking reorganization, liquidation or other relief in a case under any bankruptcy laws or other insolvency laws (as in effect at such time) or an answer admitting the material allegations of a petition filed against Sun Country in any such case, or Sun Country shall seek relief by voluntary petition, answer or consent, under the provisions of any other bankruptcy or other similar law providing for the reorganization or winding-up of corporations (as in effect at such time) or Sun Country shall seek an agreement, composition, extension or adjustment with its creditors under such laws, or Sun Country’s board of directors shall adopt a resolution authorizing corporate action in furtherance of any of the foregoing; or

(b) an order, judgment or decree shall be entered by any court of competent jurisdiction appointing, without the consent of Sun Country, a receiver, trustee or liquidator of Sun Country or of any substantial part of its property, or any substantial part of the property of Sun Country shall be sequestered, or granting any other relief in respect of Sun Country as a debtor under any bankruptcy laws or other insolvency laws (as in effect at such time), and any such order, judgment or decree of appointment or sequestration shall remain in force undismissed, unstayed and unvacated for a period of 60 days after the date of entry thereof; or

(c) a petition against Sun Country in a case under any bankruptcy laws or other insolvency laws (as in effect at such time) is filed and not withdrawn or dismissed within 60 days thereafter, or if, under the provisions of any law providing for reorganization or winding-up of corporations which may apply to Sun Country, any court of competent jurisdiction assumes jurisdiction, custody or control of Sun Country or of any substantial part of its property and such jurisdiction, custody or control remains in force unrelinquished, unstayed and unterminated for a period of 60 days.

“Basic Agreement” means the Pass Through Trust Agreement dated as of December 9, 2019 between Sun Country and WTNA, not in its individual capacity, except as otherwise expressly provided therein, but solely as trustee.

“Business Day” means any day other than a Saturday or Sunday or a day on which commercial banks are required or authorized to close in Eagan, Minnesota, New York, New York, or, so long as any Certificate is outstanding, the city and state in which any Trustee, the Subordination Agent or any Loan Trustee maintains its Corporate Trust Office.

“Certificate” means a Class A Certificate, a Class B Certificate or Class C Certificate, as applicable.

“Certificate Purchase Agreement” means the Certificate Purchase Agreement dated December 9, 2019 among the Purchasers, each Trustee, WTNA and Sun Country, relating to the purchase of the Certificates by the Purchasers, as the same may be amended, supplemented or otherwise modified from time to time in accordance with its terms.

“Certificateholder” means any holder of one or more Certificates.

“Class” has the meaning assigned to such term in the preliminary statements to this Agreement.

“Class A Certificateholder” means, at any time, any holder of one or more Class A Certificates.

“Class A Certificates” means the certificates issued by the Class A Trust, substantially in the form of Exhibit A to the Class A Trust Agreement, and authenticated by the Class A Trustee, representing fractional undivided interests in the Class A Trust, and any certificates issued in exchange therefor or replacement thereof pursuant to the terms of the Class A Trust Agreement.

“Class A Trust” means the Sun Country Pass Through Trust 2019-1A created and administered pursuant to the Class A Trust Agreement.

“Class A Trust Agreement” means the Basic Agreement, as supplemented by the Trust Supplement No. 2019-1A thereto, governing the creation and administration of the Sun Country Pass Through Trust 2019-1A and the issuance of the Class A Certificates, as the same may be amended, supplemented or otherwise modified from time to time in accordance with its terms.

“Class A Trustee” means WTNA, not in its individual capacity except as expressly set forth in the Class A Trust Agreement, but solely as trustee under the Class A Trust Agreement, together with any successor trustee appointed pursuant thereto.

“Class B Adjusted Interest” means, as of any Current Distribution Date: (I) any interest described in clause (II) of this definition accruing prior to the immediately preceding Distribution Date which remains unpaid and (II) interest at the Stated Interest Rate for the Class B Certificates (A) for the number of days during the period commencing on, and including, the immediately preceding Distribution Date (or, if the Current Distribution Date is the first Distribution Date, the Initial Closing Date) and ending on, but excluding the Current Distribution Date, on the Preferred B Pool Balance on such Current Distribution Date and (B) on the principal amount calculated pursuant to clauses (B)(i), (ii), (iii) and (iv) of the definition of Preferred B Pool Balance for each Series B Equipment Note with respect to which a disposition, distribution, sale or Deemed Disposition Event has occurred since the immediately preceding Distribution Date (but only if no such event has previously occurred with respect to such Series B Equipment Note), for each day during the period, for each such Series B Equipment Note, commencing on, and including, the immediately preceding Distribution Date (or, if the Current Distribution Date is the first Distribution Date, the Initial Closing Date) and ending on, but excluding the date of disposition, distribution, sale or Deemed Disposition Event with respect to such Series B Equipment Note, Aircraft or Collateral, as the case may be.

“Class B Certificateholder” means, at any time, any holder of one or more Class B Certificates.

“Class B Certificates” means the certificates issued by the Class B Trust, substantially in the form of Exhibit A to the Class B Trust Agreement, and authenticated by the Class B Trustee, representing fractional undivided interests in the Class B Trust, and any certificates issued in exchange therefor or replacement thereof pursuant to the terms of the Class B Trust Agreement.

“Class B Trust” means the Sun Country Pass Through Trust 2019-1B created and administered pursuant to the Class B Trust Agreement.

“Class B Trust Agreement” means the Basic Agreement, as supplemented by the Trust Supplement No. 2019-1B thereto, governing the creation and administration of the Sun Country Pass Through Trust 2019-1B and the issuance of the Class B Certificates, as the same may be amended, supplemented or otherwise modified from time to time in accordance with its terms.

“Class B Trustee” means WTNA, not in its individual capacity except as expressly set forth in the Class B Trust Agreement, but solely as trustee under the Class B Trust Agreement, together with any successor trustee appointed pursuant thereto.

“Class C Adjusted Interest” means, as of any Current Distribution Date: (I) any interest described in clause (II) of this definition accruing prior to the immediately preceding Distribution Date which remains unpaid and (II) interest at the Stated Interest Rate for the Class C Certificates (which, in respect of the Deposits and any Pool Balance attributable thereto, shall be without duplication of commitment fees pursuant to Section 1.3 of the Certificate Purchase Agreement in lieu of such interest) (A) for the number of days during the period commencing on, and including, the immediately preceding Distribution Date (or, if the Current Distribution Date is the first Distribution Date, the Initial Funding Date) and ending on, but excluding the Current Distribution Date, on the Preferred C Pool Balance on such Current Distribution Date and (B) on the principal amount calculated pursuant to clauses (B)(i), (ii), (iii) and (iv) of the definition of Preferred C Pool Balance for each Series C Equipment Note with respect to which a disposition, distribution, sale or Deemed Disposition Event has occurred since the immediately preceding

Distribution Date (but only if no such event has previously occurred with respect to such Series C Equipment Note), for each day during the period, for each such Series C Equipment Note, commencing on, and including, the immediately preceding Distribution Date (or, if the Current Distribution Date is the first Distribution Date, the Initial Funding Date) and ending on, but excluding the date of disposition, distribution, sale or Deemed Disposition Event with respect to such Series C Equipment Note, Aircraft or Collateral, as the case may be.

“Class C Certificateholder” means, at any time, any holder of one or more Class C Certificates.

“Class C Certificates” means the certificates issued by the Class C Trust, substantially in the form of Exhibit A to the Class C Trust Agreement, and authenticated by the Class C Trustee, representing fractional undivided interests in the Class C Trust, and any certificates issued in exchange therefor or replacement thereof pursuant to the terms of the Class C Trust Agreement.

“Class C Trust” means the Sun Country Pass Through Trust 2019-1C created and administered pursuant to the Class C Trust Agreement.

“Class C Trust Agreement” means the Basic Agreement, as supplemented by the Trust Supplement No. 2019-1C thereto, governing the creation and administration of the Sun Country Pass Through Trust 2019-1C and the issuance of the Class C Certificates, as the same may be amended, supplemented or otherwise modified from time to time in accordance with its terms.

“Class C Trustee” means WTNA, not in its individual capacity except as expressly set forth in the Class C Trust Agreement, but solely as trustee under the Class C Trust Agreement, together with any successor trustee appointed pursuant thereto.

“Closing Date” has the meaning specified in the Note Purchase Agreement.

“Code” means the Internal Revenue Code of 1986, as amended from time to time, and the Treasury Regulations promulgated thereunder.

“Collateral” has the meaning specified in the Indentures.

“Collection Account” means the Eligible Deposit Account established by the Subordination Agent pursuant to Section 2.2(a)(i) which the Subordination Agent shall make deposits in and withdrawals from in accordance with this Agreement.

“Controlling Party” means the Person entitled to act as such pursuant to the terms of Section 2.6.

“Corporate Trust Office” means, with respect to any Trustee, the Subordination Agent or any Loan Trustee, the office of such Person in the city at which, at any particular time, its corporate trust business shall be principally administered.

“Current Distribution Date” means a Distribution Date specified as a reference date for calculating the Expected Distributions with respect to the Certificates of any Trust as of such Distribution Date.

“Deemed Disposition Event” means, in respect of any Equipment Note, the continuation of an Indenture Default in respect of such Equipment Note without an Actual Disposition Event occurring in respect of such Equipment Note for a period of five years from the date of the occurrence of such Indenture Default.

“Deposit Agreement” means, with respect to the Class C Certificates, the Deposit Agreement, dated as of the date hereof, between the Depository and the Class C Trustee, as the same may be amended, modified or supplemented from time to time in accordance with the terms thereof.

“Depository” means WTNA, as depository under the Deposit Agreement.

“Deposits”, has the meaning set forth in the Deposit Agreement.

“Designated Representatives” means the Subordination Agent Representatives and the Trustee Representatives identified under Section 2.5.

“Distribution Date” means a Regular Distribution Date or a Special Distribution Date.

“Dollars” or “\$” means United States dollars.

“Eligible Deposit Account” means either (a) a segregated account with an Eligible Institution or (b) a segregated trust account with the corporate trust department of a depository institution organized under the laws of the United States of America or any one of the states thereof or the District of Columbia (or any U.S. branch of a foreign bank), having corporate trust powers and acting as trustee for funds deposited in such account, so long as any of the securities of such depository institution has a long-term unsecured debt rating of at least A3 from Moody’s and a long-term issuer credit rating of at least A- from Fitch.

“Eligible Institution” means (a) the corporate trust department of the Subordination Agent or any Trustee, as applicable, or (b) a depository institution organized under the laws of the United States of America or any one of the states thereof or the District of Columbia (or any U.S. branch of a foreign bank), which has a long-term unsecured debt rating from Moody’s of at least A3 or its equivalent or a long-term issuer credit rating from Fitch of at least A- or its equivalent.

“Eligible Investments” means (a) investments in obligations of, or guaranteed by, the United States government having maturities no later than 90 days following the date of such investment, (b) investments in open market commercial paper of any corporation incorporated under the laws of the United States of America or any state thereof with a short-term issuer credit rating issued by Moody’s and Fitch of at least P-1 and F1, respectively, having maturities no later than 90 days following the date of such investment or (c) investments in negotiable certificates of deposit, time deposits, banker’s acceptances, commercial paper or other direct

obligations of, or obligations guaranteed by, commercial banks organized under the laws of the United States or of any political subdivision thereof (or any U.S. branch of a foreign bank) with a short-term unsecured debt rating by Moody's of at least P-1 and a short-term issuer credit rating by Fitch of at least F1, having maturities no later than 90 days following the date of such investment; provided, however, that (x) all Eligible Investments that are bank obligations shall be denominated in Dollars; and (y) the aggregate amount of Eligible Investments at any one time that are bank obligations issued by any one bank shall not be in excess of 5% of such bank's capital surplus; provided further that any investment of the types described in clauses (a), (b) and (c) above may be made through a repurchase agreement in commercially reasonable form with a bank or other financial institution qualifying as an Eligible Institution so long as such investment is held by a third party custodian also qualifying as an Eligible Institution; provided further, however, that in the case of any Eligible Investment issued by a domestic branch of a foreign bank, the income from such investment shall be from sources within the United States for purposes of the Code. Notwithstanding the foregoing, no investment of the types described in clause (b) above which is issued or guaranteed by Sun Country or any of its Affiliates, and no investment in the obligations of any one bank in excess of \$10,000,000, shall be an Eligible Investment unless a Ratings Confirmation (if applicable) shall have been received with respect to the making of such investment.

"Equipment Note Special Payment" means a Special Payment on account of the redemption, purchase or prepayment of Equipment Notes issued pursuant to an Indenture.

"Equipment Notes" means, at any time, the Series A Equipment Notes, Series B Equipment Notes and the Series C Equipment Notes, collectively, and in each case, any Equipment Notes issued in exchange therefor or replacement thereof pursuant to the terms of Indentures.

"Expected Distributions" means, with respect to the Certificates of any Trust on any Current Distribution Date, the difference between (A) the Pool Balance of such Certificates as of the immediately preceding Distribution Date (or, if the Current Distribution Date is the first Distribution Date, (x) for the Class A Trust or the Class B Trust, the sum of the original principal amounts of the Equipment Notes having been purchased on or before such date by such Trust relating to such Certificates and (y) for Class C Trust, the original aggregate face amount of the Certificates of such Trust) and (B) the Pool Balance of such Certificates as of the Current Distribution Date calculated on the basis that (i) the principal of the Non-Performing Equipment Notes held in such Trust has been paid in full and such payments have been distributed to the holders of such Certificates, (ii) the principal of the Performing Equipment Notes held in such Trust has been paid when due (without giving effect to any Acceleration of Performing Equipment Notes) and such payments have been distributed to the holders of such Certificates and (iii) the principal of any Equipment Notes formerly held in such Trust that have been sold pursuant to the terms hereof has been paid in full and such payments have been distributed to the holders of such Certificates, but without giving effect to any reduction in the Pool Balance as a result of any distribution attributable to Deposits occurring after the immediately preceding Distribution Date (or, if the Current Distribution Date is the first Distribution Date, occurring after the initial issuance of the Certificates of such Trust). For purposes of calculating Expected Distributions with respect to the Certificates of any Trust, any Premium paid on the Equipment Notes held in such Trust which has not been distributed to the Certificateholders of such Trust (other than such Premium or a portion thereof applied to the payment of interest, commitment fees, or PIK Amounts on the Certificates of such Trust or the reduction of the Pool Balance of such Trust) shall be added to the amount of such Expected Distributions.

“Final Distributions” means, with respect to the Certificates of any Trust on any Distribution Date, the sum of (x) the aggregate amount of all accrued and unpaid interest on such Certificates (including any PIK Amounts, but in the case of the Class C Trust, excluding the commitment fees, if any, payable with respect to the Deposits relating to such Trust) and (y) the Pool Balance of such Certificates as of the immediately preceding Distribution Date (and in the case of the Class C Certificates, less the amount of the Deposits as of such preceding Distribution Date other than any portion of such Deposits thereafter used to acquire the Series C Equipment Notes pursuant to the Note Purchase Agreement). For purposes of calculating Final Distributions with respect to the Certificates of any Trust, any Premium paid on the Equipment Notes held in such Trust which has not been distributed to the Certificateholders of such Trust (other than such Premium or a portion thereof applied to the payment of interest or PIK Amounts on the Certificates of such Trust or the reduction of the Pool Balance of such Trust) shall be added to the amount of such Final Distributions.

“Final Legal Distribution Date” means (i) with respect to the Class A Certificates, June 15, 2029, (ii) with respect to the Class B Certificates, June 15, 2027 and (iii) with respect to the Class C Certificates, December 15, 2023.

“Financing Agreement” means each of the Participation Agreements, the Indentures and the Note Purchase Agreement.

“Fitch” means Fitch Ratings, Inc.

“Indenture” means each of the Trust Indentures entered into by the Loan Trustee and Sun Country, pursuant to the Note Purchase Agreement, in each case as the same may be amended, supplemented or otherwise modified from time to time in accordance with its terms.

“Indenture Default” means, with respect to any Indenture, any Event of Default (as such term is defined in such Indenture) thereunder.

“Initial Closing Date” has the meaning specified in the Note Purchase Agreement.

“Initial Funding Date” means December 16, 2019.

“Investment Earnings” means investment earnings on funds on deposit in the Trust Accounts net of losses and investment expenses of the Subordination Agent in making such investments.

“Lien” means any mortgage, pledge, lien, charge, claim, disposition of title, encumbrance, lease, sublease, sub-sublease or security interest of any kind, including, without limitation, any thereof arising under any conditional sales or other title retention agreement.

“Loan Trustee” means, with respect to any Indenture, the mortgagee thereunder.

“Minimum Sale Price” means, with respect to any Aircraft or the Equipment Notes issued in respect of such Aircraft, at any time, in the case of the sale of an Aircraft, 75%, or in the case of the sale of related Equipment Notes, 85%, of the Appraised Current Market Value of such Aircraft.

“Moody’s” means Moody’s Investors Service, Inc.

“Non-Controlling Party” means, at any time, any Trustee or other Person which is not the Controlling Party at such time.

“Non-Performing Equipment Note” means an Equipment Note issued pursuant to an Indenture that is not a Performing Equipment Note.

“Note Purchase Agreement” means the Note Purchase Agreement, dated as of the date hereof, among Sun Country, each Trustee, the Depository and the Subordination Agent, as amended, supplemented or otherwise modified from time to time in accordance with its terms.

“Operative Agreements” means this Agreement, the Trust Agreements, the Certificate Purchase Agreement, the Financing Agreements, the Equipment Notes and the Certificates, together with all exhibits and schedules included with any of the foregoing.

“Outstanding” means, when used with respect to each Class of Certificates, as of the date of determination, all Certificates of such Class theretofore authenticated and delivered under the related Trust Agreement, except:

(i) Certificates of such Class theretofore canceled by the Registrar (as defined in such Trust Agreement) or delivered to the Trustee thereunder or such Registrar for cancellation;

(ii) Certificates of such Class for which money in the full amount required to make the Final Distribution with respect to such Certificates pursuant to Section 11.01 of such Trust Agreement has been theretofore deposited with the related Trustee in trust for the holders of such Certificates as provided in Section 4.01 of such Trust Agreement pending distribution of such money to such Certificateholders pursuant to such Final Distribution payment; and

(iii) Certificates of such Class in exchange for or in lieu of which other Certificates have been authenticated and delivered pursuant to such Trust Agreement;

provided, however, that in determining whether the holders of the requisite Outstanding amount of such Certificates have given any request, demand, authorization, direction, notice, consent or waiver hereunder, any Certificates owned by Sun Country or any of its Affiliates shall be disregarded and deemed not to be Outstanding, except that, in determining whether such Trustee shall be protected in relying upon any such request, demand, authorization, direction, notice, consent or waiver, only Certificates that such Trustee knows to be so owned shall be so disregarded. Certificates so owned that have been pledged in good faith may be regarded as Outstanding if the pledgee establishes to the satisfaction of the applicable Trustee the pledgee’s right so to act with respect to such Certificates and that the pledgee is not Sun Country or any of its Affiliates.



“Overdue Scheduled Payment” means any Scheduled Payment which is not in fact received by the Subordination Agent within five days after the Scheduled Payment Date relating thereto.

“Participation Agreement” means, with respect to each Indenture, the “Participation Agreement” referred to therein.

“Payees” has the meaning specified in Section 2.4(c).

“Performing Equipment Note” means an Equipment Note with respect to which no payment default has occurred and is continuing (without giving effect to any Acceleration); provided that in the event of a bankruptcy proceeding under the Bankruptcy Code in which Sun Country is a debtor any payment default existing during the 60-Day Period (or such longer period as may apply under Section 1110(b) of the Bankruptcy Code or as may apply for the cure of such payment default under Section 1110(a)(2)(B) of the Bankruptcy Code) shall not be taken into consideration until the expiration of the applicable period.

“Performing Note Deficiency” means any time that less than 65% of the then aggregate outstanding principal amount of all Equipment Notes (other than any Additional Equipment Notes issued under any Indenture) are Performing Equipment Notes.

“Person” means any individual, corporation, partnership, joint venture, association, limited liability company, joint-stock company, trust, trustee, unincorporated organization or government or any agency or political subdivision thereof.

“PIK Amounts” means, with respect to Class A Certificates and the Class B Certificates, as of any date of determination, any interest on the Pool Balance of the Certificates of such Class that was scheduled for distribution on any applicable Regular Distribution Date and was not paid on such Regular Distribution Date (and remains unpaid as of such date of determination) together with any interest accrued thereon at the Stated Interest Rate for the applicable Class.

“Pool Balance” means, with respect to each Trust or the Certificates issued by any Trust, as of any date, (i) (x) with respect to the Class A Trust (and Class A Certificates) or the Class B Trust (and Class B Certificates), the sum of the original principal amounts of the Equipment Notes having been purchased on or before such date by such Trust relating to such Certificates, and (y) with respect to the Class C Trust (and Class C Certificates), the original aggregate face amount of the Certificates of such Trust, less (ii) the aggregate amount of all payments made as of such date in respect of the Certificates of such Trust or, in the case of the Class C Certificates, in respect of Deposits, other than payments made in respect of interest, commitment fees, PIK Amounts or Premium thereon or reimbursement of any costs and expenses in connection therewith. The Pool Balance for each Trust or for the Certificates issued by any Trust as of any date shall be computed after giving effect to any special distribution with respect to unused Deposits (in the case of the Class C Certificates), if any, any payment of principal of the Equipment Notes or payment with respect to other Trust Property held in such Trust and the distribution thereof to be made on that date.

“Post-Default Appraisals” has the meaning specified in Section 4.1(a)(iv).

“Preferred B Pool Balance” means, as of any date, the excess of (A) the Pool Balance of the Class B Certificates as of the immediately preceding Distribution Date (or, if such date is on or before the first Distribution Date, the sum of the original principal amounts of the Series B Equipment Notes having been purchased on or before such date by the Class B Trust) (after giving effect to distributions made on such date) over (B) the sum of (i) the outstanding principal amount of each Series B Equipment Note that remains unpaid as of such date subsequent to the disposition of the Collateral under the Indenture pursuant to which such Series B Equipment Note was issued and after giving effect to any distributions of the proceeds of such disposition applied under such Indenture to the payment of each such Series B Equipment Note, (ii) the outstanding principal amount of each Series B Equipment Note that remains unpaid as of such date subsequent to the scheduled date of mandatory redemption of such Series B Equipment Note following an Event of Loss (as defined in such Indenture) with respect to the Aircraft which secured such Series B Equipment Note and after giving effect to the distributions of any proceeds in respect of such Event of Loss applied under such Indenture to the payment of each such Series B Equipment Note, (iii) the excess, if any, of (x) the outstanding amount of principal and interest as of the date of sale of each Series B Equipment Note previously sold over (y) the purchase price received with respect to the sale of such Series B Equipment Note (net of any applicable costs and expenses of sale) and (iv) the outstanding principal amount of any Series B Equipment Note with respect to which a Deemed Disposition Event has occurred; provided, however, that if more than one of the clauses (i), (ii), (iii) and (iv) is applicable to any one Series B Equipment Note, only the amount determined pursuant to the clause that first became applicable shall be counted with respect to such Series B Equipment Note.

“Preferred C Pool Balance” means, as of any date, the excess of (A) the Pool Balance of the Class C Certificates as of the immediately preceding Distribution Date (or, if such date is on or before the first Distribution Date, the original aggregate face amount of the Class C Certificates) (after giving effect to distributions made on such date) over (B) the sum of (i) the outstanding principal amount of each Series C Equipment Note that remains unpaid as of such date subsequent to the disposition of the Collateral under the Indenture pursuant to which such Series C Equipment Note was issued and after giving effect to any distributions of the proceeds of such disposition applied under such Indenture to the payment of each such Series C Equipment Note, (ii) the outstanding principal amount of each Series C Equipment Note that remains unpaid as of such date subsequent to the scheduled date of mandatory redemption of such Series C Equipment Note following an Event of Loss (as defined in such Indenture) with respect to the Aircraft which secured such Series C Equipment Note and after giving effect to the distributions of any proceeds in respect of such Event of Loss applied under such Indenture to the payment of each such Series C Equipment Note, (iii) the excess, if any, of (x) the outstanding amount of principal and interest as of the date of sale of each Series C Equipment Note previously sold over (y) the purchase price received with respect to the sale of such Series C Equipment Note (net of any applicable costs and expenses of sale) and (iv) the outstanding principal amount of any Series C Equipment Note with respect to which a Deemed Disposition Event has occurred; provided, however, that if more than one of the clauses (i), (ii), (iii) and (iv) is applicable to any one Series C Equipment Note, only the amount determined pursuant to the clause that first became applicable shall be counted with respect to such Series C Equipment Note.

“Premium” means (i) any “Make-Whole Amount” as such term is defined in any Indenture and (ii) any redemption purchase price in respect of principal (disregarding interest) in excess of 100% in relation to a “Change of Control Prepayment” as such term is defined in any Indenture, and (iii) for any of MSN 30706, MSN 30620 and MSN 28249, any redemption purchase price in respect of principal (disregarding interest) in excess of 100% pursuant to Section 2.11(e) of the applicable Indenture.

“Proceeding” means any suit in equity, action at law or other judicial or administrative proceeding.

“PTC Event of Default” means, with respect to each Trust Agreement, the failure to pay within 10 Business Days after the due date thereof: (i) the outstanding Pool Balance of the applicable Class of Certificates on the Final Legal Distribution Date for such Class or (ii) any PIK Amount on the earlier of (A) the Regular Distribution Date that is the third Regular Distribution Date following the Regular Distribution Date on which the interest represented by such PIK Amount was originally scheduled to be distributed and (B) the date that is 18 months prior to the Final Legal Distribution Date.

“Purchaser” has the meaning assigned to such term in the Certificate Purchase Agreement.

“Rating Agency” means, at any time, any nationally recognized rating agency which shall have been requested to rate the Certificates and which shall then be rating the Certificates. The initial Rating Agency will be Kroll Bond Rating Agency.

“Ratings Confirmation” means, with respect to any action proposed to be taken, a written confirmation from each Rating Agency that such action would not result in (i) a reduction of the rating for any Class of Certificates then rated by such Rating Agency below the then current rating for such Class of Certificates or (ii) a withdrawal or suspension of the rating of any Class of Certificates then rated by such Rating Agency. For avoidance of doubt, no Ratings Confirmation shall be required in respect of any Class of Certificates that is not rated by a Rating Agency at the time of any such proposed action.

“Refinancing Certificateholders” has the meaning specified in Section 9.1(c).

“Refinancing Certificates” has the meaning specified in Section 9.1(c).

“Refinancing Equipment Notes” has the meaning specified in Section 9.1(c).

“Refinancing Trust Agreement” has the meaning specified in Section 9.1(c).

“Refinancing Trust” has the meaning specified in Section 9.1(c).

“Refinancing Trustee” has the meaning specified in Section 9.1(c).

“Regular Distribution Dates” means each June 15 and December 15, commencing on June 15, 2020; provided, however, that, if any such day shall not be a Business Day, the related distribution shall be made on the next succeeding Business Day without distribution of interest for such additional period.

“Responsible Officer” means, with respect to the Subordination Agent and each of the Trustees, any officer in the corporate trust administration department of the Subordination Agent or such Trustee or any other officer customarily performing functions similar to those performed by the Persons who at the time shall be such officers, respectively, or to whom any corporate trust matter is referred because of his knowledge of and familiarity with a particular subject.

“Scheduled Payment” means, with respect to any Equipment Note, any payment of principal or interest on such Equipment Note (other than an Overdue Scheduled Payment) due from the obligor thereon, which payment represents the installment of principal at the stated maturity of such installment of principal on such Equipment Note, the payment of regularly scheduled interest accrued on the unpaid principal amount of such Equipment Note, or both or; provided that any payment of principal of, Premium, if any, or interest resulting from the redemption or purchase of any Equipment Note shall not constitute a Scheduled Payment.

“Scheduled Payment Date” means, with respect to any Scheduled Payment, the date on which such Scheduled Payment is scheduled to be made.

“Series A Equipment Notes” means the Series A Equipment Notes issued pursuant to any Indenture by Sun Country and authenticated by the Loan Trustee thereunder, and any such Equipment Notes issued in exchange therefor or replacement thereof pursuant to the terms of such Indenture.

“Series B Equipment Notes” means the Series B Equipment Notes issued pursuant to any Indenture by Sun Country and authenticated by the Loan Trustee thereunder, and any such Equipment Notes issued in exchange therefor or replacement thereof pursuant to the terms of such Indenture.

“Series C Equipment Notes” means the Series C Equipment Notes issued pursuant to any Indenture by Sun Country and authenticated by the Loan Trustee thereunder, and any such Equipment Notes issued in exchange therefor or replacement thereof pursuant to the terms of such Indenture.

“60-Day Period” means the 60-day period specified in Section 1110(a)(2)(A) of the Bankruptcy Code.

“Special Distribution Date” means, with respect to any Special Payment, the date chosen by the Subordination Agent pursuant to Section 2.4(a) for the distribution of such Special Payment in accordance with this Agreement, whether distributed pursuant to Section 2.4 or Section 3.2 hereof.

“Special Payment” means any payment (other than a Scheduled Payment) in respect of, or any proceeds of, any Equipment Note or Collateral.

“Stated Interest Rate” means (i) with respect to the Class A Certificates, a per annum rate for any day equivalent to the weighted average interest rate (determined for such purpose based on the applicable Debt Rate as defined in each Indenture) of the Series A Equipment Notes held by the Class A Trust on such day, (ii) with respect to the Class B Certificates, a per annum rate for any day equivalent to the weighted average interest rate (determined for such purpose based on the applicable Debt Rate as defined in each Indenture) of the Series B Equipment Notes held by the Class B Trust on such day and (iii) with respect to the Class C Certificates, 6.95% per annum.

“Subordination Agent” has the meaning specified in the preamble to this Agreement.

“Subordination Agent Incumbency Certificate” has the meaning specified in Section 2.5(a).

“Subordination Agent Representatives” has the meaning specified in Section 2.5(a).

“Sun Country” means Sun Country, Inc., a Minnesota corporation, and its successors and assigns.

“Sun Country Provisions” has the meaning specified in Section 9.1(a).

“Tax” and “Taxes” mean any and all taxes, fees, levies, duties, tariffs, imposts, and other charges of any kind (together with any and all interest, penalties, loss, damage, liability, expense, additions to tax and additional amounts or costs incurred or imposed with respect thereto) imposed or otherwise assessed by the United States of America or by any state, local or foreign government (or any subdivision or agency thereof) or other taxing authority, including, without limitation: taxes or other charges on or with respect to income, franchises, windfall or other profits, gross receipts, property, sales, use, capital stock, payroll, employment, social security, workers’ compensation, unemployment compensation, or net worth and similar charges; taxes or other charges in the nature of excise, withholding, ad valorem, stamp, transfer, value added, taxes on goods and services, gains taxes, license, registration and documentation fees, customs duties, tariffs, and similar charges.

“Treasury Regulations” means regulations, including proposed or temporary regulations, promulgated under the Code. References herein to specific provisions of proposed or temporary regulations shall include analogous provisions of final Treasury Regulations or other successor Treasury Regulations.

“Triggering Event” means (x) the occurrence of an Indenture Default under all of the Indentures resulting in a PTC Event of Default with respect to the most senior Class of Certificates then Outstanding, (y) the Acceleration of all of the outstanding Equipment Notes or (z) the occurrence of a Bankruptcy Event.

“Trust” means any of the Class A Trust, the Class B Trust or the Class C Trust.

“Trust Accounts” has the meaning specified in Section 2.2(a).

“Trust Agreement” means the Class A Trust Agreement, the Class B Trust Agreement or the Class C Trust Agreement.

“Trust Property”, with respect to any Trust, has the meaning set forth in the Trust Agreement for such Trust.

“Trustee” means any of the Class A Trustee, the Class B Trustee or the Class C Trustee.

“Trustee Incumbency Certificate” has the meaning specified in Section 2.5(b).

“Trustee Representatives” has the meaning specified in Section 2.5(b).

“Written Notice” means, from the Subordination Agent or the any Trustee, a written instrument executed by the Designated Representative of such Person.

“WTNA” has the meaning specified in the recitals to this Agreement.

## ARTICLE II

### TRUST ACCOUNTS; CONTROLLING PARTY

SECTION 2.1. Agreement to Terms of Subordination; Payments from Monies Received Only. (a) Each Trustee hereby acknowledges and agrees to the terms of subordination and distribution set forth in this Agreement in respect of each Class of Certificates and agrees to enforce such provisions and cause all payments in respect of the Equipment Notes held by the Subordination Agent to be applied in accordance with the terms of this Agreement. In addition, each Trustee hereby agrees to cause the Equipment Notes purchased by the related Trust to be registered in the name of the Subordination Agent or its nominee, as agent and trustee for such Trustee, to be held in trust by the Subordination Agent solely for the purpose of facilitating the enforcement of the subordination and other provisions of this Agreement.

(b) Except as otherwise expressly provided in the next succeeding sentence of this Section 2.1(b), all payments to be made by the Subordination Agent hereunder shall be made only from amounts received by it that constitute Scheduled Payments, Special Payments, payments under Section 8.1 of the Participation Agreements, or payments under Section 6 of the Note Purchase Agreement and only to the extent that the Subordination Agent shall have received sufficient income or proceeds therefrom to enable it to make such payments in accordance with the terms hereof. Each of the Trustees and the Subordination Agent hereby agrees and, as provided in each Trust Agreement, each Certificateholder, by its acceptance of a Certificate, has agreed to look solely to such amounts to the extent available for distribution to it as provided in this Agreement and to the relevant Deposits and that none of the Trustees, the Loan Trustees and the Subordination Agent is personally liable to any of them for any amounts payable or any liability under this Agreement, any Trust Agreement, or such Certificate, except (in the case of the Subordination Agent) as expressly provided herein or (in the case of the Trustees) as expressly provided in each Trust Agreement or (in the case of the Loan Trustees) as expressly provided in any Operative Agreement.

SECTION 2.2. Trust Accounts. (a) Upon the execution of this Agreement, the Subordination Agent shall establish and maintain in its name (i) the Collection Account as an Eligible Deposit Account, bearing a designation clearly indicating that the funds deposited therein are held in trust for the benefit of the Trustees and the Certificateholders and (ii) as a sub-account in the Collection Account, the Special Payments Account as an Eligible Deposit Account, bearing a designation clearly indicating that the funds deposited therein are held in trust for the benefit of the Trustees and the Certificateholders. The Special Payments Account and the Collection Account, constitute the “Trust Accounts” hereunder. Without limiting the foregoing, all monies credited to the Trust Accounts shall be, and shall remain, the property of the relevant Trust(s).

(b) Funds on deposit in the Trust Accounts shall be invested and reinvested by the Subordination Agent in Eligible Investments selected by the Subordination Agent if such investments are reasonably available and have maturities no later than the earlier of (i) 90 days following the date of such investment and (ii) the Business Day immediately preceding the Regular Distribution Date or the date of the related distribution pursuant to Section 2.4 hereof, as the case may be, next following the date of such investment; provided, however, that upon the occurrence and during the continuation of a Triggering Event, the Subordination Agent shall invest and reinvest such amounts in Eligible Investments in accordance with the written instructions of the Controlling Party. Unless otherwise expressly provided in this Agreement, any Investment Earnings shall be deposited in the Collection Account when received by the Subordination Agent and shall be applied by the Subordination Agent in the same manner as the other amounts on deposit in the Collection Account are to be applied and any losses shall be charged against the principal amount invested, in each case net of the Subordination Agent’s reasonable fees and expenses in making such investments. The Subordination Agent shall not be liable for any loss resulting from any investment, reinvestment or liquidation required to be made under this Agreement other than by reason of its willful misconduct or gross negligence (or, with respect to the handling or transfer of funds, its own negligence). Eligible Investments and any other investment required to be made hereunder shall be held to their maturities except that any such investment may be sold (without regard to its maturity) by the Subordination Agent without instructions whenever such sale is necessary to make a distribution required under this Agreement. Uninvested funds held hereunder shall not earn or accrue interest.

(c) The Subordination Agent shall possess all right, title and interest in all funds on deposit from time to time in the Trust Accounts and in all proceeds thereof (including all income thereon, except as otherwise expressly provided in Section 3.3(b) with respect to Investment Earnings). The Trust Accounts shall be held in trust by the Subordination Agent under the sole dominion and control of the Subordination Agent for the benefit of the Trustees and the Certificateholders, as the case may be. If, at any time, any of the Trust Accounts ceases to be an Eligible Deposit Account, the Subordination Agent shall within 10 Business Days (or such longer period, not to exceed 30 calendar days, for which a Ratings Confirmation for each then rated Class of Certificates shall have been obtained) establish a new Collection Account or Special Payments Account, as the case may be, as an Eligible Deposit Account and shall transfer any cash and/or any investments to such new Collection Account or Special Payments, as the case may be. So long as WTNA is an Eligible Institution, the Trust Accounts shall be maintained with it as Eligible Deposit Accounts.

SECTION 2.3. Deposits to the Collection Account and Special Payments Account. (a) The Subordination Agent shall, upon receipt thereof, deposit in the Collection Account all Scheduled Payments received by it.

(b) The Subordination Agent shall, on each date when one or more Special Payments are made to the Subordination Agent as holder of the Equipment Notes, deposit in the Special Payments Account the aggregate amount of such Special Payments.

SECTION 2.4. Distributions of Special Payments. (a) Notice of Special Payment. Except as provided in Section 2.4(c) below, upon receipt by the Subordination Agent, as registered holder of the Equipment Notes, of any notice of a Special Payment (or, in the absence of any such notice, upon receipt by the Subordination Agent of a Special Payment), the Subordination Agent shall promptly give notice thereof to each Trustee. The Subordination Agent shall promptly calculate the amount of the redemption or purchase of Equipment Notes, the amount of any Overdue Scheduled Payment or the proceeds of Equipment Notes or Collateral, as the case may be, comprising such Special Payment under the applicable Indenture or Indentures and shall promptly send to each Trustee a Written Notice of such amount and the amount allocable to each Trust. Such Written Notice shall also set the distribution date for such Special Payment (a “Special Distribution Date”), which shall be the Business Day which immediately follows the later to occur of (x) the 15th day after the date of such Written Notice and (y) the date the Subordination Agent has received or expects to receive such Special Payment. Amounts on deposit in the Special Payments Account shall be distributed in accordance with Sections 2.4(b) and 2.4(c) and Article III hereof, as applicable.

For the purposes of the application of any Equipment Note Special Payment distributed on a Special Distribution Date in accordance with Section 3.2 hereof, so long as no Indenture Default shall have occurred and be continuing under any Indenture:

(i) clause “third” thereof shall be deemed to read as follows: “third, such amount as shall be required to pay any accrued and unpaid PIK Amounts (applied first to interest and then principal) in respect of the Class A Certificates and then accrued, due and unpaid interest at the Stated Interest Rate on the outstanding Pool Balance of the Class A Certificates, together with (without duplication) accrued and unpaid interest at the Stated Interest Rate on the outstanding principal amount of (and determined for such purposes based only on) the Series A Equipment Notes held in the Class A Trust being redeemed, purchased or prepaid, shall be distributed to the Class A Trustee”;

(ii) clause “fourth” thereof shall be deemed to read as follows: “fourth, such amount as shall be required to pay any accrued and unpaid PIK Amounts (applied first to interest and then principal) in respect of the Class B Certificates and then accrued, due and unpaid Class B Adjusted Interest, shall be distributed to the Class B Trustee”;

(iii) clause “fifth” thereof shall be deemed to read as follows: “fifth, such amount as shall be required to pay any accrued, due and unpaid Class C Adjusted Interest shall be distributed to the Class C Trustee, in each case excluding commitment fees, if any, payable with respect to the Deposits”;



(iv) clause “seventh” thereof shall be deemed to read as follows: “seventh, such amount as shall be required to pay in full accrued, due and unpaid interest at the Stated Interest Rate on the outstanding Pool Balance of the Class B Certificates which was not previously paid pursuant to clause “fourth” above, together with (without duplication) accrued and unpaid interest at the Stated Interest Rate on the outstanding principal amount of (and determined for such purposes based only on) the Series B Equipment Notes held in the Class B Trust and being redeemed, purchased or prepaid, shall be distributed to the Class B Trustee”; and

(v) clause “ninth” thereof shall be deemed to read as follows: “ninth, such amount as shall be required to pay in full accrued, due and unpaid interest at the Stated Interest Rate on the outstanding Pool Balance of the Class C Certificates which was not previously paid pursuant to clause “fifth” above, together with (without duplication) accrued and unpaid interest at the Stated Interest Rate on the outstanding principal amount of the Series C Equipment Notes held in the Class C Trust and being redeemed, purchased or prepaid, in each case excluding commitment fees, if any, payable with respect to the Deposits, shall be distributed to the Class C Trustee”.

(b) Investment of Amounts in Special Payments Account. Any amounts on deposit in the Special Payments Account prior to the distribution thereof pursuant to Section 2.4 or 3.2 shall be invested in accordance with Section 2.2(b). Investment Earnings on such investments shall be distributed in accordance with Article III hereof.

(c) Certain Payments. The Subordination Agent will distribute promptly upon receipt thereof (i) any indemnity payment or expense reimbursement received by it from Sun Country in respect of any Trustee, or the Depository (the “Payees”) and (ii) any compensation received by it from Sun Country under any Operative Agreement in respect of any Payee, directly to the Payee entitled thereto.

SECTION 2.5. Designated Representatives. (a) With the delivery of this Agreement, the Subordination Agent shall furnish to each Trustee, and from time to time thereafter may furnish to each Trustee, at the Subordination Agent’s discretion, or upon any Trustee’s request (which request shall not be made more than one time in any 12-month period), a certificate (a “Subordination Agent Incumbency Certificate”) of a Responsible Officer of the Subordination Agent certifying as to the incumbency and specimen signatures of the officers of the Subordination Agent and the attorney-in-fact and agents of the Subordination Agent (the “Subordination Agent Representatives”) authorized to give Written Notices on behalf of the Subordination Agent hereunder. Until each Trustee receives a subsequent Subordination Agent Incumbency Certificate, it shall be entitled to rely on the last Subordination Agent Incumbency Certificate delivered to it hereunder.

(b) With the delivery of this Agreement, each Trustee shall furnish to the Subordination Agent, and from time to time thereafter may furnish to the Subordination Agent, at such Trustee’s discretion, or upon the Subordination Agent’s request (which request shall not be made more than one time in any 12-month period), a certificate (a “Trustee Incumbency Certificate”) of a Responsible Officer of such Trustee certifying as to the incumbency and specimen signatures of the officers of such Trustee and the attorney-in-fact and agents of such Trustee (the “Trustee Representatives”) authorized to give Written Notices on behalf of such Trustee hereunder. Until the Subordination Agent receives a subsequent Trustee Incumbency Certificate, it shall be entitled to rely on the last Trustee Incumbency Certificate delivered to it hereunder.

SECTION 2.6. Controlling Party. (a) The Trustees hereby agree that, with respect to any Indenture at any given time, the Loan Trustee thereunder will be directed in taking, or refraining from taking, any action under such Indenture or with respect to the Equipment Notes issued thereunder (i) so long as no Indenture Default has occurred and is continuing thereunder, by the holders of at least a majority of the outstanding principal amount of such Equipment Notes (provided that, for so long as the Subordination Agent is the registered holder of the Equipment Notes, the Subordination Agent shall act with respect to this clause (i) in accordance with the directions of the Trustees (in the case of each such Trustee, with respect to the Equipment Notes issued under such Indenture and held as Trust Property of such Trust) constituting, in the aggregate, directions with respect to at least a majority of outstanding principal amount of Equipment Notes except as provided in Section 9.1(b)), and (ii) after the occurrence and during the continuance of an Indenture Default thereunder, in taking, or refraining from taking, any action under such Indenture or with respect to such Equipment Notes, including exercising remedies thereunder (including Accelerating the Equipment Notes issued thereunder or foreclosing the Lien on the Aircraft securing such Equipment Notes), by the Controlling Party.

(b) The “Controlling Party” shall be (i) the Class A Trustee, (ii) upon payment of Final Distributions to the holders of Class A Certificates, the Class B Trustee and (iii) upon payment of Final Distributions to the holders of Class B Certificates, the Class C Trustee. For purposes of giving effect to the provisions of Section 2.6(a) and this Section 2.6(b), the Trustees (other than the Controlling Party) irrevocably agree (and the Certificateholders (other than the Certificateholders represented by the Controlling Party) shall be deemed to agree by virtue of their purchase of Certificates) that the Subordination Agent, as record holder of the Equipment Notes, shall exercise its voting rights in respect of the Equipment Notes so held by the Subordination Agent as directed by the Controlling Party and any vote so exercised shall be binding upon the Trustees and all Certificateholders.

The Subordination Agent shall give Written Notice to all of the other parties to this Agreement promptly upon a change in the identity of the Controlling Party. Each of the parties hereto agrees that it shall not exercise any of the rights of the Controlling Party at such time as it is not the Controlling Party hereunder; provided, however, that nothing herein contained shall prevent or prohibit any Non-Controlling Party from exercising such rights as shall be specifically granted to such Non-Controlling Party hereunder and under the other Operative Agreements.

(c) [Reserved].

(d) The exercise of remedies by the Controlling Party under this Agreement shall be expressly limited by Sections 4.1(a)(ii) and 4.1(a)(iii) hereof.

(e) The Controlling Party shall not be entitled to require or obligate any Non-Controlling Party to provide funds necessary to exercise any right or remedy hereunder.

ARTICLE III

RECEIPT, DISTRIBUTION AND APPLICATION  
OF AMOUNTS RECEIVED

SECTION 3.1. Written Notice of Distribution. (a) No later than 3:00 P.M. (New York City time) on the Business Day immediately preceding each Distribution Date, each of the following Persons shall deliver to the Subordination Agent a Written Notice setting forth the following information as at the close of business on such Business Day:

(i) with respect to the Class A Certificates, the Class A Trustee shall separately set forth the amounts to be paid in accordance with clause “first” of Section 3.2 hereof (to reimburse payments made by such Trustee or the Class A Certificateholders, as the case may be, pursuant to subclause (ii) or (iii) of clause “first”), subclauses (ii) and (iii) of clause “second” of Section 3.2 hereof and clauses “third” and “sixth” of Section 3.2 hereof;

(ii) with respect to the Class B Certificates, the Class B Trustee shall separately set forth the amounts to be paid in accordance with clause “first” of Section 3.2 hereof (to reimburse payments made by such Trustee or the Class B Certificateholders, as the case may be, pursuant to subclause (ii) or (iii) of clause “first”), subclauses (ii) and (iii) of clause “second” of Section 3.2 hereof and clauses “fourth”, “seventh” and “eighth” of Section 3.2 hereof;

(iii) with respect to the Class C Certificates, the Class C Trustee shall separately set forth the amounts to be paid in accordance with clause “first” of Section 3.2 hereof (to reimburse payments made by such Trustee or the Class C Certificateholders, as the case may be, pursuant to subclause (ii) or (iii) of clause “first”), subclauses (ii) and (iii) of clause “second” of Section 3.2 hereof and clauses “fifth”, “ninth” and “tenth” of Section 3.2 hereof and

(iv) each Trustee shall set forth the amounts to be paid in accordance with clause “sixth” of Section 3.2 hereof.

(b) At such time as a Trustee shall have received all amounts owing to it (and, in the case of a Trustee, the Certificateholders for which it is acting) pursuant to Section 3.2 hereof, as applicable, such Person shall, by a Written Notice, so inform the Subordination Agent and each other party to this Agreement.

(c) As provided in Section 6.5 hereof, the Subordination Agent shall be fully protected in relying on any of the information set forth in a Written Notice provided by any Trustee pursuant to paragraphs (a) and (b) above and shall have no independent obligation to verify, calculate or recalculate any amount set forth in any Written Notice delivered in accordance with such paragraphs.

(d) Any Written Notice delivered by a Trustee, or the Subordination Agent, as applicable, pursuant to Section 3.1(a) hereof, if made prior to 10:00 A.M. (New York City time) on any Business Day, shall be effective on the date delivered (or if delivered later on a Business Day or if delivered on a day which is not a Business Day shall be effective as of the next Business Day). Subject to the terms of this Agreement, the Subordination Agent shall as promptly as practicable comply with any such instructions; provided, however, that any transfer of funds pursuant to any instruction received after 10:00 A.M. (New York City time) on any Business Day may be made on the next succeeding Business Day.

(e) In the event the Subordination Agent shall not receive from any Person any information set forth in paragraph (a) above which is required to enable the Subordination Agent to make a distribution to such Person pursuant to Section 3.2 hereof, the Subordination Agent shall request such information and, failing to receive any such information, the Subordination Agent shall not make such distribution(s) to such Person. In such event, the Subordination Agent shall make distributions pursuant to clauses “first” through “eleventh” of Section 3.2 to the extent it shall have sufficient information to enable it to make such distributions, and shall continue to hold any funds remaining, after making such distributions, until the Subordination Agent shall receive all necessary information to enable it to distribute any funds so withheld.

(f) The notices required under Section 3.1(a) may be in the form of a schedule or similar document provided to the Subordination Agent by the parties referenced therein or by any one of them, which schedule or similar document may state that, unless there has been a prepayment of the Certificates, such schedule or similar document is to remain in effect until any substitute notice or amendment shall be given to the Subordination Agent by the party providing such notice.

SECTION 3.2. Distribution of Amounts on Deposit in the Collection Account. Except as otherwise provided in Sections 2.4, 3.1(e), and 3.3, amounts on deposit in the Collection Account (including amounts on deposit in the Special Payments Account) shall be promptly distributed on each Regular Distribution Date (or, in the case of any amount described in Section 2.4(a), on the Special Distribution Date thereof) in the following order of priority and in accordance with the information provided to the Subordination Agent pursuant to Section 3.1(a) hereof:

first, such amount as shall be required to reimburse (i) the Subordination Agent for any reasonable out-of-pocket costs and expenses actually incurred by it (to the extent not previously reimbursed) or reasonably expected to be incurred by it for the period ending on the next succeeding Regular Distribution Date (which shall not exceed \$150,000 unless approved in writing by the Controlling Party) in the protection of, or the realization of the value of, the Equipment Notes or any Collateral, shall be applied by the Subordination Agent in reimbursement of such costs and expenses, (ii) any Trustee for any amounts of the nature described in clause (i) above actually incurred by it under the applicable Trust Agreement (to the extent not previously reimbursed), shall be distributed to such Trustee and (iii) any Certificateholder for payments, if any, made by it to the Subordination Agent or any Trustee in respect of amounts described in clause (i) above actually incurred by it (to the extent not previously reimbursed) (collectively, the “Administration Expenses”), shall be distributed to the applicable Trustee for the account of such Certificateholder, in each such case, pro rata on the basis of all amounts described in clauses (i) and (ii) above;

second, such amount as shall be required to reimburse or pay (i) the Subordination Agent for any Tax (other than Taxes imposed on compensation paid hereunder), expense, fee, charge or other loss incurred by or any other amount payable to the Subordination Agent in connection with the transactions contemplated hereby (to the extent not previously reimbursed), shall be applied by the Subordination Agent in reimbursement of such amount, (ii) each Trustee for any Tax (other than Taxes imposed on compensation paid under the applicable Trust Agreement), expense, fee, charge, loss or any other amount payable to such Trustee under the applicable Trust Agreement (to the extent not previously reimbursed), shall be distributed to such Trustee, and (iii) each Certificateholder for payments, if any, made by it pursuant to Section 5.2 hereof in respect of amounts described in clause (i) above, shall be distributed to the applicable Trustee for the account of such Certificateholder, in each case, pro rata on the basis of all amounts described in clauses (i) through (iii) above;

third, such amount as shall be required to pay in full (i) first, unpaid PIK Amounts (applied first to interest and then principal) in respect of the Class A Certificates, and (ii) second, accrued and unpaid interest at the Stated Interest Rate on the Pool Balance of the Class A Certificates, shall be distributed to the Class A Trustee;

fourth, such amount as shall be required to pay (i) first, all unpaid PIK Amounts (applied first to interest and then principal) in respect of the Class B Certificates, and (ii) second, unpaid Class B Adjusted Interest, shall be distributed to the Class B Trustee;

fifth, such amount as shall be required to pay unpaid Class C Adjusted Interest (excluding commitment fees, if any, payable with respect to the Deposits) shall be distributed to the Class C Trustee;

sixth, such amount as shall be required to pay in full Expected Distributions to the holders of the Class A Certificates on such Distribution Date shall be distributed to the Class A Trustee;

seventh, such amount as shall be required to pay in full accrued and unpaid interest at the Stated Interest Rate on the Pool Balance of the Class B Certificates which was not previously paid pursuant to clause "fourth" above shall be distributed to the Class B Trustee;

eighth, such amount as shall be required to pay in full Expected Distributions to the holders of the Class B Certificates on such Distribution Date shall be distributed to the Class B Trustee;

ninth, such amount as shall be required to pay in full accrued and unpaid interest at the Stated Interest Rate on the Pool Balance of the Class C Certificates which was not previously paid pursuant to clause "fifth" above (excluding commitment fees, if any, payable with respect to the Deposits) shall be distributed to the Class C Trustee;

tenth, such amount as shall be required to pay in full Expected Distributions to the holders of the Class C Certificates on such Distribution Date shall be distributed to the Class C Trustee;

eleventh, the balance, if any, of any such amount remaining thereafter shall be held in the Collection Account for later distribution in accordance with this Article III.

With respect to clauses “first” and “second” above, no amounts shall be reimbursable to the Subordination Agent, any Trustee, or any Certificateholder for any payments made by any such Person in connection with any Equipment Note that is no longer held by the Subordination Agent (to the extent that such payments relate to periods after such Equipment Note ceases to be held by the Subordination Agent).

SECTION 3.3. Other Payments. (a) Any payments received by the Subordination Agent for which no provision as to the application thereof is made in this Agreement shall be distributed by the Subordination Agent (i) in the order of priority specified in Section 3.2 hereof and (ii) to the extent received or realized at any time after the Final Distributions for each Class of Certificates have been made, in the manner provided in clause “first” of Section 3.2 hereof.

(b) [Reserved].

(c) If the Subordination Agent receives any Scheduled Payment after the Scheduled Payment Date relating thereto, but prior to such payment becoming an Overdue Scheduled Payment, then the Subordination Agent shall deposit such Scheduled Payment in the Collection Account and promptly distribute such Scheduled Payment in accordance with the priority of distributions set forth in Section 3.2 hereof; provided that, for the purposes of this Section 3.3(c) only, each reference in clause “sixth,” “eighth” or “tenth” of Section 3.2 to “Distribution Date” shall be deemed to refer to such Scheduled Payment Date.

SECTION 3.4. Payments to the Trustees. Any amounts distributed hereunder by the Subordination Agent to any Trustee which shall not be the same institution as the Subordination Agent shall be paid to such Trustee by wire transfer to the account such Trustee shall provide to the Subordination Agent.

SECTION 3.5. [Reserved].

## ARTICLE IV

### EXERCISE OF REMEDIES

SECTION 4.1. Directions from the Controlling Party. (a) (i) Following the occurrence and during the continuation of an Indenture Default under any Indenture, the Controlling Party shall direct the Subordination Agent, as the holder of Equipment Notes issued under such Indenture, which in turn shall direct the Loan Trustee under such Indenture, in the exercise of remedies available to the holder of such Equipment Notes, including, without limitation, the ability to vote all such Equipment Notes held by the Subordination Agent in favor of Accelerating such Equipment Notes in accordance with the provisions of such Indenture. If the Equipment Notes issued pursuant to any Indenture and held by the Subordination Agent have been Accelerated following an Indenture Default with respect thereto, the Controlling Party may direct the Subordination Agent to sell, assign, contract to sell or otherwise dispose of and deliver all (but not less than all) of such Equipment Notes to any Person at public or private sale, at any location at the option of the Controlling Party, all upon such terms and conditions as it may reasonably deem advisable in accordance with applicable law.

(ii) Following the occurrence and during the continuation of an Indenture Default under any Indenture, in the exercise of remedies pursuant to such Indenture, the Loan Trustee under such Indenture may be directed to lease the related Aircraft to any Person (including Sun Country) so long as the Loan Trustee in doing so acts in a “commercially reasonable” manner within the meaning of Article 9 of the Uniform Commercial Code as in effect in any applicable jurisdiction (including Sections 9-610 and 9-627 thereof).

(iii) Notwithstanding the foregoing, so long as any Certificates remain Outstanding, during the period ending on the date which is nine months after the earlier of (x) the Acceleration of the Equipment Notes issued pursuant to any Indenture and (y) the occurrence of a Bankruptcy Event, without the consent of each Trustee, no Aircraft subject to the Lien of such Indenture or such Equipment Notes may be sold if the net proceeds from such sale would be less than the Minimum Sale Price for such Aircraft or such Equipment Notes.

(iv) Upon the occurrence and continuation of an Indenture Default under any Indenture, the Subordination Agent will obtain three desktop appraisals from the Appraisers selected by the Controlling Party setting forth the current market value, current lease rate and distressed value (in each case, as defined by the International Society of Transport Aircraft Trading or any successor organization) of the Aircraft subject to such Indenture (each such appraisal, an “Appraisal” and the current market value appraisals being referred to herein as the “Post-Default Appraisals”). For so long as any Indenture Default shall be continuing under any Indenture, and without limiting the right of the Controlling Party to request more frequent Appraisals, the Subordination Agent will obtain updated Appraisals on the date that is 364 days from the date of the most recent Appraisal (or if a Bankruptcy Event shall have occurred and is continuing, on the date that is 180 days from the date of the most recent Appraisal).

(b) Following the occurrence and during the continuance of an Indenture Default under any Indenture, the Controlling Party shall take such actions as it may reasonably deem most effectual to complete the sale or other disposition of the relevant Aircraft or Equipment Notes. In addition, in lieu of any sale, assignment, contract to sell or other disposition, the Controlling Party may maintain or cause the Subordination Agent to maintain possession of such Equipment Notes and continue to apply monies received in respect of such Equipment Notes in accordance with Article III hereof. In addition, in lieu of such sale, assignment, contract to sell or other disposition, or in lieu of such maintenance of possession, the Controlling Party may, subject to the terms and conditions of the related Indenture, instruct the Loan Trustee under such Indenture to foreclose on the Lien on the related Aircraft or to take any other remedial action permitted under such Indenture or under any applicable law.

(c) If following a Bankruptcy Event and during the pendency thereof, the Controlling Party receives a proposal from or on behalf of Sun Country to restructure the financing of any one or more of the Aircraft, the Controlling Party shall promptly thereafter give the Subordination Agent and each Trustee notice of the material economic terms and conditions of such restructuring proposal whereupon the Subordination Agent acting on behalf of each

Trustee shall endeavor using reasonable commercial efforts to make such terms and conditions of such restructuring proposal available to all Certificateholders. Thereafter, neither the Subordination Agent nor any Trustee, whether acting on instructions of the Controlling Party or otherwise, may, without the consent of each Trustee, enter into any term sheet, stipulation or other agreement (whether in the form of an adequate protection stipulation, an extension under Section 1110(b) of the Bankruptcy Code or otherwise) to effect any such restructuring proposal with or on behalf of Sun Country unless and until the material economic terms and conditions of such restructuring shall have been made available to all Certificateholders for a period of not less than 15 calendar days (except that such requirement shall not apply to any such term sheet, stipulation or other agreement that is entered into on or prior to the expiry of the 60-Day Period and that is effective for a period not longer than three months from the expiry of the 60-Day Period). In the event that any Class B Certificateholder, Class C Certificateholder or Additional Certificateholder gives irrevocable notice of the exercise of its right to purchase all (but not less than all) of the Class of Certificates represented by the then Controlling Party pursuant to the applicable Trust Agreement prior to the expiry of the 15-day notice period specified above, such Controlling Party may not direct the Subordination Agent or any Trustee to enter into any such restructuring proposal with respect to any of the Aircraft unless and until such Certificateholder shall fail to purchase such Class of Certificates on the date that it is required to make such purchase.

SECTION 4.2. Remedies Cumulative. Each and every right, power and remedy given to the Trustees, the Controlling Party or the Subordination Agent specifically or otherwise in this Agreement shall be cumulative and shall be in addition to every other right, power and remedy herein specifically given or now or hereafter existing at law, in equity or by statute, and each and every right, power and remedy whether specifically herein given or otherwise existing may, subject always to the terms and conditions hereof, be exercised from time to time and as often and in such order as may be deemed expedient by any Trustee, the Controlling Party or the Subordination Agent, as appropriate, and the exercise or the beginning of the exercise of any power or remedy shall not be construed to be a waiver of the right to exercise at the same time or thereafter any other right, power or remedy. No delay or omission by any Trustee, the Controlling Party or the Subordination Agent in the exercise of any right, remedy or power or in the pursuit of any remedy shall impair any such right, power or remedy or be construed to be a waiver of any default or to be an acquiescence therein.

SECTION 4.3. Discontinuance of Proceedings. In case any party to this Agreement (including the Controlling Party in such capacity) shall have instituted any Proceeding to enforce any right, power or remedy under this Agreement by foreclosure, entry or otherwise, and such Proceeding shall have been discontinued or abandoned for any reason or shall have been determined adversely to the Person instituting such Proceeding, then and in every such case each such party shall, subject to any determination in such Proceeding, be restored to its former position and rights hereunder, and all rights, remedies and powers of such party shall continue as if no such Proceeding had been instituted.

SECTION 4.4. Right of Certificateholders to Receive Payments Not to Be Impaired. Anything in this Agreement to the contrary notwithstanding but subject to each Trust Agreement, the right of any Certificateholder to receive payments hereunder (including without limitation pursuant to Section 3.2 hereof) when due, or to institute suit for the enforcement of any such payment on or after the applicable Distribution Date, shall not be impaired or affected without the consent of such Certificateholder.



SECTION 4.5. Undertaking for Costs. In any Proceeding for the enforcement of any right or remedy under this Agreement or in any Proceeding against any Controlling Party or the Subordination Agent for any action taken or omitted by it as Controlling Party or Subordination Agent, as the case may be, a court in its discretion may require the filing by any party litigant in the suit of an undertaking to pay the costs of the suit, and the court in its discretion may assess reasonable costs, including reasonable attorneys' fees and expenses, against any party litigant in the suit, having due regard to the merits and good faith of the claims or defenses made by the party litigant. The provisions of this Section do not apply to a suit instituted by the Subordination Agent or a Trustee or a suit by Certificateholders holding more than 10% of the original principal amount of any Class of Certificates.

## ARTICLE V

### DUTIES OF THE SUBORDINATION AGENT; AGREEMENTS OF TRUSTEES, ETC.

SECTION 5.1. Notice of Indenture Default or Triggering Event. (a) In the event the Subordination Agent shall have actual knowledge of the occurrence of an Indenture Default or a Triggering Event, as promptly as practicable, and in any event within 10 days after obtaining knowledge thereof, the Subordination Agent shall transmit by mail or courier to each Rating Agency and the Trustees notice of such Indenture Default or Triggering Event, unless such Indenture Default or Triggering Event shall have been cured or waived. For all purposes of this Agreement, in the absence of actual knowledge on the part of a Responsible Officer, the Subordination Agent shall not be deemed to have knowledge of any Indenture Default or Triggering Event unless notified in writing by one or more Trustees, or one or more Certificateholders.

(b) Other Notices. The Subordination Agent will furnish to each Trustee, promptly upon receipt thereof, duplicates or copies of all reports, notices, requests, demands, certificates, financial statements and other instruments furnished to the Subordination Agent as registered holder of the Equipment Notes or otherwise in its capacity as Subordination Agent to the extent the same shall not have been otherwise directly distributed to such Trustee, pursuant to the express provision of any other Operative Agreement.

(c) Securities Position. Upon the occurrence of an Indenture Default, the Subordination Agent shall instruct the Trustees to, and the Trustees shall, make available to all Certificateholders a securities position listing setting forth the names of all the parties reflected in its records as holding interests in the Certificates.

(d) Reports. Promptly after the occurrence of a Triggering Event or an Indenture Default resulting from the failure of Sun Country to make payments on any Equipment Note and on every Regular Distribution Date while the Triggering Event or such Indenture Default shall be continuing, the Subordination Agent will provide to the Trustee, each Rating Agency and Sun Country a statement setting forth the following information:

(i) after a Bankruptcy Event, with respect to each Aircraft, whether such Aircraft is (A) subject to the 60-day period of Section 1110(a)(2)(A) of the Bankruptcy Code, (B) subject to an election by Sun Country under Section 1110(a) of the Bankruptcy Code, (C) covered by an agreement contemplated by Section 1110(b) of the Bankruptcy Code or (D) not subject to any of (A), (B) or (C);

(ii) to the best of the Subordination Agent's knowledge, after requesting such information from Sun Country, (A) whether the Aircraft are currently in service or parked in storage, (B) the maintenance status of the Aircraft and (C) the location of the Engines (as defined in the Indentures);

(iii) the current Pool Balance of the Certificates, the Preferred B Pool Balance, the Preferred C Pool Balance and the outstanding principal amount of all Equipment Notes;

(iv) the expected amount of interest which will have accrued on the Equipment Notes and on the Certificates as of the next Regular Distribution Date, and, as to the Certificates, the applicable PIK Amounts (including current principal amount and expected amount of interest which will have accrued thereon as of the next Regular Distribution Date);

(v) the amounts paid to each Person on such Distribution Date pursuant to this Agreement;

(vi) details of the amounts paid on such Distribution Date identified by reference to the relevant provision of this Agreement and the source of payment (by Aircraft and party); and

(vii) after a Bankruptcy Event, any operational reports filed by Sun Country with the bankruptcy court which are available to the Subordination Agent on a non-confidential basis.

SECTION 5.2. Indemnification. The Subordination Agent shall not be required to take any action or refrain from taking any action under Section 5.1 (other than the first sentence thereof) or Article IV hereof unless the Subordination Agent shall have been indemnified (to the extent and in the manner reasonably satisfactory to the Subordination Agent) against any liability, cost or expense (including counsel fees and expenses) which may be incurred in connection therewith. The Subordination Agent shall not be under any obligation to take any action under this Agreement and nothing contained in this Agreement shall require the Subordination Agent to expend or risk its own funds or otherwise incur any financial liability in the performance of any of its duties hereunder or in the exercise of any of its rights or powers if it shall have reasonable grounds for believing that repayment of such funds or adequate indemnity against such risk or liability is not reasonably assured to it. The Subordination Agent shall not be required to take any action under Section 5.1 (other than the first sentence thereof) or Article IV hereof, nor shall any other provision of this Agreement be deemed to impose a duty on the Subordination Agent to take any action, if the Subordination Agent shall have been advised by counsel that such action is contrary to the terms hereof or is otherwise contrary to law.

SECTION 5.3. No Duties Except as Specified in this Intercreditor Agreement. The Subordination Agent shall not have any duty or obligation to take or refrain from taking any action under, or in connection with, this Agreement, except as expressly provided by the terms of this Agreement; and no implied duties or obligations shall be read into this Agreement against the Subordination Agent. The Subordination Agent agrees that it will, in its individual capacity and at its own cost and expense (but without any right of indemnity in respect of any such cost or expense under Section 5.2 or 7.1 hereof) promptly take such action as may be necessary to duly discharge all Liens on any of the Trust Accounts or any monies deposited therein which result from claims against it in its individual capacity not related to its activities hereunder or any other Operative Agreement.

SECTION 5.4. Notice from the Trustees. If any Trustee has notice of an Indenture Default or a Triggering Event, such Person shall promptly give notice thereof to each other party hereto, provided, however, that no such Person shall have any liability hereunder as a result of its failure to deliver any such notice.

## ARTICLE VI

### THE SUBORDINATION AGENT

SECTION 6.1. Authorization; Acceptance of Trusts and Duties. Each of the Trustees hereby designates and appoints the Subordination Agent as the Subordination Agent under this Agreement. WTNA hereby accepts the duties hereby created and applicable to it as the Subordination Agent and agrees to perform the same but only upon the terms of this Agreement and agrees to receive and disburse all monies received by it in accordance with the terms hereof. The Subordination Agent shall not be answerable or accountable under any circumstances, except (a) for its own willful misconduct or gross negligence (or ordinary negligence in the handling of funds), (b) as provided in Sections 2.2 or 5.3 hereof and (c) for liabilities that may result from the material inaccuracy of any representation or warranty of the Subordination Agent made in its individual capacity in any Operative Agreement. The Subordination Agent shall not be liable for any error of judgment made in good faith by a Responsible Officer of the Subordination Agent, unless it is proved that the Subordination Agent was negligent in ascertaining the pertinent facts.

SECTION 6.2. Absence of Duties. The Subordination Agent shall have no duty to see to any recording or filing of this Agreement or any other document, or to see to the maintenance of any such recording or filing.

SECTION 6.3. No Representations or Warranties as to Documents. The Subordination Agent in its individual capacity does not make nor shall be deemed to have made any representation or warranty as to the validity, legality or enforceability of this Agreement or any other Operative Agreement or as to the correctness of any statement contained in any thereof, except for the representations and warranties of the Subordination Agent, made in its individual capacity, under any Operative Agreement to which it is a party. The Certificateholders and the Trustees make no representation or warranty hereunder whatsoever.

SECTION 6.4. No Segregation of Monies; No Interest. Any monies paid to or retained by the Subordination Agent pursuant to any provision hereof and not then required to be distributed to any Trustee as provided in Articles II and III hereof or deposited into one or more Trust Accounts need not be segregated in any manner except to the extent required by such Articles II and III and by law, and the Subordination Agent shall not (except as otherwise provided in Section 2.2 hereof) be liable for any interest thereon; provided, however, that any payments received or applied hereunder by the Subordination Agent shall be accounted for by the Subordination Agent so that any portion thereof paid or applied pursuant hereto shall be identifiable as to the source thereof.

SECTION 6.5. Reliance; Agents; Advice of Counsel. The Subordination Agent shall not incur liability to anyone in acting upon any signature, instrument, notice, resolution, request, consent, order, certificate, report, opinion, bond or other document or paper believed by it to be genuine and believed by it to be signed by the proper party or parties. As to the Pool Balance of any Trust as of any date, the Subordination Agent may for all purposes hereof rely on a certificate signed by any Responsible Officer of the applicable Trustee, and such certificate shall constitute full protection to the Subordination Agent for any action taken or omitted to be taken by it in good faith in reliance thereon. As to any fact or matter relating to the Trustees the manner of ascertainment of which is not specifically described herein, the Subordination Agent may for all purposes hereof rely on a certificate, signed by any Responsible Officer of the applicable Trustee as to such fact or matter, and such certificate shall constitute full protection to the Subordination Agent for any action taken or omitted to be taken by it in good faith in reliance thereon. The Subordination Agent shall assume, and shall be fully protected in assuming, that each of the Trustees are authorized to enter into this Agreement and to take all action to be taken by them pursuant to the provisions hereof, and shall not inquire into the authorization of the Trustees with respect thereto. In the administration of the trusts hereunder, the Subordination Agent may execute any of the trusts or powers hereof and perform its powers and duties hereunder directly or through agents or attorneys and may consult with counsel, accountants and other skilled persons to be selected and retained by it, and the Subordination Agent shall not be liable for the acts or omissions of any agent appointed with due care or for anything done, suffered or omitted in good faith by it in accordance with the advice or written opinion of any such counsel, accountants or other skilled persons.

SECTION 6.6. Capacity in Which Acting. The Subordination Agent acts hereunder solely as agent and trustee herein and not in its individual capacity, except as otherwise expressly provided in the Operative Agreements.

SECTION 6.7. Compensation. The Subordination Agent shall be entitled to reasonable compensation, including expenses and disbursements, for all services rendered hereunder and shall have a priority claim to the extent set forth in Article III hereof on all monies collected hereunder for the payment of such compensation, to the extent that such compensation shall not be paid by others. The Subordination Agent agrees that it shall have no right against any Trustee for any fee as compensation for its services as agent under this Agreement. The provisions of this Section 6.7 shall survive the termination of this Agreement.

SECTION 6.8. May Become Certificateholder. The institution acting as Subordination Agent hereunder may become a Certificateholder and have all rights and benefits of a Certificateholder to the same extent as if it were not the institution acting as the Subordination Agent.

SECTION 6.9. Subordination Agent Required; Eligibility. There shall at all times be a Subordination Agent hereunder which shall be a corporation or national banking association organized and doing business under the laws of the United States of America or of any State or the District of Columbia having a combined capital and surplus of at least \$100,000,000 (or the obligations of which, whether now in existence or hereafter incurred, are fully and unconditionally guaranteed by a corporation or national banking association organized and doing business under the laws of the United States of America, any State thereof or of the District of Columbia and having a combined capital and surplus of at least \$100,000,000), if there is such an institution willing and able to perform the duties of the Subordination Agent hereunder upon reasonable or customary terms. Such corporation or national banking association shall be a citizen of the United States and shall be authorized under the laws of the United States or any State thereof or of the District of Columbia to exercise corporate trust powers and shall be subject to supervision or examination by federal, state or District of Columbia authorities. If such corporation or national banking association publishes reports of condition at least annually, pursuant to law or to the requirements of any of the aforesaid supervising or examining authorities, then, for the purposes of this Section 6.9, the combined capital and surplus of such corporation or national banking association shall be deemed to be its combined capital and surplus as set forth in its most recent report of condition so published.

In case at any time the Subordination Agent shall cease to be eligible in accordance with the provisions of this Section, the Subordination Agent shall resign immediately in the manner and with the effect specified in Section 8.1.

SECTION 6.10. Money to Be Held in Trust. All Equipment Notes, monies and other property deposited with or held by the Subordination Agent pursuant to this Agreement shall be held in trust for the benefit of the parties entitled to such Equipment Notes, monies and other property. All such Equipment Notes, monies or other property shall be held in the trust department of the institution acting as Subordination Agent hereunder.

SECTION 6.11. Notice of Substitution of Airframe. If the Subordination Agent, in its capacity as a holder of Equipment Notes issued under an Indenture, receives a notice of substitution of a Substitute Airframe (as defined in such Indenture) pursuant to Section 4.04(f) of such Indenture, the Subordination Agent shall promptly (i) provide a copy of such notice to each Trustee and each Rating Agency and (ii) on behalf of each Trustee make available such notice to all Certificateholders.

## ARTICLE VII

### INDEMNIFICATION OF SUBORDINATION AGENT

SECTION 7.1. Scope of Indemnification. The Subordination Agent shall be indemnified hereunder to the extent and in the manner described in Section 8.1 of the Participation Agreements and Section 6 of the Note Purchase Agreement. The indemnities contained in such Sections of such agreements shall survive the termination of this Agreement.

ARTICLE VIII

SUCCESSOR SUBORDINATION AGENT

SECTION 8.1. Replacement of Subordination Agent; Appointment of Successor. The Subordination Agent may resign at any time by so notifying each other party hereto. The Controlling Party may remove the Subordination Agent for cause by so notifying the Subordination Agent and may appoint a successor Subordination Agent. The Controlling Party shall remove the Subordination Agent if:

- (1) the Subordination Agent fails to comply with Section 6.9 hereof;
- (2) the Subordination Agent is adjudged bankrupt or insolvent;
- (3) a receiver or other public officer takes charge of the Subordination Agent or its property; or
- (4) the Subordination Agent otherwise becomes incapable of acting.

If the Subordination Agent resigns or is removed or if a vacancy exists in the office of Subordination Agent for any reason (the Subordination Agent in such event being referred to herein as the retiring Subordination Agent), the Controlling Party shall promptly appoint a successor Subordination Agent.

A successor Subordination Agent shall deliver (x) a written acceptance of its appointment as Subordination Agent hereunder to the retiring Subordination Agent and (y) a written assumption of its obligations hereunder to each party hereto, upon which the resignation or removal of the retiring Subordination Agent shall become effective, and the successor Subordination Agent shall have all the rights, powers and duties of the Subordination Agent under this Agreement. The successor Subordination Agent shall mail a notice of its succession to each other party hereto. The retiring Subordination Agent shall promptly transfer its rights to all of the property held by it as Subordination Agent to the successor Subordination Agent.

If a successor Subordination Agent does not take office within 60 days after the retiring Subordination Agent resigns or is removed, the retiring Subordination Agent or one or more of the Trustees may petition any court of competent jurisdiction for the appointment of a successor Subordination Agent.

If the Subordination Agent fails to comply with Section 6.9 hereof (to the extent applicable), one or more of the Trustees may petition any court of competent jurisdiction for the removal of the Subordination Agent and the appointment of a successor Subordination Agent.

Notwithstanding the foregoing, no resignation or removal of the Subordination Agent shall be effective unless and until a successor has been appointed. If any Class of Certificates is then rated, no appointment of a successor Subordination Agent shall be effective unless and until each Rating Agency shall have delivered a Ratings Confirmation.

## SUPPLEMENTS AND AMENDMENTS

SECTION 9.1. Amendments, Waivers, Possible Future Issuance of an Additional Class of Certificates, etc. (a) This Agreement may not be supplemented, amended or modified without the consent of each Trustee (acting, except in the case of any amendment contemplated by the last sentence of this Section 9.1(a), with the consent of holders of Certificates of the related Class evidencing interests in the related Trust aggregating not less than a majority in interest in such Trust or as otherwise authorized pursuant to the relevant Trust Agreement), and the Subordination Agent; provided, however, that this Agreement may be supplemented, amended or modified without the consent of any Trustee if such supplement, amendment or modification (i) is in accordance with Section 9.1(c) or Section 9.1(d) hereof or (ii) cures an ambiguity or inconsistency or does not materially adversely affect such Trustee or the holders of the related Class of Certificates; provided further, however, that, if such supplement, amendment or modification (A) would (x) directly or indirectly modify or supersede, or otherwise conflict with, Section 2.2(b), the last sentence of this Section 9.1(a), Section 9.1(c), Section 9.1(d), the second sentence of Section 10.6 or this proviso (collectively, the “Sun Country Provisions”) or (y) otherwise adversely affect the interests of Sun Country with respect to its payment obligations under any Operative Agreement, or (B) is made pursuant to the last sentence of this Section 9.1(a) or pursuant to Section 9.1(c) or Section 9.1(d), then such supplement, amendment or modification shall not be effective without the additional written consent of Sun Country. Notwithstanding the foregoing, without the consent of each Certificateholder, no supplement, amendment or modification of this Agreement may (i) reduce the percentage of the interest in any Trust evidenced by the Certificates issued by such Trust necessary to consent to modify or amend any provision of this Agreement or to waive compliance therewith or (ii) except as provided in this Section 9.1(a), Section 9.1(c) or Section 9.1(d), modify Section 2.4 or 3.2 hereof, relating to the distribution of monies received by the Subordination Agent hereunder from the Equipment Notes. Nothing contained in this Section shall require the consent of a Trustee at any time following the payment of Final Distributions with respect to the related Class of Certificates.

(b) In the event that the Subordination Agent, as the registered holder of any Equipment Notes, receives a request for the giving of any notice or for its consent to any amendment, supplement, modification, consent or waiver under such Equipment Notes, the Indenture pursuant to which such Equipment Notes were issued, or the related Participation Agreement or other related document, (i) if no Indenture Default shall have occurred and be continuing with respect to such Indenture, the Subordination Agent shall request directions with respect to each Series of such Equipment Notes from the Trustee of the Trust which holds such Equipment Notes and shall vote or consent in accordance with the directions of such Trustee, and (ii) if any Indenture Default shall have occurred and be continuing with respect to such Indenture, the Subordination Agent will exercise its voting rights with respect to such Equipment Notes as directed by the Controlling Party (subject to Sections 4.1 and 4.4 hereof); provided that no such amendment, supplement, modification, consent or waiver shall, without the consent of each affected Certificateholder, reduce the amount of principal or interest payable by Sun Country under any Equipment Note or change the time of payment or method of calculation of any amount under any Equipment Note.

(c) If the Series B Equipment Notes or the Series C Equipment Notes issued with respect to all of the Aircraft are repaid and re-issued in accordance with the terms of Section 4(a)(vi) of the Note Purchase Agreement, or any series of Additional Equipment Notes issued pursuant to Section 9.1(d) are repaid and re-issued in accordance with Section 4(a)(vi) of the Note Purchase Agreement, such series of re-issued Equipment Notes (the “Refinancing Equipment Notes”) shall be issued to a new pass through trust (a “Refinancing Trust”) that issues a class of pass through certificates (the “Refinancing Certificates”) to certificateholders (the “Refinancing Certificateholders”) pursuant to a pass through trust agreement (a “Refinancing Trust Agreement”) with a trustee (a “Refinancing Trustee”). A Refinancing Trust, a Refinancing Trustee and the Refinancing Certificates shall be subject to all of the provisions of this Agreement in the same manner as the Class B Trust, the Class C Trust or the applicable Additional Trust, the Class B Trustee, the Class C Trustee or the applicable Additional Trustee and the Class B Certificates, the Class C Certificates or the applicable Additional Certificates, whichever corresponds to the series of the refinanced Equipment Notes, including the subordination of the Refinancing Certificates to the Administration Expenses, and the Class A Certificates and, if applicable, the Class B Certificates and, if applicable, the Class C Certificates and, if applicable, any previously issued class of Additional Certificates. Such issuance of Refinancing Equipment Notes and Refinancing Certificates and the amendment of this Agreement as provided below shall require Ratings Confirmation (if any Class is then rated) and shall not materially adversely affect any of the Trustees. This Agreement shall be amended by written agreement of Sun Country and the Subordination Agent to give effect to the issuance of any Refinancing Certificates subject to the following terms and conditions:

(i) the Refinancing Trustee shall be added as a party to this Agreement;

(ii) the definitions of “Certificate”, “Class”, “Class B Certificates” (if applicable), “Class C Certificates” (if applicable), “Final Legal Distribution Date”, “Trust”, “Trust Agreement” and “Controlling Party” (and such other applicable definitions) shall be revised, as appropriate, to reflect such issuance (and the subordination of the Refinancing Certificates and the Refinancing Equipment Notes);

(iii) the Refinancing Certificates may be rated by one or more Rating Agencies, and may allow for payment in kind of interest in a manner similar to the PIK Amounts;

(iv) the Refinancing Certificates cannot be issued to Sun Country but may be issued to any of Sun Country’s Affiliates so long as such Affiliate shall have bankruptcy remote and special purpose provisions in its certificate of incorporation or other organizational documents and any subsequent transfer of the Refinancing Certificates to any Affiliate of Sun Country shall be similarly restricted; and

(v) the scheduled payment dates on the Refinancing Equipment Notes shall be on the Regular Distribution Dates.

The issuance of the Refinancing Certificates in compliance with all of the foregoing terms of this Section 9.1(c) shall not require the consent of any of the Trustees or the holders of any Class of Certificates.



(d) Pursuant to the terms of Section 2.02 of each Indenture and Section 4(a)(vi) of the Note Purchase Agreement, one or more additional series of Equipment Notes (the “Additional Equipment Notes”), which shall be subordinated in right of payment to the Series A Equipment Notes, the Series B Equipment Notes and the Series C Equipment Notes under such Indenture, may be issued at any time, and from time to time, on or after the final Closing Date. If any series of Additional Equipment Notes are issued under one or more of the Indentures, each such series of Additional Equipment Notes shall be issued to a new pass through trust (an “Additional Trust”) that issues a class of pass through certificates (the “Additional Certificates”) to certificateholders (the “Additional Certificateholders”) pursuant to a pass through trust agreement (an “Additional Trust Agreement”) with a trustee (an “Additional Trustee”). In such case, this Agreement shall be amended by written agreement of Sun Country and the Subordination Agent to provide for the subordination of the Additional Certificates to the Administration Expenses, the Class A Certificates, the Class B Certificates, the Class C Certificates and, if applicable, any previously issued class of Additional Certificates (subject to clause (iii) below). Such issuance and the amendment of this Agreement as provided below shall require Ratings Confirmation (if applicable) and shall not materially adversely affect any of the Trustees. This Agreement shall be amended by written agreement of Sun Country and the Subordination Agent to give effect to the issuance of any Additional Certificates subject to the following terms and conditions:

(i) the Additional Trustee shall be added as a party to this Agreement;

(ii) the definitions of “Certificate”, “Class”, “Equipment Notes”, “Final Legal Distribution Date”, “Trust”, “Trust Agreement” and “Controlling Party” (and such other applicable definitions) shall be revised, as appropriate, to reflect the issuance of the Additional Certificates (and the subordination thereof);

(iii) Section 3.2 may be revised to provide for the distribution of “PIK Amounts” (calculated in a manner similar to the calculation of PIK Amounts for the Class B Certificates) and “Adjusted Interest” (calculated in a manner substantially similar to the calculation of Class C Adjusted Interest) for such class of Additional Certificates after the Class C Adjusted Interest (and, if applicable, after any “Adjusted Interest” for any previously issued class of Additional Certificates) but before Expected Distributions on the Class A Certificates;

(iv) the Additional Certificates may be rated by one or more Rating Agencies;

(v) the Additional Certificates may allow for payment in kind of interest as “PIK Amounts” in a manner similar to the PIK Amounts in respect of the Class B Certificates;

(vi) the Additional Certificates cannot be issued to Sun Country but may be issued to any of Sun Country’s Affiliates so long as such Affiliate shall have bankruptcy remote and special purpose provisions in its certificate of incorporation or other organizational documents and any subsequent transfer of the Additional Certificates to any Affiliate of Sun Country shall be similarly restricted;

(vii) the provisions of this Agreement governing payments with respect to Certificates and related notices, including Sections 2.4, 3.1 and 3.2, shall be revised to provide for distributions on such class of the Additional Certificates after payment of Administration Expenses, the Class A Certificates, the Class B Certificates and the Class C Certificates (and, if applicable, any previously issued class of Additional Certificates), subject to clause (iii) above; and

(viii) the scheduled payment dates on such series of Additional Equipment Notes shall be on the Regular Distribution Dates.

The issuance of the Additional Certificates in compliance with all of the foregoing terms of this Section 9.1(d) shall not require the consent of any of the Trustees or the holders of any Class of Certificates.

SECTION 9.2. Subordination Agent Protected. If, in the reasonable opinion of the institution acting as the Subordination Agent hereunder, any document required to be executed pursuant to the terms of Section 9.1 affects any right, duty, immunity or indemnity with respect to it under this Agreement, the Subordination Agent may in its discretion decline to execute such document.

SECTION 9.3. Effect of Supplemental Agreements. Upon the execution of any amendment, consent or supplement hereto pursuant to the provisions hereof, this Agreement shall be and be deemed to be and shall be modified and amended in accordance therewith and the respective rights, limitations of rights, obligations, duties and immunities under this Agreement of the parties hereto and beneficiaries hereof shall thereafter be determined, exercised and enforced hereunder subject in all respects to such modifications and amendments, and all the terms and conditions of any such amendment, consent or supplement shall be and be deemed to be and shall be part of the terms and conditions of this Agreement for any and all purposes. In executing or accepting any amendment, consent or supplement permitted by this Article IX, the Subordination Agent shall be entitled to receive, and shall be fully protected in relying upon, an opinion of counsel stating that the execution of such amendment, consent or supplement is authorized or permitted by this Agreement.

SECTION 9.4. Notice to Rating Agency. Promptly upon receipt of any amendment, consent, modification, supplement or waiver contemplated by this Article IX and prior to taking any action required to be taken thereunder, the Subordination Agent shall send a copy thereof to each Rating Agency.

## ARTICLE X

### MISCELLANEOUS

SECTION 10.1. Termination of Intercreditor Agreement. Following payment of Final Distributions with respect to each Class of Certificates and provided that there shall then be no other amounts due to the Certificateholders, the Trustees and the Subordination Agent hereunder or under the Trust Agreements, this Agreement and the trusts created hereby shall terminate and this Agreement shall be of no further force or effect. Except as aforesaid or otherwise provided, this Agreement and the trusts created hereby shall continue in full force and effect in accordance with the terms hereof.

SECTION 10.2. Intercreditor Agreement for Benefit of Trustees and Subordination Agent. Subject to the second sentence of Section 10.6 and the provisions of Sections 4.4 and 9.1, nothing in this Agreement, whether express or implied, shall be construed to give to any Person other than the Trustees and the Subordination Agent any legal or equitable right, remedy or claim under or in respect of this Agreement.

SECTION 10.3. Notices. Unless otherwise expressly specified or permitted by the terms hereof, all notices, requests, demands, authorizations, directions, consents, waivers or documents provided or permitted by this Agreement to be made, given, furnished or filed shall be in writing, mailed by certified mail, postage prepaid, or by confirmed telecopy and

(i) if to the Subordination Agent, addressed to at its office at:

Wilmington Trust, National Association  
1100 N. Market Street  
Wilmington, DE 19890-1605  
Attention: Corporate Trust Administration  
Telecopy: (302) 636-4140

(ii) if to any Trustee, addressed to it at its office at:

Wilmington Trust, National Association  
1100 N. Market Street  
Wilmington, DE 19890-1605  
Attention: Corporate Trust Administration  
Telecopy: (302) 636-4140.

Whenever any notice in writing is required to be given by any Trustee or the Subordination Agent to any of the other of them, such notice shall be deemed given and such requirement satisfied when such notice is received. Any party hereto may change the address to which notices to such party will be sent by giving notice of such change to the other parties to this Agreement.

SECTION 10.4. Severability. Any provision of this Agreement which is prohibited or unenforceable in any jurisdiction shall, as to such jurisdiction, be ineffective to the extent of such prohibition or unenforceability without invalidating the remaining provisions hereof, and any such prohibition or unenforceability in any jurisdiction shall not invalidate or render unenforceable such provision in any other jurisdiction.

SECTION 10.5. No Oral Modifications or Continuing Waivers. No terms or provisions of this Agreement may be changed, waived, discharged or terminated orally, but only by an instrument in writing signed by the party or other Person against whom enforcement of the change, waiver, discharge or termination is sought and any other party or other Person whose consent is required pursuant to this Agreement and any waiver of the terms hereof shall be effective only in the specific instance and for the specific purpose given.

SECTION 10.6. Successors and Assigns. All covenants and agreements contained herein shall be binding upon, and inure to the benefit of, each of the parties hereto and the successors and assigns of each, all as herein provided. In addition, the Sun Country Provisions shall inure to the benefit of Sun Country and its successors and assigns, and (without limitation of the foregoing) Sun Country is hereby constituted, and agreed to be, an express third party beneficiary of the Sun Country Provisions.

SECTION 10.7. Headings. The headings of the various Articles and Sections herein and in the table of contents hereto are for convenience of reference only and shall not define or limit any of the terms or provisions hereof.

SECTION 10.8. Counterpart Form. This Agreement may be executed by the parties hereto in separate counterparts, each of which when so executed and delivered shall be an original, but all such counterparts shall together constitute but one and the same agreement.

SECTION 10.9. Subordination. (a) If any Trustee or the Subordination Agent receives any payment in respect of any obligations owing hereunder, which is subsequently invalidated, declared preferential, set aside and/or required to be repaid to a trustee, receiver or other party, then, to the extent of such payment, such obligations intended to be satisfied shall be revived and continue in full force and effect as if such payment had not been received.

(b) Each of the Trustees (on behalf of themselves and the holders of the Certificates) and the Subordination Agent may take any of the following actions without impairing their rights under this Agreement:

- (i) obtain a Lien on any property to secure any amounts owing to it hereunder,
- (ii) obtain the primary or secondary obligation of any other obligor with respect to any amounts owing to it hereunder,
- (iii) renew, extend, increase, alter or exchange any amounts owing to it hereunder, or release or compromise any obligation of any obligor with respect thereto,
- (iv) refrain from exercising any right or remedy, or delay in exercising such right or remedy, which it may have, or
- (v) take any other action which might discharge a subordinated party or a surety under applicable law;

provided, however, that the taking of any such actions by any of the Trustees or the Subordination Agent shall not prejudice the rights or adversely affect the obligations of any other party under this Agreement.

SECTION 10.10. Governing Law. THIS AGREEMENT SHALL IN ALL RESPECTS BE GOVERNED BY, AND CONSTRUED IN ACCORDANCE WITH, THE LAW OF THE STATE OF NEW YORK, INCLUDING ALL MATTERS OF CONSTRUCTION, VALIDITY AND PERFORMANCE.

SECTION 10.11. Submission to Jurisdiction; Waiver of Jury Trial; Waiver of Immunity.

(a) Each of the parties hereto hereby irrevocably and unconditionally:

(i) submits for itself and its property in any legal action or proceeding relating to this Agreement or any other Operative Agreement, or for recognition and enforcement of any judgment in respect hereof or thereof, to the nonexclusive general jurisdiction of the courts of the State of New York, the courts of the United States of America for the Southern District of New York, and the appellate courts from any thereof;

(ii) consents that any such action or proceeding may be brought in such courts, and waives any objection that it may now or hereafter have to the venue of any such action or proceeding in any such court or that such action or proceeding was brought in an inconvenient court and agrees not to plead or claim the same;

(iii) agrees that service of process in any such action or proceeding may be effected by mailing a copy thereof by registered or certified mail (or any substantially similar form of mail), postage prepaid, to each party hereto at its address set forth in Section 10.3 hereof, or at such other address of which the other parties shall have been notified pursuant thereto; and

(iv) agrees that nothing herein shall affect the right to effect service of process in any other manner permitted by law or shall limit the right to sue in any other jurisdiction.

(b) EACH OF THE PARTIES HERETO HEREBY AGREES TO WAIVE ITS RESPECTIVE RIGHTS TO A JURY TRIAL OF ANY CLAIM OR CAUSE OF ACTION BASED UPON OR ARISING OUT OF THIS AGREEMENT OR ANY DEALINGS BETWEEN THEM RELATING TO THE SUBJECT MATTER OF THIS AGREEMENT AND THE RELATIONSHIP THAT IS BEING ESTABLISHED, including, without limitation, contract claims, tort claims, breach of duty claims and all other common law and statutory claims. Each of the parties warrants and represents that it has reviewed this waiver with its legal counsel, and that it knowingly and voluntarily waives its jury trial rights following consultation with such legal counsel. THIS WAIVER IS IRREVOCABLE, AND CANNOT BE MODIFIED EITHER ORALLY OR IN WRITING, AND THIS WAIVER SHALL APPLY TO ANY SUBSEQUENT AMENDMENTS, RENEWALS, SUPPLEMENTS OR MODIFICATIONS TO THIS AGREEMENT.

IN WITNESS WHEREOF, the parties hereto have caused this Agreement to be duly executed by their respective officers thereunto duly authorized, as of the day and year first above written, and acknowledge that this Agreement has been made and delivered in the City of New York, and this Agreement has become effective only upon such execution and delivery.

WILMINGTON TRUST, NATIONAL ASSOCIATION,  
not in its individual capacity but solely as Trustee for each of  
the Trusts

By /s/ Chad May

Name: Chad May

Title: Vice President

WILMINGTON TRUST, NATIONAL ASSOCIATION,  
not in its individual capacity except as expressly set forth  
herein but solely as Subordination Agent and Trustee

By /s/ Chad May

Name: Chad May

Title: Vice President

**ASSET-BASED REVOLVING CREDIT AGREEMENT**

Dated as of December 13, 2017,

Among

SCA ACQUISITION, LLC,

as Holdings,

MN AIRLINES, LLC,

as the Borrower (from and after the Closing Date),

THE LENDERS PARTY HERETO,

BARCLAYS BANK PLC,

as Administrative Agent and Collateral Agent

---

BARCLAYS BANK PLC,  
as Lead Arranger, Bookrunner, and Syndication Agent

---

## TABLE OF CONTENTS

	Page
ARTICLE I Definitions	1
Section 1.01 Defined Terms	1
Section 1.02 Terms Generally	64
Section 1.03 Exchange Rates; Currency Equivalents	64
Section 1.04 Timing of Payment or Performance	64
Section 1.05 Times of Day	65
ARTICLE II The Credits	65
Section 2.01 Commitments	65
Section 2.02 Loans and Borrowings	66
Section 2.03 Requests for Borrowings	67
Section 2.04 Swingline Loans	68
Section 2.05 Letters of Credit	71
Section 2.06 Funding of Borrowings	77
Section 2.07 Interest Elections	78
Section 2.08 Termination and Reduction of Commitments	79
Section 2.09 Repayment of Loans; Evidence of Debt	80
Section 2.10 Notice of Prepayment of Revolving Loans	81
Section 2.11 Prepayment of Loans	81
Section 2.12 Fees	81
Section 2.13 Interest	82
Section 2.14 Alternate Rate of Interest	83
Section 2.15 Increased Costs	84
Section 2.16 Break Funding Payments	85
Section 2.17 Taxes	85
Section 2.18 Payments Generally; Pro Rata Treatment; Sharing of Set-offs	90
Section 2.19 Mitigation Obligations; Replacement of Lenders	92
Section 2.20 Illegality	93
Section 2.21 Incremental Commitments	93
Section 2.22 Defaulting Lender	96
ARTICLE III Representations and Warranties	99
Section 3.01 Organization; Powers	99
Section 3.02 Authorization	99
Section 3.03 Enforceability	100
Section 3.04 Governmental Approvals	100
Section 3.05 Financial Statements	100
Section 3.06 No Material Adverse Effect	100
Section 3.07 Title to Properties; Possession Under Leases	100
Section 3.08 Subsidiaries	101
Section 3.09 Litigation; Compliance with Laws	101
Section 3.10 Federal Reserve Regulations	102
Section 3.11 Investment Company Act	102
Section 3.12 Use of Proceeds	102



Section 3.13	Tax Returns	102
Section 3.14	No Material Misstatements	103
Section 3.15	Employee Benefit Plans	103
Section 3.16	Environmental Matters	103
Section 3.17	Security Documents	104
Section 3.18	Location of Real Property	105
Section 3.19	Solvency	105
Section 3.20	Labor Matters	106
Section 3.21	Insurance	106
Section 3.22	No Default	106
Section 3.23	Intellectual Property; Licenses, Etc.	106
Section 3.24	Senior Debt	107
Section 3.25	USA PATRIOT Act; OFAC	107
Section 3.26	Foreign Corrupt Practices Act	107
ARTICLE IV	Conditions of Lending	108
Section 4.01	Conditions Precedent to Credit Events After the Closing Date	108
Section 4.02	Conditions Precedent to the Effective Date	108
Section 4.03	Conditions Precedent to the Closing Date	109
ARTICLE V	Affirmative Covenants	112
Section 5.01	Existence; Business and Properties	112
Section 5.02	Insurance	113
Section 5.03	Taxes	114
Section 5.04	Financial Statements, Reports, etc.	114
Section 5.05	Litigation and Other Notices	117
Section 5.06	Compliance with Laws	118
Section 5.07	Maintaining Records; Access to Properties and Inspections; Collateral Audits; Appraisals	118
Section 5.08	Use of Proceeds	119
Section 5.09	Compliance with Environmental Laws	120
Section 5.10	Further Assurances; Additional Security	120
Section 5.11	Cash Management Systems; Application of Proceeds of Accounts	123
Section 5.12	Post-Closing	125
ARTICLE VI	Negative Covenants	125
Section 6.01	Indebtedness	125
Section 6.02	Liens	129
Section 6.03	Sale and Lease-Back Transactions	135
Section 6.04	Investments, Loans and Advances	135
Section 6.05	Mergers, Consolidations, Sales of Assets and Acquisitions	140
Section 6.06	Dividends and Distributions	143
Section 6.07	Transactions with Affiliates	145
Section 6.08	Business of the Borrower and the Subsidiaries	148
Section 6.09	Limitation on Payments and Modifications of Indebtedness; Modifications of Certificate of Incorporation, By-Laws and Certain Other Agreements; etc.	148
Section 6.10	Minimum EBITDAR	151

Section 6.11 Fiscal Year	151
ARTICLE VIA Holding Company Covenants	152
ARTICLE VII Events of Default	152
Section 7.01 Events of Default	152
Section 7.02 Right to Cure	155
Section 7.03 Treatment of Certain Payments	155
ARTICLE VIII The Agents	156
Section 8.01 Appointment	156
Section 8.02 Delegation of Duties	157
Section 8.03 Exculpatory Provisions	157
Section 8.04 Reliance by Agents	158
Section 8.05 Notice of Default	158
Section 8.06 Non-Reliance on Agents and Other Lenders	159
Section 8.07 Indemnification	159
Section 8.08 Agent in Its Individual Capacity	160
Section 8.09 Successor Administrative Agent	160
Section 8.10 Arranger and Syndication Agent	161
Section 8.11 Security Documents and Collateral Agent Under Security Documents and Guarantees	161
Section 8.12 Right to Realize on Collateral and Enforce Guarantees	162
Section 8.13 Secured Hedge Obligations	163
Section 8.14 Withholding Tax	163
Section 8.15 Certain ERISA Matters	164
ARTICLE IX Miscellaneous	166
Section 9.01 Notices; Communications	166
Section 9.02 Survival of Agreement	167
Section 9.03 Binding Effect	167
Section 9.04 Successors and Assigns	167
Section 9.05 Expenses; Indemnity	173
Section 9.06 Right of Set-off	175
Section 9.07 Applicable Law	175
Section 9.08 Waivers; Amendment	176
Section 9.09 Interest Rate Limitation	179
Section 9.10 Entire Agreement	179
Section 9.11 WAIVER OF JURY TRIAL	179
Section 9.12 Severability	179
Section 9.13 Counterparts	180
Section 9.14 Headings	180
Section 9.15 Jurisdiction; Consent to Service of Process	180
Section 9.16 Confidentiality	181
Section 9.17 Platform; Borrower Materials	181
Section 9.18 Release of Liens and Guarantees	182
Section 9.19 Judgment Currency	184
Section 9.20 USA PATRIOT Act Notice	184
Section 9.21 Agency of the Borrower for the Loan Parties	184
Section 9.22 Acknowledgement and Consent to Bail-In of EEA Financial Institutions	184

## Exhibits and Schedules

Exhibit A	Form of Assignment and Acceptance
Exhibit B	Form of Administrative Questionnaire
Exhibit C	Form of Solvency Certificate
Exhibit D-1	Form of Borrowing Request
Exhibit D-2	Form of Swingline Borrowing Request
Exhibit E	Form of Interest Election Request
Exhibit F	[Reserved]
Exhibit G-1	Form of Landlord Agreement
Exhibit G-2	Form of Bailee Agreement
Exhibit H	Form of Borrowing Base Certificate
Exhibit I	[Reserved]
Exhibit J	Form of Non-Bank Tax Certificate
Exhibit K	Certain Subordination Terms
Exhibit L	Form of Borrower Joinder
Exhibit M	Form of Collateral Agreement
Exhibit N	Form of Guarantee Agreement
Exhibit O	Form of Holdings Guarantee and Pledge Agreement

Schedule 1.01(A)	Certain U.S. Subsidiaries
Schedule 1.01(B)	Mortgaged Properties
Schedule 1.01(C)	Immaterial Subsidiaries
Schedule 1.01(D)	Specified Customers
Schedule 1.01(E)	Closing Date Unrestricted Subsidiaries
Schedule 1.01(F)	Acceptable Appraisers
Schedule 1.01(G)	Credit Card Issuers
Schedule 1.01(H)	Credit Card Processors
Schedule 2.01	Commitments
Schedule 3.01	Organization and Good Standing
Schedule 3.04	Governmental Approvals
Schedule 3.05	Financial Statements
Schedule 3.07(b)	Possession under Leases
Schedule 3.08(a)	Subsidiaries
Schedule 3.08(b)	Subscriptions
Schedule 3.09(a)	Litigation
Schedule 3.13	Taxes
Schedule 3.16	Environmental Matters
Schedule 3.21	Insurance
Schedule 3.23	Intellectual Property
Schedule 5.10	Post-Closing Items
Schedule 6.01	Indebtedness
Schedule 6.02(a)	Liens
Schedule 6.04	Investments
Schedule 6.07	Transactions with Affiliates
Schedule 9.01	Notice Information

ASSET-BASED REVOLVING CREDIT AGREEMENT dated as of December 13, 2017 (this "Agreement"), among SCA ACQUISITION, LLC, a Delaware limited liability company ("Holdings"), as of the Closing Date pursuant to a joinder agreement in the form attached hereto as Exhibit L, MN AIRLINES, LLC, a Minnesota limited liability company (d/b/a Sun Country Airlines) (the "Borrower"), the LENDERS party hereto from time to time, and BARCLAYS BANK PLC, as Administrative Agent (in such capacity, the "Administrative Agent") for the Lenders. Capitalized terms used but not defined in this introductory paragraph or the recitals below have the meanings assigned to such terms in Section 1.01.

WHEREAS, Holdings and MINNESOTA AVIATION, LLC, a Minnesota limited liability company (the "Seller"), have entered into that certain Membership Interest Purchase Agreement dated as of December 13, 2017 (as amended or supplemented through the date hereof, the "Purchase Agreement"), pursuant to which Holdings has agreed to acquire from the Seller all of the Equity Interests of the Borrower (the "Acquisition");

WHEREAS, for its general working capital and other limited liability company purposes, Holdings has requested the Lenders to provide the Revolving Facility Commitments (subject to the then applicable Borrowing Base (as hereinafter defined)) in an aggregate principal amount not in excess of \$20,000,000;

NOW, THEREFORE, the Lenders and the Issuing Banks are willing to extend such credit to the Borrower on the terms and subject to the conditions set forth herein. Accordingly, the parties hereto agree as follows:

## ARTICLE I

### *Definitions*

Section 1.01 Defined Terms. As used in this Agreement, the following terms shall have the meanings specified below:

"ABR" shall mean, for any day, a fluctuating rate per annum equal to the greatest of (a) the Prime Rate in effect on such day, (b) the Federal Funds Effective Rate in effect on such day plus 0.50% and (c) the Adjusted LIBOR Rate for an Interest Period of one-month beginning on such day (or if such day is not a Business Day, on the immediately preceding Business Day) (determined as if the relevant ABR Loan were a Eurodollar Loan) plus 1.00%. If the Administrative Agent shall have determined (which determination shall be conclusive absent manifest error) that it is unable to ascertain the Federal Funds Effective Rate or the Adjusted LIBOR Rate for any reason, including the inability or failure of the Administrative Agent to obtain sufficient quotations in accordance with the terms of the definition thereof, the ABR shall be determined without regard to clause (b) or (c) above, as the case may be, of the immediately preceding sentence until the circumstances giving rise to such inability no longer exist. Any change in the ABR due to a change in the Prime Rate, the Federal Funds Effective Rate or the Adjusted LIBOR Rate shall be effective on the effective date of such change in the Prime Rate, the Federal Funds Effective Rate or the Adjusted LIBOR Rate, respectively.

"ABR Borrowing" shall mean a Borrowing comprised of ABR Loans.

“ABR Loan” shall mean any Loan bearing interest at a rate determined by reference to the ABR in accordance with the provisions of Article II.

“Acceptable Appraiser” shall mean (i) Hilco Appraisal Services, LLC or, (ii) another person listed on Schedule 1.01(E) or (iii) any other experienced and reputable appraiser reasonably acceptable to the Borrower and the Administrative Agent, in each case selected and engaged by the Administrative Agent.

“Account” shall mean, with respect to a person, any of such person’s now owned or hereafter acquired or arising Accounts (as defined in the Uniform Commercial Code), including any rights to payment for the sale or lease of goods or rendition of services, whether or not they have been earned by performance.

“Account Control Agreement” shall have the meaning assigned to such term in Section 5.11(a).

“Account Debtor” shall mean, with respect to any Account, each person obligated on such Account.

“Acquisition” shall have the meaning assigned to such term in the first recital hereto.

“Additional Mortgage” shall have the meaning assigned to such term in Section 5.10(c).

“Adjusted LIBOR Rate” shall mean, with respect to any Eurocurrency Borrowing for any Interest Period, an interest rate per annum equal to (a) the LIBOR Rate in effect for such Interest Period divided by (b) one minus the Statutory Reserves applicable to such Eurocurrency Borrowing, if any; provided, that if the Adjusted LIBOR Rate shall be less than zero, such interest rate shall be deemed to be zero.

“Administrative Agent” shall have the meaning assigned to such term in the introductory paragraph of this Agreement, together with its successors and assigns.

“Administrative Agent Fees” shall have the meaning assigned to such term in Section 2.12(c).

“Administrative Questionnaire” shall mean an Administrative Questionnaire in the form of Exhibit B or such other form supplied by the Administrative Agent.

“Affiliate” shall mean, when used with respect to a specified person, another person that directly, or indirectly through one or more intermediaries, Controls or is Controlled by or is under common Control with the person specified.

“Agent Advances” shall mean any Overadvances and Protective Advances.

“Agents” shall mean the Administrative Agent and the Collateral Agent.

“Agreement” shall have the meaning assigned to such term in the introductory paragraph of this Agreement, as amended, restated, supplemented or otherwise modified from time to time.

“Agreement Currency” shall have the meaning assigned to such term in Section 9.19.

“Anti-Corruption Laws” shall have the meaning assigned to such term in Section 3.26.

“Applicable Commitment Fee” shall mean, for any day, 0.50% per annum.

“Applicable Margin” shall mean for any day (i) with respect to any Initial Revolving Facility Loans, 4.00% per annum in the case of any Eurocurrency Loan and 3.00% per annum in the case of any ABR Loan and (ii) with respect to any Extended Revolving Loan, the “Applicable Margin” set forth in the Incremental Assumption Agreement relating thereto.

“Appraisal Triggering Event” shall occur at any time that Availability is less than the greater of (i) 10% of Maximum Availability and (ii) \$5,000,000 for five (5) consecutive Business Days.

“Approved Fund” shall have the meaning assigned to such term in Section 9.04(b)(ii).

“Arranger” shall mean Barclays Bank PLC.

“Asset Sale” shall mean any loss, damage, destruction or condemnation of, or any Disposition (including any sale and leaseback of assets and any mortgage or lease of Real Property) to any person of, any asset or assets of the Borrower or any Subsidiary.

“Assignee” shall have the meaning assigned to such term in Section 9.04(b)(i).

“Assignment and Acceptance” shall mean an assignment and acceptance entered into by a Lender and an Assignee, and accepted by the Administrative Agent and the Borrower (if required by Section 9.04), in the form of Exhibit A or such other form as shall be approved by the Administrative Agent and reasonably satisfactory to the Borrower.

“Availability” shall mean, at any time, an amount equal to the Maximum Availability at such time minus the aggregate Revolving Facility Credit Exposure at such time. If the aggregate Revolving Facility Credit Exposure is equal to or greater than the Revolving Commitments or the Borrowing Base (or the Revolving Commitments have been terminated), Availability is zero.

“Availability Period” shall mean the period from and including the Closing Date to but excluding the earlier of the Maturity Date and the date of termination of the Revolving Commitments.

“Available Unused Commitment” shall mean, as the context may require, (a) with respect to a Lender at any time, an amount equal to the amount by which (i) the Revolving Commitment of such Lender at such time exceeds (ii) the Revolving Facility Credit Exposure of such Lender at such time.

“Bail-In Action” shall mean the exercise of any Write-Down and Conversion Powers by the applicable EEA Resolution Authority in respect of any liability of an EEA Financial Institution.

“Bail-In Legislation” shall mean, with respect to any EEA Member Country implementing Article 55 of Directive 2014/59/EU of the European Parliament and of the Council of the European Union, the implementing law for such EEA Member Country from time to time which is described in the EU Bail-In Legislation Schedule.

“Benefit Plan” shall mean any of (a) an “employee benefit plan” (as defined in ERISA) that is subject to Title I of ERISA, (b) a “plan” as defined in Section 4975 of the Code or (c) any Person whose assets include (for purposes of ERISA Section 3(42) or otherwise for purposes of Title I of ERISA or Section 4975 of the Code) the assets of any such “employee benefit plan” or “plan”.

“Board” shall mean the Board of Governors of the Federal Reserve System of the United States of America.

“Board of Directors” shall mean, as to any person, the board of directors or other governing body of such person, or if such person is not a corporation and is owned or managed by a single entity, the board of directors or other governing body of such entity.

“Bookrunner” shall mean Barclays Bank PLC.

“Borrower” shall have the meaning assigned to such term in the introductory paragraph of this Agreement, together with its successors and assigns.

“Borrower Materials” shall have the meaning assigned to such term in Section 9.17.

“Borrowing” shall mean a group of Loans of a single Type and made on a single date and, in the case of Eurocurrency Loans, as to which a single Interest Period is in effect.

“Borrowing Base” shall mean, at any time, an amount equal to the sum of the following with respect to the Loan Parties, in each case as determined by reference to the most recently delivered Borrowing Base Certificate:

- (a) 90.0% of the Net Amount of Eligible Credit Card Accounts, plus
- (b) 85.0% of the Net Amount of Eligible Accounts, plus
- (c) 75.0% of the Net Book Value of Eligible Inventory, plus

(d) 75.0% of the Net Book Value of Eligible Equipment;

provided that, notwithstanding anything herein to the contrary, the Borrowing Base shall at all times be deemed to be no less than \$5,000,000.

The Borrowing Base shall be reduced by the then amount of all Reserves, without duplication of any items that are otherwise addressed through eligibility criteria, which the Administrative Agent deems necessary in the exercise of its Reasonable Credit Judgment to maintain with respect to the Loan Parties.

The specified percentages set forth in this definition will not be reduced without the consent of the Borrower. Any determination by the Administrative Agent in respect of the Borrowing Base shall be based on the Administrative Agent's Reasonable Credit Judgment. The parties understand that the exclusionary criteria in the definitions of "Eligible Accounts", "Eligible Credit Card Accounts", "Eligible Equipment" and "Eligible Inventory", any Reserves that may be imposed as provided herein, any deductions or other adjustments to determine "book value" and Net Amount of Eligible Accounts and factors considered in the calculation of Net Book Value of Eligible Equipment and Eligible Inventory have the effect of reducing the Borrowing Base, and, accordingly, whether or not any provisions hereof so state, all of the foregoing shall be determined without duplication so as not to result in multiple reductions in the Borrowing Base for the same facts or circumstances.

In connection with the consummation of any acquisition of a business or other assets, the Borrower may submit a calculation of the Borrowing Base on a Pro Forma Basis with adjustments to reflect such acquisition and the inclusion of the Eligible Accounts, Eligible Credit Card Accounts, Eligible Equipment and Eligible Inventory so acquired in the Borrowing Base, and the Borrowing Base and Availability under the Facility shall be increased accordingly; provided, that if such acquisition is a Material Increase Acquisition, the Administrative Agent shall have completed its review of such acquired assets, including receipt of new (or, if agreed to by the Administrative Agent, recently completed) collateral audits, appraisals or updates of appraisals from one or more Acceptable Appraisers as the Administrative Agent shall require in its Reasonable Credit Judgment with respect to any such acquired assets prior to the inclusion of such assets in the Borrowing Base; it being understood that (i) in the case of any Material Increase Acquisition, the Administrative Agent agrees to use its commercially reasonable efforts to complete its review of such acquired assets prior to consummation of such acquisition so long as the Administrative Agent has been given the opportunity for a reasonable period (which shall not be required to be longer than twenty-eight (28) days) to complete such review (and in any event the Administrative Agent agrees to use its commercially reasonable efforts to complete such review as soon as reasonably possible), (ii) the Borrower shall, for the avoidance of doubt, be allowed to utilize any increase in the Borrowing Base resulting from any such adjustment for the purpose of funding the purchase of any such acquired assets, (iii) if such additional assets are of a different type of collateral from the existing assets included in the Borrowing Base, such additional assets may be included in the Borrowing Base as the Administrative Agent shall determine in its Reasonable Credit Judgment and may be subject to different advance rates or eligibility criteria or may require the imposition of additional Reserves with respect thereto as the Administrative Agent shall in its Reasonable Credit Judgment require, and (iv) subject to the provisions of Section 5.10, the Administrative Agent shall have received in form ready for filing



or custody all UCC financing statements or possessory collateral to ensure that, upon such filing, the Collateral Agent will have a perfected security interest in such acquired assets that will meet the requirements therefor set forth in the definition of “Eligible Accounts”, “Eligible Credit Card Accounts”, “Eligible Equipment” and “Eligible Inventory”, as applicable.

Notwithstanding the foregoing, during the period from the Closing Date until the Borrowing Base Effective Date, the Borrowing Base shall be, for all purposes of this Agreement and the other Loan Documents, equal to \$17,500,000. Thereafter, the Borrowing Base shall be \$5,000,000 until the Administrative Agent shall have received, and is reasonably satisfied with, a field examination and appraisal of the assets comprising the Borrowing Base and the initial Borrowing Base Certificate.

“Borrowing Base Certificate” shall mean a certificate by a Responsible Officer of the Borrower, substantially in the form of Exhibit H (or another form reasonably acceptable to the Administrative Agent and the Borrower) setting forth the calculation of the Borrowing Base, including a calculation of each component thereof (including, to the extent the Borrower has received notice of any such Reserve from the Administrative Agent, any of the Reserves included in such calculation), all in such detail as shall be reasonably satisfactory to the Administrative Agent. All calculations of the Borrowing Base in connection with the preparation of any Borrowing Base Certificate shall be made by the Borrower and certified to the Administrative Agent.

“Borrowing Base Effective Date” shall mean the earlier of (a) the Initial Borrowing Base Certificate Date and (b) the Startup Date.

“Borrowing Minimum” shall mean (a) in the case of Eurocurrency Loans, \$200,000, (b) in the case of ABR Loans, \$200,000 and (c) in the case of Swingline Loans, \$200,000.

“Borrowing Multiple” shall mean (a) in the case of Eurocurrency Loans, \$100,000, (b) in the case of ABR Loans, \$100,000 and (c) in the case of Swingline Loans, \$100,000.

“Borrowing Request” shall mean a request by the Borrower in accordance with the terms of Section 2.03 and substantially in the form of Exhibit D-1.

“Budget” shall have the meaning assigned to such term in Section 5.04(e).

“Business Day” shall mean any day that is not a Saturday, Sunday or other day on which commercial banks in New York City are authorized or required by law to remain closed; provided, that when used in connection with a Eurocurrency Loan, the term “Business Day” shall also exclude any day on which banks are not open for dealings in deposits in Dollars in the London interbank market.

“Capital Expenditures” shall mean, for any person in respect of any period, the aggregate of all expenditures incurred by such person during such period that, in accordance with GAAP, are or should be included in “additions to property, plant or equipment” or similar items reflected in the statement of cash flows of such person; provided, however, that Capital Expenditures for the Borrower and the Subsidiaries shall not include:

(a) expenditures to the extent they are made with proceeds of the issuance of Equity Interests (other than Permitted Cure Securities) of, or a cash capital contribution to, the Borrower after the Closing Date,

(b) Capital Expenditures with proceeds of insurance settlements, condemnation awards and other settlements in respect of lost, destroyed, damaged or condemned assets, equipment or other property to the extent such Capital Expenditures are made to replace or repair such lost, destroyed, damaged or condemned assets, equipment or other property or otherwise to acquire, maintain, develop, construct, improve, upgrade or repair assets or properties useful in the business of the Borrower and the Subsidiaries within 15 months of receipt of such proceeds (or, if not made within such period of 15 months, are committed to be made during such period),

(c) interest capitalized during such period,

(d) expenditures that are accounted for as capital expenditures of such person and that actually are paid for by a third party (excluding Holdings, the Borrower or any Subsidiary thereof) and for which neither Holdings, the Borrower nor any Subsidiary has provided or is required to provide or incur, directly or indirectly, any consideration or obligation to such third party or any other person (whether before, during or after such period),

(e) the book value of any asset owned by such person prior to or during such period to the extent that such book value is included as a capital expenditure during such period as a result of such person reusing or beginning to reuse such asset during such period without a corresponding expenditure actually having been made in such period; provided, that (i) any expenditure necessary in order to permit such asset to be reused shall be included as a Capital Expenditure during the period that such expenditure actually is made and (ii) such book value shall have been included in Capital Expenditures when such asset was originally acquired,

(f) the purchase price of equipment purchased during such period to the extent the consideration therefor consists of any combination of (i) used or surplus equipment traded in at the time of such purchase and (ii) the proceeds of a concurrent sale of used or surplus equipment, in each case, in the ordinary course of business,

(g) Investments in respect of a Permitted Business Acquisition, or

(h) the purchase of property, plant or equipment made within 15 months of the sale of any asset to the extent purchased with the proceeds of such sale (or, if not made within such period of 15 months, to the extent committed to be made during such period).

“Capital Lease” shall mean, as applied to any person, any lease of any property (whether real, personal or mixed) by that person as lessee that, in conformity with GAAP, is, or is required to be, accounted for as a capital lease on the balance sheet of that person.

“Capitalized Lease Obligations” shall mean, as applied to any person, all obligations under Capital Leases of such person or any of its subsidiaries, in each case taken at the amount thereof accounted for as liabilities in accordance with GAAP.

“Capitalized Software Expenditures” shall mean, for any period, the aggregate of all expenditures (whether paid in cash or accrued as liabilities) by a person during such period in respect of licensed or purchased software or internally-developed software and software enhancements that, in accordance with GAAP, are or are required to be reflected as capitalized costs on the consolidated balance sheet of such person and its subsidiaries.

“Cash Collateralize” shall mean to pledge and deposit with or deliver to the Collateral Agent, for the benefit of one or more of the Issuing Banks or Lenders, as collateral for Revolving L/C Exposure or obligations of the Lenders to fund participations in respect of Revolving L/C Exposure, cash or deposit account balances or, if the Collateral Agent and each Issuing Bank shall agree in their sole discretion, other credit support, in each case pursuant to documentation in form and substance reasonably satisfactory to the Collateral Agent and each applicable Issuing Bank. “Cash Collateral” and “Cash Collateralization” shall have a meaning correlative to the foregoing and shall include the proceeds of such cash collateral and other credit support.

“Cash Dominion Triggering Event” shall occur at any time that (a) Availability is less than \$3,000,000 for five (5) consecutive Business Days or (b) an Event of Default shall have occurred and be continuing. Once occurred, a Cash Dominion Triggering Event described in clause (a) shall be deemed to be continuing until such time as the Availability is at least equal to \$3,000,000 for fifteen (15) consecutive Business Days, and a Cash Dominion Triggering Event described in clause (b) shall be deemed to be continuing until no Event of Default shall be continuing.

“Cash Interest Expense” shall mean, with respect to the Borrower and the Subsidiaries on a consolidated basis for any period, Interest Expense for such period, less the sum of, without duplication, (a) pay-in-kind Interest Expense or other non-cash Interest Expense (including as a result of the effects of purchase accounting), (b) to the extent included in Interest Expense, the amortization of any financing fees paid by, or on behalf of, the Borrower or any Subsidiary, including such fees paid in connection with the Transactions, and (c) the amortization of debt discounts, if any, or fees in respect of Hedging Agreements; provided, that Cash Interest Expense shall exclude any one time financing fees, including those paid in connection with the Transactions or any amendment of this Agreement.

“Cash Management Agreement” shall mean any agreement to provide to Holdings, the Borrower or any Subsidiary cash management services for collections, treasury management services (including controlled disbursement, overdraft, automated clearing house fund transfer services, return items and interstate depository network services), any demand deposit, payroll, trust or operating account relationships, commercial credit cards, merchant card, purchase or debit cards, non-card e-payables services, and other cash management services, including electronic funds transfer services, lockbox services, stop payment services and wire transfer services.

“Cash Management Bank” shall mean any person that, at the time it enters into a Cash Management Agreement (or on the Closing Date), is an Agent, an Arranger, a Lender or an Affiliate of any such person, in each case, in its capacity as a party to such Cash Management Agreement.

“CFC” shall mean a “controlled foreign corporation” within the meaning of section 957(a) of the Code.

A “Change in Control” shall be deemed to occur if:

(a) (i) at any time prior to a Qualified IPO, (x) the Permitted Holders shall at any time cease to have, directly or indirectly, the power to vote or direct the voting of at least 35% of the Voting Stock of the Borrower or (y) any person, entity or “group” (within the meaning of Section 13(d) or 14(d) of the Exchange Act, but excluding any employee benefit plan of such person, entity or “group” and its subsidiaries and any person or entity acting in its capacity as trustee, agent or other fiduciary or administrator of any such plan), other than the Permitted Holders, shall at any time have acquired direct or indirect beneficial ownership (as defined in Rules 13(d)-3 and 13(d)-5 under the Exchange Act) of a percentage of the voting power of the outstanding Voting Stock of the Borrower that is greater than the percentage of such voting power of such Voting Stock in the aggregate, directly or indirectly, beneficially owned by the Permitted Holders or (ii) at any time on and after a Qualified IPO, any person, entity or “group” (within the meaning of Section 13(d) or 14(d) of the Exchange Act, but excluding any employee benefit plan of such person, entity or “group” and its subsidiaries and any person or entity acting in its capacity as trustee, agent or other fiduciary or administrator of any such plan), other than the Permitted Holders (or any holding company parent of the Borrower owned directly or indirectly by the Permitted Holders), shall at any time have acquired direct or indirect beneficial ownership (as defined in Rules 13(d)-3 and 13(d)-5 under the Exchange Act) of voting power of the outstanding Voting Stock of the Borrower having more than the greater of (A) 35% of the ordinary voting power for the election of directors of the Borrower and (B) the percentage of the ordinary voting power for the election of directors of the Borrower owned in the aggregate, directly or indirectly, beneficially, by the Permitted Holders, unless in the case of either clause (i) or (ii) of this clause (a), the Permitted Holders have, at such time, the right or the ability by voting power, contract or otherwise to elect or designate for election at least a majority of the members of the Board of Directors of the Borrower; or

(b) at any time on or after a Qualified IPO, during any period of twelve (12) consecutive months, a majority of the seats (other than vacant seats) on the Board of Directors of the Borrower shall be occupied by individuals who were neither (1) nominated by the Board of Directors of the Borrower or a Permitted Holder, (2) appointed by directors so nominated nor (3) appointed by a Permitted Holder; or

(c) a “Change of Control” or similar term (as defined in any Junior or Specified Financing constituting Material Indebtedness) shall have occurred; or

(d) Holdings shall fail to own directly, beneficially and of record, 100% of the issued and outstanding Equity Interests of the Borrower (other than after a Qualified IPO).

“Change in Law” shall mean (a) the adoption of any law, rule or regulation after the Closing Date, (b) any change in law, rule or regulation or in the interpretation or application thereof by any Governmental Authority after the Closing Date or (c) compliance by any Lender (or, for purposes of Section 2.15(b), by any Lending Office of such Lender or by such Lender’s holding company, if any) with any written request, guideline or directive (whether or not having the force of law) of any Governmental Authority made or issued after the Closing Date; provided, however, that notwithstanding anything herein to the contrary, (x) all requests, rules, guidelines or directives under or issued in connection with the Dodd-Frank Wall Street Reform and Consumer Protection Act, all interpretations and applications thereof and any compliance by a Lender with any request or directive relating thereto and (y) all requests, rules, guidelines or directives promulgated under or in connection with, all interpretations and applications of, or any compliance by a Lender with any request or directive relating to International Settlements, the Basel Committee on Banking Supervision (or any successor or similar authority) or the U.S. or foreign regulatory authorities, in each case pursuant to Basel III, shall in each case under this clauses (x) and (y) be deemed to be a “Change in Law” but only to the extent a Lender is imposing applicable increased costs or costs in connection with capital adequacy requirements similar to those described in clauses (a) and (b) of Section 2.15 generally on other borrowers of loans under comparable U.S. credit facilities.

“Charges” shall have the meaning assigned to such term in Section 9.09.

“Class” shall mean, (a) when used in respect of any Loan or Borrowing, whether such Loan or the Loans comprising such Borrowing are Revolving Facility Loans or Extended Revolving Loans; and (b) when used in respect of any Commitment, whether such Commitment is in respect of a Revolving Facility Commitment or an Extended Revolving Commitment. Extended Revolving Loans that have different terms and conditions (together with the Commitments in respect thereof) shall be construed to be in different Classes.

“Closing Date” shall mean the date on which the conditions set forth in Section 4.03 are satisfied (or waived in accordance with the terms hereof).

“Code” shall mean the Internal Revenue Code of 1986, as amended.

“Co-Investors” shall mean (a) the Fund and Fund Affiliates (excluding any of their portfolio companies) and (b) the Management Group.

“Collateral” shall mean all the “Collateral” as defined in any Security Document and shall also include the Mortgaged Properties and all other property that is subject to any Lien in favor of the Administrative Agent, the Collateral Agent or any Subagent for the benefit of the Secured Parties pursuant to any Security Document.

“Collateral Access Agreement” shall mean any landlord waivers, mortgagee waivers, bailee letters or any similar acknowledgment agreements of any landlord, lessor, warehouseman or processor (other than a Loan Party) in possession of Inventory or Equipment, substantially in the form of Exhibit G-1 or Exhibit G-2, as applicable or another form reasonably acceptable to the Administrative Agent.

“Collateral Agent” shall mean the Administrative Agent acting as collateral agent for the Secured Parties.

“Collateral Agent Account” shall have the meaning assigned to such term in Section 5.11(b).

“Collateral Agreement” shall mean the Collateral Agreement (ABL Facility), substantially in the form of Exhibit M, among the Borrower, each Subsidiary Loan Party (if any) and the Collateral Agent, as amended, restated, supplemented or otherwise modified from time to time.

“Collateral and Guarantee Requirement” shall mean the requirement that (in each case subject to Sections 5.10 (d), (e) and (g), Schedule 5.10, and any Permitted Intercreditor Agreement):

- (a) on the Closing Date, the Collateral Agent shall have received (i) from the Borrower and each Subsidiary Loan Party (if any), a counterpart of the Collateral Agreement, (ii) from each Subsidiary Loan Party (if any), a counterpart of the Guarantee Agreement and (iii) from Holdings, a counterpart of the Holdings Guarantee and Pledge Agreement, in each case, duly executed and delivered on behalf of such person;
- (b) on the Closing Date, (i)(x) all outstanding Equity Interests of the Borrower and all other outstanding Equity Interests, in each case, directly owned by the Loan Parties, other than Excluded Securities, and (y) all Indebtedness owing to any Loan Party, other than Excluded Securities, shall have been pledged pursuant to the Collateral Agreement or the Holdings Guarantee and Pledge Agreement, and (ii) the Collateral Agent shall have received certificates or other instruments (if any) representing such Equity Interests and any notes or other instruments required to be delivered pursuant to the applicable Security Documents, together with stock powers, note powers or other instruments of transfer with respect thereto endorsed in blank;
- (c) in the case of any person that becomes a Subsidiary Loan Party after the Closing Date, the Collateral Agent shall have received (i) a supplement to the Collateral Agreement, (ii) a supplement to the Guarantee Agreement and (iii) supplements to the other Security Documents, if applicable, in the form specified therefor or otherwise reasonably acceptable to the Administrative Agent, in each case, duly executed and delivered on behalf of such Subsidiary Loan Party;
- (d) after the Closing Date, (x) all outstanding Equity Interests of any person that becomes a Subsidiary Loan Party after the Closing Date and (y) subject to Section 5.10(g), all Equity Interests directly acquired by a Loan Party after the Closing Date, other than Excluded Securities, shall have been pledged pursuant to the Collateral Agreement, together with stock powers or other instruments of transfer with respect thereto endorsed in blank;

- (e) except as otherwise contemplated by this Agreement or any Security Document, all documents and instruments, including Uniform Commercial Code financing statements, and filings with the United States Copyright Office and the United States Patent and Trademark Office, and all other actions required by the applicable Requirement of Law or reasonably requested by the Collateral Agent to be delivered, filed, registered or recorded to create the Liens intended to be created by the Security Documents (in each case, including any supplements thereto) and perfect such Liens to the extent required by, and with the priority required by, the Security Documents, shall have been delivered, filed, registered or recorded or delivered to the Collateral Agent for filing, registration or the recording concurrently with, or promptly following, the execution and delivery of each such Security Document or supplement thereto;
- (f) within (x) 90 days after the Closing Date with respect to the Mortgaged Property set forth on Schedule 1.01(B), if any, (or on such later date as the Collateral Agent may agree in its reasonable discretion) and (y) within the time periods set forth in Section 5.10 with respect to Mortgaged Properties required to be encumbered pursuant to said Section 5.10, the Collateral Agent shall have received (i) counterparts of each Mortgage to be entered into with respect to each such Mortgaged Property duly executed and delivered by the record owner of such Mortgaged Property and suitable for recording or filing in all filing or recording offices that the Collateral Agent may reasonably deem necessary or desirable in order to create a valid and enforceable Lien subject to no other Liens except Permitted Liens, at the time of recordation thereof, (ii) with respect to the Mortgage encumbering each such Mortgaged Property, opinions of counsel regarding the enforceability, due authorization, execution and delivery of the Mortgages and such other matters customarily covered in real estate counsel opinions as the Collateral Agent may reasonably request, in form and substance reasonably acceptable to the Collateral Agent, (iii) with respect to each such Mortgaged Property, the Flood Documentation and (iv) such other documents as the Collateral Agent may reasonably request with respect to any such Mortgage or Mortgaged Property;
- (g) within (x) 90 days after the Closing Date with respect to the Mortgaged Property set forth on Schedule 1.01(B), if any, (or on such later date as the Collateral Agent may agree in its reasonable discretion) and (y) within the time periods set forth in Section 5.10 with respect to Mortgaged Properties required to be encumbered pursuant to Section 5.10, the Collateral Agent shall have received (i) a policy or policies or marked up unconditional binder of title insurance with respect to properties located in the United States of America, paid for by the Borrower, issued by a nationally recognized title insurance company insuring the Lien of each Mortgage as a valid Lien on the Mortgaged Property described therein, free of any other Liens except Permitted Liens, in an amount reasonably acceptable to the Collateral Agent with respect to such Mortgaged Property (not to exceed the fair market value of the applicable Mortgaged Property, as determined in good faith by the

Borrower) together with such customary endorsements, coinsurance and reinsurance as the Collateral Agent may reasonably request and which are available at commercially reasonable rates in the jurisdiction where the applicable Mortgaged Property is located and (ii) a survey or survey alternative (such as an express or aerial map) of each Mortgaged Property (including all improvements, easements and other customary matters thereon reasonably required by the Collateral Agent), as applicable, for which all necessary fees (where applicable) have been paid with respect to properties located in the United States of America, which is sufficient for such title insurance company to remove all standard survey exceptions from the title insurance policy relating to such Mortgaged Property or otherwise reasonably acceptable to the Collateral Agent;

- (h) on the Closing Date, the Collateral Agent shall have received evidence of the insurance required by the terms of Section 5.02 hereof; and
- (i) after the Closing Date, the Collateral Agent shall have received (i) such other Security Documents as may be required to be delivered pursuant to Section 5.10 or the Collateral Agreement, and (ii) upon reasonable request by the Collateral Agent, evidence of compliance with any other requirements of Section 5.10.

“Collateral Audit” shall mean a collateral examination of the inventory, equipment, accounts receivable (including credit card accounts receivable), accounts payable, books and records and the accounting systems, policies and procedures of the Borrower and its Subsidiaries by the Administrative Agent or by a third-party consultant reasonably satisfactory to the Administrative Agent and the Borrower, the results of which audit, if conducted by such consultant, shall be in a form and prepared on a basis reasonably satisfactory to the Administrative Agent.

“Commitment Fee” shall have the meaning assigned to such term in Section 2.12(a).

“Commitments” shall mean (a) with respect to any Lender, such Lender’s Revolving Commitment (which may include any commitment in respect of Revolving Facility Loans or Extended Revolving Loans) and (b) with respect to any Swingline Lender, its Swingline Commitment (it being understood that the Swingline Commitment does not increase the Swingline Lender’s Revolving Commitment).

“Commodity Exchange Act” means the Commodity Exchange Act (7 U.S.C. § 1 et seq.), as amended from time to time, and any successor statute.

“Conduit Lender” shall mean any special purpose corporation organized and administered by any Lender for the purpose of making Loans otherwise required to be made by such Lender and designated by such Lender in a written instrument; provided, that the designation by any Lender of a Conduit Lender shall not relieve the designating Lender of any of its obligations to fund a Loan under this Agreement if, for any reason, its Conduit Lender fails to



fund any such Loan, and the designating Lender (and not the Conduit Lender) shall have the sole right and responsibility to deliver all consents and waivers required or requested under this Agreement with respect to its Conduit Lender; provided, further, that no Conduit Lender shall (a) be entitled to receive any greater amount pursuant to Section 2.15, 2.16, 2.17 or 9.05 than the designating Lender would have been entitled to receive in respect of the extensions of credit made by such Conduit Lender or (b) be deemed to have any Commitment.

“Consolidated Debt” at any date shall mean the sum of (without duplication) all Indebtedness (other than letters of credit or bank guarantees, to the extent undrawn) consisting of Capitalized Lease Obligations, Indebtedness for borrowed money and Disqualified Stock of the Borrower and the Subsidiaries determined on a consolidated basis on such date in accordance with GAAP.

“Consolidated Net Income” shall mean, with respect to any person for any period, the aggregate of the Net Income of such person and its subsidiaries for such period, on a consolidated basis; provided, however, that, without duplication,

(i) any net after-tax extraordinary, nonrecurring or unusual gains or losses or income or expense or charge (less all fees and expenses relating thereto), any severance, relocation or other restructuring expenses, any expenses related to any New Project or any reconstruction, decommissioning, recommissioning or reconfiguration of fixed assets for alternative uses, fees, expenses or charges relating to facilities closing costs, curtailments or modifications to pension and post-retirement employee benefit plans, excess pension charges, acquisition integration costs, facilities opening and integration costs, signing, retention or completion bonuses, and expenses or charges related to any offering of Equity Interests or debt securities of the Borrower, Holdings or any Parent Entity, any Investment, acquisition, Disposition, recapitalization or issuance, repayment, refinancing, amendment or modification of Indebtedness (in each case, whether or not successful), and any fees, expenses, charges or change in control payments related to the Transactions (including any costs relating to auditing prior periods, any transition or startup-related expenses, and Transaction Expenses incurred before, on or after the Closing Date), in each case, shall be excluded,

(ii) any net after-tax income or loss from Disposed of, abandoned, closed or discontinued operations or fixed assets and any net after-tax gain or loss on the Dispositions of Disposed of, abandoned, closed or discontinued operations or fixed assets shall be excluded,

(iii) any net after-tax gain or loss (less all fees and expenses or charges relating thereto) attributable to business Dispositions or asset Dispositions other than in the ordinary course of business (as determined in good faith by the management of the Borrower) shall be excluded,

(iv) any net after-tax income or loss (less all fees and expenses or charges relating thereto) attributable to the early extinguishment of indebtedness, Hedging Agreements or other derivative instruments shall be excluded,

(v) (A) the Net Income for such period of any person that is not a subsidiary of such person, or is an Unrestricted Subsidiary, or that is accounted for by the equity method of accounting, shall be included only to the extent of the amount of dividends or distributions or other payments paid in cash (or to the extent converted into cash) to the referent person or a subsidiary thereof (other than an Unrestricted Subsidiary of such referent person) in respect of such period and (B) the Net Income for such period shall include any dividend, distribution or other payment in cash (or to the extent converted into cash) received by the referent person or a subsidiary thereof (other than an Unrestricted Subsidiary of such referent person) from any person in excess of, but without duplication of, the amounts included in subclause (A),

(vi) the cumulative effect of a change in accounting principles during such period shall be excluded,

(vii) effects of purchase accounting adjustments (including the effects of such adjustments pushed down to such person and its subsidiaries) in component amounts required or permitted by GAAP, resulting from the application of purchase accounting or the amortization or write-off of any amounts thereof, net of taxes, shall be excluded,

(viii) any impairment charges or asset write-offs, in each case pursuant to GAAP, and the amortization of intangibles and other fair value adjustments arising pursuant to GAAP, shall be excluded,

(ix) any non-cash compensation charge or expenses realized or resulting from stock option plans, employee benefit plans or post-employment benefit plans, or grants or sales of stock, stock appreciation or similar rights, stock options, restricted stock, preferred stock or other rights shall be excluded,

(x) accruals and reserves that are established or adjusted within twelve months after the Closing Date and that are so required to be established or adjusted in accordance with GAAP or as a result of adoption or modification of accounting policies shall be excluded,

(xi) non-cash gains, losses, income and expenses resulting from fair value accounting required by the applicable standard under GAAP and related interpretation shall be excluded,

(xii) any gain, loss, income, expense or charge resulting from the application of any LIFO shall be excluded,

(xiii) any non-cash charges for deferred tax asset valuation allowances and deferred tax liabilities shall be excluded,

(xiv) any currency translation gains and losses related to currency remeasurements of Indebtedness, and any net loss or gain resulting from Hedging Agreements for currency exchange risk, shall be excluded,

(xv) any deductions attributable to minority interests shall be excluded,

(xvi) (A) the non-cash portion of “straight-line” rent expense shall be excluded and (B) the cash portion of “straight-line” rent expense which exceeds the amount expensed in respect of such rent expense shall be included,

(xvii) (A) to the extent covered by insurance and actually reimbursed, or, so long as such person has made a determination that there exists reasonable evidence that such amount will in fact be reimbursed by the insurer and only to the extent that such amount is (x) not denied by the applicable carrier in writing within 180 days and (y) in fact reimbursed within 365 days following the date of such evidence (with a deduction for any amount so added back to the extent not so reimbursed within such 365 days), expenses with respect to liability or casualty events or business interruption shall be excluded; and (B) amounts estimated in good faith to be received from insurance in respect of lost revenues or earnings in respect of liability or casualty events or business interruption shall be included (with a deduction for amounts actually received up to such estimated amount to the extent included in Net Income in a future period), and

(xviii) without duplication, an amount equal to the amount of distributions actually made to any parent or equity holder of such person in respect of such period in accordance with Section 6.06(b)(v) shall be included as though such amounts had been paid as income taxes directly by such person for such period.

“Consolidated Total Assets” shall mean, as of any date of determination, the total assets of the Borrower and the consolidated Subsidiaries without giving effect to any amortization of the amount of intangible assets since the Closing Date, determined on a consolidated basis in accordance with GAAP, as set forth on the consolidated balance sheet of the Borrower and the Subsidiaries as of the last day of the fiscal quarter most recently ended for which financial statements have been (or were required to be) delivered pursuant to Section 5.04(a) or Section 5.04(b), as applicable, calculated on a Pro Forma Basis after giving effect to any acquisition or Disposition of a person or assets that may have occurred on or after the last day of such fiscal quarter.

“Control” shall mean the possession, directly or indirectly, of the power to direct or cause the direction of the management or policies of a person, whether through the ownership of voting securities, by contract or otherwise, and “Controlling” and “Controlled” shall have meanings correlative thereto.

“Controlled Account” shall mean any account of any Loan Party that is subject to an Account Control Agreement.

“Credit Card Agreements” means all agreements now or hereafter entered into with any Credit Card Issuer or any Credit Card Processor, as the same now exist or may hereafter be amended, modified, supplemented, extended, renewed, restated or replaced.

“Credit Card Issuer” means any of the credit card issuers listed on Schedule 1.01(G) (as attached hereto by the Borrower as of the Closing Date) and any other credit card issuer identified by the Borrower to the Administrative Agent from time to time.

“Credit Card Processor” means any of the credit card processors or clearinghouses listed on Schedule 1.01(H) (as attached hereto by the Borrower as of the Closing Date) and any other credit card processor or clearinghouse identified by the Borrower to the Administrative Agent from time to time.

“Credit Card Receivables” means, collectively, all present and future rights of any Loan Party to payment from any Credit Card Issuer, Credit Card Processor or other third party arising from customers who have made purchases using a credit or debit card.

“Credit Event” shall have the meaning assigned to such term in Article IV.

“Cure Amount” shall have the meaning assigned to such term in Section 7.02.

“Cure Right” shall have the meaning assigned to such term in Section 7.02.

“Debtor Relief Laws” shall mean the U.S. Bankruptcy Code, and all other liquidation, conservatorship, bankruptcy, assignment for the benefit of creditors, moratorium, rearrangement, receivership, insolvency, reorganization, or similar debtor relief laws of the United States of America or other applicable jurisdictions from time to time in effect.

“Default” shall mean any event or condition that upon notice, lapse of time or both would constitute an Event of Default.

“Defaulting Lender” shall mean, subject to Section 2.22, any Lender that (a) has failed to (i) fund all or any portion of its Loans within two Business Days of the date such Loans were required to be funded hereunder unless such Lender notifies the Administrative Agent and the Borrower in writing that such failure is the result of such Lender’s determination that one or more conditions precedent to funding (each of which conditions precedent, together with any applicable default, shall be specifically identified in such writing) has not been satisfied, or (ii) pay to the Administrative Agent, any Issuing Bank, the Swingline Lender or any other Lender any other amount required to be paid by it hereunder (including in respect of its participation in Letters of Credit or Swingline Loans) within two Business Days of the date when due, (b) has notified the Borrower, the Administrative Agent, the Swingline Lender or any Issuing Bank in writing that it does not intend to comply with its funding obligations hereunder, or has made a public statement to that effect (unless such writing or public statement relates to such Lender’s obligation to fund a Loan hereunder and states that such position is based on such Lender’s determination that a condition precedent to funding (which condition precedent, together with any applicable default, shall be specifically identified in such writing or public statement) cannot be satisfied), (c) has failed, within three Business Days after written request by the Administrative Agent or the Borrower, to confirm in writing to the Administrative Agent and the Borrower that it will comply with its prospective funding obligations hereunder (provided, that such Lender shall cease to be a Defaulting Lender pursuant to this clause (c) upon receipt of such written confirmation by the Administrative Agent and the Borrower) or (d) has, or has a direct or indirect parent company that has, (i) become the subject of a proceeding under any Debtor Relief Law, (ii) had appointed for it a receiver, custodian, conservator, trustee, administrator, assignee for the benefit of creditors or similar person charged with reorganization or liquidation of its business or assets, including the Federal Deposit Insurance Corporation or

any other state or federal regulatory authority acting in such a capacity, or (iii) become the subject of a Bail-In Action; provided, that a Lender shall not be a Defaulting Lender solely by virtue of the ownership or acquisition of any equity interest in that Lender or any direct or indirect parent company thereof by a Governmental Authority so long as such ownership interest does not result in or provide such Lender with immunity from the jurisdiction of courts within the United States of America or from the enforcement of judgments or writs of attachment on its assets or permit such Lender (or such Governmental Authority) to reject, repudiate, disavow or disaffirm any contracts or agreements made with such Lender. Any determination by the Administrative Agent that a Lender is a Defaulting Lender under any one or more of clauses (a) through (d) above shall be conclusive and binding absent manifest error, and such Lender shall be deemed to be a Defaulting Lender (subject to Section 2.22) upon delivery of written notice of such determination to the Borrower, each Issuing Bank, the Swingline Lender and each Lender.

“Designated Disbursement Account” shall have the meaning assigned to such term in Section 5.11(f).

“Designated Non-Cash Consideration” shall mean the fair market value (as determined in good faith by the Borrower) of non-cash consideration received by the Borrower or one of the Subsidiaries in connection with an Asset Sale that is so designated as Designated Non-Cash Consideration pursuant to a certificate of a Responsible Officer of the Borrower, setting forth the basis of such valuation, less the amount of cash or cash equivalents received in connection with a subsequent Disposition of such Designated Non-Cash Consideration.

“Designated Pari Passu Amount” shall have the meaning assigned to such term in Section 8.13.

“Designation Notice” shall have the meaning assigned to such term in Section 8.13.

“Disinterested Director” shall mean, with respect to any person and transaction, a member of the Board of Directors of such person who does not have any material direct or indirect financial interest in or with respect to such transaction.

“Dispose” or “Disposed of” shall mean to convey, sell, lease, sell and leaseback, assign, farm-out, transfer or otherwise dispose of any property, business or asset. The term “Disposition” shall have a correlative meaning to the foregoing.

“Disqualified Stock” shall mean, with respect to any person, any Equity Interests of such person that, by its terms (or by the terms of any security or other Equity Interests into which it is convertible or for which it is exchangeable), or upon the happening of any event or condition (a) matures or is mandatorily redeemable (other than solely for Qualified Equity Interests), pursuant to a sinking fund obligation or otherwise (except as a result of a change of control or asset sale so long as any rights of the holders thereof upon the occurrence of a change of control or asset sale event shall be subject to the prior repayment in full of the Loans and all other Loan Obligations that are accrued and payable and the termination of the Commitments), (b) is redeemable at the option of the holder thereof (other than solely for Qualified Equity Interests), in whole or in part, (c) provides for the scheduled payments of dividends in cash, or

(d) is or becomes convertible into or exchangeable for Indebtedness or any other Equity Interests that would constitute Disqualified Stock, in each case, prior to the date that is ninety-one (91) days after the Latest Maturity Date in effect at the time of the issuance thereof (provided, that only the portion of the Equity Interests that so mature or are mandatorily redeemable, are so convertible or exchangeable or are so redeemable at the option of the holder thereof prior to such date shall be deemed to be Disqualified Stock). Notwithstanding the foregoing: (i) any Equity Interests issued to any employee or to any plan for the benefit of employees of the Borrower or the Subsidiaries or by any such plan to such employees shall not constitute Disqualified Stock solely because they may be required to be repurchased by the Borrower in order to satisfy applicable statutory or regulatory obligations or as a result of such employee's termination, death or disability and (ii) any class of Equity Interests of such person that by its terms authorizes such person to satisfy its obligations thereunder by delivery of Equity Interests that are not Disqualified Stock shall not be deemed to be Disqualified Stock.

"Dollar Equivalent" shall mean, at any time, (a) with respect to any amount denominated in Dollars, such amount, and (b) with respect to any amount denominated in any currency other than Dollars, the equivalent amount thereof in Dollars as determined by the Administrative Agent at such time on the basis of the Spot Rate (determined in respect of the applicable date of determination) for the purchase of Dollars with such currency.

"Dollars" or "\$" shall mean lawful money of the United States of America.

"Domestic Subsidiary" shall mean any Subsidiary that is not a Foreign Subsidiary.

"DOT" shall mean the United States Department of Transportation and any successor thereto.

"EBITDAR" shall mean, with respect to the Borrower and the Subsidiaries on a consolidated basis for any period, the Consolidated Net Income of the Borrower and the Subsidiaries for such period plus (a) the sum of (in each case without duplication and to the extent the respective amounts described in subclauses (i) through (xiii) of this clause (a) reduced such Consolidated Net Income (and were not excluded therefrom) for the respective period for which EBITDAR is being determined):

(i) provision for Taxes based on income, profits or capital of the Borrower and the Subsidiaries for such period, including state, franchise and similar taxes and foreign withholding taxes (including penalties and interest related to taxes or arising from tax examinations) and the amount of distributions pursuant to Section 6.06(b)(iii) and Section 6.06(b)(v) in respect of such period,

(ii) Interest Expense (and to the extent not included in Interest Expense, (x) all cash dividend payments (excluding items eliminated in consolidation) on any series of preferred stock or Disqualified Stock and (y) costs of surety bonds in connection with financing activities) of the Borrower and the Subsidiaries for such period (net of interest income of the Borrower and the Subsidiaries for such period),

(iii) depreciation and amortization expenses of the Borrower and the Subsidiaries for such period including the amortization of intangible assets, deferred financing fees and Capitalized Software Expenditures and amortization of unrecognized prior service costs and actuarial gains and losses related to pensions and other post-employment benefits,

(iv) business optimization expenses and other restructuring charges or reserves (which, for the avoidance of doubt, shall include the effect of inventory, marketing or sales optimization programs, facility closure, facility consolidations, retention, severance, systems establishment costs, contract termination costs, future lease commitments and excess pension charges),

(v) any other non-cash charges; provided, that for purposes of this subclause (v) of this clause (a), any non-cash charges or losses shall be treated as cash charges or losses in any subsequent period during which cash disbursements attributable thereto are made (but excluding, for the avoidance of doubt, amortization of a prepaid cash item that was paid in a prior period),

(vi) the amount of management, consulting, monitoring, transaction and advisory fees and related expenses paid to the Fund or any Fund Affiliate (or any accruals related to such fees and related expenses) during such period not in contravention of this Agreement,

(vii) any expenses or charges (other than depreciation or amortization expense as described in the preceding clause (iii)) related to any issuance of Equity Interests, Investment, acquisition, New Project, Disposition, recapitalization or the incurrence, modification or repayment of Indebtedness permitted to be incurred by this Agreement (including a refinancing thereof) (whether or not successful), including (x) such fees, expenses or charges related to this Agreement and (y) any amendment or other modification of the Obligations or other Indebtedness,

(viii) any costs or expense incurred pursuant to any management equity plan or stock option plan or any other management or employee benefit plan or agreement or any stock subscription or shareholder agreement, to the extent that such costs or expenses are funded with cash proceeds contributed to the capital of the Borrower or a Subsidiary Loan Party (other than contributions received from the Borrower or another Subsidiary Loan Party) or net cash proceeds of an issuance of Equity Interests of the Borrower (other than Disqualified Stock),

(ix) non-operating expenses,

(x) the amount of any loss attributable to a New Project, until the date that is 12 months after the date of completing the undertaking, construction, acquisition, assembling or creation of such New Project, as the case may be; provided, that (A) such losses are reasonably identifiable and factually supportable and certified by a Responsible Officer of the Borrower and (B) losses attributable to such New Project after 12 months from the date of completing such undertaking, construction, acquisition, assembling or creation, as the case may be, shall not be included in this clause (x),

(xi) with respect to any joint venture that is not a Subsidiary and solely to the extent relating to any net income referred to in clause (v) of the definition of “Consolidated Net Income”, an amount equal to the proportion of those items described in clauses (i) and (ii) above relating to such joint venture corresponding to the Borrower’s and the Subsidiaries’ proportionate share of such joint venture’s Consolidated Net Income (determined as if such joint venture were a Subsidiary),

(xii) one-time costs associated with commencing Public Company Compliance and

(xiii) all rent expense, which for the avoidance of doubt shall include engine rent expense otherwise reported as a component of maintenance expense;

minus (b) the sum of (without duplication and to the extent the amounts described in this clause (b) increased such Consolidated Net Income for the respective period for which EBITDAR is being determined) non-cash items increasing Consolidated Net Income of the Borrower and the Subsidiaries for such period (but excluding any such items (A) in respect of which cash was received in a prior period or will be received in a future period or (B) which represent the reversal of any accrual of, or cash reserve for, anticipated cash charges that reduced EBITDAR in any prior period).

“EEA Financial Institution” means (a) any credit institution or investment firm established in any EEA Member Country which is subject to the supervision of an EEA Resolution Authority, (b) any entity established in an EEA Member Country which is a parent of an institution described in clause (a) of this definition, or (c) any financial institution established in an EEA Member Country which is a subsidiary of an institution described in clauses (a) or (b) of this definition and is subject to consolidated supervision with its parent.

“EEA Member Country” means any of the member states of the European Union, Iceland, Liechtenstein, and Norway.

“EEA Resolution Authority” means any public administrative authority or any person entrusted with public administrative authority of any EEA Member Country (including any delegee) having responsibility for the resolution of any EEA Financial Institution.

“Effective Date” shall mean the date on which the conditions set forth in Section 4.02 are satisfied (or waived in accordance with the terms hereof).

“Eligible Accounts” shall mean all Accounts of the Loan Parties reflected in the most recent Borrowing Base Certificate, except any Account with respect to which any of the exclusionary criteria set forth below applies (unless the Administrative Agent in its sole discretion elects to include such Account) and excluding, for the avoidance of doubt, any Eligible Credit Card Accounts. No Account shall be an Eligible Account if:

(i) it arises out of a sale made or services rendered by the applicable Loan Party to a direct or indirect parent or Subsidiary of such Loan Party, or if not on arm’s length terms, any other Affiliate of such Loan Party or to a person controlled by an Affiliate of such Loan Party; or



(ii) the Account remains unpaid more than 60 days after the original due date shown on the invoice or more than 120 days after the original invoice date; provided, there shall be excluded from such delinquent amount any credit balances relating to such Accounts with invoice dates more than 120 days prior to the date of determination; or

(iii) the total unpaid Accounts of the Account Debtor to the Loan Parties exceed 20% of all Eligible Accounts owned by the Loan Parties but only to the extent of such excess; provided, that the foregoing percentage shall be (A) 50% with respect to any Account Debtor whose securities or corporate credit are rated investment grade and (B) 25% with respect to any Account Debtor listed on Schedule 1.01(D) (which may be supplemented by the Borrower prior to the Startup Date with the consent of the Administrative Agent (not to be unreasonably withheld, delayed or conditioned)) if, in each case of this subclause (B) to the extent applicable, the securities and corporate credit of such Account Debtor are not rated investment grade; provided, further, that, in each case, the amount of Eligible Accounts that are excluded because they exceed the foregoing percentage shall be determined by the Administrative Agent based on all of the otherwise Eligible Accounts prior to giving effect to any eliminations based upon the foregoing concentration limits; or

(iv) any covenant, representation or warranty contained in this Agreement with respect to such Account has been breached in any material respect; or

(v) the Account Debtor is also a creditor or supplier of the owner of such Account, or the Account Debtor has disputed liability with respect to such Account, or the Account Debtor has made any claim with respect to any other Account due from such Account Debtor to the owner of such Account, or the Account otherwise is or may become subject to right of set-off by the Account Debtor unless, in each case, the Account Debtor has entered into an agreement with the owner of such Account reasonably acceptable to the Administrative Agent to waive such set-off rights and/or such other rights or the Administrative Agent otherwise agrees in its Reasonable Credit Judgment; provided, that any such Account shall be ineligible under this clause (v) only to the extent of such contract, dispute, claim, set-off or similar right; or

(vi) the Account Debtor (A) has commenced a voluntary case under the U.S. federal bankruptcy laws (or any other applicable insolvency laws in any jurisdiction), (B) made an assignment, composition or arrangement for the benefit of creditors, or a decree or order for relief (including by way of suspension of payments, moratorium of indebtedness and/or suspension of rights of enforcement) has been entered by a court having jurisdiction in the premises in respect of the Account Debtor in an involuntary case under the federal bankruptcy laws (or any other applicable insolvency laws in any jurisdiction) as now constituted or hereafter amended, or any other petition or other application for relief under the U.S. federal bankruptcy laws (or any other applicable insolvency laws in any jurisdiction), as now constituted or hereafter amended, has been filed against or by the Account Debtor or (C) has failed, suspended business, ceased to be solvent, or consented to or suffered a receiver, trustee, liquidator, custodian, administrator receiver or manager, administrative receiver, interim receiver, sheriff, monitor, sequestrator or similar officer or fiduciary to be appointed for it or for all or a significant portion

of its assets or affairs; provided, that (I) the Administrative Agent may, in its Reasonable Credit Judgment, include Accounts from Account Debtors subject to such proceedings if and to the extent that such Accounts are fully covered by credit insurance, letters of credit or other sufficient third-party credit support, or are otherwise deemed by the Administrative Agent not to pose an unreasonable risk of non-collectibility and (II) post-petition Accounts of an Account Debtor subject to such proceedings will be Eligible Accounts without the consent of the Administrative Agent so long as (1) such Account Debtor has received “debtor in possession” financing, (2) all Accounts that are Eligible Accounts in accordance with clause (II) of this proviso do not exceed \$500,000 in the aggregate and (3) such Accounts do not remain unpaid more than 45 days after the original due date shown on the invoice or more than 75 days after the original invoice date; or

(vii) it arises from a sale made or services rendered to an Account Debtor that is headquartered or organized outside the United States of America or Canada which (along with other similar Accounts) exceeds \$1,000,000 in the aggregate for all such Account Debtors, unless backed by a letter of credit, credit insurance, guaranty, acceptance or similar terms acceptable to the Administrative Agent in its Reasonable Credit Judgment; or

(viii) (A) it arises from a sale to the Account Debtor on a bill-and-hold, guaranteed sale, sale-or-return, sale-on-approval or any other repurchase or return basis (including any Account relating to Inventory held on consignment and not yet sold by the consignee) or (B) it is subject to a reserve established by the applicable Loan Party for potential returns or refunds, to the extent of such reserve; or

(ix) it was not paid in full, and the Borrower created a new receivable for the unpaid portion of the Account without the agreement of the customer, or it is an Account constituting a chargeback, debit memo or other adjustment for unauthorized deductions; or

(x) it is payable in any currency other than in Dollars or in Canadian Dollars; or

(xi) to the extent constituting the obligation of an Account Debtor in respect of interest, service or similar charges or fees; or

(xii) to the extent in excess of \$4,000,000 for all such Accounts, the Account Debtor is the United States of America or Canada, unless the applicable Loan Party assigns its right to payment of such Account to the Collateral Agent, in a manner satisfactory to the Administrative Agent, in its Reasonable Credit Judgment, so as to comply with the Assignment of Claims Act of 1940 (31 U.S.C. §3727, 41 U.S.C. §15 et seq.), as amended, or the Financial Administration Act (Canada), as the case may be; or

(xiii) it is not subject to the Collateral Agent’s duly perfected security interest, which shall be the only Lien to which such Account is subject other than any Permitted Lien (which Permitted Lien shall be (I) junior to the Collateral Agent’s Lien on such Account, (II) arising by operation of law as described in Section 6.02(d), (e), (k) or (r) or (III) subject to a Reserve (as determined by the Administrative Agent in its Reasonable Credit Judgment, in an aggregate amount not to exceed the amount of Indebtedness secured by such Permitted Lien)); or

(xiv) the Account is evidenced by chattel paper or an instrument of any kind, or has been reduced to judgment; or

(xv) the applicable Loan Party or a Subsidiary of the applicable Loan Party has made any agreement with the Account Debtor for any extension or material modification of the Account or deduction therefrom, (A) except for (x) discounts or allowances which are made in the ordinary course of business for prompt payment and (y) volume discounts which are made in the ordinary course of business, all of which discounts (including volume discounts) or allowances are reflected in the calculation of the face value of each invoice related to such Account and (B) except if such extension, modification or deduction is deemed by the Administrative Agent in its Reasonable Credit Judgment not to pose an unreasonable risk of non-collectibility with respect to such Account; or

(xvi) the Account is owing by any governmental, inter-governmental or super-national body, agency, crown, department or regulatory, self-regulatory or other similar authority or organization (in each case, other than with respect to the government of the United States of America or Canada with respect to which provisions of clause (xii) above are satisfied), unless backed by a letter of credit, credit insurance, guaranty, acceptance or similar terms acceptable to the Administrative Agent in its Reasonable Credit Judgment; or

(xvii) 50% or more of all Accounts owing from the Account Debtor or, to the Borrower's knowledge, from any of such Account Debtor's wholly-owned or majority-owned subsidiaries, are not Eligible Accounts hereunder by reason of applicability of clause (ii) above; provided, there shall be excluded from such delinquent amount any credit balances relating to Accounts with invoice dates more than 120 days prior to the date of determination; or

(xviii) the goods giving rise to such Account have not been delivered to and accepted by the Account Debtor or the services giving rise to such Account have not been performed by the applicable Subsidiary Loan Party and accepted by the Account Debtor or the Account otherwise does not represent a final sale by the Borrower or the applicable Subsidiary Loan Party in the ordinary course of business; or

(xix) the invoice with respect to such Account has not been sent to the applicable Account Debtor; or

(xx) the Account is an Unaudited Acquired Asset until such time as the Account is permitted to be included in accordance with the definition of "Borrowing Base".

If any Account at any time ceases to be an Eligible Account, then such Account shall promptly be excluded from the calculation of the Borrowing Base; provided, however, that if any Account ceases to be an Eligible Account because of the adjustment of or imposition of new exclusionary criteria pursuant to the succeeding paragraph, the Administrative Agent will not require exclusion of such Account from the Borrowing Base until five (5) Business Days following the date on which the Administrative Agent gives notice to the Borrower of such ineligibility.

The Administrative Agent reserves the right, at any time and from time to time after the Closing Date, to adjust any of the exclusionary criteria set forth above and to establish new criteria, in its Reasonable Credit Judgment (based on an analysis of material facts or events first occurring, or first discovered by the Administrative Agent, after the Closing Date), subject to the approval of Super Majority Lenders in the case of adjustments or new criteria which have the effect of making more credit available than would have been available based upon the criteria in effect on the Closing Date. The Administrative Agent acknowledges that as of the Closing Date it does not know of any circumstance or condition with respect to the Accounts that would require the adjustment of any of the exclusionary criteria set forth above or the imposition of any new exclusionary criteria.

“Eligible Credit Card Accounts” shall mean, as of any date of determination, Credit Card Receivables due to a Loan Party from major credit card and debit card processors (including, but not limited to, VISA, Mastercard, American Express, Diners Club, DiscoverCard, Interlink, NYCE and other recognized payment processing services reasonably acceptable to Agent) that arise in the ordinary course of business and which have been earned by performance and that are not excluded as ineligible by virtue of one or more of the criteria set forth below. None of the following shall be deemed to be Eligible Credit Card Accounts:

(i) Credit Card Receivables that have been outstanding for five (5) or more Business Days from the date of charge, or for such longer period(s) as may be approved by the Administrative Agent in its reasonable discretion except to the extent the Required Lenders revoke or limit any such longer period;

(ii) Credit Card Receivables with respect to which a Loan Party is not the owner or otherwise does not have good, valid and marketable title, free and clear of any Lien other than Liens permitted hereunder pursuant to Sections 6.02(a), (b), (d), (e), (f), (k), (r) or any Liens junior in priority to the Liens securing the Obligations hereunder;

(iii) Credit Card Receivables not subject to the Collateral Agent’s duly perfected security interest, which shall be the only Lien to which such Credit Card Receivables are subject other than any Permitted Lien (which Permitted Lien shall be (I) junior to the Collateral Agent’s Lien on such Credit Card Receivables, (II) arising by operation of law as described in Section 6.02(d), (e), (k) or (r) or (III) subject to a Reserve (as determined by the Administrative Agent in its Reasonable Credit Judgment, in an aggregate amount not to exceed the amount of Indebtedness secured by such Permitted Lien));

(iv) Credit Card Receivables which are disputed, or with respect to which a claim, counterclaim, discount, deduction, offset, chargeback or any processing fee has been asserted, by the related credit card processor (but only to the extent of such dispute, counterclaim, discount, deduction, offset chargeback or such fee) or which are not a valid, legally enforceable obligation of the applicable processor with respect thereto;

(v) Credit Card Receivables as to which the credit card processor has the right under certain circumstances to require a Loan Party to repurchase the Accounts from such credit card or debit card processor;

(vi) Credit Card Receivables arising from any private label credit card program of a Loan Party, unless acceptable to Administrative Agent in its Reasonable Credit Judgment;

(vii) Credit Card Receivables which are evidenced by chattel paper or an instrument of any kind;

(viii) Credit Card Receivables owned by credit card or debit card processor that is subject to a bankruptcy proceeding of the type described in Sections 7.01(h) or (i) or that is liquidating, dissolving or winding up its affairs; and

(ix) Credit Card Receivables due from credit card and debit card processors (other than Visa, Mastercard, American Express, Diners Club, DiscoverCard, Interlink, NYCE, Maestro, Cirrus, PLUS, MAC, STAR, Pulse, as of the date hereof, and other recognized payment processing services reasonably acceptable to Agent) which the Agent in its Reasonable Credit Judgment determines to be unlikely to be collected.

If any Account at any time ceases to be an Eligible Credit Card Account, then such Account shall promptly be excluded from the calculation of the Borrowing Base; provided, however, that if any Account ceases to be an Eligible Credit Card Account because of the adjustment of or imposition of new exclusionary criteria pursuant to the succeeding paragraph, the Administrative Agent will not require exclusion of such Account from the Borrowing Base until five (5) Business Days following the date on which the Administrative Agent gives notice to the Borrower of such ineligibility.

The Administrative Agent reserves the right, at any time and from time to time after the Closing Date, to adjust any of the exclusionary criteria set forth above and to establish new criteria, in its Reasonable Credit Judgment (based on an analysis of material facts or events first occurring, or first discovered by the Administrative Agent, after the Closing Date), subject to the approval of Super Majority Lenders in the case of adjustments or new criteria which have the effect of making more credit available than would have been available based upon the criteria in effect on the Closing Date. The Administrative Agent acknowledges that as of the Closing Date it does not know of any circumstance or condition with respect to the Accounts that would require the adjustment of any of the exclusionary criteria set forth above or the imposition of any new exclusionary criteria.

“Eligible Equipment” shall mean all Equipment of the Loan Parties reflected in the most recent Borrowing Base Certificate, except any Equipment with respect to which any of the exclusionary criteria set forth below applies (unless the Administrative Agent in its sole discretion elects to include such Equipment). No Equipment shall be Eligible Equipment if:

(i) such Equipment (excluding Equipment (A) in transit to the premises of any Loan Party or a customer of any Loan Party, (B) temporarily stored at a lay-down yard or similar premises for no longer than sixty (60) days or (C) at a repair facility for the purpose of being repaired in the ordinary course of business for no longer than sixty (60) days, thereafter for which the Administrative Agent shall have the right to establish a Reserve for the aggregate amount of payables owing to such repair facility in its Reasonable Credit Judgment) is located at

premises other than those owned and controlled by any Loan Party, except any Equipment which would otherwise be deemed Eligible Equipment that is not located at premises owned and controlled by any Loan Party may nevertheless be considered Eligible Equipment if the Administrative Agent shall have received a Collateral Access Agreement from the person in possession and control of such premises and such Equipment, duly authorized, executed and delivered by such person, or if the Administrative Agent shall not have received such Collateral Access Agreement, such Equipment will nonetheless be considered Eligible Equipment under this clause (i) but the Administrative Agent shall have the right to establish Location Reserves with respect to such Equipment; provided, however, that no Equipment owned by such Loan Party shall be ineligible solely by virtue of this clause (i) during the 90 day period following the Closing Date (it being understood that Location Reserves with respect to such Equipment may be established after such time if a Collateral Access Agreement from the person in possession and control of such premises and such Equipment, duly authorized, executed and delivered by such person, is not received by the Administrative Agent by such time); or

(ii) such Equipment is subject to a security interest or lien in favor of any person other than the Collateral Agent except for any Permitted Lien; provided that such Permitted Liens (i) are Junior Liens, (ii) arise by operation of law or (iii) are subject to Reserves established in the Administrative Agent's Reasonable Credit Judgment in an aggregate amount not to exceed the amount of liabilities secured by such Permitted Liens;

(iii) such Equipment is located outside the United States of America; or

(iv) such Equipment (other than Titled Equipment owned by a Loan Party as of the Closing Date or acquired by the Loan Parties after the Closing Date, in each case, as to which the terms of clause (vi) below shall apply) is not subject to the valid and perfected security interest of the Collateral Agent; or

(v) such Equipment is worn or obsolete or not used or usable in the ordinary course of such Loan Party's business; or

(vi) such Equipment consists of Titled Equipment with an aggregate Net Book Value of all such Titled Equipment in excess of \$2,500,000, unless, to the extent requested by the Collateral Agent in its sole discretion, within one hundred fifty (150) days (or such later date as the Administrative Agent may agree in its sole discretion) following the date of any such request, the Collateral Agent or the Collateral Agent's titling service shall have received either an original certificate of title or evidence, in form and substance reasonably acceptable to the Administrative Agent, of the recording of an electronic certificate of title, in each case relating to such Titled Equipment which reflects the Collateral Agent as the first priority lienholder in respect of such Titled Equipment in a manner reasonably satisfactory to the Administrative Agent and at all times thereafter such Equipment shall be subject to a valid and perfected security interest of the Collateral Agent; or

(vii) such Equipment consists of fixtures (as determined in accordance with local laws); or

(viii) such Equipment is purchased on consignment or being serviced, except for Equipment being serviced which remains perfected without any further action; or

(ix) such Equipment is not covered by casualty or liability insurance (subject to customary deductibles) in accordance with the terms hereof; or

(x) such Equipment is not separately identifiable from goods of third parties stored on the same premises as such Equipment; or

(xi) such Equipment is located at premises owned or leased by any Loan Party where the aggregate Net Book Value of all Eligible Equipment located at such premises is less than \$50,000.

If any Equipment at any time ceases to be an Eligible Equipment, then such Equipment shall promptly be excluded from the calculation of the Borrowing Base; provided, however, that if any Equipment ceases to be an Eligible Equipment because of the adjustment of or imposition of new exclusionary criteria pursuant to the succeeding paragraph, the Administrative Agent will not require exclusion of such Equipment from the Borrowing Base until five (5) Business Days following the date on which the Administrative Agent gives notice to the Borrower of such ineligibility.

The Administrative Agent reserves the right, at any time and from time to time after the Closing Date, to adjust any of the exclusionary criteria set forth above and to establish new criteria, in its Reasonable Credit Judgment (based on an analysis of material facts or events first occurring, or first discovered by the Administrative Agent, after the Closing Date), subject to the approval of the Super Majority Lenders in the case of adjustments or new criteria which have the effect of making more credit available than would have been available based upon the criteria in effect on the Closing Date. The Administrative Agent acknowledges that as of the Closing Date it does not know of any circumstance or condition with respect to the Equipment that would require the adjustment of any of the exclusionary criteria set forth above or the imposition of any new exclusionary criteria.

“Eligible Inventory” shall mean all Inventory of the Loan Parties reflected in the most recent Borrowing Base Certificate, except any Inventory with respect to which any of the exclusionary criteria set forth below applies (unless the Administrative Agent in its sole discretion elects to include such Inventory). No Inventory shall be Eligible Inventory if:

(i) such Inventory (x) to the extent having a Net Book Value in excess of \$8,000,000 for all such Inventory, is not subject to the Collateral Agent’s duly perfected security interest or (y) is subject to a security interest or lien in favor of any person other than the Collateral Agent except for any Permitted Lien; provided that such Permitted Liens (i) are Junior Liens, (ii) arise by operation of law or (iii) are subject to Reserves established in the Administrative Agent’s Reasonable Credit Judgment in an aggregate amount not to exceed the amount of liabilities secured by such Permitted Liens; or

(ii) such Inventory (excluding Inventory (A) in transit to the premises of any Loan Party or a customer of any Loan Party, (B) temporarily stored at a lay-down yard or similar premises for no longer than sixty (60) days or (C) at a repair facility for the purpose of being repaired in the ordinary course of business for no longer than sixty (60) days, thereafter for which the Administrative Agent shall have the right to establish a Reserve for the aggregate amount of payables owing to such repair facility in its Reasonable Credit Judgment) is located at premises other than those owned and controlled by any Loan Party, except any Inventory which would otherwise be deemed Eligible Inventory that is not located at premises owned and controlled by any Loan Party may nevertheless be considered Eligible Inventory if the Administrative Agent shall have received a Collateral Access Agreement from the person in possession and control of such premises and such Inventory, duly authorized, executed and delivered by such person, or if the Administrative Agent shall not have received such Collateral Access Agreement, such Inventory will nonetheless be considered Eligible Inventory under this clause (i) but the Administrative Agent shall have the right to establish Location Reserves with respect to such Inventory; provided, however, that no Inventory owned by such Loan Party shall be ineligible solely by virtue of this clause (i) during the 90 day period following the Closing Date (it being understood that Location Reserves with respect to such Inventory may be established after such time if a Collateral Access Agreement from the person in possession and control of such premises and such Inventory, duly authorized, executed and delivered by such person, is not received by the Administrative Agent by such time); or

(iii) such Inventory is located outside the United States of America; or

(iv) such Inventory is worn or obsolete or not used or usable; or

(v) such Inventory consists of fixtures (as determined in accordance with local laws); or

(vi) such Inventory is purchased on consignment or being serviced, except for Inventory being serviced which remains perfected without any further action; or

(vii) such Inventory is not covered by casualty or liability insurance (subject to customary deductibles) in accordance with the terms hereof; or

(viii) such Inventory is not separately identifiable from goods of third parties stored on the same premises as such Inventory.

If any Inventory at any time ceases to be Eligible Inventory, such Inventory shall promptly be excluded from the calculation of the Borrowing Base; provided, however, that if any Inventory ceases to be Eligible Inventory because of the adjustment of or imposition of new exclusionary criteria pursuant to the succeeding paragraph, the Administrative Agent will not require exclusion of such Inventory from the Borrowing Base until five (5) Business Days following the date on which the Administrative Agent gives notice to the Borrower of such ineligibility.



The Administrative Agent reserves the right, at any time and from time to time after the Closing Date, to adjust any of the exclusionary criteria set forth above and to establish new criteria, in its Reasonable Credit Judgment (based on an analysis of material facts or events first occurring, or first discovered by the Administrative Agent, after the Closing Date), subject to the approval of the Super Majority Lenders in the case of adjustments or new criteria which have the effect of making more credit available than would have been available based upon the criteria in effect on the Closing Date. The Administrative Agent acknowledges that as of the Closing Date it does not know of any circumstance or condition with respect to the Inventory that would require the adjustment of any of the exclusionary criteria set forth above or the imposition of any new exclusionary criteria.

“Environment” shall mean ambient and indoor air, surface water and groundwater (including potable water, navigable water and wetlands), the land surface or subsurface strata, natural resources such as flora and fauna, the workplace or as otherwise defined in any Environmental Law.

“Environmental Laws” shall mean all applicable laws (including common law), rules, regulations, codes, ordinances, orders, binding agreements, decrees or judgments, promulgated or entered into by or with any Governmental Authority, relating in any way to the environment, preservation or reclamation of natural resources, the generation, use, transport, management, Release or threatened Release of, or exposure to, any hazardous material or to public or employee health and safety matters (to the extent relating to the environment or hazardous materials).

“Environmental Permits” shall have the meaning assigned to such term in Section 3.16.

“Equipment” shall mean, as to each Loan Party, all of such Loan Party’s now owned and hereafter acquired equipment, wherever located, including machinery, data processing and computer equipment (whether owned or leased and including embedded software that is licensed as part of such computer equipment), telephones, vehicles, Ground Service Equipment, Flight Simulators, inflight equipment, office equipment, rolling stock, tools, furniture, maintenance equipment, kitchen equipment, fixtures, all attachments, accessions and property now or hereafter affixed thereto or used in connection therewith, and substitutions and replacements thereof, wherever located (but excluding Spare Parts and, for the avoidance of doubt, aircraft and aircraft engines).

“Equity Financing” shall have the meaning assigned to such term in Section 4.03(f).

“Equity Interests” of any person shall mean any and all shares, interests, rights to purchase or otherwise acquire, warrants, options, participations or other equivalents of or interests in (however designated) equity or ownership of such person, including any preferred stock, any limited or general partnership interest and any limited liability company interest, and any securities or other rights or interests convertible into or exchangeable for any of the foregoing.

“ERISA” shall mean the Employee Retirement Income Security Act of 1974, as the same may be amended from time to time and any final regulations promulgated and the rulings issued thereunder.

“ERISA Affiliate” shall mean any trade or business (whether or not incorporated) that, together with Holdings, the Borrower or a Subsidiary, is treated as a single employer under Section 414(b) or (c) of the Code, or, solely for purposes of Section 302 of ERISA and Section 412 of the Code, is treated as a single employer under Section 414 of the Code.

“ERISA Event” shall mean (a) any Reportable Event or the requirements of Section 4043(b) of ERISA apply with respect to a Plan; (b) with respect to any Plan, the failure to satisfy the minimum funding standard under Section 412 of the Code or Section 302 of ERISA, whether or not waived; (c) a determination that any Plan is, or is expected to be, in “at-risk” status (as defined in Section 303(i)(4) of ERISA or Section 430(i)(4) of the Code); (d) the filing pursuant to Section 412(c) of the Code or Section 302(c) of ERISA of an application for a waiver of the minimum funding standard with respect to any Plan, the failure to make by its due date a required installment under Section 430(j) of the Code with respect to any Plan or the failure to make any required contribution to a Multiemployer Plan; (e) the incurrence by Holdings, the Borrower, a Subsidiary or any ERISA Affiliate of any liability under Title IV of ERISA with respect to the termination of any Plan or Multiemployer Plan; (f) the receipt by Holdings, the Borrower, a Subsidiary or any ERISA Affiliate from the PBGC or a plan administrator of any notice relating to an intention to terminate any Plan or to appoint a trustee to administer any Plan under Section 4042 of ERISA; (g) the incurrence by Holdings, the Borrower, a Subsidiary or any ERISA Affiliate of any liability with respect to the withdrawal or partial withdrawal from any Plan or Multiemployer Plan; (h) the receipt by Holdings, the Borrower, a Subsidiary or any ERISA Affiliate of any notice, or the receipt by any Multiemployer Plan from Holdings, the Borrower, a Subsidiary or any ERISA Affiliate of any notice, concerning the impending imposition of Withdrawal Liability or a determination that a Multiemployer Plan is, or is expected to be, insolvent or in reorganization, within the meaning of Title IV of ERISA, or in “endangered” or “critical” status, within the meaning of Section 432 of the Code or Section 305 of ERISA; (i) the conditions for imposition of a lien under Section 303(k) of ERISA shall have been met with respect to any Plan; or (j) the withdrawal of any of Holdings, the Borrower, a Subsidiary or any ERISA Affiliate from a Plan subject to Section 4063 of ERISA during a plan year in which such entity was a “substantial employer” as defined in Section 4001(a)(2) of ERISA or a cessation of operations that is treated as such a withdrawal under Section 4062(e) of ERISA.

“Eurocurrency Borrowing” shall mean a Borrowing comprised of Eurocurrency Loans.

“Eurocurrency Loan” shall mean any Revolving Loan bearing interest at a rate determined by reference to the Adjusted LIBOR Rate in accordance with the provisions of Article II.

“Event of Default” shall have the meaning assigned to such term in Section 7.01.

“Exchange Act” shall mean the Securities Exchange Act of 1934, as amended.

“Excluded Deposit Accounts” shall mean accounts solely holding withheld income taxes, payroll taxes or other employment-related taxes or amounts to be paid over to employee health or benefits plans and, in each case, funded in the ordinary course of business.

“Excluded Property” shall have the meaning assigned to such term in Section 5.10(g).

“Excluded Securities” shall mean any of the following:

(a) any Equity Interests or Indebtedness with respect to which the Collateral Agent and the Borrower reasonably agree that the cost or other consequences of pledging such Equity Interests or Indebtedness in favor of the Secured Parties under the Security Documents are likely to be excessive in relation to the value to be afforded thereby;

(b) in the case of any pledge of voting Equity Interests of any Foreign Subsidiary (in each case, that is owned directly by the Borrower or a Subsidiary Loan Party) to secure the Obligations, any voting Equity Interest of such Foreign Subsidiary in excess of 65% of the outstanding voting Equity Interests of such class;

(c) in the case of any pledge of voting Equity Interests of any FSHCO (in each case, that is owned directly by the Borrower or a Subsidiary Loan Party) to secure the Obligations, any voting Equity Interest of such FSHCO in excess of 65% of the outstanding voting Equity Interests of such class;

(d) any Equity Interests or Indebtedness to the extent the pledge thereof would be prohibited by any Requirement of Law;

(e) any Equity Interests of any person that is not a Wholly Owned Subsidiary of such person to the extent (A) that a pledge thereof to secure the Obligations is prohibited by (i) any applicable organizational documents, joint venture agreement or shareholder agreement or (ii) any other contractual obligation with an unaffiliated third party not in violation of Section 6.09(c) (other than, in this subclause (A)(ii), customary non-assignment provisions which are ineffective under Article 9 of the Uniform Commercial Code or other applicable Requirements of Law), (B) any organizational documents, joint venture agreement or shareholder agreement (or other contractual obligation referred to in subclause (A)(ii) above) of such person prohibits such a pledge without the consent of any other party; provided, that this clause (B) shall not apply if (1) such other party is a Loan Party or a Wholly Owned Subsidiary of a Loan Party or (2) consent has been obtained to consummate such pledge (it being understood that the foregoing shall not be deemed to obligate the Borrower or any Subsidiary to obtain any such consent) and this clause (B) shall only apply for so long as such organizational documents, joint venture agreement or shareholder agreement or replacement or renewal thereof is in effect, or (C) a pledge thereof to secure the Obligations would give any other party (other than a Loan Party or a Wholly Owned Subsidiary of a Loan Party) to any organizational documents, joint venture agreement or shareholder agreement governing such Equity Interests (or other contractual obligation referred to in subclause (A)(ii) above) the right to terminate its obligations thereunder (other than, in the case of other contractual obligations referred to in subclause (A)(ii), customary non-assignment provisions which are ineffective under Article 9 of the Uniform Commercial Code or other applicable Requirement of Law);

(f) any Equity Interests of any Immaterial Subsidiary or any Unrestricted Subsidiary;

(g) any Equity Interests of any subsidiary of, or other Equity Interests owned by, a Foreign Subsidiary;

(h) any Equity Interests of any Subsidiary to the extent that the pledge of such Equity Interests could reasonably be expected to result in material adverse tax consequences to the Borrower or any Subsidiary as determined in good faith by the Borrower;

(i) any Equity Interests that are set forth on Schedule 1.01(A) to this Agreement or that have been identified on or prior to the Closing Date in writing to the Agent by a Responsible Officer of the Borrower and agreed to by the Administrative Agent;

(j) (x) any Equity Interests owned by Holdings, other than Equity Interests in the Borrower and (y) any Indebtedness owned by Holdings;  
and

(k) any Margin Stock.

“Excluded Subsidiary” shall mean any of the following (except as otherwise provided in clause (b) of the definition of Subsidiary Loan Party):

(a) each Immaterial Subsidiary,

(b) each Domestic Subsidiary that is not a Wholly Owned Subsidiary (for so long as such Subsidiary remains a non-Wholly Owned Subsidiary),

(c) each Domestic Subsidiary that is prohibited from guaranteeing or granting Liens to secure the Obligations by any Requirement of Law or that would require consent, approval, license or authorization of a Governmental Authority to guarantee or grant Liens to secure the Obligations (unless such consent, approval, license or authorization has been received),

(d) each Domestic Subsidiary that is prohibited by any applicable contractual requirement from guaranteeing or granting Liens to secure the Obligations on the Closing Date or at the time such Subsidiary becomes a Subsidiary not in violation of Section 6.09(c) (and for so long as such restriction or any replacement or renewal thereof is in effect),

(e) any Foreign Subsidiary,

(f) any Domestic Subsidiary (i) that is an FSHCO or (ii) that is a Subsidiary of a Foreign Subsidiary that is a CFC,

(g) any other Domestic Subsidiary with respect to which, (x) the Administrative Agent and the Borrower reasonably agree that the cost or other consequences of providing a Guarantee of or granting Liens to secure the Obligations are likely to be excessive in relation to the value to be afforded thereby or (y) providing such a Guarantee or granting such Liens could reasonably be expected to result in material adverse tax consequences as determined in good faith by the Borrower,

(h) each Unrestricted Subsidiary, and

(i) with respect to any Swap Obligation, any Subsidiary that is not an “eligible contract participant” as defined in the Commodity Exchange Act and the regulations thereunder.

“Excluded Swap Obligation” shall mean, with respect to any Guarantor, any Swap Obligation if, and to the extent that, all or a portion of the Guarantee of such Guarantor of, or the grant by such Guarantor of a security interest to secure, such Swap Obligation (or any Guarantee thereof) is or becomes illegal under the Commodity Exchange Act or any rule, regulation or order of the Commodity Futures Trading Commission (or the application or official interpretation of any thereof) by virtue of such Guarantor’s failure for any reason to constitute an “eligible contract participant” as defined in the Commodity Exchange Act and the regulations thereunder at the time the Guarantee of such Guarantor or the grant of such security interest becomes effective with respect to such Swap Obligation, unless otherwise agreed between the Borrower and the Administrative Agent. If a Swap Obligation arises under a master agreement governing more than one swap, such exclusion shall apply only to the portion of such Swap Obligation that is attributable to swaps for which such Guarantee or security interest is or becomes illegal.

“Excluded Taxes” shall mean, with respect to the Administrative Agent, any Lender or any other recipient of any payment to be made by or on account of any obligation of any Loan Party hereunder or under any other Loan Document, (i) Taxes imposed on or measured by its overall net income or branch profits (however denominated, and including (for the avoidance of doubt) any backup withholding in respect thereof under Section 3406 of the Code or any similar provision of state, local or foreign law), and franchise (and similar) Taxes imposed on it (in lieu of net income Taxes), in each case by a jurisdiction (including any political subdivision thereof) as a result of such recipient being organized in, having its principal office in, or in the case of any Lender, having its applicable lending office in, such jurisdiction, or as a result of any other present or former connection with such jurisdiction (other than any such connection arising solely from this Agreement or any other Loan Documents or any transactions contemplated thereunder), (ii) U.S. federal withholding Tax imposed on any payment by or on account of any obligation of any Loan Party hereunder or under any other Loan Document that is required to be imposed on amounts payable to a Lender (other than to the extent such Lender is an assignee pursuant to a request by the Borrower under Section 2.16(b) or 2.16(c)) pursuant to laws in force at the time such Lender becomes a party hereto (or designates a new lending office), except to the extent that such Lender (or its assignor, if any) was entitled, immediately prior to the designation of a new lending office (or assignment), to receive additional amounts or indemnification payments from any Loan Party with respect to such withholding Tax pursuant to Section 2.14 and (iii) any withholding Tax imposed on any payment by or on account of any obligation of any Loan Party hereunder or under any other Loan Document that is attributable to the Administrative Agent’s, any Lender’s or any other recipient’s failure to comply with Section 2.17(d) or (e) or (iv) any Tax imposed under FATCA.

“Exempted Accounts” shall have the meaning assigned to such term in Section 5.11(h).

“Existing Credit Facility” shall mean the Credit Agreement, dated November 7, 2012, among the Borrower, BMO Harris Bank N.A., as agent, and the other parties party thereto, as amended by the First through Fifth Amendments dated September 30, 2013, June 30, 2015, September 2016, June 30, 2017 and July 21, 2017, and as further amended, restated, supplemented or otherwise modified from time to time.

“Extended Revolving Commitment” shall have the meaning assigned to such term in Section 2.21(e).

“Extended Revolving Loans” shall have the meaning assigned to such term in Section 2.21(e).

“Extending Lender” shall have the meaning assigned to such term in Section 2.21(e).

“Extension” shall have the meaning assigned to such term in Section 2.21(e).

“FAA” shall mean the Federal Aviation Administration of the United States of America and any successor thereto.

“Facility” shall mean the respective facility and commitments utilized in making Loans and credit extensions hereunder, it being understood that, as of the Closing Date, there is one Facility (*i.e.*, the Revolving Facility Commitments established on the Closing Date and the extensions of credit thereunder), and thereafter, the term “Facility” may include any other Class of Incremental Commitments and the extensions of credit thereunder.

“Facility Termination Event” shall have the meaning assigned to such term in Section 2.05(k).

“FATCA” shall mean Sections 1471 through 1474 of the Code, as of the date of this Agreement (or any amended or successor version that is substantively comparable and not materially more onerous to comply with), any Treasury regulations promulgated thereunder or official administrative interpretations thereof, any agreements entered into pursuant to Section 1471(b)(1) of the Code and any fiscal or regulatory legislation, rules or practices adopted pursuant to any intergovernmental agreement, treaty or convention among Governmental Authorities entered into in connection with the implementation of such Sections of the Code.

“Federal Funds Effective Rate” shall mean, for any day, the rate calculated by the Federal Reserve Bank of New York based on such day’s federal funds transactions by depository institutions (as determined in such manner as the Federal Reserve Bank of New York shall set forth on its public website from time to time) and published on the next succeeding Business Day by the Federal Reserve Bank of New York as the federal funds effective rate.

“Fee Letter” shall mean that certain Fee Letter dated as of December 13, 2017 by and among Holdings and the Administrative Agent.

“Fees” shall mean the Commitment Fees, the L/C Participation Fees, the Issuing Bank Fees and the Administrative Agent Fees.

“Financial Officer” of any person shall mean the Chief Financial Officer, principal accounting officer, Treasurer, Assistant Treasurer or Controller of such person.

“Financial Performance Covenant” shall mean the covenant of the Borrower set forth in Section 6.10.

“Fixed Charge Coverage Ratio” shall mean on any date the ratio of (a) (i) EBITDAR for the Test Period most recently ended as of such date minus (ii) after the Startup Date, non-financed Capital Expenditures of the Borrower and its Subsidiaries paid in cash during such period (including such expenditures financed with proceeds of the Revolving Loans) minus (iii) cash income taxes paid by the Borrower and its Subsidiaries during such period to (b) the sum of (i) scheduled principal payments required to be made during such period in respect of Indebtedness for borrowed money by the Borrower and its Subsidiaries plus (ii) the Cash Interest Expense for such period plus (iii) Restricted Payments pursuant to Section 6.06(c), (e) or (h), in each case to the extent paid by the Borrower in cash for such period (excluding items eliminated in consolidation) plus (iv) all rent expense, which for the avoidance of doubt shall include engine rent expense otherwise reported as a component of maintenance expense, for such period; provided, that the Fixed Charge Coverage Ratio shall be determined for the relevant Test Period on a Pro Forma Basis.

“Flight Simulators” shall mean the flight simulators and flight training devices owned by any Loan Party.

“Flood Documentation” shall mean, with respect to each Mortgaged Property located in the United States of America or any territory thereof, (i) a completed “life-of-loan” Federal Emergency Management Agency standard flood hazard determination (to the extent a Mortgaged Property is located in a Special Flood Hazard Area, together with a notice about Special Flood Hazard Area status and flood disaster assistance duly executed by the Borrower and the applicable Loan Party relating thereto) and (ii) a copy of, or a certificate as to coverage under, and a declaration page relating to, the insurance policies required by Section 5.02(b) hereof and the applicable provisions of the Security Documents, each of which shall (A) be endorsed or otherwise amended to include a “standard” or “New York” lender’s loss payable or mortgagee endorsement (as applicable), (B) name the Collateral Agent, on behalf of the Secured Parties, as additional insured and loss payee/mortgagee, (C) identify the address of each property located in a Special Flood Hazard Area, the applicable flood zone designation and the flood insurance coverage and deductible relating thereto and (D) be otherwise in form and substance reasonably satisfactory to the Collateral Agent.

“Flood Insurance Laws” shall mean, collectively, (i) the National Flood Insurance Act of 1968 as now or hereafter in effect or any successor statute thereto, (ii) the Flood Disaster Protection Act of 1973 as now or hereafter in effect or any successor statute thereto, (iii) the National Flood Insurance Reform Act of 1994 as now or hereafter in effect or any successor statute thereto, (iv) the Flood Insurance Reform Act of 2004 as now or hereafter in effect or any successor statute thereto and (v) the Biggert-Waters Flood Insurance Reform Act of 2012 as now or hereafter in effect or any successor statute thereto.

“Foreign Lender” shall mean any Lender (a) that is not disregarded as separate from its owner for U.S. federal income tax purposes and that is not a “United States person” as defined by Section 7701(a)(30) of the Code or (b) that is disregarded as separate from its owner for U.S. federal income tax purposes and whose regarded owner is not a “United States person” as defined in Section 7701(a)(30) of the Code.

“Foreign Subsidiary” shall mean any Subsidiary that is incorporated or organized under the laws of any jurisdiction other than the United States of America, any state thereof or the District of Columbia.

“Fronting Exposure” shall mean, at any time there is a Defaulting Lender, (a) with respect to any Issuing Bank, such Defaulting Lender’s Revolving Facility Percentage of Revolving L/C Exposure with respect to Letters of Credit issued by such Issuing Bank other than such Revolving L/C Exposure as to which such Defaulting Lender’s participation obligation has been reallocated to other Lenders or Cash Collateralized in accordance with the terms hereof and (b) with respect to the Swingline Lender, such Defaulting Lender’s Swingline Exposure other than Swingline Loans as to which such Defaulting Lender’s participation obligation has been reallocated to other Lenders.

“FSHCO” shall mean any Subsidiary that owns no material assets other than the Equity Interests of one or more Foreign Subsidiaries that are CFCs and/or of one or more FSHCOs.

“Fund” shall mean, collectively, investment funds managed by Affiliates of Apollo Global Management, LLC.

“Fund Affiliate” shall mean (i) each Affiliate of the Fund that is neither a “portfolio company” (which means a company actively engaged in providing goods or services to unaffiliated customers), whether or not controlled, nor a company controlled by a “portfolio company” and (ii) any individual who is a partner or employee of Apollo Management, L.P. or Apollo Management VIII, L.P.

“GAAP” shall mean generally accepted accounting principles in effect from time to time in the United States of America, applied on a consistent basis, subject to the provisions of Section 1.02; provided, that any reference to the application of GAAP in Sections 3.12(b), 3.19, 5.03, 5.07 and 6.02(e) to a Foreign Subsidiary (and not as a consolidated Subsidiary of the Borrower) shall mean generally accepted accounting principles in effect from time to time in the jurisdiction of organization of such Foreign Subsidiary.

“Governmental Authority” shall mean any federal, state, local or foreign court or governmental agency, authority, instrumentality or regulatory or legislative body.



“Ground Service Equipment” shall mean the ground service equipment, de-icers, ground support equipment, aircraft cleaning devices, materials handling equipment, passenger walkways and other similar equipment owned by any Loan Party.

“Guarantee” of or by any person (the “guarantor”) shall mean (a) any obligation, contingent or otherwise, of the guarantor guaranteeing or having the economic effect of guaranteeing any Indebtedness or other monetary obligation payable or performable by another person (the “primary obligor”) in any manner, whether directly or indirectly, and including any obligation of the guarantor, direct or indirect, (i) to purchase or pay (or advance or supply funds for the purchase or payment of) such Indebtedness or other obligation, (ii) to purchase or lease property, securities or services for the purpose of assuring the owner of such Indebtedness or other obligation of the payment thereof, (iii) to maintain working capital, equity capital or any other financial statement condition or liquidity of the primary obligor so as to enable the primary obligor to pay such Indebtedness or other obligation or (iv) entered into for the purpose of assuring in any other manner the holders of such Indebtedness or other obligation of the payment thereof or to protect such holders against loss in respect thereof (in whole or in part), or (b) any Lien on any assets of the guarantor securing any Indebtedness or other obligation (or any existing right, contingent or otherwise, of the holder of Indebtedness or other obligation to be secured by such a Lien) of any other person, whether or not such Indebtedness or other obligation is assumed by the guarantor; provided, however, that the term “Guarantee” shall not include endorsements of instruments for deposit or collection in the ordinary course of business or customary and reasonable indemnity obligations in effect on the Closing Date or entered into in connection with any acquisition or Disposition of assets permitted by this Agreement (other than such obligations with respect to Indebtedness). The amount of any Guarantee shall be deemed to be an amount equal to the stated or determinable amount of the Indebtedness in respect of which such Guarantee is made or, if not stated or determinable, the maximum reasonably anticipated liability in respect thereof as determined by such person in good faith.

“Guarantee Agreement” shall mean the Guarantee (ABL Facility), substantially in the form of Exhibit N, between each Subsidiary Loan Party (if any) and the Collateral Agent, as amended, restated, supplemented or otherwise modified from time to time.

“guarantor” shall have the meaning assigned to such term in the definition of the term “Guarantee”.

“Guarantors” shall mean the Loan Parties other than the Borrower.

“Hazardous Materials” shall mean all pollutants, contaminants, wastes, chemicals, materials, substances and constituents, including, without limitation, explosive or radioactive substances or petroleum by products or petroleum distillates, asbestos or asbestos-containing materials, polychlorinated biphenyls, radon gas or pesticides, fungicides, fertilizers or other agricultural chemicals, of any nature subject to regulation or which can give rise to liability under any Environmental Law.

“Hedge Bank” shall mean any person that, at the time it enters into a Hedging Agreement (or on the Closing Date), is an Agent, an Arranger, a Lender or an Affiliate of any such person, in each case of the foregoing, in its capacity as a party to such Hedging Agreement.

“Hedge Termination Value” shall mean, in respect of any one or more Hedging Agreements, after taking into account the effect of any legally enforceable netting agreement relating to such Hedging Agreements, (a) for any date on or after the date such Hedging Agreements have been closed out and termination value(s) determined in accordance therewith, such termination value(s), and (b) for any date prior to the date referenced in clause (a), the amount(s) determined as the mark-to-market value(s) for such Hedging Agreements, as determined by the counterparty thereto in accordance with the terms thereof and in accordance with customary methods for calculating mark-to-market values under similar arrangements by such counterparty.

“Hedging Agreement” shall mean any agreement with respect to any swap, forward, future or derivative transaction, or option or similar agreement involving, or settled by reference to, one or more rates, currencies, commodities, equity or debt instruments or securities, or economic, financial or pricing indices or measures of economic, financial or pricing risk or value, or credit spread transaction, repurchase transaction, reserve repurchase transaction, securities lending transaction, weather index transaction, spot contracts, fixed price physical delivery contracts, or any similar transaction or any combination of these transactions, in each case of the foregoing, whether or not exchange traded; provided, that no phantom stock or similar plan providing for payments only on account of services provided by current or former directors, officers, employees or consultants of Holdings, the Borrower or any of the Subsidiaries shall be a Hedging Agreement.

“Holdings” shall have the meaning assigned to such term in the introductory paragraph of this Agreement.

“Holdings Guarantee and Pledge Agreement” shall mean the Holdings Guarantee and Pledge Agreement (ABL Facility), substantially in the form of Exhibit O, between Holdings and the Collateral Agent, as amended, restated, supplemented or otherwise modified from time to time.

“Hypothetical Tax Rate” shall mean for any given taxable period, the highest hypothetical combined U.S. federal, state and local tax rates for an individual or corporation resident in the City and the State of New York, taking into account the deductibility of state and local income taxes as applicable at the time for United States federal income tax purposes.

“Immaterial Subsidiary” shall mean any Subsidiary that (a) did not, as of the last day of the fiscal quarter of the Borrower most recently ended for which financial statements have been (or were required to be) delivered pursuant to Section 5.04(a) or Section 5.04(b), have assets with a value in excess of 5.0% of the Consolidated Total Assets or revenues representing in excess of 5.0% of total revenues of the Borrower and the Subsidiaries on a consolidated basis as of such date, and (b) taken together with all Immaterial Subsidiaries as of such date, did not have assets with a value in excess of 10% of Consolidated Total Assets or revenues representing in excess of 10% of total revenues of the Borrower and the Subsidiaries on a consolidated basis as of such date; provided, that the Borrower may elect in its sole discretion to exclude as an Immaterial Subsidiary any Subsidiary that would otherwise meet the definition thereof. Each Immaterial Subsidiary as of the Closing Date shall be set forth in Schedule 1.01(C), and the Borrower shall update such Schedule from time to time after the Closing Date as necessary to reflect all Immaterial Subsidiaries at such time (the selection of Subsidiaries to be added to or removed from such Schedule to be made as the Borrower may determine).

“Increased Amount” of any Indebtedness shall mean any increase in the amount of such Indebtedness in connection with any accrual of interest, the accretion of accreted value, the amortization of original issue discount, the payment of interest in the form of additional Indebtedness or in the form of common stock of the Borrower, the accretion of original issue discount or liquidation preference and increases in the amount of Indebtedness outstanding solely as a result of fluctuations in the exchange rate of currencies.

“Incremental Amount” shall mean, at any time, \$10,000,000.

“Incremental Assumption Agreement” shall mean an Incremental Assumption Agreement in form and substance reasonably satisfactory to the Administrative Agent, among the Borrower, the Administrative Agent and, if applicable, one or more Lenders with Incremental Commitments.

“Incremental Commitment” shall mean, with respect to each Lender, such Lender’s commitment to make Incremental Revolving Facility Loans and/or Extended Revolving Loans.

“Incremental Revolving Commitment” shall mean the commitment of any Lender, established pursuant to Section 2.21(a), to make Incremental Revolving Facility Loans to the Borrower.

“Incremental Revolving Facility Loans” shall have the meaning assigned to such term in Section 2.21(a).

“Incremental Revolving Lender” shall mean a Lender with an Incremental Revolving Commitment or an outstanding Revolving Loan as a result of an Incremental Revolving Commitment.

“Indebtedness” of any person shall mean, if and to the extent (other than with respect to clause (i)) the same would constitute indebtedness or a liability in accordance with GAAP, without duplication, (a) all obligations of such person for borrowed money, (b) all obligations of such person evidenced by bonds, debentures, notes or similar instruments, (c) all obligations of such person under conditional sale or other title retention agreements relating to property or assets purchased by such person, (d) all obligations of such person issued or assumed as the deferred purchase price of property or services (other than such obligations accrued in the ordinary course), to the extent that the same would be required to be shown as a long term liability on a balance sheet prepared in accordance with GAAP, (e) all Capitalized Lease Obligations of such person, (f) all net payments that such person would have to make in the event of an early termination, on the date Indebtedness of such person is being determined, in respect of outstanding Hedging Agreements, (g) the principal component of all obligations, contingent or otherwise, of such person as an account party in respect of letters of credit, (h) the principal component of all obligations of such person in respect of bankers’ acceptances, (i) all Guarantees by such person of Indebtedness described in clauses (a) to (h) above and (j) the

amount of all obligations of such person with respect to the redemption, repayment or other repurchase of any Disqualified Stock (excluding accrued dividends that have not increased the liquidation preference of such Disqualified Stock); provided, that Indebtedness shall not include (A) trade and other ordinary-course payables, accrued expenses and intercompany liabilities arising in the ordinary course of business, (B) prepaid or deferred revenue, (C) purchase price holdbacks arising in the ordinary course of business in respect of a portion of the purchase prices of an asset to satisfy unperformed obligations of the seller of such asset, (D) earn-out obligations until such obligations become a liability on the balance sheet of such person in accordance with GAAP, or (E) in the case of the Borrower and the Subsidiaries, (I) all intercompany Indebtedness having a term not exceeding 364 days (inclusive of any roll-over or extensions of terms) and made in the ordinary course of business and (II) intercompany liabilities in connection with the cash management, tax and accounting operations of the Borrower and the Subsidiaries. The Indebtedness of any person shall include the Indebtedness of any partnership in which such person is a general partner, other than to the extent that the instrument or agreement evidencing such Indebtedness limits the liability of such person in respect thereof.

“Indemnified Taxes” shall mean all Taxes imposed on or with respect to or measured by any payment by or on account of any obligation of any Loan Party hereunder or under any other Loan Document other than (a) Excluded Taxes and (b) Other Taxes.

“Indemnitee” shall have the meaning assigned to such term in Section 9.05(b).

“Ineligible Institution” shall mean the persons identified in writing to the Administrative Agent by Holdings on or prior to the Effective Date, and as may be identified in writing to the Administrative Agent by Holdings or the Borrower from time to time thereafter, with the consent of the Administrative Agent (not to be unreasonably withheld or delayed), by delivery of a notice thereof to the Administrative Agent setting forth such person or persons (or the person or persons previously identified to the Administrative Agent that are to be no longer considered “Ineligible Institutions”).

“Information” shall have the meaning assigned to such term in Section 3.14(a).

“Initial Borrowing Base Certificate Date” shall mean the date on which the initial Borrowing Base Certificate is delivered (which shall be no later (but may, at the Borrower’s discretion, earlier) than the Startup Date).

“Initial Revolving Facility Commitment” shall mean, with respect to each Lender, such Lender’s commitment to make Initial Revolving Facility Loans.

“Initial Revolving Facility Loans” shall have the meaning assigned to such term in Section 2.21(a).

“Intellectual Property” shall have the meaning assigned to such term in the Collateral Agreement.

“Interest Election Request” shall mean a request by the Borrower to convert or continue a Borrowing in accordance with Section 2.07.

“Interest Expense” shall mean, with respect to any person for any period, the sum of (a) gross interest expense of such person for such period on a consolidated basis, including (i) the amortization of debt discounts, (ii) the amortization of all fees (including fees with respect to Hedging Agreements) payable in connection with the incurrence of Indebtedness to the extent included in interest expense and (iii) the portion of any payments or accruals with respect to Capitalized Lease Obligations allocable to interest expense and (b) capitalized interest of such person. For purposes of the foregoing, gross interest expense shall be determined after giving effect to any net payments made or received and costs incurred by the Borrower and the Subsidiaries with respect to Hedging Agreements, and interest on a Capitalized Lease Obligation shall be deemed to accrue at an interest rate reasonably determined by the Borrower to be the rate of interest implicit in such Capitalized Lease Obligation in accordance with GAAP.

“Interest Payment Date” shall mean, (a) with respect to any Eurocurrency Loan, (i) the last day of the Interest Period applicable to the Borrowing of which such Loan is a part, (ii) in the case of a Eurocurrency Borrowing with an Interest Period of more than three months’ duration, each day that would have been an Interest Payment Date had successive Interest Periods of three months’ duration been applicable to such Borrowing and (iii) in addition, the date of any refinancing or conversion of such Borrowing with or to a Borrowing of a different Type or the date of repayment or prepayment in accordance with Section 2.11, (b) with respect to any ABR Loan, the last Business Day of each calendar quarter and (c) with respect to any Swingline Loan, the day that such Swingline Loan is required to be repaid pursuant to Section 2.09.

“Interest Period” shall mean, as to any Eurocurrency Borrowing, the period commencing on the date of such Borrowing or on the last day of the immediately preceding Interest Period applicable to such Borrowing, as applicable, and ending on the numerically corresponding day (or, if there is no numerically corresponding day, on the last day) in the calendar month that is 1, 2, 3 or 6 months thereafter (or 12 months, if at the time of the relevant Borrowing, all Lenders make interest periods of such length available or, if agreed to by the Administrative Agent, any shorter period), as the Borrower may elect; provided, however, that if any Interest Period would end on a day other than a Business Day, such Interest Period shall be extended to the next succeeding Business Day unless such next succeeding Business Day would fall in the next calendar month, in which case such Interest Period shall end on the next preceding Business Day. Interest shall accrue from and including the first day of an Interest Period to but excluding the last day of such Interest Period.

“Interpolated Rate” means, in relation to LIBOR, the rate which results from interpolating on a linear basis between:

- (a) the applicable LIBOR for the longest period (for which that LIBOR is available) which is less than the Interest Period of that Loan; and
- (b) the applicable LIBOR for the shortest period (for which that LIBOR is available) which exceeds the Interest Period of that Loan,

each as of approximately 11:00 a.m. (London, England time) two Business Days prior to the commencement of such Interest Period of that Loan.

“Inventory” shall mean, with respect to a person, all of such person’s now owned and hereafter acquired Spare Parts.

“Investment” shall have the meaning assigned to such term in Section 6.04.

“Issuing Bank” shall mean (i) the Administrative Agent and (ii) each other Issuing Bank designated pursuant to Section 2.05(l), in each case in its capacity as an issuer of Letters of Credit hereunder, and its successors in such capacity as provided in Section 2.05(i). An Issuing Bank may, in its discretion, arrange for one or more Letters of Credit to be issued by Affiliates of such Issuing Bank, in which case the term “Issuing Bank” shall include any such Affiliate with respect to Letters of Credit issued by such Affiliate. For the avoidance of doubt, neither Barclays Bank PLC nor any of its branches, Affiliates or subsidiaries shall be required to issue any trade or commercial Letter or Credit.

“Issuing Bank Fees” shall have the meaning assigned to such term in Section 2.12(b).

“Judgment Currency” shall have the meaning assigned to such term in Section 9.19.

“Junior or Specified Financing” shall mean (a) any preferred Equity Interests, (b) any Disqualified Stock, (c) any Indebtedness that is subordinated in right of payment to the Loan Obligations and (d) Indebtedness for borrowed money secured by Liens on the Collateral that are junior to the Liens securing the Loan Obligations or unsecured Indebtedness for borrowed money, in each case of this clause (d), incurred pursuant to Section 6.01(r).

“Latest Maturity Date” shall mean, at any date of determination, the latest Maturity Date with respect to Revolving Commitments (including Revolving Commitments resulting from extending Revolving Facility Commitments in accordance with this Agreement) from time to time prior to such date.

“L/C Disbursement” shall mean a payment or disbursement made by Issuing Bank pursuant to a Letter of Credit.

“L/C Participation Fee” shall have the meaning assigned such term in Section 2.12(b).

“Lender” shall mean each financial institution listed on Schedule 2.01 (other than any such person that has ceased to be a party hereto pursuant to an Assignment and Acceptance in accordance with Section 9.04), as well as any person that becomes a “Lender” hereunder pursuant to Section 9.04 or Section 2.21. Unless the context clearly indicates otherwise, the term “Lenders” shall include the maker of Swingline Loans.

“Lending Office” shall mean, as to any Lender, the applicable branch, office or Affiliate of such Lender designated by such Lender to make Loans.

“Letter of Credit” shall have the meaning assigned to such term in Section 2.05(a).

“Letter of Credit Commitment” shall mean, with respect to each Issuing Bank, the commitment of such Issuing Bank to issue Letters of Credit pursuant to Section 2.05.

“Letter of Credit Sublimit” shall mean the aggregate Letter of Credit Commitments of the Issuing Banks, in an amount not to exceed \$10,000,000.

“LIBOR Rate” means for any Interest Period as to any Eurocurrency Loan, (i) the rate per annum determined by the Administrative Agent to be the offered rate which appears on the page of the Reuters Screen which displays the London interbank offered rate administered by ICE Benchmark Administration Limited (such page currently being the LIBOR01 page) (“LIBOR”) for deposits (for delivery on the first day of such Interest Period) with a term equivalent to such Interest Period in Dollars, determined as of approximately 11:00 a.m. (London, England time), two Business Days prior to the commencement of such Interest Period, or (ii) in the event the rate referenced in the preceding clause (i) does not appear on such page or service or if such page or service shall cease to be available, the rate determined by the Administrative Agent to be the offered rate on such other page or other service which displays LIBOR for deposits (for delivery on the first day of such Interest Period) with a term equivalent to such Interest Period in Dollars, determined as of approximately 11:00 a.m. (London, England time) two Business Days prior to the commencement of such Interest Period; provided that if LIBOR is quoted under either of the preceding clauses (i) or (ii), but there is no such quotation for the Interest Period elected, LIBOR shall be equal to the Interpolated Rate.

“Lien” shall mean, with respect to any asset, (a) any mortgage, deed of trust, lien, hypothecation, pledge, charge, security interest or similar monetary encumbrance in or on such asset and (b) the interest of a vendor or a lessor under any conditional sale agreement, capital lease or title retention agreement (or any financing lease having substantially the same economic effect as any of the foregoing) relating to such asset; provided, that in no event shall an operating lease or an agreement to sell be deemed to constitute a Lien.

“Loan Documents” shall mean (i) this Agreement, (ii) the Guarantee Agreement, (iii) the Security Documents, (iv) each Incremental Assumption Agreement, (v) any Permitted Intercreditor Agreement, (vi) the Letters of Credit, (vii) any Note issued under Section 2.09(e) and (viii) solely for purposes of Sections 4.02 and 7.01 hereof, the Fee Letter.

“Loan Obligations” shall mean (a) the due and punctual payment by the Borrower of (i) the unpaid principal of and interest (including interest accruing during the pendency of any bankruptcy, insolvency, receivership or other similar proceeding, regardless of whether allowed or allowable in such proceeding) on the Loans made to the Borrower under this Agreement, when and as due, whether at maturity, by acceleration, upon one or more dates set for prepayment or otherwise, (ii) each payment required to be made by the Borrower under this Agreement in respect of any Letter of Credit, when and as due, including payments in respect of reimbursement of disbursements, interest thereon (including interest accruing during the pendency of any bankruptcy, insolvency, receivership or other similar proceeding, regardless of whether allowed or allowable in such proceeding) and obligations to provide Cash Collateral and

(iii) all other monetary obligations of the Borrower owed under or pursuant to this Agreement and each other Loan Document, including obligations to pay fees, expense reimbursement obligations and indemnification obligations, whether primary, secondary, direct, contingent, fixed or otherwise (including monetary obligations incurred during the pendency of any bankruptcy, insolvency, receivership or other similar proceeding, regardless of whether allowed or allowable in such proceeding), and (b) the due and punctual payment of all obligations of each other Loan Party under or pursuant to each of the Loan Documents.

“Loan Parties” shall mean Holdings (prior to a Qualified IPO of the Borrower), the Borrower, and the Subsidiary Loan Parties.

“Loans” shall mean the Revolving Loans and the Swingline Loans.

“Local Time” shall mean New York City time (daylight or standard, as applicable).

“Location Reserve” shall mean a reserve established by the Administrative Agent in its Reasonable Credit Judgment (not to exceed the amount payable by any Loan Party for a period of 60 days to each person in possession or control of the premises where the relevant Equipment or Inventory is located as determined by the Administrative Agent in its Reasonable Credit Judgment).

“Management Group” shall mean the group consisting of the directors, executive officers and other management personnel of the Borrower, Holdings or any Parent Entity, as the case may be, on the Closing Date together with (a) any new directors whose election by such boards of directors or whose nomination for election by the shareholders of the Borrower, Holdings or any Parent Entity, as the case may be, was approved by a vote of a majority of the directors of the Borrower, Holdings or any Parent Entity, as the case may be, then still in office who were either directors on the Closing Date or whose election or nomination was previously so approved and (b) executive officers and other management personnel of the Borrower, Holdings or any Parent Entity, as the case may be, hired at a time when the directors on the Closing Date together with the directors so approved constituted a majority of the directors of the Borrower or Holdings, as the case may be.

“Margin Stock” shall have the meaning assigned to such term in Regulation U.

“Material Adverse Effect” shall mean a material adverse effect on the business, property, operations or financial condition of the Borrower and the Subsidiaries, taken as a whole, or the validity or enforceability of any of the Loan Documents or the rights and remedies of the Administrative Agent and the Lenders thereunder.

“Material Increase Acquisition” shall mean any acquisition of a business or other assets if the inclusion of the Eligible Accounts, Eligible Credit Card Accounts, Eligible Equipment and/or Eligible Inventory so acquired in the Borrowing Base on a Pro Forma Basis at the time of such acquisition would result in an increase in Availability by (i) more than \$4,000,000 in the aggregate for all assets acquired in such acquisition (whether such acquisition is carried out in a single transaction or in multiple substantially concurrent transactions with



seller parties that are Affiliates of each other) or (ii) more than \$8,000,000 in the aggregate for all assets acquired in such acquisition and any other acquisitions to the extent the assets acquired in such other acquisitions have not yet been subjected to collateral audits, appraisals or updates of appraisals, as applicable, pursuant to either the fourth paragraph of the definition of “Borrowing Base” or Section 5.07 (collectively, “Unaudited Acquired Assets”).

“Material Indebtedness” shall mean Indebtedness (other than Loans and Letters of Credit) of any one or more of the Borrower or any Subsidiary in an aggregate principal amount exceeding \$10,000,000.

“Material Real Property” shall mean any parcel or parcels of Real Property now or hereafter owned in fee by any Loan Party that have a fair market value (on a per-property basis) of at least \$5,000,000 as of (x) the Closing Date for Real Property now owned or (y) the date of acquisition for Real Property acquired after the Closing Date, in each case as determined by the Borrower in good faith.

“Material Subsidiary” shall mean any Subsidiary other than an Immaterial Subsidiary.

“Maturity Date” shall mean, as the context may require, (a) with respect to the Revolving Facility Commitments, the date that is three (3) years after the Closing Date, and (b) with respect to any other Class of Loans or Commitments, the maturity dates specified therefor in the applicable Incremental Assumption Agreement.

“Maximum Availability” shall mean, at any time, the lesser of (a) the total Revolving Commitments at such time and (b) the Borrowing Base at such time.

“Maximum Rate” shall have the meaning assigned to such term in Section 9.09.

“Metric Report” means, with respect to the financial statements for which such report is required, a report listing the following metrics for the periods covered by such financial statements: (i) revenue passenger mile, (ii) available seat mile, (iii) revenue per available seat mile, (iv) cost per available seat mile (CASM), (v) CASM ex-fuel, (vi) load factor, (vii) aircraft fleet size (owned and leased) and (viii) fuel gallons consumed.

“Minimum L/C Collateral Amount” shall mean, at any time, in connection with any Letter of Credit, (i) with respect to Cash Collateral consisting of cash or deposit account balances, an amount equal to 103% of the Revolving L/C Exposure with respect to such Letter of Credit at such time and (ii) otherwise, an amount sufficient to provide credit support with respect to such Revolving L/C Exposure as determined by the Administrative Agent and the Issuing Banks in their sole discretion.

“Model” shall mean the financial model provided to the Arranger prior to the date of this Agreement.

“Moody’s” shall mean Moody’s Investors Service, Inc.

“Mortgaged Properties” shall mean the Material Real Properties owned in fee by the Loan Parties that are set forth on Schedule 1.01(B) and each additional Material Real Property encumbered by a Mortgage pursuant to Section 5.10.

“Mortgages” shall mean, collectively, the mortgages, trust deeds, deeds of trust, deeds to secure debt, assignments of leases and rents, and other security documents (including amendments to any of the foregoing) delivered with respect to Mortgaged Properties, each in a form reasonably acceptable to the Borrower and the Collateral Agent, as amended, supplemented or otherwise modified from time to time.

“Multiemployer Plan” shall mean a multiemployer plan as defined in Section 4001(a)(3) of ERISA to which the Borrower, Holdings or any Subsidiary or any ERISA Affiliate (other than one considered an ERISA Affiliate only pursuant to subsection (m) or (o) of Code Section 414) is making or accruing an obligation to make contributions, or has within any of the preceding six plan years made or accrued an obligation to make contributions.

“Net Amount” shall mean, at any time, the gross amount with respect to any Eligible Accounts or Eligible Credit Card Accounts as applicable, less returns, discounts, claims, credits, and allowances of any nature at any time issued, owing, granted, outstanding, available, or claimed (in each case without duplication, whether of the exclusionary criteria set forth in the definition of Eligible Accounts or Eligible Credit Card Accounts or of any Reserve, or otherwise).

“Net Book Value” shall mean, with respect to any Equipment or Inventory, the cost of such Equipment or Inventory, as applicable, minus the accumulated depreciation of such Equipment or Inventory, as applicable, calculated in accordance with GAAP.

“Net Income” shall mean, with respect to any person, the net income (loss) of such person, determined in accordance with GAAP and before any reduction in respect of preferred stock dividends.

“New Project” shall mean (x) each facility which is either a new facility or an expansion of an existing facility owned by the Borrower or the Subsidiaries which in fact commences operations and (y) each creation (in one or a series of related transactions) of a business unit or product line to the extent such business unit or product line commences operations or production or each expansion (in one or a series of related transactions) of business into a new market or distribution or sales channel; provided, that there shall be no New Project within the first six months after the Closing Date other than in connection with a Permitted Business Acquisition or an acquisition of a Similar Business.

“Non-Consenting Lender” shall have the meaning assigned to such term in Section 2.19(c).

“Non-Defaulting Lender” shall mean, at any time, each Lender that is not a Defaulting Lender at such time.

“Note” shall have the meaning assigned to such term in Section 2.09(e).

“Obligations” shall mean, collectively, (a) the Loan Obligations, (b) obligations in respect of any Secured Cash Management Agreement and (c) obligations (other than Excluded Swap Obligations) in respect of any Secured Hedge Agreement.

“OFAC” shall mean the United States Department of the Treasury’s Office of Foreign Assets Control.

“Other Taxes” shall mean any and all present or future stamp or documentary Taxes or any other excise, transfer, sales, property, intangible, mortgage recording or similar Taxes arising from any payment made hereunder or under any other Loan Document or from the execution, registration, delivery or enforcement of, consummation or administration of, from the receipt of perfection of security interest under, or otherwise with respect to, the Loan Documents (but excluding any Excluded Taxes), except any such Taxes that are imposed with respect to an assignment (other than an assignment made pursuant to Section 2.19).

“Outside Date” shall mean the date that is 30 days after the End Date (as defined in the Purchase Agreement as in effect on the date hereof and as may be extended in accordance with the terms of the Purchase Agreement as in effect on the date hereof) or, if earlier, the date on which the Purchase Agreement is terminated without the consummation of the Acquisition.

“Overadvance” shall have the meaning assigned thereto in Section 2.01(b).

“Parent Entity” shall mean any direct or indirect parent of the Borrower.

“Pari Passu Secured Hedge Obligations” shall have the meaning assigned to such term in Section 8.13(a).

“Participant” shall have the meaning assigned to such term in Section 9.04(d)(i).

“Participant Register” shall have the meaning assigned to such term in Section 9.04(d)(ii).

“Payment Conditions” shall mean that (a) prior to and after giving effect to the relevant action as to which the satisfaction of the Payment Conditions is being determined, no Default or Event of Default shall have occurred or been continuing, (b) (A) daily average Availability for the period of 30 consecutive calendar days immediately preceding such action and Availability as of the date of such action, in each case, on a Pro Forma Basis after giving effect to such action and any Borrowings and Letter of Credit issuance incurred in connection therewith, shall be at least equal to \$10,000,000, or (B) (1) daily average Availability for the period of 30 consecutive calendars days immediately preceding such action and Availability as of the date of such action, in each case, on a Pro Forma Basis after giving effect to such action and any Borrowings and Letter of Credit issuance incurred in connection therewith, shall be at least equal to \$7,000,000 and (2) the Fixed Charge Coverage Ratio for the Test Period most recently ended, determined on a Pro Forma Basis after giving effect to such action, shall be no less than 1.00 to 1.00, and (c) the Borrower shall have delivered to the Administrative Agent an officer’s certificate executed by a Responsible Officer of the Borrower setting forth the calculations under, and certifying to the best of such officer’s knowledge, compliance with the requirements of, the preceding clause (b).

“PBGC” shall mean the Pension Benefit Guaranty Corporation referred to and defined in ERISA.

“Perfection Certificate” shall mean the Perfection Certificate with respect to the Borrower and the other Loan Parties in a form reasonably satisfactory to the Administrative Agent, as the same may be supplemented from time to time to the extent required by Section 5.04(f).

“Permitted Business Acquisition” shall mean any acquisition of all or substantially all the assets of, or all or substantially all the Equity Interests (other than directors’ qualifying shares) not previously held by the Borrower and the Subsidiaries in, or merger, consolidation or amalgamation with, a person or division or line of business of a person (or any subsequent investment made in a person, division or line of business previously acquired in a Permitted Business Acquisition), if immediately after giving effect thereto: (i) no Event of Default shall have occurred and be continuing or would result therefrom, provided, however, that with respect to a proposed acquisition pursuant to an executed acquisition agreement, at the option of the Borrower, the determination of whether such an Event of Default shall exist shall be made solely at the time of the execution of the acquisition agreement related to such Permitted Business Acquisition; (ii) all transactions related thereto shall be consummated in accordance with applicable laws; (iii) any acquired or newly formed Subsidiary shall not be liable for any Indebtedness except for Indebtedness permitted by Section 6.01; (iv) to the extent required by Section 5.10, any person acquired in such acquisition, if acquired by the Borrower or a Domestic Subsidiary, shall be merged into the Borrower or a Subsidiary Loan Party or become upon consummation of such acquisition a Subsidiary Loan Party; and (v) the aggregate cash consideration in respect of such acquisitions and investments in assets that are not owned by the Borrower or Subsidiary Loan Parties or in Equity Interests in persons that are not Subsidiary Loan Parties or do not become Subsidiary Loan Parties upon consummation of such acquisition shall not exceed the greater of (x) \$5,000,000 and (y) 0.046 times EBITDAR calculated on a Pro Forma Basis for the then most recently ended Test Period.

“Permitted Cure Securities” shall mean any equity securities of the Borrower other than Disqualified Stock.

“Permitted Holder Group” shall have the meaning assigned to such term in the definition of the term “Permitted Holders”.

“Permitted Holders” shall mean (i) the Co-Investors, (ii) any person that has no material assets other than the capital stock of the Borrower and that, directly or indirectly, holds or acquires beneficial ownership of 100% on a fully diluted basis of the voting Equity Interests of the Borrower, and of which no other person or “group” (within the meaning of Rules 13d-3 and 13d-5 under the Exchange Act as in effect on the Closing Date), other than any of the other Permitted Holders specified in clause (i), beneficially owns more than 50% (or, following a Qualified IPO, the greater of 35% and the percentage beneficially owned by the Permitted Holders specified in clause (i)) on a fully diluted basis of the voting Equity Interests thereof and

(iii) any “group” (within the meaning of Rules 13d-3 and 13d-5 under the Exchange Act as in effect on the Closing Date) the members of which include any of the other Permitted Holders specified in clause (i) and that, directly or indirectly, hold or acquire beneficial ownership of the voting Equity Interests of the Borrower (a “Permitted Holder Group”), so long as (1) each member of the Permitted Holder Group has voting rights proportional to the percentage of ownership interests held or acquired by such member and (2) no person or other “group” (other than the other Permitted Holders specified in clause (i)) beneficially owns more than 50% (or, following a Qualified IPO, the greater of 35% and the percentage beneficially owned by the Permitted Holders specified in clause (i)) on a fully diluted basis of the voting Equity Interests held by the Permitted Holder Group.

“Permitted Intercreditor Agreement” shall mean, with respect to any Liens on the Collateral that are intended to be junior to the Liens thereon securing the Loan Obligations, any intercreditor agreement the terms of which are consistent with market terms governing security arrangements for the sharing of current asset collateral on a junior basis at the time such intercreditor agreement is proposed to be established, as mutually determined by the Borrower in good faith and the Administrative Agent in the reasonable exercise of its judgment.

“Permitted Investments” shall mean:

(a) direct obligations of the United States of America or any member of the European Union or any agency thereof or obligations guaranteed by the United States of America or any member of the European Union or any agency thereof, in each case with maturities not exceeding two years;

(b) time deposit accounts, certificates of deposit and money market deposits maturing within 180 days of the date of acquisition thereof issued by a bank or trust company that is organized under the laws of the United States of America, any state thereof or any foreign country recognized by the United States of America having capital, surplus and undivided profits in excess of \$250,000,000 and whose long-term debt, or whose parent holding company’s long-term debt, is rated A (or such similar equivalent rating or higher by at least one nationally recognized statistical rating organization (as defined in Rule 436 under the Securities Act));

(c) repurchase obligations with a term of not more than 180 days for underlying securities of the types described in clause (a) above entered into with a bank meeting the qualifications described in clause (b) above;

(d) commercial paper, maturing not more than one year after the date of acquisition, issued by a corporation (other than an Affiliate of the Borrower) organized and in existence under the laws of the United States of America or any foreign country recognized by the United States of America with a rating at the time as of which any investment therein is made of P1 (or higher) according to Moody’s, or A1 (or higher) according to S&P (or such similar equivalent rating or higher by at least one nationally recognized statistical rating organization (as defined in Rule 436 under the Securities Act));

(e) securities with maturities of two years or less from the date of acquisition, issued or fully guaranteed by any State, commonwealth or territory of the United States of America, or by any political subdivision or taxing authority thereof, and rated at least A by S&P or A by Moody's (or such similar equivalent rating or higher by at least one nationally recognized statistical rating organization (as defined in Rule 436 under the Securities Act));

(f) shares of mutual funds whose investment guidelines restrict 95% of such funds' investments to those satisfying the provisions of clauses (a) through (e) above;

(g) money market funds that (i) comply with the criteria set forth in Rule 2a-7 under the Investment Company Act of 1940, (ii) are rated AAA by S&P and Aaa by Moody's and (iii) have portfolio assets of at least \$5,000,000,000;

(h) time deposit accounts, certificates of deposit and money market deposits in an aggregate face amount not in excess of 0.5% of the total assets of the Borrower and the Subsidiaries, on a consolidated basis, as of the end of the Borrower's most recently completed fiscal year; and

(i) instruments equivalent to those referred to in clauses (a) through (h) above denominated in any foreign currency comparable in credit quality and tenor to those referred to above and commonly used by corporations for cash management purposes in any jurisdiction outside the United States of America to the extent reasonably required in connection with any business conducted by any Subsidiary organized in such jurisdiction.

"Permitted Liens" shall have the meaning assigned to such term in Section 6.02.

"Permitted Refinancing Indebtedness" shall mean any Indebtedness issued in exchange for, or the net proceeds of which are used to extend, refinance, renew, replace, defease or refund (collectively, to "Refinance"), the Indebtedness being Refinanced (or previous refinancings thereof constituting Permitted Refinancing Indebtedness); provided, that (a) the principal amount (or accreted value, if applicable) of such Permitted Refinancing Indebtedness does not exceed the principal amount (or accreted value, if applicable) of the Indebtedness so Refinanced (plus unpaid accrued interest and premium (including tender premiums) thereon and underwriting discounts, defeasance costs, fees, commissions, expenses, plus an amount equal to any existing commitment unutilized thereunder and letters of credit undrawn thereunder), (b) except with respect to Section 6.01(i), (i) the final maturity date of such Permitted Refinancing Indebtedness is on or after the earlier of (x) the final maturity date of the Indebtedness being Refinanced and (y) the Latest Maturity Date in effect at the time of incurrence and (ii) the Weighted Average Life to Maturity of such Permitted Refinancing Indebtedness is greater than or equal to the lesser of (i) the Weighted Average Life to Maturity of the Indebtedness being Refinanced and (ii) the Weighted Average Life to Maturity of the Class of Revolving Loans then outstanding with the greatest remaining Weighted Average Life to Maturity, (c) if the Indebtedness being Refinanced is subordinated in right of payment to the Loan Obligations under this Agreement, such Permitted Refinancing Indebtedness shall be subordinated in right of payment to such Loan Obligations on terms in the aggregate not materially less favorable to the Lenders as those contained in the documentation governing the Indebtedness being Refinanced, (d) no Permitted Refinancing Indebtedness shall have obligors that are not (or would not have been) obligated with respect to the Indebtedness so Refinanced than the Indebtedness being Refinanced (except that a Loan Party may be added as an additional

obligor) and (e) if the Indebtedness being Refinanced is secured by Liens on any Collateral (whether senior to, equally and ratably with, or junior to the Liens on such Collateral securing the Loan Obligations under this Agreement or otherwise), such Permitted Refinancing Indebtedness may be secured by such Collateral (including any Collateral pursuant to after-acquired property clauses to the extent any such Collateral secured (or would have secured) the Indebtedness being Refinanced) so long as it complies with Section 6.02.

“Permitted Transferees” means, with respect to any person that is a natural person (and any Permitted Transferee of such person), (x) such person’s immediate family, including his or her spouse, ex-spouse, children, stepchildren and their respective lineal descendants and (y) any trust or other legal entity the beneficiary of which is such person’s immediate family, including his or her spouse, ex-spouse, children, stepchildren or their respective lineal descendants and which is controlled by such person.

“person” shall mean any natural person, corporation, business trust, joint venture, association, company, partnership, limited liability company or government, individual or family trusts, or any agency or political subdivision thereof.

“Plan” shall mean any employee pension benefit plan (other than a Multiemployer Plan) that is (i) subject to the provisions of Title IV of ERISA or Section 412 of the Code or Section 302 of ERISA, (ii) sponsored or maintained (at the time of determination or at any time within the five years prior thereto) by Holdings, the Borrower or any ERISA Affiliate, and (iii) in respect of which Holdings, the Borrower, any Subsidiary or any ERISA Affiliate is (or, if such plan were terminated, would under Section 4069 of ERISA be deemed to be) an “employer” as defined in Section 3(5) of ERISA.

“Platform” shall have the meaning assigned to such term in Section 9.17.

“Pledged Collateral” shall have the meaning assigned to such term in the Collateral Agreement. “primary obligor” shall have the meaning assigned to such term in the definition of the term “Guarantee”.

“Prime Rate” shall mean the rate of interest last quoted by The Wall Street Journal as the “Prime Rate” in the U.S. or, if The Wall Street Journal ceases to quote such rate, the highest per annum interest rate published by the Federal Reserve Board in Federal Reserve Statistical Release H.15 (519) (Selected Interest Rates) as the “bank prime loan” rate or, if such rate is no longer quoted therein, any similar rate quoted therein (as determined by the Administrative Agent) or any similar release by the Federal Reserve Board (as determined by the Administrative Agent).

“Pro Forma Basis” shall mean, as to any person, for any events as described below that occur subsequent to the commencement of a period for which the financial effect of such events is being calculated, and giving effect to the events for which such calculation is being made, such calculation as will give pro forma effect to such events as if such events occurred on the first day of the four consecutive fiscal quarter period ended on or before the occurrence of such event (the “Reference Period”): (i) pro forma effect shall be given to any Disposition, any acquisition, Investment, capital expenditure, construction, repair, replacement,

improvement, development, disposition, merger, amalgamation, consolidation (including the Transactions) (or any similar transaction or transactions not otherwise permitted under Section 6.04 or 6.05 that require a waiver or consent of the Required Lenders and such waiver or consent has been obtained), any dividend, distribution or other similar payment, any designation of any Subsidiary as an Unrestricted Subsidiary and any Subsidiary Redesignation, New Project, and any restructurings of the business of the Borrower or any of the Subsidiaries that the Borrower or any of the Subsidiaries has determined to make and/or made and in the good faith determination of a Responsible Officer of the Borrower are expected to have a continuing impact and are factually supportable, which would include cost savings resulting from head count reduction, closure of facilities and similar operational and other cost savings, which adjustments the Borrower determines are reasonable as set forth in a certificate of a Financial Officer of the Borrower (the foregoing, together with any transactions related thereto or in connection therewith, the “relevant transactions”), in each case that occurred during the Reference Period (or, in the case of determinations made pursuant to Article II or Article VI, occurring during the Reference Period or thereafter and through and including the date upon which the relevant transaction is consummated), (ii) in making any determination on a Pro Forma Basis, (x) all Indebtedness (including Indebtedness issued, incurred or assumed as a result of, or to finance, any relevant transactions and for which the financial effect is being calculated, whether incurred under this Agreement or otherwise, but excluding normal fluctuations in revolving Indebtedness incurred for working capital purposes, in each case not to finance any acquisition) issued, incurred, assumed or permanently repaid during the Reference Period (or, in the case of determinations made pursuant to Article II or Article VI, occurring during the Reference Period or thereafter and through and including the date upon which the relevant transaction is consummated) shall be deemed to have been issued, incurred, assumed or permanently repaid at the beginning of such period, (y) Interest Expense of such person attributable to interest on any Indebtedness, for which pro forma effect is being given as provided in the preceding clause (x), bearing floating interest rates shall be computed on a pro forma basis as if the rates that would have been in effect during the period for which pro forma effect is being given had been actually in effect during such periods, and (z) in giving effect to clause (i) above with respect to each New Project which commences operations and records not less than one full fiscal quarter’s operations during the Reference Period, the operating results of such New Project shall be annualized on a straight line basis during such period, taking into account any seasonality adjustments determined by the Borrower in good faith, and (iii) (A) any Subsidiary Redesignation then being designated, effect shall be given to such Subsidiary Redesignation and all other Subsidiary Redesignations after the first day of the relevant Reference Period and on or prior to the date of the respective Subsidiary Redesignation then being designated, collectively, and (B) any designation of a Subsidiary as an Unrestricted Subsidiary, effect shall be given to such designation and all other designations of Subsidiaries as Unrestricted Subsidiaries after the first day of the relevant Reference Period and on or prior to the date of the then applicable designation of a Subsidiary as an Unrestricted Subsidiary, collectively.

Pro forma calculations made pursuant to the definition of the term “Pro Forma Basis” shall be determined in good faith by a Responsible Officer of the Borrower and may include adjustments to reflect (1) operating expense reductions and other operating improvements, synergies or cost savings reasonably expected to result from any relevant pro forma event (including, to the extent applicable, the Transactions), and (2) all adjustments of the type used in connection with the calculation of “Adjusted EBITDAR” as set forth in the Model to the extent such adjustments, without duplication, continue to be applicable to such Reference Period.



For purposes of this definition, any amount in a currency other than Dollars will be converted to Dollars based on the average exchange rate for such currency for the most recent twelve-month period immediately prior to the date of determination in a manner consistent with that used in calculating EBITDAR for the applicable period.

“Pro Rata Extension Offers” shall have the meaning assigned to such term in Section 2.21(e).

“Projections” shall mean the projections of the Borrower and the Subsidiaries included in the Model and any other projections and any forward-looking statements (including statements with respect to booked business) of such entities furnished to the Lenders or the Administrative Agent by or on behalf of the Borrower or any of the Subsidiaries prior to the Closing Date.

“Protective Advances” shall have the meaning assigned to such term in Section 2.01(c).

“PTE” means a prohibited transaction class exemption issued by the U.S. Department of Labor, as any such exemption may be amended from time to time.

“Public Company Compliance” shall mean compliance with the requirements of the Sarbanes-Oxley Act of 2002 and the rules and regulations promulgated in connection therewith, the provisions of the Securities Act and the Exchange Act, and the rules of national securities exchange listed companies (in each case, as applicable to companies with equity or debt securities held by the public), including procuring directors’ and officers’ insurance, legal and other professional fees, and listing fees.

“Public Lender” shall have the meaning assigned to such term in Section 9.17.

“Purchase Agreement” shall have the meaning assigned to such term in the first recital hereto.

“Qualified Equity Interests” shall mean any Equity Interest other than Disqualified Stock.

“Qualified IPO” shall mean an underwritten public offering of the Equity Interests of the Borrower, Holdings, any Parent Entity, which generates cash proceeds of at least \$75,000,000.

“Rate” shall have the meaning assigned to such term in the definition of the term “Type”.

“Real Property” shall mean, collectively, all right, title and interest (including any leasehold estate) in and to any and all parcels of or interests in real property owned in fee or leased by any Loan Party, whether by lease, license, or other means, together with, in each case, all easements, hereditaments and appurtenances relating thereto, all improvements and appurtenant fixtures and equipment, incidental to the ownership, lease or operation thereof.

“Reasonable Credit Judgment” shall mean the Administrative Agent’s commercially reasonable credit judgment exercised in good faith in accordance with customary business practices for comparable asset-based lending transactions and, as it relates to the establishment or increase of Reserves or the adjustment or imposition of exclusionary criteria, shall require that, (x) such establishment, increase, adjustment or imposition after the Closing Date be based on the analysis of facts or events first occurring or first discovered by the Administrative Agent after the Closing Date or that are materially different from facts or events occurring or known to the Administrative Agent on the Closing Date, (y) the contributing factors to the imposition or increase of any Reserve shall not duplicate the exclusionary criteria set forth in the definitions of “Eligible Accounts”, “Eligible Credit Card Accounts”, “Eligible Equipment” and “Eligible Inventory”, as applicable (and vice versa) and (z) the amount of any such Reserve so established or the effect of any adjustment or imposition of exclusionary criteria shall be a reasonable quantification of the incremental dilution of the Borrowing Base attributable to such contributing factors.

“Reference Period” shall have the meaning assigned to such term in the definition of the term “Pro Forma Basis”.

“Refinance” shall have the meaning assigned to such term in the definition of the term “Permitted Refinancing Indebtedness”, and “Refinanced” shall have a meaning correlative thereto.

“Register” shall have the meaning assigned to such term in Section 9.04(b)(iv).

“Regulation T” shall mean Regulation T of the Board as from time to time in effect and all official rulings and interpretations thereunder or thereof.

“Regulation U” shall mean Regulation U of the Board as from time to time in effect and all official rulings and interpretations thereunder or thereof.

“Regulation X” shall mean Regulation X of the Board as from time to time in effect and all official rulings and interpretations thereunder or thereof.

“Related Fund” shall mean, with respect to any Lender that is a fund that invests in bank or commercial loans and similar extensions of credit, any other fund that invests in bank or commercial loans and similar extensions of credit and is advised or managed by (a) such Lender, (b) an Affiliate of such Lender or (c) an entity (or an Affiliate of such entity) that administers, advises or manages such Lender.

“Related Parties” shall mean, with respect to any specified person, such person’s Affiliates and the respective directors, trustees, officers, employees, agents and advisors of such person and such person’s Affiliates.

“Related Sections” shall have the meaning assigned to such term in Section 6.04.

“Release” shall mean any spilling, leaking, seepage, pumping, pouring, emitting, emptying, discharging, injecting, escaping, leaching, dumping, disposing, depositing, emanating or migrating in, into, onto or through the Environment.

“Reportable Event” shall mean any reportable event as defined in Section 4043(c) of ERISA or the regulations issued thereunder, other than those events as to which the 30-day notice period referred to in Section 4043(c) of ERISA has been waived, with respect to a Plan (other than a Plan maintained by an ERISA Affiliate that is considered an ERISA Affiliate only pursuant to subsection (m) or (o) of Section 414 of the Code).

“Reporting Triggering Event” shall occur at any time that (a) Availability is less than \$5,000,000 for five (5) consecutive Business Days or (b) an Event of Default shall have occurred and be continuing. Once occurred, a Reporting Triggering Event described in clause (a) shall be deemed to be continuing until such time as Availability is at least equal to \$5,000,000 for twenty (20) consecutive Business Days, and a Reporting Triggering Event described in clause (b) shall be deemed to be continuing until no Event of Default shall be continuing.

“Required Lenders” shall mean, at any time, Lenders having (a) Revolving Facility Credit Exposure and (b) Available Unused Commitments, that taken together, represent more than 50% of the sum of (x) all Revolving Facility Credit Exposure and (y) the total Available Unused Commitment; provided, that the Loans of any Defaulting Lender shall be disregarded in determining Required Lenders at any time.

“Requirement of Law” shall mean, as to any person, any law, treaty, rule, regulation, statute, order, ordinance, decree, judgment, consent decree, writ, injunction, settlement agreement or governmental requirement enacted, promulgated or imposed or entered into or agreed by any Governmental Authority, in each case applicable to or binding upon such person or any of its property or assets or to which such person or any of its property or assets is subject.

“Reserves” shall mean (i) Location Reserves and (ii) such reserves against the Borrowing Base that the Administrative Agent has, in the exercise of its Reasonable Credit Judgment, established or increased from time to time upon at least five Business Days’ notice to the Borrower, including pursuant to Section 8.13.

“Responsible Officer” of any person shall mean any executive officer or Financial Officer of such person and any other officer or similar official thereof responsible for the administration of the obligations of such person in respect of this Agreement.

“Restricted Payments” shall have the meaning assigned to such term in Section 6.06. The amount of any Restricted Payment made other than in the form of cash or cash equivalents shall be the fair market value thereof (as determined by the Borrower in good faith).

“Revolving Commitment” shall mean, with respect to each Lender, the commitment of such Lender to make Revolving Loans pursuant to Section 2.01, expressed as an amount representing the maximum aggregate principal amount of such Lender’s Revolving Facility Credit Exposure hereunder, as such commitment may be (a) reduced from time to time pursuant to Section 2.08, (b) reduced or increased from time to time pursuant to assignments by or to such Lender under Section 9.04, and (c) increased as provided under Section 2.21. The initial amount of each Lender’s Revolving Commitment is set forth on Schedule 2.01, or in the Assignment and Acceptance or Incremental Assumption Agreement pursuant to which such Lender shall have assumed its Revolving Facility Commitment (or Extended Revolving Commitment), as applicable. The initial aggregate amount of the Lenders’ Revolving Facility Commitments (prior to any Incremental Revolving Commitments) is \$20,000,000.

“Revolving Facility Commitment” shall mean, with respect to each Lender, such Lender’s commitment to make Revolving Facility Loans.

“Revolving Facility Credit Exposure” shall mean, at any time, the sum of (a) the aggregate principal amount of the Revolving Facility Loans outstanding at such time, (b) the Swingline Exposure at such time and (c) the Revolving L/C Exposure at such time. The Revolving Facility Credit Exposure of any Revolving Lender at any time shall be the product of (x) such Revolving Lender’s Revolving Facility Percentage and (y) the aggregate Revolving Facility Credit Exposure of all Revolving Lenders, collectively, at such time.

“Revolving Facility Loan” shall mean the Initial Revolving Facility Loans and the Incremental Revolving Facility Loans or any of the foregoing.

“Revolving Facility Percentage” shall mean, with respect to any Lender, the percentage of the total Revolving Commitments of all Lenders represented by such Lender’s Revolving Commitment. If the Revolving Commitments have terminated or expired, the Revolving Facility Percentages shall be determined based upon the Revolving Commitments most recently in effect, giving effect to any assignments pursuant to Section 9.04.

“Revolving L/C Exposure” shall mean at any time the sum of (a) the aggregate undrawn amount of all Letters of Credit outstanding at such time and (b) the aggregate principal amount of all L/C Disbursements that have not yet been reimbursed at such time. The Revolving L/C Exposure of any Lender at any time shall mean its Revolving Facility Percentage of the aggregate Revolving L/C Exposure at such time. For all purposes of this Agreement, if on any date of determination a Letter of Credit has expired by its terms but any amount may still be drawn thereunder by reason of the operation of Rule 3.14 of the International Standard Practices, International Chamber of Commerce No. 590, such Letter of Credit shall be deemed to be “outstanding” in the amount so remaining available to be drawn. Unless otherwise specified herein, the amount of a Letter of Credit at any time shall be deemed to be the stated amount of such Letter of Credit in effect at such time; provided, that with respect to any Letter of Credit that, by its terms or the terms of any document related thereto, provides for one or more automatic increases in the stated amount thereof, the amount of such Letter of Credit shall be deemed to be the maximum stated amount of such Letter of Credit after giving effect to all such increases, whether or not such maximum stated amount is in effect at such time.

“Revolving Lender” shall mean a Lender other than a Swingline Lender.

“Revolving Loan” shall mean a Loan made pursuant to Section 2.01. Unless the context otherwise requires, the term “Revolving Loans” shall include the Extended Revolving Loans.

“S&P” shall mean Standard & Poor’s Ratings Group, Inc.

“Sale and Lease-Back Transaction” shall have the meaning assigned to such term in Section 6.03.

“Sanctions” shall have the meaning assigned to such term in Section 3.25(b).

“SEC” shall mean the Securities and Exchange Commission or any successor thereto.

“Secured Cash Management Agreement” shall mean any Cash Management Agreement that is entered into by and between any Loan Party and any Cash Management Bank to the extent that such Cash Management Agreement is designated in writing by the Borrower and such Cash Management Bank to the Administrative Agent as a Secured Cash Management Agreement.

“Secured Hedge Agreement” shall mean any Hedging Agreement that is entered into by and between any Loan Party and any Hedge Bank to the extent that such Hedging Agreement is designated in writing by the Borrower and such Hedge Bank to the Administrative Agent as a Secured Hedge Agreement in accordance with Section 8.13.

“Secured Hedge Counterparty” shall have the meaning assigned to such term in Section 8.13.

“Secured Parties” shall mean, collectively, the Administrative Agent, the Collateral Agent, each Lender, each Swingline Lender, each Issuing Bank, each Hedge Bank that is party to any Secured Hedge Agreement, each Cash Management Bank that is party to any Secured Cash Management Agreement and each sub-agent appointed pursuant to Section 8.02 by the Administrative Agent with respect to matters relating to the Loan Documents or by the Collateral Agent with respect to matters relating to any Security Document.

“Securities Act” shall mean the Securities Act of 1933, as amended.

“Security Documents” shall mean the Mortgages (if any), the Collateral Agreement, the IP Security Agreements (as defined in the Collateral Agreement), the Holdings Guarantee and Pledge Agreement and each of the security agreements, pledge agreements, and other instruments and documents executed and delivered pursuant to any of the foregoing or pursuant to Section 5.10.

“Seller” shall have the meaning assigned to such term in the first recital hereto.

“Settlement” shall have the meaning assigned to such term in Section 2.04(d)(i).

“Settlement Date” shall have the meaning assigned to such term in Section 2.04(d)(i).

“Similar Business” shall mean any business, the majority of whose revenues are derived from (i) business or activities conducted by the Borrower and the Subsidiaries on the Closing Date, (ii) any business that is a natural outgrowth or reasonable extension, development or expansion of any such business or any business similar, reasonably related, incidental, complementary or ancillary to any of the foregoing or (iii) any business that in the Borrower’s good faith business judgment constitutes a reasonable diversification of businesses conducted by the Borrower and the Subsidiaries.

“Spare Parts” shall mean any and all appliances, parts, instruments, appurtenances, accessories, avionics, furnishings, seats and other equipment of whatever nature which are of the type of aircraft spare parts, excluding any such spare parts to the extent installed on any aircraft or engine from time to time.

“Special Flood Hazard Area” shall have the meaning assigned to such term in Section 5.02(c).

“Spot Rate” shall mean, with respect to any currency, the rate determined by the Administrative Agent to be the rate quoted by the person acting in such capacity as the spot rate for the purchase by such person of such currency with another currency through its principal foreign exchange trading office at approximately 11:00 a.m., Local Time, on the date two Business Days prior to the date as of which the foreign exchange computation is made or if such rate cannot be computed as of such date such other date as the Administrative Agent shall reasonably determine is appropriate under the circumstances; provided, that the Administrative Agent may obtain such spot rate from another financial institution designated by the Administrative Agent if the person acting in such capacity does not have as of the date of determination a spot buying rate for any such currency.

“Startup Date” shall mean the date that is ninety (90) days after the Closing Date or such later date as the Administrative Agent may agree in its reasonable discretion.

“Statutory Reserves” shall mean the aggregate of the maximum reserve percentages (including any marginal, special, emergency or supplemental reserves) expressed as a decimal established by the Board and any other banking authority, domestic or foreign, to which the Administrative Agent or any Lender (including any branch, Affiliate or other fronting office making or holding a Loan) is subject for Eurocurrency Liabilities (as defined in Regulation D of the Board). Eurodollar Loans shall be deemed to constitute Eurocurrency Liabilities (as defined in Regulation D of the Board) and to be subject to such reserve requirements without benefit of or credit for proration, exemptions or offsets that may be available from time to time to any Lender under such Regulation D. Statutory Reserves shall be adjusted automatically on and as of the effective date of any change in any reserve percentage.

“Subagent” shall have the meaning assigned to such term in Section 8.02.

“subsidiary” shall mean, with respect to any person (herein referred to as the “parent”), any corporation, partnership, association or other business entity (a) of which securities or other ownership interests representing more than 50% of the equity or more than 50% of the ordinary voting power or more than 50% of the general partnership interests are, at the time any determination is being made, directly or indirectly, owned, Controlled or held, or (b) that is, at the time any determination is made, otherwise Controlled, by the parent or one or more subsidiaries of the parent or by the parent and one or more subsidiaries of the parent.

“Subsidiary” shall mean, unless the context otherwise requires, a subsidiary of the Borrower. Notwithstanding the foregoing (and except for purposes of the definition of “Unrestricted Subsidiary” contained herein), an Unrestricted Subsidiary shall be deemed not to be a Subsidiary of the Borrower or any of its Subsidiaries for purposes of this Agreement.

“Subsidiary Loan Party” shall mean (a) each Wholly Owned Domestic Subsidiary that is not an Excluded Subsidiary and (b) any other Subsidiary that may be designated by the Borrower (by way of delivering to the Collateral Agent a supplement to the Collateral Agreement and a supplement to the Guarantee Agreement, in each case, duly executed by such Subsidiary) in its sole discretion from time to time to be a guarantor in respect of the Obligations, whereupon such Subsidiary shall be obligated to comply with the other requirements of Section 5.10(d) as if it were newly acquired.

“Subsidiary Redesignation” shall have the meaning provided in the definition of “Unrestricted Subsidiary” contained in this Section 1.01.

“Super Majority Lenders” shall mean, at any time, Lenders having (a) Revolving Facility Credit Exposure and (b) Available Unused Commitments, that taken together, represent more than 66 $\frac{2}{3}$ % of the sum of (x) all Revolving Facility Credit Exposure and (y) the total Available Unused Commitments at such time. The Revolving Facility Credit Exposure and Available Unused Commitment of any Defaulting Lender shall be disregarded in determining the Super Majority Lenders at any time.

“Swap Obligation” shall mean, with respect to any Guarantor, any obligation to pay or perform under any agreement, contract or transaction that constitutes a “swap” within the meaning of Section 1a(47) of the Commodity Exchange Act.

“Swingline Borrowing” shall mean a Borrowing comprised of Swingline Loans.

“Swingline Borrowing Request” shall mean a request by the Borrowing substantially in the form of Exhibit D-2.

“Swingline Commitment” shall mean, with respect to each Swingline Lender, the commitment of such Swingline Lender to make Swingline Loans pursuant to Section 2.04. The aggregate amount of the Swingline Commitments \$10,000,000.

“Swingline Exposure” shall mean at any time the aggregate principal amount of all outstanding Swingline Borrowings at such time. The Swingline Exposure of any Lender at any time shall mean its Revolving Facility Percentage of the aggregate Swingline Exposure at such time.

“Swingline Lender” shall mean Barclays Bank PLC in its capacity as a lender of Swingline Loans.

“Swingline Loans” shall mean the swingline loans made to the Borrower pursuant to Section 2.04.

“Syndication Agent” shall mean Barclays Bank PLC.

“Taxes” shall mean any and all present or future taxes, duties, levies, imposts, assessments, deductions, withholdings or other similar charges imposed by any Governmental Authority, whether computed on a separate, consolidated, unitary, combined or other basis, and any interest, fines, penalties or additions to tax with respect to the foregoing.

“Termination Date” shall mean the date on which (a) the Commitments shall have been terminated, (b) the principal of and interest on each Loan, all Fees and all other expenses or amounts payable under any Loan Document shall have been paid in full (other than in respect of contingent indemnification and expense reimbursement claims not then due) and (c) all Letters of Credit (other than those that have been Cash Collateralized in accordance with Section 2.05(j) or (k)) have been cancelled or have expired and all amounts drawn or paid thereunder have been reimbursed in full.

“Testing Condition” shall be satisfied at any time if as of such time (i) the sum of without duplication (x) the aggregate principal amount of outstanding Revolving Facility Loans and Swingline Loans at such time and (y) the aggregate stated amount of Letters of Credit issued hereunder at such time (other than up to \$3,000,000 of undrawn Letters of Credit and any Letters of Credit that have been Cash Collateralized in accordance with Section 2.05(j)) exceeds (ii) an amount equal to 30% of the aggregate amount of the Revolving Facility Commitments at such time.

“Test Period” shall mean, on any date of determination, the period of four consecutive fiscal quarters of the Borrower then most recently ended (taken as one accounting period) for which financial statements have been (or were required to be) delivered pursuant to Section 5.04(a) or 5.04(b) and, initially, the four fiscal quarter period ending on the last day of the first full fiscal quarter ending after the Closing Date .

“Third Party Funds” shall mean any accounts or funds, or any portion thereof, received by Borrower or any of its Subsidiaries as agent on behalf of third parties (other than any Loan Parties) in accordance with a written agreement that imposes a duty upon Borrower or one or more of its Subsidiaries to collect and remit those funds to such third parties.

“Titled Equipment” shall mean any and all Equipment represented by a certificate of title issued under the laws of a State in the United States of America.



“Transaction Documents” shall mean the Purchase Agreement and the Loan Documents.

“Transaction Expenses” shall mean any fees or expenses incurred or paid by the Borrower or any of the Subsidiaries or any of their Affiliates in connection with the Transactions, this Agreement and the other Loan Documents, the Purchase Agreement, and the transactions contemplated hereby and thereby.

“Transactions” shall mean, collectively, the transactions to occur pursuant to the Transaction Documents, including (a) the consummation of the Acquisition; (b) the execution, delivery and performance of the Loan Documents, the creation of the Liens pursuant to the Security Documents, and the initial borrowings hereunder; (c) the Equity Financing; and (d) the funding of cash to the consolidated balance sheet of the Borrower and the Subsidiaries.

“Type” shall mean, when used in respect of any Loan or Borrowing, the Rate by reference to which interest on such Loan or on the Loans comprising such Borrowing is determined. For purposes hereof, the term “Rate” shall include the Adjusted LIBOR Rate and the ABR.

“Unaudited Acquired Assets” shall have the meaning assigned to such term in the definition of “Material Increase Acquisition”.

“Uniform Commercial Code” shall mean the Uniform Commercial Code as the same may from time to time be in effect in the State of New York or the Uniform Commercial Code (or similar code or statute) of another jurisdiction, to the extent it may be required to apply to any item or items of Collateral.

“Unrestricted Cash” shall mean cash or cash equivalents of the Borrower or any of the Subsidiaries that would not appear as “restricted” on a consolidated balance sheet of the Borrower or any of the Subsidiaries.

“Unrestricted Subsidiary” shall mean (1) any Subsidiary identified on Schedule 1.01(E), (2) any other Subsidiary, whether now owned or acquired or created after the Closing Date, that is designated by the Borrower as an Unrestricted Subsidiary hereunder by written notice to the Administrative Agent; provided, that the Borrower shall only be permitted to so designate a new Unrestricted Subsidiary after the Closing Date so long as (a) no Default or Event of Default has occurred and is continuing or would result therefrom, (b) such Unrestricted Subsidiary shall be capitalized (to the extent capitalized by the Borrower or any of its Subsidiaries) through Investments as permitted by, and in compliance with, Section 6.04, and any prior or concurrent Investments in such Subsidiary by the Borrower or any of its Subsidiaries shall be deemed to have been made under Section 6.04, and (c) without duplication of clause (b), any assets owned by such Unrestricted Subsidiary at the time of the initial designation thereof shall be treated as Investments pursuant to Section 6.04; provided, further, that at the time of the initial Investment by the Borrower or any of its Subsidiaries in such Subsidiary, the Borrower shall designate such entity as an Unrestricted Subsidiary in a written notice to the Administrative Agent, and (3) any subsidiary of an Unrestricted Subsidiary. The Borrower may designate any Unrestricted Subsidiary to be a Subsidiary for purposes of this Agreement (each, a “Subsidiary”).

Redesignation"); provided, that (i) no Default or Event of Default has occurred and is continuing or would result therefrom, and (ii) the Borrower shall have delivered to the Administrative Agent an officer's certificate executed by a Responsible Officer of the Borrower certifying to the best of such officer's knowledge, compliance with the requirements of preceding clause (i).

"U.S. Bankruptcy Code" shall mean Title 11 of the United States Code, as amended, or any similar federal or state law for the relief of debtors.

"U.S. Dollars", "Dollars" or "\$" shall mean lawful money of the United States of America.

"U.S. Lender" shall mean any Lender other than a Foreign Lender.

"USA PATRIOT Act" shall mean the Uniting and Strengthening America by Providing Appropriate Tools Required to Intercept and Obstruct Terrorism Act of 2001 (Title III of Pub. L. No. 107 56 (signed into law October 26, 2001)).

"Voting Stock" shall mean, with respect to any person, such person's Equity Interests having the right to vote for the election of directors of such person under ordinary circumstances.

"Weighted Average Life to Maturity" shall mean, when applied to any Indebtedness at any date, the number of years obtained by dividing: (a) the sum of the products obtained by multiplying (i) the amount of each then remaining installment, sinking fund, serial maturity or other required payments of principal, including payment at final maturity, in respect thereof, by (ii) the number of years (calculated to the nearest one-twelfth) that will elapse between such date and the making of such payment; by (b) the then outstanding principal amount of such Indebtedness.

"Wholly Owned Domestic Subsidiary" shall mean a Wholly Owned Subsidiary that is also a Domestic Subsidiary.

"Wholly Owned Subsidiary" of any person shall mean a subsidiary of such person, all of the Equity Interests of which (other than directors' qualifying shares or nominee or other similar shares required pursuant to applicable law) are owned by such person or another Wholly Owned Subsidiary of such person. Unless the context otherwise requires, "Wholly Owned Subsidiary" shall mean a Subsidiary of the Borrower that is a Wholly Owned Subsidiary of the Borrower.

"Withdrawal Liability" shall mean liability to a Multiemployer Plan as a result of a complete or partial withdrawal from such Multiemployer Plan, as such terms are defined in Part I of Subtitle E of Title IV of ERISA.

"Write-Down and Conversion Powers" shall mean, with respect to any EEA Resolution Authority, the write-down and conversion powers of such EEA Resolution Authority from time to time under the Bail-In Legislation for the applicable EEA Member Country, which write-down and conversion powers are described in the EU Bail-In Legislation Schedule.

Section 1.02 Terms Generally. The definitions set forth or referred to in Section 1.01 shall apply equally to both the singular and plural forms of the terms defined. Whenever the context may require, any pronoun shall include the corresponding masculine, feminine and neuter forms. The words “include,” “includes” and “including” shall be deemed to be followed by the phrase “without limitation.” All references herein to Articles, Sections, Exhibits and Schedules shall be deemed references to Articles and Sections of, and Exhibits and Schedules to, this Agreement unless the context shall otherwise require; provided that (i) the Schedules to this Agreement (other than Schedules 1.01(G), 1.01(H), 2.01 and 5.10) shall be updated on the Closing Date by the Borrower as reasonably agreed by the Borrower and the Administrative Agent, (ii) Schedules 1.01(G) and 1.01(H) shall not be attached hereto by the Borrower until the Closing Date and (iii) Schedule 5.10 shall be mutually agreed by the Borrower and the Administrative Agent to the extent needed on the Closing Date. Except as otherwise expressly provided herein, any reference in this Agreement to any Loan Document shall mean such document as amended, restated, supplemented or otherwise modified from time to time. Except as otherwise expressly provided herein, all terms of an accounting or financial nature shall be construed in accordance with GAAP, as in effect from time to time; provided, that, if the Borrower notifies the Administrative Agent that the Borrower requests an amendment to any provision hereof to eliminate the effect of any change occurring after the Closing Date in GAAP or in the application thereof on the operation of such provision (or if the Administrative Agent notifies the Borrower that the Required Lenders request an amendment to any provision hereof for such purpose), regardless of whether any such notice is given before or after such change in GAAP or in the application thereof, then such provision shall be interpreted on the basis of GAAP as in effect and applied immediately before such change shall have become effective until such notice shall have been withdrawn or such provision amended in accordance herewith. Notwithstanding any changes in GAAP after the Closing Date, any lease of the Borrower or the Subsidiaries that would be characterized as an operating lease under GAAP in effect on the Closing Date (whether such lease is entered into before or after the Closing Date) shall not constitute Indebtedness or a Capitalized Lease Obligation under this Agreement or any other Loan Document as a result of such changes in GAAP.

Section 1.03 Exchange Rates; Currency Equivalents. Except for purposes of financial statements delivered by Loan Parties hereunder or calculating financial ratios hereunder or except as otherwise provided herein, the applicable amount of any currency (other than Dollars) for purposes of the Loan Documents shall be such Dollar Equivalent amount as determined by the Administrative Agent in accordance with this Agreement. No Default or Event of Default shall arise as a result of any limitation or threshold set forth in Dollars in Article VI or clause (f) or (j) of Section 7.01 being exceeded solely as a result of changes in currency exchange rates from those rates applicable on the first day of the fiscal quarter in which such determination occurs or in respect of which such determination is being made.

Section 1.04 Timing of Payment or Performance. Except as otherwise expressly provided herein, when the payment of any obligation or the performance of any covenant, duty or obligation is stated to be due or performance required on a day which is not a Business Day, the date of such payment or performance shall extend to the immediately succeeding Business Day.

Section 1.05 Times of Day. Unless otherwise specified herein, all references herein to times of day shall be references to New York City time (daylight or standard, as applicable).

## ARTICLE II

### *The Credits*

Section 2.01 Commitments. Subject to the terms and conditions set forth herein:

(a) Revolving Loans. Each Lender agrees to make Revolving Loans in Dollars to the Borrower from time to time during the Availability Period, in an aggregate principal amount that will not result in (i) such Lender's Revolving Facility Credit Exposure exceeding the lesser of (x) such Lender's Revolving Commitment and (y) such Lender's Revolving Facility Percentage of the Borrowing Base or (ii) the aggregate Revolving Facility Credit Exposure of all Revolving Lenders exceeding Maximum Availability. Within the foregoing limits and subject to the terms and conditions set forth herein, the Borrower may borrow, prepay and reborrow Revolving Loans.

(b) Overadvances. Insofar as the Borrower may request and the Administrative Agent or Required Lenders may be willing in their sole and absolute discretion to make Revolving Loans to the Borrower at a time when the Revolving Facility Credit Exposure exceeds, or would exceed with the making of any such Revolving Loan, the Borrowing Base (any such Loan or Loans being herein referred to individually as an "Overadvance"), the Administrative Agent shall make such Overadvances available to the Borrower. All Overadvances shall be repaid on demand, shall be secured by the Collateral in accordance with the terms hereof and of the Security Documents and shall bear interest as provided in this Agreement for the Revolving Loans generally. The Required Lenders may at any time revoke the Administrative Agent's authorization to make future Overadvances (provided, that existing Overadvances shall not be subject to such revocation and any such revocation must be in writing and shall become effective prospectively upon the Administrative Agent's and the Borrower's receipt thereof). All Overadvances shall be ABR Loans. Any Overadvance made pursuant to the terms hereof shall be made by the Lenders ratably in accordance with their Revolving Facility Percentages. The foregoing notwithstanding, in no event (w) unless otherwise consented to by the Required Lenders, shall Overadvances, together with the Protective Advances then outstanding, in the aggregate exceed 10.0% of the then applicable Borrowing Base, (x) shall any Overadvances be outstanding for more than 45 consecutive days, (y) unless otherwise consented to by the Required Lenders, after all outstanding Overadvances have been repaid, shall the Administrative Agent make any additional Overadvances unless 10 days or more have expired since the last date on which any Overadvances were outstanding or (z) unless otherwise consented to by each affected Lender, shall the Administrative Agent make Revolving Loans on behalf of the applicable Lenders under this Section 2.01(b) to the extent such Revolving Loans would cause a Lender's share of the Revolving Facility Credit Exposure to exceed such Lender's Revolving Commitment or the aggregate principal amount of Revolving Loans exceed the aggregate Revolving Commitments.

(c) Protective Advances. Upon the occurrence and during the continuance of a Default or an Event of Default or upon the inability of the Borrower to satisfy the conditions to borrowing set forth in Section 4.01 after the Closing Date, the Administrative Agent, in its sole discretion, may make Revolving Loans to the Borrower on behalf of the Lenders, so long as the aggregate amount of such Revolving Loans shall not, together with the aggregate amount of all Overadvances then outstanding, exceed 10.0% of the then applicable Borrowing Base, if the Administrative Agent, in its Reasonable Credit Judgment, deems that such Revolving Loans are necessary or desirable (i) to protect all or any portion of the Collateral, (ii) to enhance the likelihood, or maximize the amount of, repayment of the Loans and the other Obligations, or (iii) to pay any other amount chargeable to the Borrower pursuant to this Agreement (such Revolving Loans, hereinafter, "Protective Advances"); provided, that (w) all Protective Advances shall be ABR Loans, (x) in no event shall the aggregate Revolving Facility Credit Exposure exceed the total Revolving Commitments of all Revolving Lenders, (y) the Required Lenders may at any time revoke the Administrative Agent's authorization to make future Protective Advances (provided; that existing Protective Advances shall not be subject to such revocation and any such revocation must be in writing and shall become effective prospectively upon the Administrative Agent's receipt thereof) and (z) unless otherwise consented to by each affected Lender, the Administrative Agent may not make Revolving Loans on behalf of the applicable Lenders under this Section 2.01(c) to the extent such Revolving Loans would cause a Lender's share of the Revolving Facility Credit Exposure to exceed such Lender's Revolving Commitment. Any Protective Advance made pursuant to the terms hereof shall be made by the Lenders ratably in accordance with their Revolving Facility Percentages.

(d) The making of any Agent Advance on any one occasion shall not obligate the Administrative Agent to make any Agent Advance on any other occasion. At any time that the conditions precedent set forth in Section 4.01 have been satisfied or waived, the Administrative Agent may request the Lenders to make a Revolving Loan to repay any Agent Advance. At any other time, the Administrative Agent may require the Lenders to fund their risk participations described in Section 2.01(e).

(e) Upon the making of any Agent Advance, each Lender shall be deemed, without further action by any party hereto, unconditionally and irrevocably to have purchased from the Administrative Agent, without recourse or warranty, an undivided interest and participation in such Agent Advance in proportion to their Revolving Facility Percentage. From and after the date, if any, on which any Lender is required to fund its participation in any Agent Advance purchased hereunder, the Administrative Agent shall promptly distribute to such Lender, such Lender's Revolving Facility Percentage of all payments of principal and interest and all proceeds of Collateral received by the Administrative Agent in respect of such Agent Advance.

Section 2.02 Loans and Borrowings. (a) Each Loan shall be made as part of a Borrowing consisting of Loans of the same Type made by the Lenders ratably in accordance with their respective Commitments (or, in the case of Swingline Loans, by the Swingline Lender in accordance with its Swingline Commitment). The failure of any Lender to make any Loan required to be made by it shall not relieve any other Lender of its obligations hereunder; provided, that the Commitments of the Lenders are several and no Lender shall be responsible for any other Lender's failure to make Loans as required.

(b) Subject to Section 2.14, each Borrowing (other than a Swingline Borrowing) shall be composed entirely of ABR Loans or Eurocurrency Loans as the Borrower may request in accordance herewith. Each Swingline Borrowing shall be an ABR Borrowing. Each Lender at its option may make any ABR Loan or Eurocurrency Loan by causing any domestic or foreign branch or Affiliate of such Lender to make such Loan; provided, that any exercise of such option shall not affect the obligation of the Borrower to repay such Loan in accordance with the terms of this Agreement and such Lender shall not be entitled to any amounts payable under Section 2.15 or 2.17 solely in respect of increased costs resulting from such exercise and existing at the time of such exercise.

(c) At the commencement of each Interest Period for any Eurocurrency Borrowing, such Borrowing shall be in an aggregate amount that is an integral multiple of the Borrowing Multiple and not less than the Borrowing Minimum. At the time that each ABR Borrowing is made, such Borrowing shall be in an aggregate amount that is an integral multiple of the Borrowing Multiple and not less than the Borrowing Minimum; provided, that an ABR Borrowing may be in an aggregate amount that is equal to the entire unused available balance of the Revolving Commitments, or that is required to finance the reimbursement of an L/C Disbursement as contemplated by Section 2.05(e). Each Swingline Borrowing shall be in an amount that is an integral multiple of the Borrowing Multiple and not less than the Borrowing Minimum. Borrowings of more than one Type may be outstanding at the same time; provided, that there shall not at any time be more than a total of 10 Eurocurrency Borrowings outstanding.

(d) Notwithstanding any other provision of this Agreement, the Borrower shall not be entitled to request, or to elect to convert or continue, any Borrowing of any Class if the Interest Period requested with respect thereto would end after the Maturity Date for such Class, as applicable.

Section 2.03 Requests for Borrowings. (a) To request a Borrowing, the Borrower shall notify the Administrative Agent of such request in writing (which may be via electronic mail or facsimile) (i) in the case of a Eurocurrency Borrowing, not later than 10:00 a.m., Local Time, three Business Days before the date of the proposed Borrowing or (ii) in the case of an ABR Borrowing, not later than 1:00 p.m., Local Time on the date of the proposed Borrowing provided, that, to request a Eurocurrency or ABR Borrowing on the Closing Date, the Borrower shall notify the Administrative Agent of such request by delivering a Borrowing Request not later than 2:00 p.m., Local Time, one Business Day prior to the Closing Date (or such later time as the Administrative Agent may agree). Each such request for a Borrowing shall be irrevocable and shall be confirmed promptly by hand delivery or electronic means to the Administrative Agent of a Borrowing Request in a form approved by the Administrative Agent and signed by the Borrower.

(b) Each such written notice and Borrowing Request shall specify the following information in compliance with Section 2.02:

- (i) whether such Borrowing is to be a Borrowing of Revolving Facility Loans or Extended Revolving Loans, as applicable;
- (ii) the aggregate amount of the requested Borrowing, which amount shall not result in the Revolving Facility Credit Exposure exceeding the Borrowing Base;
- (iii) the date of such Borrowing, which shall be a Business Day;
- (iv) whether such Borrowing is to be an ABR Borrowing or a Eurocurrency Borrowing;
- (v) in the case of a Eurocurrency Borrowing, the initial Interest Period to be applicable thereto, which shall be a period contemplated by the definition of the term "Interest Period"; and
- (vi) the location and number of the Borrower's account to which funds are to be disbursed.

If no election as to the Type of Borrowing is specified, then the requested Borrowing shall be an ABR Borrowing. If no Interest Period is specified with respect to any requested Eurocurrency Borrowing, then the Borrower shall be deemed to have selected an Interest Period of one month's duration. Promptly following receipt of a Borrowing Request in accordance with this Section 2.03, the Administrative Agent shall advise each Lender of the details thereof and of the amount of such Lender's Loan to be made as part of the requested Borrowing.

(c) Disbursement. The Borrower hereby irrevocably authorizes the Administrative Agent to disburse the proceeds of each Loan requested pursuant to this Section 2.03. The proceeds of each Loan requested under this Section 2.03 shall be disbursed by the Administrative Agent in Dollars in immediately available funds by wire transfer to such bank account as may be agreed upon by the Borrower and the Administrative Agent from time to time or elsewhere if pursuant to a written direction from the Borrower. If at any time any Loan is funded in excess of the amount requested by the Borrower, the Borrower agrees to repay the excess to the Administrative Agent promptly upon the earlier to occur of (a) the Borrower's discovery of the error and (b) notice thereof to the Borrower from the Administrative Agent or any applicable Lender.

Section 2.04 Swingline Loans. (a) Subject to the terms and conditions set forth herein, the Swingline Lender agrees to make Swingline Loans, in Dollars to the Borrower from time to time during the Availability Period, in an aggregate principal amount at any time outstanding that will not result in (i) the aggregate principal amount of outstanding Swingline Loans exceeding the Swingline Commitment or (ii) the aggregate Revolving Facility Credit Exposure of all Revolving Lenders exceeding Maximum Availability; provided, that the Swingline Lender shall not be required to make a Swingline Loan to refinance an outstanding Swingline Borrowing. Within the foregoing limits and subject to the terms and conditions set forth herein, the Borrower may borrow, prepay and reborrow Swingline Loans.

(b) To request a Swingline Borrowing, the Borrower shall notify the Administrative Agent and the Swingline Lender of such request in writing (which may be via electronic mail or facsimile) (confirmed by a Swingline Borrowing Request by electronic means), not later than 12:00 p.m., Local Time, on the day of a proposed Swingline Borrowing. Each such notice and Swingline Borrowing Request shall be irrevocable and shall specify (i) the requested date (which shall be a Business Day) and (ii) the amount of the requested Swingline Borrowing. The Swingline Lender shall consult with the Administrative Agent as to whether the making of the Swingline Loan is in accordance with the terms of this Agreement prior to the Swingline Lender funding such Swingline Loan. The Swingline Lender shall make each Swingline Loan in accordance with Section 2.02(a) on the proposed date thereof by wire transfer of immediately available funds to the account of the Borrower (or, in the case of a Swingline Borrowing made to finance the reimbursement of an L/C Disbursement as provided in Section 2.05(e), by remittance to the applicable Issuing Bank).

(c) The Swingline Lender may by written notice given to the Administrative Agent not later than 10:00 a.m., Local Time, on any Business Day require the Lenders to acquire participations on such Business Day in all or a portion of the outstanding Swingline Loans made by it. Such notice shall specify the aggregate amount of such Swingline Loans in which the Lenders will participate. Promptly upon receipt of such notice, the Administrative Agent will give notice thereof to each such Lender, specifying in such notice such Lender's Revolving Facility Percentage of such Swingline Loan or Loans. Each Lender hereby absolutely and unconditionally agrees, upon receipt of notice as provided above, to pay to the Administrative Agent for the account of the Swingline Lender, such Lender's Revolving Facility Percentage of such Swingline Loan. Each Lender acknowledges and agrees that its respective obligation to acquire participations in Swingline Loans pursuant to this paragraph is absolute and unconditional and shall not be affected by any circumstance whatsoever, including the occurrence and continuance of a Default or Event of Default or reduction or termination of the Commitments, and that each such payment shall be made without any offset, abatement, withholding or reduction whatsoever. Each Lender shall comply with its obligation under this paragraph by wire transfer of immediately available funds, in the same manner as provided in Section 2.06 with respect to Loans made by such Lender (and Section 2.06 shall apply, mutatis mutandis, to the payment obligations of the Lenders), and the Administrative Agent shall promptly pay to the Swingline Lender the amounts so received by it from the Lenders. The Administrative Agent shall notify the Borrower of any participations in any Swingline Loan acquired pursuant to this paragraph (c), and thereafter payments in respect of such Swingline Loan shall be made to the Administrative Agent and not to the Swingline Lender. Any amounts received by the Swingline Lender from the Borrower (or other party on behalf of the Borrower) in respect of a Swingline Loan after receipt by the Swingline Lender of the proceeds of a sale of participations therein shall be promptly remitted to the Administrative Agent; any such amounts received by the Administrative Agent shall be promptly remitted by the Administrative Agent to the Lenders that shall have made their payments pursuant to this paragraph and to the Swingline Lender, as their interests may appear; provided, that any such payment so remitted shall be repaid to the Swingline Lender or to the Administrative Agent, as applicable, if and to the extent such payment is required to be refunded to the Borrower for any reason. The purchase of participations in a Swingline Loan pursuant to this paragraph shall not relieve the Borrower of any default in the payment thereof.



(d) The Administrative Agent, the Swingline Lender and the Lenders agree (which agreement shall not be for the benefit of or enforceable by the Borrower) that in order to facilitate the administration of this Agreement and the other Loan Documents, settlement among them as to the Revolving Loans and the Swingline Loans and the Agent Advances shall take place on a periodic basis in accordance with the following provisions:

(i) The Administrative Agent shall request settlement (a "Settlement") with the Lenders on at least a weekly basis, or on a more frequent basis if so determined by the Administrative Agent, (A) on behalf of the Swingline Lender, with respect to each outstanding Swingline Loan, (B) for itself, with respect to each Agent Advance, and (C) with respect to collections received, in each case, by notifying the Lenders of such requested Settlement by facsimile, telephone, or other similar form of transmission, of such requested Settlement, no later than 12:00 noon, Local Time, on the date of such requested Settlement (the "Settlement Date"). Each Lender (other than the Swingline Lender, in the case of Swingline Loans, and the Administrative Agent, in the case of Agent Advances) shall make the amount of such Lender's Revolving Facility Percentage of the outstanding principal amount of the Swingline Loans and Agent Advances with respect to which Settlement is requested available to the Administrative Agent, to such account of the Administrative Agent as the Administrative Agent may designate, not later than 3:00 p.m., Local Time, on the Settlement Date applicable thereto, which may occur before or after the occurrence or during the continuation of a Default or an Event of Default and whether or not the applicable conditions precedent set forth in Article IV have then been satisfied. Such amounts made available to the Administrative Agent shall be applied against the amounts of the applicable Swingline Loan or Agent Advance and, together with the portion of such Swingline Loan or Agent Advance representing the Swingline Lender's or Administrative Agent's Revolving Facility Percentage thereof, shall constitute Revolving Facility Loans of the Lenders. If any such amount is not made available to the Administrative Agent by any Lender on the Settlement Date applicable thereto, the Administrative Agent shall, on behalf of the Swingline Lender with respect to each outstanding Swingline Loan and for itself with respect to each Agent Advance, be entitled to recover such amount on demand from such Lender together with interest thereon at the Federal Funds Effective Rate for the first three days from and after the Settlement Date and thereafter at the interest rate then applicable to ABR Loans.

(ii) Notwithstanding the foregoing, not more than one Business Day after demand is made by the Administrative Agent (whether before or after the occurrence of a Default or an Event of Default and regardless of whether the Administrative Agent has requested a Settlement with respect to a Swingline Loan or Agent Advance), each Lender (A) shall irrevocably and unconditionally purchase and receive from the Swingline Lender or the Administrative Agent, as the case may be, without recourse or warranty, an undivided interest and participation in such Swingline Loan or Agent Advance equal to such Lender's Revolving Facility Percentage of such Swingline Loan or Agent Advance and (B) if Settlement has not previously occurred with respect to such Swingline Loans or Agent Advances, upon demand by the Swingline Lender or the Administrative Agent, as the case may be, shall pay to the Swingline Lender or Administrative Agent, as applicable, as the purchase price of such participation an amount equal to one hundred percent (100%) of such Lender's Revolving Facility Percentage of such Swingline Loans or Agent Advances. If such amount is not in fact made available to the Administrative Agent by any Lender, the Administrative Agent shall be entitled to recover such amount on demand from such Lender together with interest thereon at the Federal Funds Effective Rate for the first three days from and after such demand and thereafter at the interest rate then applicable to ABR Loans.

(iii) From and after the date, if any, on which any Lender purchases an undivided interest and participation in any Swingline Loan or Agent Advance pursuant to clause (ii) preceding, the Administrative Agent shall promptly distribute to such Lender such Lender's Revolving Facility Percentage of all payments of principal and interest and all proceeds of Collateral received by the Administrative Agent in respect of such Swingline Loan or Agent Advance.

(iv) Between Settlement Dates, to the extent no Agent Advances are outstanding, the Administrative Agent may pay over to the Swingline Lender any payments received by the Administrative Agent, which in accordance with the terms of this Agreement would be applied to the reduction of the Revolving Loans, for application to the Swingline Lender's Revolving Loans or Swingline Loans. If, as of any Settlement Date, collections received since the then immediately preceding Settlement Date have been applied to the Swingline Lender's Revolving Loans, the Swingline Lender shall pay to the Administrative Agent for the accounts of the Lenders, to be applied to the outstanding Revolving Loans of such Lenders, an amount such that each Lender shall, upon receipt of such amount, have, as of such Settlement Date, its Revolving Facility Percentage of the Revolving Loans. During the period between Settlement Dates, the Swingline Lender with respect to Swingline Loans, the Administrative Agent with respect to Agent Advances, and each Revolving Lender with respect to the Revolving Loans, shall be entitled to interest at the applicable rate or rates payable under this Agreement on the actual average daily amount of funds employed by the Swingline Lender, the Administrative Agent and the Revolving Lenders.

Section 2.05 Letters of Credit. (a) General. Subject to the terms and conditions set forth herein, the Borrower may request the issuance of one or more letters of credit in U.S. Dollars issued for any lawful purposes of the Borrower and its Subsidiaries (such letters of credit issued for such purposes, "Letters of Credit") for its own account in a form reasonably acceptable to the applicable Issuing Bank, at any time and from time to time during the Availability Period and prior to the date that is five Business Days prior to the Maturity Date; provided, that no Issuing Bank shall be required to issue any Letter of Credit other than standby Letters of Credit. In the event of any inconsistency between the terms and conditions of this Agreement and the terms and conditions of any form of letter of credit application or other agreement submitted by the Borrower to, or entered into by the Borrower with, an Issuing Bank relating to any Letter of Credit, the terms and conditions of this Agreement shall control; provided, that the Issuing Bank shall not be required to issue any Letter of Credit in its reasonable discretion if any Lender is at such time a Defaulting Lender hereunder, unless the Issuing Bank has entered into satisfactory arrangements with the Borrower or such Lender to eliminate the Issuing Bank's risk of full reimbursement with respect to such Letter of Credit.

(b) Notice of Issuance, Amendment, Renewal, Extension: Certain Conditions. To request the issuance of a Letter of Credit (or the amendment, renewal (other than an automatic extension in accordance with paragraph (c) of this Section) or extension of an outstanding Letter of Credit), the Borrower shall hand deliver or fax (or transmit by electronic

communication, if arrangements for doing so have been approved by the applicable Issuing Bank) to the applicable Issuing Bank and the Administrative Agent (three Business Days in advance of the requested date of issuance, amendment or extension or such shorter period as the Administrative Agent and the Issuing Bank in their sole discretion may agree) a notice requesting the issuance of a Letter of Credit, or identifying the Letter of Credit to be amended or extended, and specifying the date of issuance, amendment or extension (which shall be a Business Day), the date on which such Letter of Credit is to expire (which shall comply with paragraph (c) of this Section), the amount of such Letter of Credit, the name and address of the beneficiary thereof and such other information as shall be necessary to issue, amend or extend such Letter of Credit. If requested by the applicable Issuing Bank, the Borrower also shall submit a letter of credit application on such Issuing Bank's standard form in connection with any request for a Letter of Credit. A Letter of Credit shall be issued, amended or extended only if (and upon issuance, amendment or extension of each Letter of Credit the Borrower shall be deemed to represent and warrant that), after giving effect to such issuance, amendment or extension (i) the total Revolving L/C Exposure shall not exceed the Letter of Credit Sublimit, (ii) the aggregate Revolving Facility Credit Exposure of all Revolving Lenders shall not exceed the total Revolving Commitments and (iii) the aggregate Revolving Facility Credit Exposure of all Revolving Lenders shall not exceed the Borrowing Base.

(c) Expiration Date. Each Letter of Credit shall expire at or prior to the close of business on the earlier of (i) the date one year (unless otherwise agreed upon by the Borrower and the Issuing Bank in their sole discretion) after the date of the issuance of such Letter of Credit (or, in the case of any renewal or extension thereof, one year (unless otherwise agreed upon by the Administrative Agent and the Issuing Bank in their sole discretion) after such renewal or extension) and (ii) the date that is five Business Days prior to the Maturity Date; provided, that any Letter of Credit with one year tenor may provide for automatic renewal or extension thereof for additional one year periods (which, in no event, shall extend beyond the date referred to in clause (ii) of this paragraph (c)) so long as such Letter of Credit permits the Issuing Bank to prevent any such extension at least once in each twelve-month period (commencing with the date of issuance of such Letter of Credit) by giving prior notice to the beneficiary thereof within a time period during such twelve-month period to be agreed upon at the time such Letter of Credit is issued; provided, further, that if the Issuing Bank and the Administrative Agent each consent in their sole discretion, the expiration date on any Letter of Credit may extend beyond the date referred to in clause (ii) above; provided, that (x) if any such Letter of Credit is outstanding or the expiration date is extended to a date that is later than five Business Days prior to the Maturity Date the Borrower shall Cash Collateralize each such Letter of Credit in an amount equal to the Minimum L/C Collateral Amount on or prior to the date that is five Business Days prior to the Maturity Date or, if later, such date of issuance and (y) each Lender's participation in any undrawn Letter of Credit that is outstanding on the Maturity Date shall terminate on the Maturity Date.

(d) Participations. By the issuance of a Letter of Credit (or an amendment to a Letter of Credit increasing the amount thereof) and without any further action on the part of the applicable Issuing Bank or the Lenders, such Issuing Bank hereby grants to each Lender, and each Lender hereby acquires from such Issuing Bank, a participation in such Letter of Credit equal to such Lender's Revolving Facility Percentage of the aggregate amount

available to be drawn under such Letter of Credit. In consideration and in furtherance of the foregoing, each Lender hereby absolutely and unconditionally agrees to pay to the Administrative Agent, for the account of the Issuing Bank, in Dollars, such Lender's Revolving Facility Percentage of each L/C Disbursement made by such Issuing Bank and not reimbursed by the Borrower on the date due as provided in paragraph (e) of this Section, or of any reimbursement payment required to be refunded to the Borrower for any reason. Each Lender acknowledges and agrees that its obligation to acquire participations pursuant to this paragraph in respect of Letters of Credit is absolute and unconditional and shall not be affected by any circumstance whatsoever, including any amendment, renewal or extension of any Letter of Credit or the occurrence and continuance of a Default or Event of Default or reduction or termination of the Commitments, and that each such payment shall be made without any offset, abatement, withholding or reduction whatsoever.

(e) Reimbursement. If the applicable Issuing Bank shall make any L/C Disbursement in respect of a Letter of Credit, the Borrower shall reimburse such L/C Disbursement by paying to the Administrative Agent an amount in Dollars equal to such L/C Disbursement not later than 2:00 p.m., Local Time, on the first Business Day after the Borrower receives notice under paragraph (g) of this Section of such L/C Disbursement (or the second Business Day, if such notice is received after noon, Local Time), together with accrued interest thereon from the date of such L/C Disbursement at the rate applicable to ABR Loans; provided, that the Borrower may, subject to the conditions to borrowing set forth herein, request in accordance with Section 2.03 or 2.04 that such payment be financed with an ABR Borrowing or a Swingline Borrowing, as applicable, in an equivalent amount and, to the extent so financed, the Borrower's obligation to make such payment shall be discharged and replaced by the resulting ABR Borrowing or Swingline Borrowing. If the Borrower fails to reimburse any L/C Disbursement when due, then the Administrative Agent shall promptly notify the applicable Issuing Bank and each other Lender of the applicable L/C Disbursement, the payment then due from the Borrower in respect thereof and, in the case of a Lender, such Lender's Revolving Facility Percentage. Promptly following receipt of such notice, each Lender shall pay to the Administrative Agent in Dollars its Revolving Facility Percentage of the payment then due from the Borrower in the same manner as provided in Section 2.06 with respect to Loans made by such Lender (and Section 2.06 shall apply, mutatis mutandis, to the payment obligations of the Lenders), and the Administrative Agent shall promptly pay to the applicable Issuing Bank the amounts so received by it from the Lenders. Promptly following receipt by the Administrative Agent of any payment from the Borrower pursuant to this paragraph, the Administrative Agent shall distribute such payment to the applicable Issuing Bank or, to the extent that Lenders have made payments pursuant to this paragraph to reimburse such Issuing Bank, then to such Lenders and such Issuing Bank as their interests may appear. Any payment made by a Lender pursuant to this paragraph to reimburse an Issuing Bank for any L/C Disbursement (other than the funding of an ABR Borrowing for Revolving Loans or a Swingline Borrowing as contemplated above) shall not constitute a Loan and shall not relieve the Borrower of its obligation to reimburse such L/C Disbursement.

(f) Obligations Absolute. The obligation of the Borrower to reimburse L/C Disbursements as provided in paragraph (e) of this Section shall be absolute, unconditional and irrevocable, and shall be performed strictly in accordance with the terms of this Agreement under any and all circumstances whatsoever and irrespective of (i) any lack of validity or enforceability of any Letter of Credit or this Agreement, or any term or provision therein, (ii) any draft or other document presented under a Letter of Credit proving to be forged, fraudulent or invalid in any respect or any statement therein being untrue or inaccurate in any respect, (iii) payment by the applicable Issuing Bank under a Letter of Credit against presentation of a draft or other document that does not comply with the terms of such Letter of Credit or (iv) any other event or circumstance whatsoever, whether or not similar to any of the foregoing, that might, but for the provisions of this Section, constitute a legal or equitable discharge of, or provide a right of set-off against, the Borrower's obligations hereunder. Neither the Administrative Agent, the Lenders nor any Issuing Bank, nor any of their Related Parties, shall have any liability or responsibility by reason of or in connection with the issuance or transfer of any Letter of Credit or any payment or failure to make any payment thereunder (irrespective of any of the circumstances referred to in the preceding sentence), or any error, omission, interruption, loss or delay in transmission or delivery of any draft, notice or other communication under or relating to any Letter of Credit (including any document required to make a drawing thereunder), any error in interpretation of technical terms or any consequence arising from causes beyond the control of such Issuing Bank, or any of the circumstances referred to in clauses (i), (ii) or (iii) of the first sentence; provided, that the foregoing shall not be construed to excuse such Issuing Bank from liability to the Borrower to the extent of any direct damages (as opposed to consequential damages, claims in respect of which are hereby waived by the Borrower to the extent permitted by applicable law) suffered by the Borrower that are determined by a final and binding decision of a court of competent jurisdiction to have been caused by such Issuing Bank's gross negligence or willful misconduct when determining whether drafts and other documents presented under a Letter of Credit comply with the terms thereof. In furtherance of the foregoing and without limiting the generality thereof, the parties agree that, with respect to documents presented which appear on their face to be in substantial compliance with the terms of a Letter of Credit, the applicable Issuing Bank may, in its sole discretion, either accept and make payment upon such documents without responsibility for further investigation, regardless of any notice or information to the contrary, or refuse to accept and make payment upon such documents if such documents are not in strict compliance with the terms of such Letter of Credit.

(g) Disbursement Procedures. The applicable Issuing Bank shall, promptly following its receipt thereof, examine all documents purporting to represent a demand for payment under a Letter of Credit. Such Issuing Bank shall promptly notify the Administrative Agent and the Borrower by telephone (confirmed by electronic means) or electronic means of any such demand for payment under a Letter of Credit and whether such Issuing Bank has made or will make a L/C Disbursement thereunder; provided, that any failure to give or delay in giving such notice shall not relieve the Borrower of its obligation to reimburse such Issuing Bank and/or the Lenders with respect to any such L/C Disbursement.

(h) Interim Interest. If an Issuing Bank shall make any L/C Disbursement, then, unless the Borrower shall reimburse such L/C Disbursement in full on the date such L/C Disbursement is made, the unpaid amount thereof shall bear interest, for each day from and including the date such L/C Disbursement is made to but excluding the date that the Borrower reimburses such L/C Disbursement, at the rate per annum then applicable to ABR

Loans; provided, that, if such L/C Disbursement is not reimbursed by the Borrower when due pursuant to paragraph (e) of this Section, then Section 2.13(c) shall apply. Interest accrued pursuant to this paragraph shall be for the account of the applicable Issuing Bank, except that interest accrued on and after the date of payment by any Lender pursuant to paragraph (e) of this Section to reimburse such Issuing Bank shall be for the account of such Lender to the extent of such payment.

(i) Replacement of an Issuing Bank. An Issuing Bank may be replaced at any time by written agreement among the Borrower, the Administrative Agent, the replaced Issuing Bank and the successor Issuing Bank. The Administrative Agent shall notify the Lenders of any such replacement of an Issuing Bank. At the time any such replacement shall become effective, the Borrower shall pay all unpaid fees accrued for the account of the replaced Issuing Bank pursuant to Section 2.12. From and after the effective date of any such replacement, (i) the successor Issuing Bank shall have all the rights and obligations of the replaced Issuing Bank under this Agreement with respect to Letters of Credit to be issued thereafter and (ii) references herein to the term "Issuing Bank" shall be deemed to refer to such successor or to any previous Issuing Bank, or to such successor and all previous Issuing Banks, as the context shall require. After the replacement of an Issuing Bank hereunder, the replaced Issuing Bank shall remain a party hereto and shall continue to have all the rights and obligations of such Issuing Bank under this Agreement with respect to Letters of Credit issued by it prior to such replacement but shall not be required to issue additional Letters of Credit.

(j) Cash Collateralization Following Certain Events. If and when the Borrower is required to Cash Collateralize any Revolving L/C Exposure relating to any outstanding Letters of Credit pursuant to any of Section 2.11(b), 2.11(c), 2.22(a)(v) or 7.01, the Borrower shall deposit in an account with or at the direction of the Collateral Agent, in the name of the Collateral Agent and for the benefit of the Lenders, an amount in cash in Dollars equal to the Revolving L/C Exposure as of such date (or, in the case of Sections 2.11(b), 2.11(c) and 2.22(a)(v), the portion thereof required by such sections). Each deposit of Cash Collateral (x) made pursuant to this paragraph, (y) made by the Administrative Agent under Section 5.11(b) during the continuation of an Event of Default or (z) made by the Administrative Agent pursuant Section 2.18(b) or 2.22(a)(ii), in each case, shall be held by the Collateral Agent as collateral for the payment and performance of the obligations of the Borrower under this Agreement. The Collateral Agent shall have exclusive dominion and control, including the exclusive right of withdrawal, over such account. Such deposits shall not bear interest, other than any interest earned on the investment of such deposits, which investments shall be made at the option and sole discretion of (i) for so long as an Event of Default shall be continuing, the Collateral Agent and (ii) at any other time, the Borrower, in each case, in Permitted Investments and at the risk and expense of the Borrower. Interest or profits, if any, on such investments shall accumulate in such account. Moneys in such account shall be applied by the Collateral Agent to reimburse each Issuing Bank for L/C Disbursements for which such Issuing Bank has not been reimbursed and, to the extent not so applied, shall be held for the satisfaction of the reimbursement obligations of the Borrower for the Revolving L/C Exposure at such time or, if the maturity of the Loans has been accelerated (but subject to the consent of Lenders with Revolving L/C Exposure representing greater than 50% of the total Revolving L/C Exposure), be applied to satisfy other obligations of the Borrower under this Agreement. If the Borrower is required to

provide an amount of Cash Collateral hereunder as a result of the occurrence of an Event of Default or the existence of a Defaulting Lender or the occurrence of a limit under Section 2.11(b) or (c) being exceeded, such amount (to the extent not applied as aforesaid) shall be returned to the Borrower within three Business Days after all Events of Default have been cured or waived or the termination of the Defaulting Lender status or the limits under Sections 2.11(b) and (c) no longer being exceeded, as applicable.

(k) Cash Collateralization Following Termination and Prepayment of the Facility. Notwithstanding anything to the contrary herein, in the event of the prepayment in full of all outstanding Revolving Loans and the termination of all Revolving Commitments by the Borrower pursuant to Section 2.08(b) (a "Facility Termination Event") in connection with which the Borrower notifies any one or more Issuing Banks that it intends to maintain one or more Letters of Credit initially issued under this Agreement in effect after the date of such Facility Termination Event (each, a "Continuing Letter of Credit"), then the security interest of the Collateral Agent in the Collateral under the Security Documents may be terminated in accordance with Section 9.18 if each such Continuing Letter of Credit is Cash Collateralized in an amount equal to the Minimum L/C Collateral Amount, which shall be deposited with or at the direction of each such Issuing Bank.

(l) Additional Issuing Banks. From time to time, the Borrower may by notice to the Administrative Agent designate any Lender each of which agrees (in its sole discretion) to act in such capacity and that is reasonably satisfactory to the Administrative Agent as an Issuing Bank. Each such additional Issuing Bank shall execute a counterpart of this Agreement upon the approval of the Administrative Agent (which approval shall not be unreasonably withheld) and shall thereafter be an Issuing Bank hereunder for all purposes.

(m) Reporting. Unless otherwise requested by the Administrative Agent, each Issuing Bank shall (i) provide to the Administrative Agent copies of any notice received from the Borrower pursuant to Section 2.05(b) no later than the next Business Day after receipt thereof and (ii) report in writing to the Administrative Agent (A) on or prior to each Business Day on which such Issuing Bank expects to issue, amend or extend any Letter of Credit, the date of such issuance, amendment or extension, and the aggregate face amount of the Letters of Credit to be issued, amended or extended by it and outstanding after giving effect to such issuance, amendment or extension occurred (and whether the amount thereof changed), and the Issuing Bank shall be permitted to issue, amend or extend such Letter of Credit if the Administrative Agent shall not have advised the Issuing Bank that such issuance, amendment or extension would not be in conformity with the requirements of this Agreement, (B) on each Business Day on which such Issuing Bank makes any L/C Disbursement, the date of such L/C Disbursement and the amount of such L/C Disbursement and (C) on any other Business Day, such other information with respect to the outstanding Letters of Credit issued by such Issuing Bank as the Administrative Agent shall reasonably request.

(n) No Liability of the Issuing Bank. The Borrower assumes all risks of the acts or omissions of any beneficiary or transferee of any Letter of Credit with respect to its use of such Letter of Credit. Neither any Issuing Bank nor any of its officers or directors shall be liable or responsible for: (a) the use that may be made of any Letter of Credit or any acts or

omissions of any beneficiary or transferee in connection therewith; (b) the validity, sufficiency or genuineness of documents, or of any endorsement thereon, even if such documents should prove to be in any or all respects invalid, insufficient, fraudulent or forged; (c) payment by such Issuing Bank against presentation of documents that do not comply with the terms of a Letter of Credit, including failure of any documents to bear any reference or adequate reference to the Letter of Credit; or (d) any other circumstances whatsoever in making or failing to make payment under any Letter of Credit, except that the Borrower shall have a claim against such Issuing Bank, and such Issuing Bank shall be liable to the Borrower, to the extent of any direct, but not consequential, damages suffered by the Borrower that the Borrower proves were caused by (i) such Issuing Bank's willful misconduct or gross negligence as determined in a final, non-appealable judgment by a court of competent jurisdiction in determining whether documents presented under any Letter of Credit comply with the terms of the Letter of Credit or (ii) such Issuing Bank's willful failure to make lawful payment under a Letter of Credit after the presentation to it of a draft and certificates strictly complying with the terms and conditions of the Letter of Credit. In furtherance and not in limitation of the foregoing, such Issuing Bank may accept documents that appear on their face to be in order, without responsibility for further investigation, regardless of any notice or information to the contrary.

Section 2.06 Funding of Borrowings. (a) Each Lender shall make each Loan to be made by it hereunder on the proposed date thereof by wire transfer of immediately available funds by 2:00 p.m., Local Time, to the account of the Administrative Agent most recently designated by it for such purpose by notice to the Lenders; provided, that Swingline Loans shall be made as provided in Section 2.04. The Administrative Agent will make such Loans available to the Borrower by promptly crediting the amounts so received, in like funds, to an account of the Borrower as specified in the applicable Borrowing Request; provided, that ABR Loans and Swingline Borrowings made to finance the reimbursement of a L/C Disbursement and reimbursements as provided in Section 2.05(e) shall be remitted by the Administrative Agent to the applicable Issuing Bank.

(b) Unless the Administrative Agent shall have received notice from a Lender prior to the proposed date of any Borrowing that such Lender will not make available to the Administrative Agent such Lender's share of such Borrowing, the Administrative Agent may assume that such Lender has made such share available on such date in accordance with clause (a) of this Section and may, in reliance upon such assumption, make available to the Borrower a corresponding amount. In such event, if a Lender has not in fact made its share of the Borrowing available to the Administrative Agent, then the applicable Lender and the Borrower severally agree to pay to the Administrative Agent forthwith on demand (without duplication) such corresponding amount with interest thereon, for each day from and including the date such amount is made available to the Borrower to but excluding the date of payment to the Administrative Agent, at (i) in the case of a payment to be made by such Lender, the greater of (A) the Federal Funds Effective Rate and (B) a rate determined by the Administrative Agent in accordance with banking industry rules on interbank compensation or (ii) in the case of a payment to be made by the Borrower, the interest rate applicable to ABR Loans at such time. If the Borrower and such Lender shall pay such interest to the Administrative Agent for the same or an overlapping period, the Administrative Agent shall promptly remit to the Borrower the amount of such interest paid by the Borrower for such period. If such Lender pays such amount to the Administrative Agent, then such amount shall constitute such Lender's Loan included in such Borrowing. Any payment by the Borrower shall be without prejudice to any claim the Borrower may have against a Lender that shall have failed to make such payment to the Administrative Agent.



(c) The foregoing notwithstanding, the Administrative Agent, in its sole discretion, may from its own funds make a Revolving Loan on behalf of the Lenders (including by means of Swingline Loans to the Borrower). In such event, the applicable Lenders on behalf of whom the Administrative Agent made the Revolving Loan shall reimburse the Administrative Agent for all or any portion of such Revolving Loan made on its behalf upon written notice given to each applicable Lender not later than 2:00 p.m., Local Time, on the Business Day such reimbursement is requested. On each such settlement date, the Administrative Agent will pay to each such Lender the net amount owing to such Lender in connection with such settlement, including amounts relating to Loans, fees, interest and other amounts payable hereunder. The entire amount of interest attributable to such Revolving Loan for the period from and including the date on which such Revolving Loan was made on such Lender's behalf to but excluding the date the Administrative Agent is reimbursed in respect of such Revolving Loan by such Lender shall be paid to the Administrative Agent for its own account.

Section 2.07 Interest Elections. (a) Each Borrowing initially shall be of the Type specified in the applicable Borrowing Request and, in the case of a Eurocurrency Borrowing, shall have an initial Interest Period as specified in such Borrowing Request. Thereafter, the Borrower may elect to convert such Borrowing to a different Type or to continue such Borrowing and, in the case of a Eurocurrency Borrowing, may elect Interest Periods therefor, all as provided in this Section. The Borrower may elect different options with respect to different portions of the affected Borrowing, in which case each such portion shall be allocated ratably among the Lenders holding the Loans comprising such Borrowing, and the Loans comprising each such portion shall be considered a separate Borrowing. This Section shall not apply to Swingline Borrowings and Agent Advances, which may not be converted or continued.

(b) To make an election pursuant to this Section, the Borrower shall notify the Administrative Agent of such election in writing (which may be via electronic mail or facsimile), by the time that a Borrowing Request would be required under Section 2.03 if the Borrower were requesting a Borrowing of the Type resulting from such election to be made on the effective date of such election. Each such election request shall be irrevocable and shall be confirmed promptly by hand delivery or electronic means to the Administrative Agent of a written Interest Election Request in the form of Exhibit E and signed by the Borrower.

(c) Each such election request and Interest Election Request shall specify the following information in compliance with Section 2.02:

(i) the Borrowing to which such Interest Election Request applies and, if different options are being elected with respect to different portions thereof, the portions thereof to be allocated to each resulting Borrowing (in which case the information to be specified pursuant to clauses (iii) and (iv) below shall be specified for each resulting Borrowing);

(ii) the effective date of the election made pursuant to such Interest Election Request, which shall be a Business Day;

(iii) whether the resulting Borrowing is to be an ABR Borrowing or a Eurocurrency Borrowing; and

(iv) if the resulting Borrowing is a Eurocurrency Borrowing, the Interest Period to be applicable thereto after giving effect to such election, which shall be a period contemplated by the definition of the term "Interest Period."

If any such Interest Election Request requests a Eurocurrency Borrowing but does not specify an Interest Period, then the Borrower shall be deemed to have selected an Interest Period of one month's duration.

(d) Promptly following receipt of an Interest Election Request, the Administrative Agent shall advise each Lender to which such Interest Election Request relates of the details thereof and of such Lender's portion of each resulting Borrowing.

(e) If the Borrower fails to deliver a timely Interest Election Request with respect to a Eurocurrency Borrowing prior to the end of the Interest Period applicable thereto, then, unless such Borrowing is repaid as provided herein, at the end of such Interest Period such Borrowing shall be converted to an ABR Borrowing. Notwithstanding any contrary provision hereof, if an Event of Default has occurred and is continuing and the Administrative Agent, at the written request (including a request through electronic means) of the Required Lenders, so notifies the Borrower, then, so long as an Event of Default is continuing (i) no outstanding Borrowing may be converted to or continued as a Eurocurrency Borrowing and (ii) unless repaid, each Eurocurrency Borrowing shall be converted to an ABR Borrowing at the end of the Interest Period applicable thereto.

Section 2.08 Termination and Reduction of Commitments. (a) Unless previously terminated, the Commitments shall terminate on the date that is the earlier of (x) to the extent the Closing Date has not yet occurred on or prior to such date, the Outside Date and (y) the Maturity Date.

(b) The Borrower may at any time terminate, or from time to time reduce, the Revolving Commitments; provided, that (i) each reduction of the Revolving Commitments shall be in an amount that is an integral multiple of \$250,000 and not less than \$500,000 (or, if less, the remaining amount of the Revolving Commitments) and (ii) the Borrower shall not terminate or reduce the Revolving Commitments if, after giving effect to any concurrent prepayment of the Revolving Loans in accordance with Section 2.11 and any Cash Collateralization of Letters of Credit in accordance with Section 2.05(j) or (k), the Revolving Facility Credit Exposure (excluding any Cash Collateralized Letter of Credit) would exceed Maximum Availability.

(c) The Borrower shall notify the Administrative Agent of any election to terminate or reduce the Commitments under clause (b) of this Section at least three Business Days prior to the effective date of such termination or reduction, specifying such election and the effective date thereof. Promptly following receipt of any notice, the Administrative Agent shall advise the applicable Lenders of the contents thereof. Each notice delivered by the Borrower pursuant to this Section shall be irrevocable; provided, that a notice of termination or reduction of the Revolving Commitments delivered by the Borrower may state that such notice is conditioned on the effectiveness of other credit facilities, indentures or similar agreements or other transactions, in which case such notice may be revoked by the Borrower (by notice to the Administrative Agent on or prior to the specified effective date) if such condition is not satisfied. Any termination or reduction of the Commitments shall be permanent. Each reduction of the Commitments shall be made ratably among the Lenders in accordance with their respective Commitments.

Section 2.09 Repayment of Loans; Evidence of Debt. (a) The Borrower hereby unconditionally promises to pay (i) to the Administrative Agent for the account of each Lender the then unpaid principal amount of each Revolving Loan, Protective Advance and Overadvance to the Borrower on the Maturity Date and (ii) to the Swingline Lender the then unpaid principal amount of each Swingline Loan on the Maturity Date.

(b) Each Lender shall maintain in accordance with its usual practice an account or accounts evidencing the indebtedness of the Borrower to such Lender resulting from each Loan made by such Lender, including the amounts of principal and interest payable and paid to such Lender from time to time hereunder.

(c) The Administrative Agent, acting solely for this purpose as a non- fiduciary agent of the Borrower, shall maintain the Register pursuant to Section 9.04(b)(iv) in which shall be recorded (i) the amount of each Loan made hereunder, the Facility and Type thereof and the Interest Period (if any) applicable thereto, (ii) the amount of any principal or interest due and payable or to become due and payable from the Borrower to each Lender hereunder and (iii) any amount received by the Administrative Agent hereunder for the account of the Lenders and each Lender's share thereof.

(d) The entries made in the Register and the accounts of each Lender maintained pursuant to clause (b) or (c) of this Section shall be prima facie evidence of the existence and amounts of the obligations recorded therein; provided, that (i) the Register shall control in the event of any conflict between the Register entries and any such account and (ii) the failure of any Lender or the Administrative Agent to maintain such accounts or the Register, as applicable, or any error therein, shall not in any manner affect the obligation of the Borrower to repay the Loans in accordance with the terms of this Agreement.

(e) Any Lender may request that Loans made by it be evidenced by a promissory note (a "Note"). In such event, the Borrower shall prepare, execute and deliver to such Lender a promissory note payable to such Lender (or, if requested by such Lender, to such Lender and its registered assigns) and in a form approved by the Administrative Agent and reasonably acceptable to the Borrower. Thereafter, unless otherwise agreed to by the applicable Lender, the Loans evidenced by such promissory note and interest thereon shall at all times (including after assignment pursuant to Section 9.04) be represented by one or more promissory notes in such form payable to the payee named therein (or, if requested by such payee, to such payee and its registered assigns).

Section 2.10 Notice of Prepayment of Revolving Loans. Prior to any prepayment of any Revolving Loans pursuant to Section 2.11, the Borrower shall select the Borrowing or Borrowings to be repaid and shall notify the Administrative Agent in writing (which may be via electronic mail or facsimile) of such selection (a) in the case of an ABR Borrowing, not later than 10:00 a.m., Local Time at least one Business Day before the scheduled date of such prepayment and (b) in the case of a Eurocurrency Borrowing, not later than 2:00 p.m., Local Time at least three Business Days before the scheduled date of such prepayment; provided, that a notice of prepayment may state that such notice is conditioned upon the effectiveness of other credit facilities, indentures or similar agreements or other transactions, in which case such notice may be revoked by the Borrower (by notice to the Administrative Agent on or prior to the specified effective date) if such condition is not satisfied. Each repayment of a Borrowing shall be applied to the Revolving Loans included in the repaid Borrowing such that each Lender receives its ratable share of such repayment (based upon the respective Revolving Facility Credit Exposure of the applicable Lenders at the time of such repayment). Notwithstanding anything to the contrary in the immediately preceding sentence, prior to any repayment of a Swingline Loan hereunder, the Borrower shall select the Borrowing or Borrowings to be repaid and shall notify the Administrative Agent in writing (which may be via electronic mail or facsimile) of such selection not later than 12:00 p.m., Local Time, on the scheduled date of such repayment. Repayments of Eurocurrency Borrowings shall be accompanied by accrued interest on the amount repaid to the extent required by Section 2.13(d).

Section 2.11 Prepayment of Loans. (a) The Borrower shall have the right at any time and from time to time to prepay any Loan in whole or in part, without premium or penalty (but subject to Section 2.16), in an aggregate principal amount that is an integral multiple of the Borrowing Multiple and not less than the Borrowing Minimum or, if less, the amount outstanding, subject to prior notice in accordance with Section 2.10.

(b) Subject to Sections 2.01(b) and (c), in the event the aggregate amount of the Revolving Facility Credit Exposure exceeds Maximum Availability in effect at such time, then the Borrower shall promptly repay outstanding Revolving Loans and/or Cash Collateralize Revolving L/C Exposure in accordance with Section 2.05(j) in an aggregate amount equal to such excess.

(c) In the event and on such occasion as the Revolving L/C Exposure exceeds the Letter of Credit Sublimit, at the request of the Administrative Agent, the Borrower shall deposit Cash Collateral in an account with the Administrative Agent pursuant to Section 2.05(j) in an amount equal to such excess.

Section 2.12 Fees. (a) The Borrower agrees to pay to each Lender (other than any Defaulting Lender), through the Administrative Agent, on the date that is five Business Days after the last Business Day of March, June, September and December in each year, and three Business Days after the date on which the Commitments of all the Lenders shall be terminated as provided herein, a commitment fee (a "Commitment Fee") on the daily amount of the Available Unused Commitment of such Lender during the preceding quarter (or other period commencing with the Closing Date or ending with the date on which the last of the Commitments of such Lender shall be terminated) at a rate equal to the Applicable Commitment

Fee. All Commitment Fees shall be computed on the basis of the actual number of days elapsed in a year of 360 days. For the purpose of calculating any Lender's Commitment Fee, the outstanding Swingline Loans during the period for which such Lender's Commitment Fee is calculated shall be deemed to be zero. The Commitment Fee due to each Lender shall commence to accrue on the Closing Date and shall cease to accrue on the date on which the last of the Commitments of such Lender shall be terminated as provided herein.

(b) The Borrower from time to time agrees to pay (i) to each Lender (other than any Defaulting Lender), through the Administrative Agent, five Business Days after the last day of March, June, September and December of each year and three Business Days after the date on which the Commitments of all the Lenders shall be terminated as provided herein, a fee (an "L/C Participation Fee") on such Lender's Revolving Facility Percentage of the daily aggregate Revolving L/C Exposure (excluding the portion thereof attributable to unreimbursed L/C Disbursements), during the preceding quarter (or shorter period commencing with the Closing Date or ending with the Maturity Date or the date on which the Commitments shall be terminated) at the rate per annum equal to the Applicable Margin for Eurocurrency Borrowings effective for each day in such period and (ii) to each Issuing Bank, for its own account (x) five Business Days after the last Business Day of March, June, September and December of each year and three Business Days after the date on which the Commitments of all the Lenders shall be terminated as provided herein, a fronting fee in respect of each Letter of Credit issued by such Issuing Bank for the period from and including the date of issuance of such Letter of Credit to and including the termination of such Letter of Credit, computed at a rate equal to 1/8 of 1% per annum of the daily average stated amount of such Letter of Credit, plus (y) in connection with the issuance, amendment or transfer of any such Letter of Credit or any L/C Disbursement thereunder, such Issuing Bank's customary documentary and processing fees and charges (collectively, "Issuing Bank Fees"). All L/C Participation Fees and Issuing Bank Fees that are payable in Dollars on a per annum basis shall be computed on the basis of the actual number of days elapsed in a year of 360 days.

(c) The Borrower agrees to pay the agency fees to the Administrative Agent, for the account of the Administrative Agent (the "Administrative Agent Fees") set forth in the Fee Letter, as amended, restated, supplemented or otherwise modified from time to time, at the times specified therein.

(d) All Fees shall be paid on the dates due, in immediately available funds, to the Administrative Agent for distribution, if and as appropriate, among the Lenders, except that Issuing Bank Fees shall be paid directly to the applicable Issuing Banks. Once paid, such Fees shall not be refundable under any circumstances.

Section 2.13 Interest. (a) The Loans comprising each ABR Borrowing (including each Swingline Loan) shall bear interest at the ABR plus the Applicable Margin.

(b) The Loans comprising each Eurocurrency Borrowing shall bear interest at the Adjusted LIBOR Rate for the Interest Period in effect for such Borrowing plus the Applicable Margin.

(c) Notwithstanding the foregoing, if any principal of or interest on any Loan or any Fees or other amount payable by the Borrower hereunder is not paid when due, whether at stated maturity, upon acceleration or otherwise, such overdue amount shall bear interest, after as well as before judgment, at a rate per annum equal to (i) in the case of overdue principal of any Loan, 2.00% plus the rate otherwise applicable to such Loan as provided in the preceding clauses of this Section 2.13 or (ii) in the case of any other overdue amount, 2.00% plus the rate applicable to ABR Loans as provided in clause (a) of this Section; provided, that this clause (c) shall not apply to any Event of Default that has been waived by the Lenders pursuant to Section 9.08.

(d) Accrued interest on each Loan shall be payable in arrears (i) on each Interest Payment Date for such Loan and (ii) upon termination of the Commitments; provided, that (A) interest accrued pursuant to clause (c) of this Section 2.13 shall be payable on demand, (B) in the event of any repayment or prepayment of any Loan (other than an ABR Loan or Swingline Loan prior to the end of the Availability Period), accrued interest on the principal amount repaid or prepaid shall be payable on the date of such repayment or prepayment and (C) in the event of any conversion of any Eurocurrency Loan prior to the end of the current Interest Period therefor, accrued interest on such Loan shall be payable on the effective date of such conversion.

(e) All interest hereunder shall be computed on the basis of a year of 360 days, except that interest computed by reference to the ABR shall be computed on the basis of a year of 365 days (or 366 days in a leap year), and in each case shall be payable for the actual number of days elapsed (including the first day but excluding the last day). The applicable ABR, Adjusted LIBOR Rate or LIBOR Rate shall be determined by the Administrative Agent, and such determination shall be conclusive absent manifest error.

Section 2.14 Alternate Rate of Interest. If prior to the commencement of any Interest Period for a Eurocurrency Borrowing:

(a) the Administrative Agent determines (which determination shall be conclusive absent manifest error) that adequate and reasonable means do not exist for ascertaining the Adjusted LIBOR Rate for such Interest Period; or

(b) the Administrative Agent is advised by the Required Lenders that the Adjusted LIBOR Rate for such Interest Period will not adequately and fairly reflect the cost to such Lenders of making or maintaining their Loans included in such Borrowing for such Interest Period;

then the Administrative Agent shall give notice thereof to the Borrower and the Lenders by telephone or electronic means as promptly as practicable thereafter and, until the Administrative Agent notifies the Borrower and the Lenders that the circumstances giving rise to such notice no longer exist, (i) any Interest Election Request that requests the conversion of any Borrowing to, or continuation of any Borrowing as, a Eurocurrency Borrowing shall be ineffective and such Borrowing shall be converted to or continued as on the last day of the Interest Period applicable thereto an ABR Borrowing, and (ii) if any Borrowing Request requests a Eurocurrency Borrowing, such Borrowing shall be made as an ABR Borrowing.

Section 2.15 Increased Costs. (a) If any Change in Law shall:

(i) impose, modify or deem applicable any reserve, special deposit or similar requirement against assets of, deposits with or for the account of, or credit extended by, any Lender (except any such reserve requirement reflected in the Adjusted LIBOR Rate) or Issuing Bank;

(ii) subject any Lender to any Tax with respect to any Loan Document or any Eurocurrency Loan made by it (other than (i) Taxes indemnifiable under Section 2.17 or (ii) Excluded Taxes); or

(iii) impose on any Lender or Issuing Bank or the London interbank market any other condition affecting this Agreement or Eurocurrency Loans made by such Lender or any Letter of Credit or participation therein;

and the result of any of the foregoing shall be to increase the cost to such Lender of making or maintaining any Eurocurrency Loan (or of maintaining its obligation to make any such Loan) or to increase the cost to such Lender or Issuing Bank of participating in, issuing or maintaining any Letter of Credit or to reduce the amount of any sum received or receivable by such Lender or Issuing Bank hereunder (whether of principal, interest or otherwise), then the Borrower will pay to such Lender or Issuing Bank, as applicable, such additional amount or amounts as will compensate such Lender or Issuing Bank, as applicable, for such additional costs incurred or reduction suffered.

(b) If any Lender or Issuing Bank determines that any Change in Law regarding capital or liquidity requirements has or would have the effect of reducing the rate of return on such Lender's or Issuing Bank's capital or on the capital of such Lender's or Issuing Bank's holding company, if any, as a consequence of this Agreement or the Loans made by, or participations in Letters of Credit or Swingline Loans held by, such Lender, or the Letters of Credit issued by such Issuing Bank, to a level below that which such Lender or such Issuing Bank or such Lender's or such Issuing Bank's holding company could have achieved but for such Change in Law (taking into consideration such Lender's or such Issuing Bank's policies and the policies of such Lender's or such Issuing Bank's holding company with respect to capital adequacy and liquidity), then from time to time the Borrower shall pay to such Lender or such Issuing Bank, as applicable, such additional amount or amounts as will compensate such Lender or such Issuing Bank or such Lender's or such Issuing Bank's holding company for any such reduction suffered.

(c) A certificate of a Lender or an Issuing Bank setting forth the amount or amounts necessary to compensate such Lender or Issuing Bank or its holding company, as applicable, as specified in clause (a) or (b) of this Section shall be delivered to the Borrower and shall be conclusive absent manifest error; provided, that any such certificate claiming amounts described in clause (x) or (y) of the definition of "Change in Law" shall, in addition, state the basis upon which such amount has been calculated and certify that such Lender's or Issuing Bank's demand for payment of such costs hereunder, and such method of allocation, is not inconsistent with its treatment of other borrowers which, as a credit matter, are similarly situated to the Borrower and which are subject to similar provisions. The Borrower shall pay such Lender or Issuing Bank, as applicable, the amount shown as due on any such certificate within 10 days after receipt thereof.

(d) Promptly after any Lender or any Issuing Bank has determined that it will make a request for increased compensation pursuant to this Section 2.15, such Lender or Issuing Bank shall notify the Borrower thereof. Failure or delay on the part of any Lender or Issuing Bank to demand compensation pursuant to this Section 2.15 shall not constitute a waiver of such Lender's or Issuing Bank's right to demand such compensation; provided, that the Borrower shall not be required to compensate a Lender or an Issuing Bank pursuant to this Section 2.15 for any increased costs or reductions incurred more than 180 days prior to the date that such Lender or Issuing Bank, as applicable, notifies the Borrower of the Change in Law giving rise to such increased costs or reductions and of such Lender's or Issuing Bank's intention to claim compensation therefor; provided, further, that, if the Change in Law giving rise to such increased costs or reductions is retroactive, then the 180 day period referred to above shall be extended to include the period of retroactive effect thereof.

Section 2.16 Break Funding Payments. In the event of (a) the payment of any principal of any Eurocurrency Loan other than on the last day of an Interest Period applicable thereto (including as a result of an Event of Default), (b) the conversion of any Eurocurrency Loan other than on the last day of the Interest Period applicable thereto, (c) the failure to borrow, convert, continue or prepay any Eurocurrency Loan on the date specified in any notice delivered pursuant hereto or (d) the assignment of any Eurocurrency Loan other than on the last day of the Interest Period applicable thereto as a result of a request by the Borrower pursuant to Section 2.19, then, in any such event, the Borrower shall compensate each Lender for the loss, cost and expense attributable to such event. In the case of a Eurocurrency Loan, such loss, cost or expense to any Lender shall be deemed to be the amount determined by such Lender (it being understood that the deemed amount shall not exceed the actual amount) to be the excess, if any, of (i) the amount of interest that would have accrued on the principal amount of such Loan had such event not occurred, at the Adjusted LIBOR Rate that would have been applicable to such Loan, for the period from the date of such event to the last day of the then current Interest Period therefor (or, in the case of a failure to borrow, convert or continue a Eurocurrency Loan, for the period that would have been the Interest Period for such Loan), over (ii) the amount of interest that would accrue on such principal amount for such period at the interest rate which such Lender would bid were it to bid, at the commencement of such period, for deposits in Dollars of a comparable amount and period from other banks in the Eurocurrency market. A certificate of any Lender setting forth any amount or amounts that such Lender is entitled to receive pursuant to this Section 2.16 shall be delivered to the Borrower and shall be conclusive absent manifest error. The Borrower shall pay such Lender the amount shown as due on any such certificate within 10 days after receipt thereof.

Section 2.17 Taxes. (a) Any and all payments made by or on behalf of a Loan Party under this Agreement or any other Loan Document shall be made free and clear of, and without deduction or withholding for or on account of, any Taxes; provided that if a Loan Party, the Administrative Agent or any other applicable withholding agent shall be required by applicable Requirement of Law to deduct or withhold any Taxes from such payments, then (i) the applicable withholding agent shall make such deductions or withholdings as are



reasonably determined by the applicable withholding agent to be required by any applicable Requirement of Law, (ii) the applicable withholding agent shall timely pay the full amount deducted or withheld to the relevant Governmental Authority within the time allowed and in accordance with applicable Requirement of Law, and (iii) to the extent withholding or deduction is required to be made on account of Indemnified Taxes or Other Taxes, the sum payable by the Loan Party shall be increased as necessary so that after all required deductions and withholdings have been made (including deductions or withholdings applicable to additional sums payable under this Section 2.17) the Administrative Agent or any Lender, as applicable, receives an amount equal to the sum it would have received had no such deductions or withholdings been made. Whenever any Indemnified Taxes or Other Taxes are payable by a Loan Party, as promptly as possible thereafter, such Loan Party shall send to the Administrative Agent for its own account or for the account of a Lender, as the case may be, a certified copy of an official receipt (or other evidence acceptable to the Administrative Agent or such Lender, acting reasonably) received by the Loan Party showing payment thereof. Without duplication, after any payment of Taxes by any Loan Party or the Administrative Agent to a Governmental Authority as provided in this Section 2.17, the Borrower shall deliver to the Administrative Agent or the Administrative Agent shall deliver to the Borrower, as the case may be, a copy of a receipt issued by such Governmental Authority evidencing such payment, a copy of any return required by applicable Requirements of Law to report such payment or other evidence of such payment reasonably satisfactory to the Borrower or the Administrative Agent, as the case may be.

(b) The Borrower shall timely pay any Other Taxes.

(c) The Borrower shall indemnify and hold harmless the Administrative Agent and each Lender within 15 Business Days after written demand therefor, for the full amount of any Indemnified Taxes or Other Taxes imposed on the Administrative Agent or such Lender, as the case may be (including Indemnified Taxes or Other Taxes imposed or asserted on or attributable to amounts payable under this Section 2.17), and any reasonable expenses arising therefrom or with respect thereto, whether or not such Indemnified Taxes or Other Taxes were correctly or legally imposed or asserted by the relevant Governmental Authority. A certificate setting forth in reasonable detail the basis and calculation of the amount of such payment or liability delivered to the Borrower by a Lender or the Administrative Agent (as applicable) on its own behalf or on behalf of a Lender shall be conclusive absent manifest error.

(d) Each Lender shall deliver to the Borrower and the Administrative Agent, at such time or times reasonably requested by the Borrower or the Administrative Agent, such properly completed and executed documentation prescribed by applicable law and such other reasonably requested information as will permit the Borrower or the Administrative Agent, as the case may be, to determine (A) whether or not any payments made hereunder or under any other Loan Document are subject to withholding of Taxes, (B) if applicable, the required rate of withholding or deduction, and (C) such Lender's entitlement to any available exemption from, or reduction of, any such withholding of Taxes in respect of any payments to be made to such Lender by any Loan Party pursuant to any Loan Document or otherwise to establish such Lender's status for withholding tax purposes in the applicable jurisdiction. In addition, any Lender, if requested by the Borrower or the Administrative Agent, shall deliver such other documentation prescribed by applicable law or reasonably requested by the Borrower or the Administrative Agent as will enable the Borrower or the Administrative Agent to determine whether or not such Lender is subject to backup withholding or information reporting requirements.

(e) Without limiting the generality of Section 2.17(d), each Foreign Lender with respect to any Loan made to the Borrower shall, to the extent it is legally eligible to do so:

(i) deliver to the Borrower and the Administrative Agent, prior to the date on which the first payment to the Foreign Lender is due hereunder, two copies of (A) in the case of a Foreign Lender claiming exemption from U.S. federal withholding tax under Section 871(h) or 881(c) of the Code with respect to payments of “portfolio interest”, United States Internal Revenue Service Form W-8BEN or Form W-8BEN-E (or any applicable successor form) (together with a certificate (substantially in the form of Exhibit J hereto), such certificate, the “Non-Bank Tax Certificate”) certifying that such Foreign Lender is not a bank for purposes of Section 881(c) of the Code, is not a “10-percent shareholder” (within the meaning of Section 871(h)(3)(B) of the Code) of the Borrower and is not a CFC related to the Borrower (within the meaning of Section 864(d)(4) of the Code), and that the interest payments in question are not effectively connected with the conduct by such Lender of a trade or business within the United States of America), (B) Internal Revenue Service Form W-8BEN, Form W-8BEN-E, Form W-8EXP or Form W-8ECI (or any applicable successor form), in each case properly completed and duly executed by such Foreign Lender claiming complete exemption from, or reduced rate of, U.S. federal withholding tax on payments by the Borrower under this Agreement, (C) Internal Revenue Service Form W-8IMY (or any applicable successor form) and all necessary attachments (including the forms described in clauses (A) and (B) above, provided that if the Foreign Lender is a partnership, and one or more of the partners is claiming portfolio interest treatment, the Non-Bank Tax Certificate may be provided by such Foreign Lender on behalf of such partners) or (D) any other form prescribed by applicable law as a basis for claiming exemption from or a reduction in United States federal withholding tax duly completed together with such supplementary documentation as may be prescribed by applicable law to permit the Borrower or the Administrative Agent to determine the withholding or deduction required to be made; and

(ii) deliver to the Borrower and the Administrative Agent two further copies of any such form or certification (or any applicable successor form) on or before the date that any such form or certification expires or becomes obsolete or invalid, after the occurrence of any event requiring a change in the most recent form previously delivered by it to the Borrower and the Administrative Agent, and from time to time thereafter if reasonably requested by the Borrower or the Administrative Agent.

Any Foreign Lender that becomes legally ineligible to update any form or certification previously delivered shall promptly notify the Borrower and the Administrative Agent in writing of such Foreign Lender’s inability to do so.

Each person that shall become a Participant pursuant to Section 9.04 or a Lender pursuant to Section 9.04 shall, upon the effectiveness of the related transfer, be required to provide all the forms and statements required pursuant to this Section 2.17(e); provided that a Participant shall furnish all such required forms and statements to the person from which the related participation shall have been purchased.

In addition, each Agent shall deliver to the Borrower (x)(I) prior to the date on which the first payment by the Borrower is due hereunder or (II) prior to the first date on or after the date on which such Agent becomes a successor Administrative Agent pursuant to Section 8.09 on which payment by the Borrower is due hereunder, as applicable, two copies of a properly completed and executed IRS Form W-9 certifying its exemption from U.S. federal backup withholding or such other properly completed and executed documentation prescribed by applicable law certifying its entitlement to an available exemption from applicable U.S. federal withholding taxes in respect of any payments to be made to such Agent by any Loan Party pursuant to any Loan Document including, as applicable, an IRS Form W-8IMY certifying that the Agent is a U.S. branch and intends to be treated as a U.S. person for purposes of withholding under Chapter 3 of the Code pursuant to Section 1.1441-1(b)(2)(iv) of the Treasury Regulations, and (y) on or before the date on which any such previously delivered documentation expires or becomes obsolete or invalid, after the occurrence of any event requiring a change in the most recent documentation previously delivered by it to the Borrower and from time to time if reasonably requested by the Borrower, two further copies of such documentation. Notwithstanding anything to the contrary, an Agent is not required to provide any documentation that it is not legally eligible to provide as a result of any change in Requirements of Law occurring after the date hereof.

(f) If any Lender or the Administrative Agent, as applicable, determines, in its sole discretion, that it has received a refund of an Indemnified Tax or Other Tax for which a payment has been made by a Loan Party pursuant to this Agreement or any other Loan Document, which refund in the good faith judgment of such Lender or the Administrative Agent, as the case may be, is attributable to such payment made by such Loan Party, then the Lender or the Administrative Agent, as the case may be, shall reimburse the Loan Party for such amount (net of all reasonable out-of-pocket expenses of such Lender or the Administrative Agent, as the case may be, and without interest other than any interest received thereon from the relevant Governmental Authority with respect to such refund) as the Lender or Administrative Agent, as the case may be, determines in its sole discretion to be the proportion of the refund as will leave it, after such reimbursement, in no better or worse position (taking into account expenses or any Taxes imposed on the refund) than it would have been in if the Indemnified Tax or Other Tax giving rise to such refund had not been imposed in the first instance; provided, that the Loan Party, upon the request of the Lender or the Administrative Agent agrees to repay the amount paid over to the Loan Party (plus any penalties, interest or other charges imposed by the relevant Governmental Authority) to the Lender or the Administrative Agent in the event the Lender or the Administrative Agent is required to repay such refund to such Governmental Authority. In such event, such Lender or the Administrative Agent, as the case may be, shall, at the Borrower's request, provide the Borrower with a copy of any notice of assessment or other evidence of the requirement to repay such refund received from the relevant Governmental Authority (provided that such Lender or the Administrative Agent may delete any information therein that it deems confidential). A Lender or the Administrative Agent shall claim any refund that it determines is available to it, unless it concludes in its sole discretion that it would be

adversely affected by making such a claim. No Lender nor the Administrative Agent shall be obliged to make available its tax returns (or any other information relating to its taxes that it deems confidential) to any Loan Party in connection with this clause (f) or any other provision of this Section 2.17.

(g) If the Borrower determines that a reasonable basis exists for contesting an Indemnified Tax or Other Tax for which a Loan Party has paid additional amounts or indemnification payments, each affected Lender or Agent, as the case may be, shall use reasonable efforts to cooperate with the Borrower as the Borrower may reasonably request in challenging such Tax. The Borrower shall indemnify and hold each Lender and Agent harmless against any out-of-pocket expenses incurred by such person in connection with any request made by the Borrower pursuant to this Section 2.17(g). Nothing in this Section 2.17(g) shall obligate any Lender or Agent to take any action that such person, in its sole judgment, determines may result in a material detriment to such person.

(h) Each U.S. Lender shall deliver to the Borrower and the Administrative Agent two Internal Revenue Service Forms W-9 (or substitute or successor form), properly completed and duly executed, certifying that such U.S. Lender is exempt from United States federal backup withholding (i) on or prior to the Closing Date (or on or prior to the date it becomes a party to this Agreement), (ii) on or before the date that such form expires or becomes obsolete or invalid, (iii) after the occurrence of a change in the U.S. Lender's circumstances requiring a change in the most recent form previously delivered by it to the Borrower and the Administrative Agent, and (iv) from time to time thereafter if reasonably requested by the Borrower or the Administrative Agent.

(i) If a payment made to any Lender or any Agent under this Agreement or any other Loan Document would be subject to U.S. federal withholding tax imposed by FATCA if such Lender or such Agent were to fail to comply with the applicable reporting requirements of FATCA (including those contained in Section 1471(b) or 1472(b) of the Code, as applicable), such Lender or such Agent shall deliver to the Borrower and the Administrative Agent at the time or times prescribed by law and at such time or times reasonably requested by the Borrower or the Administrative Agent such documentation prescribed by applicable law (including as prescribed by Section 1471(b)(3)(C)(i) of the Code) and such additional documentation reasonably requested by the Borrower or the Administrative Agent as may be necessary for the Borrower and the Administrative Agent to comply with their obligations under FATCA, to determine whether such Lender has or has not complied with such Lender's obligations under FATCA or to determine the amount, if any, to deduct and withhold from such payment. Solely for purposes of this Section 2.17(i), "FATCA" shall include any amendments made to FATCA after the date of this Agreement.

(j) The agreements in this Section 2.17 shall survive the termination of this Agreement and the payment of the Loans and all other amounts payable under any Loan Document.

For purposes of this Section 2.17, the term "Lender" includes any Issuing Bank and the term "applicable Requirement of Law" includes FATCA.

Section 2.18 Payments Generally; Pro Rata Treatment; Sharing of Set-offs.

(a) Unless otherwise specified, the Borrower shall make each payment required to be made by it hereunder (whether of principal, interest, fees or reimbursement of L/C Disbursements, or of amounts payable under Section 2.15, 2.16 or 2.17, or otherwise) prior to 2:00 p.m., Local Time, on the date when due, in immediately available funds, without condition or deduction for any defense, recoupment, set off or counterclaim. Any amounts received after such time on any date may, in the discretion of the Administrative Agent, be deemed to have been received on the next succeeding Business Day for purposes of calculating interest thereon. All such payments shall be made to the Administrative Agent to the applicable account designated to the Borrower by the Administrative Agent, except payments to be made directly to the applicable Issuing Bank or the Swingline Lender as expressly provided herein and except that payments pursuant to Sections 2.15, 2.16, 2.17 and 9.05 shall be made directly to the persons entitled thereto. The Administrative Agent shall distribute any such payments received by it for the account of any other person to the appropriate recipient promptly following receipt thereof. Except as otherwise expressly provided herein, if any payment hereunder shall be due on a day that is not a Business Day, the date for payment shall be extended to the next succeeding Business Day, and, in the case of any payment accruing interest, interest thereon shall be payable for the period of such extension. All payments made under the Loan Documents shall be made in Dollars. Any payment required to be made by the Administrative Agent hereunder shall be deemed to have been made by the time required if the Administrative Agent shall, at or before such time, have taken the necessary steps to make such payment in accordance with the regulations or operating procedures of the clearing or settlement system used by the Administrative Agent to make such payment.

(b) If at any time insufficient funds are received by and available to the Administrative Agent from any Loan Party (or proceeds from any Collateral) following an acceleration of the Obligations under this Agreement or any Event of Default under Section 7.01(h) or (i), to pay fully all amounts of principal, unreimbursed L/C Disbursements, interest and fees and other Obligations then due from the Borrower hereunder, such funds shall be applied, subject to any applicable intercreditor agreement: first, ratably, to pay any fees, indemnities, or expense reimbursements then due to the Administrative Agent, the Collateral Agent or any Issuing Bank from the Borrower (other than in connection with obligations in respect of Secured Cash Management Agreements or Secured Hedge Agreements); second, ratably, to pay interest due and payable in respect of any unreimbursed L/C Disbursements, Protective Advances and Overadvances; third, ratably to pay principal of unreimbursed L/C Disbursements, Protective Advances and Overadvances; fourth, ratably, to pay any fees, indemnities or expense reimbursements then due to the Lenders from the Borrower (other than in connection with obligations in respect of Secured Cash Management Agreements or Secured Hedge Agreements); fifth, ratably, to pay interest due and payable in respect of any Revolving Loans; sixth, ratably, to pay principal of Swingline Loans and Revolving Loans (other than Protective Advances and Overadvances) then due from the Borrower hereunder and any Pari Passu Secured Hedge Obligations and to Cash Collateralize Revolving L/C Exposure in accordance with the procedures set forth in Section 2.05(j); seventh, ratably, to the payment of any obligations in respect of Secured Cash Management Agreements and any other Secured Hedge Agreements that do not constitute Pari Passu Secured Hedge Obligations; eighth, ratably, to the payment of any other Secured Obligations due to the Agents or any Lender by the Borrower; and ninth, to the Borrower or as the Borrower shall direct.

(c) If any Lender shall, by exercising any right of set-off or counterclaim or otherwise, obtain payment in respect of any principal of, or interest on, any of its Revolving Loans or participations in L/C Disbursements or Swingline Loans resulting in such Lender receiving payment of a greater proportion of the aggregate amount of its Revolving Loans and participations in L/C Disbursements and Swingline Loans and accrued interest thereon than the proportion received by any other Lender entitled to receive the same proportion of such payment, then the Lender receiving such greater proportion shall purchase participations in the Revolving Loans and participations in L/C Disbursements and Swingline Loans of such other Lenders to the extent necessary so that the benefit of all such payments shall be shared by all such Lenders ratably in accordance with the principal amount of each such Lender's respective Revolving Loans and participations in L/C Disbursements and Swingline Loans and accrued interest thereon vis-à-vis the aggregate principal amount of all such Lenders' Revolving Loans and participations in L/C Disbursements and Swingline Loans and the aggregate accrued interest thereon; provided, that (i) if any such participations are purchased and all or any portion of the payment giving rise thereto is recovered, such participations shall be rescinded and the purchase price restored to the extent of such recovery, without interest, and (ii) the provisions of this clause (c) shall not be construed to apply to any payment made by the Borrower pursuant to and in accordance with the express terms of this Agreement or any payment obtained by a Lender as consideration for the assignment of or sale of a participation in any of its Loans or participations in L/C Disbursements to any assignee or participant. The Borrower consents to the foregoing and agrees, to the extent it may effectively do so under applicable law, that any Lender acquiring a participation pursuant to the foregoing arrangements may exercise against the Borrower rights of set-off and counterclaim with respect to such participation as fully as if such Lender were a direct creditor of the Borrower in the amount of such participation.

(d) Unless the Administrative Agent shall have received notice from the Borrower prior to the date on which any payment is due to the Administrative Agent for the account of the Lenders or the applicable Issuing Bank hereunder that the Borrower will not make such payment, the Administrative Agent may assume that the Borrower has made such payment on such date in accordance herewith and may, in reliance upon such assumption, distribute to the Lenders or the applicable Issuing Bank, as applicable, the amount due. In such event, if the Borrower has not in fact made such payment, then each of the Lenders or the applicable Issuing Bank, as applicable, severally agrees to repay to the Administrative Agent forthwith on demand the amount so distributed to such Lender or Issuing Bank with interest thereon, for each day from and including the date such amount is distributed to it to but excluding the date of payment to the Administrative Agent, at the greater of the Federal Funds Effective Rate and a rate determined by the Administrative Agent in accordance with banking industry rules on interbank compensation.

(e) If any Lender shall fail to make any payment required to be made by it pursuant to Section 2.04(c), 2.05(d) or (e), 2.06(b) or (c), 2.18(d) or 2.21, then the Administrative Agent may, in its discretion (notwithstanding any contrary provision hereof), apply any amounts thereafter received by the Administrative Agent for the account of such Lender to satisfy such Lender's obligations under such Sections until all such unsatisfied obligations are fully paid.

Section 2.19 Mitigation Obligations; Replacement of Lenders. (a) If any Lender requests compensation under Section 2.15, or if the Borrower is required to pay any additional amount to any Lender or any Governmental Authority for the account of any Lender pursuant to Section 2.17, then such Lender shall use reasonable efforts to designate a different Lending Office for funding or booking its Loans hereunder or to assign its rights and obligations hereunder to another of its offices, branches or Affiliates, if, in the reasonable judgment of such Lender, such designation or assignment (i) would eliminate or reduce amounts payable pursuant to Section 2.15 or 2.17, as applicable, in the future and (ii) would not subject such Lender to any material unreimbursed cost or expense and would not otherwise be disadvantageous to such Lender in any material respect. The Borrower hereby agrees to pay all reasonable costs and expenses incurred by any Lender in connection with any such designation or assignment.

(b) If any Lender requests compensation under Section 2.15, or if the Borrower is required to pay any additional amount to any Lender or any Governmental Authority for the account of any Lender pursuant to Section 2.17, or if any Lender is a Defaulting Lender, then the Borrower may, at its sole expense and effort, upon notice to such Lender and the Administrative Agent, require any such Lender to assign and delegate, without recourse (in accordance with and subject to the restrictions contained in Section 9.04), all its interests, rights and obligations under this Agreement to an assignee that shall assume such obligations (which assignee may be another Lender, if a Lender accepts such assignment); provided, that (i) the Borrower shall have received the prior written consent of the Administrative Agent, the Swingline Lender and the Issuing Bank, which consent, in each case, shall not unreasonably be withheld, (ii) such Lender shall have received payment of an amount equal to the outstanding principal of its Loans and participations in L/C Disbursements and Swingline Loans, accrued interest thereon, accrued fees and all other amounts payable to it hereunder, from the assignee (to the extent of such outstanding principal and accrued interest and fees) or the Borrower (in the case of all other amounts) and (iii) in the case of any such assignment resulting from a claim for compensation under Section 2.15 or payments required to be made pursuant to Section 2.17, such assignment will result in a reduction in such compensation or payments. Nothing in this Section 2.19 shall be deemed to prejudice any rights that the Borrower may have against any Lender that is a Defaulting Lender. No action by or consent of the removed Lender shall be necessary in connection with such assignment, which shall be immediately and automatically effective upon payment of such purchase price. In connection with any such assignment the Borrower, Administrative Agent, such removed Lender and the replacement Lender shall otherwise comply with Section 9.04; provided, that if such removed Lender does not comply with Section 9.04 within one Business Day after the Borrower's request, compliance with Section 9.04 shall not be required to effect such assignment.

(c) If any Lender (such Lender, a "Non-Consenting Lender") has failed to consent to a proposed amendment, waiver, discharge or termination which pursuant to the terms of Section 9.08 requires the consent of all of the Lenders affected and with respect to which the Required Lenders (or, if such amendment waiver by its terms requires the consent of

the Super Majority Lenders, the Super Majority Lenders) shall have granted their consent, then the Borrower shall have the right (unless such Non-Consenting Lender grants such consent) at its sole expense (including with respect to the processing and recordation fee referred to in Section 9.04(b)(ii)(B)) to replace such Non-Consenting Lender by requiring such Non-Consenting Lender to (and any such Non-Consenting Lender agrees that it shall, upon the Borrower's request) assign its Loans and its Commitments (or, at the Borrower's option, the Loans and Commitments under the Facility that is the subject of the proposed amendment, waiver, discharge or termination) hereunder to one or more assignees reasonably acceptable to the Administrative Agent, the Swingline Lender and the Issuing Bank (unless such assignee is a Lender, an Affiliate of a Lender or an Approved Fund); provided, that: (a) all Loan Obligations of the Borrower owing to such Non-Consenting Lender (including accrued Fees and any amounts due under Section 2.15, 2.16 or 2.17) being replaced shall be paid in full to such Non-Consenting Lender concurrently with such assignment, (b) the replacement Lender shall purchase the foregoing by paying to such Non-Consenting Lender a price equal to the principal amount thereof plus accrued and unpaid interest thereon and (c) the replacement Lender shall grant its consent with respect to the applicable proposed amendment, waiver, discharge or termination. No action by or consent of the Non-Consenting Lender shall be necessary in connection with such assignment, which shall be immediately and automatically effective upon payment of such purchase price. In connection with any such assignment the Borrower, Administrative Agent, such Non-Consenting Lender and the replacement Lender shall otherwise comply with Section 9.04; provided, that if such Non-Consenting Lender does not comply with Section 9.04 one Business Day after the Borrower's request, compliance with Section 9.04 shall not be required to effect such assignment.

Section 2.20 Illegality. If any Lender reasonably determines that any Change in Law has made it unlawful, or that any Governmental Authority has asserted after the Closing Date that it is unlawful, for any Lender or its applicable lending office to make or maintain any Eurocurrency Loans, then, on notice thereof by such Lender to the Borrower through the Administrative Agent, any obligations of such Lender to make or continue Eurocurrency Loans or to convert ABR Borrowings to Eurocurrency Borrowings shall be suspended until such Lender notifies the Administrative Agent and the Borrower that the circumstances giving rise to such determination no longer exist. Upon receipt of such notice, the Borrower shall upon demand from such Lender (with a copy to the Administrative Agent), either convert all Eurocurrency Borrowings of such Lender to ABR Borrowings, either on the last day of the Interest Period therefor, if such Lender may lawfully continue to maintain such Eurocurrency Borrowings to such day, or immediately, if such Lender may not lawfully continue to maintain such Loans. Upon any such prepayment or conversion, the Borrower shall also pay accrued interest on the amount so prepaid or converted.

Section 2.21 Incremental Commitments. (a) The Borrower may, after the Closing Date, by written notice to the Administrative Agent from time to time, request Incremental Revolving Commitments in an amount not to exceed the Incremental Amount at the time such Incremental Revolving Commitments are established from one or more Incremental Revolving Lenders (which may include any existing Lender) willing to provide such Incremental Revolving Commitments in their own discretion; provided, that each Incremental Revolving Lender shall be subject to the approval of the Administrative Agent (which approval shall not be



unreasonably withheld) unless such Incremental Revolving Lender is a Lender, an Affiliate of a Lender or an Approved Fund. Such notice shall set forth (i) the amount of the Incremental Revolving Commitments being requested (which shall be in minimum increments of \$1,000,000 and a minimum amount of \$5,000,000 or equal to the remaining Incremental Amount) and (ii) the date on which such Incremental Revolving Commitments are requested to become effective (the "Increased Amount Date"). All Incremental Revolving Commitments shall be commitments to make additional Revolving Loans (such additional Revolving Loans, the "Incremental Revolving Facility Loans") on the same terms as (and having the same guarantees as and ranking pari passu in right of payment and of security with), and forming a single Class with, the Revolving Loans made pursuant to the Commitments in effect on the Closing Date (the "Initial Revolving Facility Loans") or a then existing Class of Extended Revolving Commitments.

(b) The Borrower and each Incremental Revolving Lender shall execute and deliver to the Administrative Agent an Incremental Assumption Agreement and such other documentation as the Administrative Agent shall reasonably specify to evidence the Incremental Revolving Commitment of such Incremental Revolving Lender. Each party hereto hereby agrees that, upon the effectiveness of any Incremental Assumption Agreement, this Agreement shall be amended to the extent (but only to the extent) necessary to reflect the existence of the Incremental Revolving Commitments evidenced thereby as provided for in Section 9.08(e). Any amendment to this Agreement or any other Loan Document that is necessary to effect the provisions of this Section 2.21 and any such collateral and other documentation shall be deemed "Loan Documents" hereunder and may be memorialized in writing by the Administrative Agent with the Borrower's consent (not to be unreasonably withheld) and furnished to the other parties hereto.

(c) Notwithstanding the foregoing, no Incremental Commitment shall become effective under this Section 2.21 unless (i) on the date of such effectiveness, to the extent required by the relevant Incremental Assumption Agreement, the conditions set forth in clauses (b) and (c) of Section 4.01 shall be satisfied and the Administrative Agent shall have received a certificate to that effect dated such date and executed by a Responsible Officer of the Borrower and (ii) the Administrative Agent shall have received customary legal opinions, board resolutions and other customary closing certificates and documentation as required by the relevant Incremental Assumption Agreement and, to the extent required by the Administrative Agent, consistent with those delivered on the Closing Date and such additional customary documents and filings (including amendments to the Mortgages and other Security Documents and title endorsement bringdowns) as the Administrative Agent may reasonably request to assure that the Loans in respect of Incremental Commitments are secured by the Collateral ratably with one or more Classes of the then existing Loans.

(d) Each of the parties hereto hereby agrees that the Administrative Agent may take any and all action as may be reasonably necessary to ensure that all Loans in respect of Incremental Commitments, when originally made, are included in each Borrowing of outstanding Revolving Facility Loans on a pro rata basis. The Borrower agrees that Section 2.16 shall apply to any conversion of Eurocurrency Loans to ABR Loans reasonably required by the Administrative Agent to effect the foregoing.

(e) Notwithstanding anything to the contrary in Section 2.18(e) (which provisions shall not be applicable to clauses (e) through (i) of this Section 2.21), pursuant to one or more offers made from time to time by the Borrower to all Lenders of any Class of Revolving Commitments, on a pro rata basis (based on the aggregate outstanding Revolving Commitments under such Facility, as applicable) and on the same terms (“Pro Rata Extension Offers”), the Borrower is hereby permitted to consummate transactions with individual Lenders from time to time to extend the maturity date of such Lender’s Commitments of such Class and to otherwise modify the terms of such Lender’s Commitments of such Class pursuant to the terms of the relevant Pro Rata Extension Offer (including without limitation increasing the interest rate or fees payable in respect of such Lender’s Commitments). For the avoidance of doubt, the reference to “on the same terms” in the preceding sentence shall mean, in the case of an offer to the Lenders under any Class of Revolving Commitments, that all of the Revolving Commitments of such Class are offered to be extended for the same amount of time and that the interest rate changes and fees payable with respect to such extension are the same. Any such extension (an “Extension”) agreed to between the Borrower and any such Lender (an “Extending Lender”) will be established under this Agreement by implementing an Incremental Commitment for such Lender (such extended Revolving Commitment, an “Extended Revolving Commitment”, and the Revolving Loans made thereunder “Extended Revolving Loans”). Each Pro Rata Extension Offer shall specify the date on which the Borrower proposes that the Extended Revolving Commitment shall be extended, which shall be a date not earlier than five Business Days after the date on which notice is delivered to the Administrative Agent (or such shorter period agreed to by the Administrative Agent in its reasonable discretion).

(f) The Borrower and each Extending Lender shall execute and deliver to the Administrative Agent an Incremental Assumption Agreement and such other documentation as the Administrative Agent shall reasonably specify to evidence the Extended Revolving Commitments of such Extending Lender. Each Incremental Assumption Agreement shall specify the terms of the applicable Extended Revolving Commitments; provided, that (i) except as to fees (which fees shall be determined by the Borrower and set forth in the Pro Rata Extension Offer), any Extended Revolving Commitment shall have (x) the same terms as an existing Class of Revolving Commitments or (y) have such other terms as shall be reasonably satisfactory to the Administrative Agent and (ii) any Extended Revolving Commitments may participate on a pro rata basis or a less than pro rata basis (but not greater than a pro rata basis) in any voluntary or mandatory repayments or prepayments hereunder. Upon the effectiveness of any Incremental Assumption Agreement, this Agreement shall be amended to the extent (but only to the extent) necessary to reflect the existence and terms of the Extended Revolving Commitments evidenced thereby as provided for in Section 9.08(e). Any such deemed amendment may be memorialized in writing by the Administrative Agent with the Borrower’s consent (not to be unreasonably withheld) and furnished to the other parties hereto. If provided in any Incremental Assumption Agreement with respect to any Extended Revolving Commitments, and with the consent of each Swingline Lender and Issuing Bank, participations in Swingline Loans and Letters of Credit shall be reallocated to lenders holding such Extended Revolving Commitments in the manner specified in such Incremental Assignment Agreement, including upon effectiveness of such Extended Revolving Commitment or upon or prior to the maturity date for any Class of Revolving Commitment.

(g) Upon the effectiveness of any such Extension, the applicable Extending Lender's Revolving Commitment will be automatically designated an Extended Revolving Commitment. For purposes of this Agreement and the other Loan Documents, such Extending Lender will be deemed to have an Incremental Commitment having the terms of such Extended Revolving Commitment.

(h) Notwithstanding anything to the contrary set forth in this Agreement or any other Loan Document (including without limitation this Section 2.21), (i) the aggregate amount of Extended Revolving Commitments will not be included in the calculation of the Incremental Amount, (ii) no Extended Revolving Commitment is required to be in any minimum amount or any minimum increment, (iii) any Extending Lender may extend all or any portion of its Revolving Commitment pursuant to one or more Pro Rata Extension Offers (subject to applicable proration in the case of over participation) (including the extension of any Extended Revolving Commitment), (iv) there shall be no condition to any Extension of any Commitment at any time or from time to time other than notice to the Administrative Agent of such Extension and the terms of the Extended Revolving Commitment implemented thereby pursuant to the applicable Incremental Assumption Agreement, (v) all Extended Revolving Commitments and all obligations in respect thereof shall be Obligations of the relevant Loan Parties under this Agreement and the other Loan Documents that are secured by the Collateral on a pari passu basis with all other Obligations of the relevant Loan Parties under this Agreement and the other Loan Documents and (vi) no Issuing Bank or Swingline Lender shall be obligated to provide Swingline Loans or issue Letters of Credit under such Extended Revolving Commitments unless it shall have consented thereto.

(i) Each Extension shall be consummated pursuant to procedures set forth in the associated Pro Rata Extension Offer; provided, that the Borrower shall cooperate with the Administrative Agent prior to making any Pro Rata Extension Offer to establish reasonable procedures with respect to mechanical provisions relating to such Extension, including, without limitation, timing, rounding and other adjustments.

#### Section 2.22 Defaulting Lender.

(a) Defaulting Lender Adjustments. Notwithstanding anything to the contrary contained in this Agreement, if any Lender becomes a Defaulting Lender, then, until such time as such Lender is no longer a Defaulting Lender, to the extent permitted by applicable law:

(i) *Waivers and Amendments*. Such Defaulting Lender's right to approve or disapprove any amendment, waiver or consent with respect to this Agreement shall be restricted as set forth in the definition of Required Lenders or Super Majority Lenders, as applicable.

(ii) *Defaulting Lender Waterfall*. Any payment of principal, interest, fees or other amounts received by the Administrative Agent for the account of such Defaulting Lender (whether voluntary or mandatory, at maturity, following an Event of Default or otherwise) or received by the Administrative Agent from a Defaulting Lender pursuant to Section 9.06 shall be applied at such time or times as may be determined by the Administrative

Agent as follows: first, to the payment of any amounts owing by such Defaulting Lender to the Administrative Agent hereunder, second, to the payment on a pro rata basis of any amounts owing by such Defaulting Lender to any Issuing Bank or the Swingline Lender hereunder, third, to Cash Collateralize the Issuing Banks' Fronting Exposure with respect to such Defaulting Lender in accordance with Section 2.05(j), fourth, as the Borrower may request (so long as no Default or Event of Default exists), to the funding of any Loan in respect of which such Defaulting Lender has failed to fund its portion thereof as required by this Agreement, as determined by the Administrative Agent, fifth, if so determined by the Administrative Agent and the Borrower, to be held in a deposit account and released pro rata in order to (x) satisfy such Defaulting Lender's potential future funding obligations with respect to Loans under this Agreement, and (y) Cash Collateralize the Issuing Banks' future Fronting Exposure with respect to such Defaulting Lender with respect to future Letters of Credit issued under this Agreement, in accordance with Section 2.05(j), sixth, to the payment of any amounts owing to the Lenders, the Issuing Banks or the Swingline Lender as a result of any judgment of a court of competent jurisdiction obtained by any Lender, the Issuing Banks or the Swingline Lender against such Defaulting Lender as a result of such Defaulting Lender's breach of its obligations under this Agreement, seventh, so long as no Default or Event of Default exists, to the payment of any amounts owing to the Borrower as a result of any judgment of a court of competent jurisdiction obtained by the Borrower against such Defaulting Lender as a result of such Defaulting Lender's breach of its obligations under this Agreement, and eighth, to such Defaulting Lender or as otherwise directed by a court of competent jurisdiction. Any payments, prepayments or other amounts paid or payable to a Defaulting Lender that are applied (or held) to pay amounts owed by a Defaulting Lender or to post Cash Collateral pursuant to this Section 2.22 shall be deemed paid to and redirected by such Defaulting Lender, and each Lender irrevocably consents hereto.

(iii) *Certain Fees.* (A) No Defaulting Lender shall be entitled to receive any Commitment Fee for any period during which that Lender is a Defaulting Lender.

(B) Each Defaulting Lender shall be entitled to receive L/C Participation Fees for any period during which that Lender is a Defaulting Lender only to the extent allocable to its pro rata share of the stated amount of Letters of Credit for which it has provided Cash Collateral.

(C) With respect to any Commitment Fee or L/C Participation Fee not required to be paid to any Defaulting Lender pursuant to clause (A) or (B) above, the Borrower shall (x) pay to each Non-Defaulting Lender that portion of any such fee otherwise payable to such Defaulting Lender with respect to such Defaulting Lender's participation in Letters of Credit or Swingline Loans that has been reallocated to such Non-Defaulting Lender pursuant to clause (iv) below, (y) pay to each Issuing Bank and the Swingline Lender, as applicable, the amount of any such fee otherwise payable to such Defaulting Lender to the extent allocable to such Issuing Bank's or the Swingline Lender's Fronting Exposure to such Defaulting Lender, and (z) not be required to pay the remaining amount of any such fee.

(iv) *Reallocation of Participations to Reduce Fronting Exposure.* All or any part of such Defaulting Lender's participation in Letters of Credit and Swingline Loans shall be reallocated among the Non-Defaulting Lenders in accordance with their respective pro rata Commitments (calculated without regard to such Defaulting Lender's Commitment) but only to the extent that (x) the conditions set forth in Section 4.01 are satisfied at the time of such reallocation (and, unless the Borrower shall have otherwise notified the Administrative Agent at such time, the Borrower shall be deemed to have represented and warranted that such conditions are satisfied at such time) and (y) such reallocation does not cause the aggregate Revolving Facility Credit Exposure of any Non-Defaulting Lender to exceed such Non-Defaulting Lender's Revolving Commitment. Subject to Section 9.22, no reallocation hereunder shall constitute a waiver or release of any claim of any party hereunder against a Defaulting Lender arising from that Lender having become a Defaulting Lender, including any claim of a Non-Defaulting Lender as a result of such Non-Defaulting Lender's increased exposure following such reallocation.

(v) *Cash Collateral, Repayment of Swingline Loans.* If the reallocation described in clause (iv) above cannot, or can only partially, be effected, the Borrower shall, without prejudice to any right or remedy available to it hereunder or under law, within one (1) Business Day following the written request of the (i) Administrative Agent or (ii) the Swingline Lender or any Issuing Bank, as applicable (with a copy to the Administrative Agent), (x) first, prepay Swingline Loans in an amount equal to the Swingline Lender's Fronting Exposure and (y) second, Cash Collateralize the Issuing Banks' Fronting Exposure in accordance with the procedures set forth in Section 2.05(j).

(b) Defaulting Lender Cure. If the Borrower, the Administrative Agent and the Swingline Lender and each Issuing Bank agree in writing that a Lender is no longer a Defaulting Lender, the Administrative Agent will so notify the parties hereto, whereupon as of the effective date specified in such notice and subject to any conditions set forth therein (which may include arrangements with respect to any Cash Collateral), that Lender will, to the extent applicable, purchase at par that portion of outstanding Revolving Loans of the other Lenders or take such actions as the Administrative Agent may determine to be necessary to cause the Loans and funded and unfunded participations in Letters of Credit and Swingline Loans to be held pro rata by the Lenders in accordance with their Revolving Commitments (without giving effect to Section 2.22(a)(iv)), whereupon such Lender will cease to be a Defaulting Lender; provided, that no adjustments will be made retroactively with respect to fees accrued or payments made by or on behalf of the Borrower while that Lender was a Defaulting Lender; provided, further, that except to the extent otherwise expressly agreed by the affected parties, no change hereunder from Defaulting Lender to Lender will constitute a waiver or release of any claim of any party hereunder arising from that Lender's having been a Defaulting Lender.

(c) New Swingline Loans / Letters of Credit. So long as any Lender is a Defaulting Lender, (i) the Swingline Lender shall not be required to fund any Swingline Loans unless it is satisfied that it will have no Fronting Exposure after giving effect to such Swingline Loan and (ii) the Issuing Banks shall not be required to issue, extend, renew or increase any Letter of Credit unless it is satisfied that it will have no Fronting Exposure after giving effect thereto.

ARTICLE III

*Representations and Warranties*

On the Effective Date (with respect to Holdings only, and only with respect to the representations and warranties of Holdings set forth in Sections 3.01(a) and (d), 3.02(a) and (b)(i)(B), 3.03, 3.11, 3.22, the final sentence of 3.25(b) and the final sentence of 3.26), on the Closing Date, and on the date of each Credit Event, the Borrower (or in the case of representations and warranties made on the Effective Date, Holdings) represents and warrants to each of the Lenders that:

Section 3.01 Organization; Powers. Except as set forth on Schedule 3.01, each of Holdings (prior to a Qualified IPO), the Borrower and each of the Material Subsidiaries (a) is a partnership, limited liability company or corporation duly organized, validly existing and in good standing (or, if applicable in a foreign jurisdiction, enjoys the equivalent status under the laws of any jurisdiction of organization outside the United States of America) under the laws of the jurisdiction of its organization, (b) has all requisite power and authority to own its property and assets and to carry on its business as now conducted, (c) is qualified to do business in each jurisdiction where such qualification is required, except where the failure so to qualify would not reasonably be expected to have a Material Adverse Effect, and (d) has the power and authority to execute, deliver and perform its obligations under each of the Loan Documents and each other agreement or instrument contemplated thereby to which it is or will be a party and, in the case of the Borrower, to borrow and otherwise obtain credit hereunder.

Section 3.02 Authorization. The execution, delivery and performance by the Borrower and each of the Subsidiary Loan Parties and, in the case of Section 3.02(a) and 3.02(b)(i)(B), Holdings (prior to a Qualified IPO), of each of the Loan Documents to which it is a party and the borrowings hereunder (a) have been duly authorized by all corporate, stockholder, partnership or limited liability company action required to be obtained by Holdings, the Borrower and such Subsidiary Loan Parties and (b) will not (i) violate (A) any provision of law, statute, rule or regulation applicable to Holdings, the Borrower or any such Subsidiary Loan Party, (B) the certificate or articles of incorporation or other constitutive documents (including any partnership, limited liability company or operating agreements) or by-laws of Holdings, the Borrower, or any such Subsidiary Loan Party, (C) any applicable order of any court or any rule, regulation or order of any Governmental Authority applicable to the Borrower or any such Subsidiary Loan Party or (D) any provision of any indenture, certificate of designation for preferred stock, agreement or other instrument to which the Borrower or any such Subsidiary Loan Party is a party or by which any of them or any of their property is or may be bound, (ii) result in a breach of or constitute (alone or with due notice or lapse of time or both) a default under, give rise to a right of or result in any cancellation or acceleration of any right or obligation (including any payment) under any such indenture, certificate of designation for preferred stock, agreement or other instrument, where any such conflict, violation, breach or default referred to in clause (i) or (ii) of this Section 3.02(b), would reasonably be expected to have, individually or in the aggregate, a Material Adverse Effect, or (iii) result in the creation or imposition of any Lien upon or with respect to (x) any property or assets now owned or hereafter acquired by the Borrower or any such Subsidiary Loan Party, other than the Liens created by the Loan Documents and Permitted Liens, or (y) any Equity Interests of the Borrower now owned or hereafter acquired by Holdings (prior to a Qualified IPO), other than Liens created by the Loan Documents or Liens permitted by Article VIA.

Section 3.03 Enforceability. This Agreement has been duly executed and delivered by Holdings and the Borrower and constitutes, and each other Loan Document when executed and delivered by the Borrower and each Subsidiary Loan Party that is party thereto will constitute, a legal, valid and binding obligation of such Loan Party enforceable against the Borrower and each such Subsidiary Loan Party in accordance with its terms, subject to (i) the effects of bankruptcy, insolvency, moratorium, reorganization, fraudulent conveyance or other similar laws affecting creditors' rights generally, (ii) general principles of equity (regardless of whether such enforceability is considered in a proceeding in equity or at law), (iii) implied covenants of good faith and fair dealing and (iv) any foreign laws, rules and regulations as they relate to pledges of Equity Interests in Foreign Subsidiaries that are not Loan Parties.

Section 3.04 Governmental Approvals. No action, consent or approval of, registration or filing with or any other action by any Governmental Authority is or will be required for the execution, delivery or performance of each Loan Document, except for (a) the filing of Uniform Commercial Code financing statements, (b) filings with the United States Patent and Trademark Office and the United States Copyright Office and comparable offices in foreign jurisdictions and equivalent filings in foreign jurisdictions, (c) recordation of the Mortgages, (d) such as have been made or obtained and are in full force and effect, (e) such actions, consents and approvals the failure of which to be obtained or made would not reasonably be expected to have a Material Adverse Effect and (f) filings or other actions listed on Schedule 3.04 and any other filings or registrations required by the Security Documents.

Section 3.05 Financial Statements. (a) The audited financial statements consisting of the balance sheet of the Borrower as of December 31, 2016, 2015, and 2014 and the related statements of income and retained earnings, members' equity and cash flow for the years then ended and (b) unaudited financial statements consisting of the balance sheet of the Borrower as of October 31, 2017 and the related statements of income and retained earnings, members' equity and cash flow for the ten-month period then ended, including the notes thereto, if applicable, present fairly in all material respects the consolidated financial position of the Borrower as of the dates and for the periods referred to therein and the results of operations and, if applicable, cash flows for the periods then ended, and, except as set forth on Schedule 3.05, were prepared in accordance with GAAP applied on a consistent basis throughout the periods covered thereby, except, in the case of interim period financial statements, for the absence of notes and for normal year-end adjustments and except as otherwise noted therein.

Section 3.06 No Material Adverse Effect. Since the Closing Date, there has been no event or circumstance that, individually or in the aggregate with other events or circumstances, has had or would reasonably be expected to have a Material Adverse Effect.

Section 3.07 Title to Properties; Possession Under Leases. (a) Each of the Borrower and the Subsidiaries has valid title in fee simple or equivalent to, or valid leasehold interests in, or easements or other limited property interests in, all its Real Properties (including all Mortgaged Properties) and has good and marketable title to its personal property and assets,

in each case, except for Permitted Liens and except for defects in title that do not materially interfere with its ability to conduct its business as currently conducted or to utilize such properties and assets for their intended purposes and except where the failure to have such title would not reasonably be expected to have, individually or in the aggregate, a Material Adverse Effect. All such properties and assets are free and clear of Liens, other than Permitted Liens. The Equity Interests of the Borrower owned by Holdings (prior to a Qualified IPO) are in each case free and clear of Liens, other than Liens permitted by Article VIA.

(b) The Borrower and each of the Subsidiaries has complied with all material obligations under all leases to which it is a party, except where the failure to comply would not reasonably be expected to have Material Adverse Effect, and all such leases are in full force and effect, except leases in respect of which the failure to be in full force and effect would not reasonably be expected to have a Material Adverse Effect. Except as set forth on Schedule 3.07(b), the Borrower and each of the Subsidiaries enjoys peaceful and undisturbed possession under all such leases, other than leases in respect of which the failure to enjoy peaceful and undisturbed possession would not reasonably be expected to have, individually or in the aggregate, a Material Adverse Effect.

(c) As of the Closing Date, none of the Borrower and the Subsidiaries has received any written notice of any pending or contemplated condemnation proceeding affecting any material portion of the Mortgaged Properties or any sale or disposition thereof in lieu of condemnation that remains unresolved as of the Closing Date.

(d) As of the Closing Date, none of the Borrower and the Subsidiaries is obligated under any right of first refusal, option or other contractual right to sell, assign or otherwise dispose of any Mortgaged Property or any interest therein, except as permitted under Section 6.02 or 6.05.

(e) Schedule 1.01(B) lists each Material Real Property, if any, owned by any Loan Party as of the Closing Date.

Section 3.08 Subsidiaries. (a) Schedule 3.08(a) sets forth as of the Closing Date the name and jurisdiction of incorporation, formation or organization of each subsidiary of the Borrower and, as to each such subsidiary, the percentage of each class of Equity Interests owned by the Borrower or by any such subsidiary.

(b) As of the Closing Date, after giving effect to the Transactions to be consummated on or prior to the Closing Date, there are no outstanding subscriptions, options, warrants, calls, rights or other agreements or commitments (other than stock options granted to employees or directors (or entities controlled by directors) and shares held by directors (or entities controlled by directors)) relating to any Equity Interests of Holdings, the Borrower or any of the Subsidiaries, except as set forth on Schedule 3.08(b).

Section 3.09 Litigation; Compliance with Laws. (a) There are no actions, suits or proceedings at law or in equity or by or on behalf of any Governmental Authority or in arbitration now pending, or, to the knowledge of the Borrower, threatened in writing against any such person or any of the Subsidiaries or any business, property or rights of any such person (i) that involve any Loan Document or the Transactions, except as set forth on Schedule 3.09(a), or (ii) that would reasonably be expected to have, individually or in the aggregate, a Material Adverse Effect.



(b) None of the Borrower, the Subsidiaries and their respective properties or assets is in violation of (nor will the continued operation of their material properties and assets as currently conducted violate) any law, rule or regulation (including any zoning, building, ordinance, code or approval or any building permit, but excluding any Environmental Laws, which are the subject of Section 3.16) or any restriction of record or agreement affecting any Mortgaged Property, or is in default with respect to any judgment, writ, injunction or decree of any Governmental Authority, where such violation or default would reasonably be expected to have, individually or in the aggregate, a Material Adverse Effect.

Section 3.10 Federal Reserve Regulations. Neither the making of any Loan hereunder nor the use of the proceeds thereof will violate the provisions of Regulation T, Regulation U or Regulation X of the Board.

Section 3.11 Investment Company Act. None of Holdings (prior to a Qualified IPO), the Borrower and the Subsidiaries is required to be registered as an "investment company" within the meaning of the Investment Company Act of 1940, as amended.

Section 3.12 Use of Proceeds. The Borrower will use the proceeds of the Loans made after the Closing Date (a) to provide for working capital and (b) for general limited liability company purposes (including for acquisitions permitted hereunder).

Section 3.13 Tax Returns. Except as set forth on Schedule 3.13:

(a) Except as would not, individually or in the aggregate, reasonably be expected to result in a Material Adverse Effect, the Borrower and each of the Subsidiaries has filed or caused to be filed all federal, state, local and non-U.S. Tax returns required to have been filed by it (including in its capacity as withholding agent) and each such Tax return is true and correct;

(b) Except as would not, individually or in the aggregate, reasonably be expected to result in a Material Adverse Effect, the Borrower and each of the Subsidiaries has timely paid or caused to be timely paid all Taxes shown to be due and payable by it on the returns referred to in clause (a) and all other Taxes or assessments (or made adequate provision (in accordance with GAAP) for the payment of all Taxes due), except Taxes or assessments that are being contested in good faith by appropriate proceedings in accordance with Section 5.03 and for which the Borrower or any of the Subsidiaries (as the case may be) has set aside on its books adequate reserves in accordance with GAAP; and

(c) Other than as would not be, individually or in the aggregate, reasonably expected to have a Material Adverse Effect, as of the Closing Date, with respect to the Borrower and each of the Subsidiaries, there are no claims being asserted in writing with respect to any Taxes.

Section 3.14 No Material Misstatements. (a) All written factual information (other than the Projections, forward looking information and information of a general economic nature or general industry nature) (the “Information”) concerning the Borrower, the Subsidiaries, the Transactions and any other transactions contemplated hereby prepared by or on behalf of the foregoing or their representatives and made available to any Lenders or the Administrative Agent in connection with the Transactions or the other transactions contemplated hereby, when taken as a whole, was true and correct in all material respects, as of the date such Information was furnished to the Lenders and as of the Closing Date and did not, taken as a whole, contain any untrue statement of a material fact as of any such date or omit to state a material fact necessary in order to make the statements contained therein, taken as a whole, not materially misleading in light of the circumstances under which such statements were made (giving effect to all supplements and updates provided thereto).

(b) The Projections and other forward-looking information and information of a general economic nature prepared by or on behalf of the Borrower or any of its representatives and that have been made available to any Lenders or the Administrative Agent in connection with the Transactions or the other transactions contemplated hereby (i) have been prepared in good faith based upon assumptions believed by the Borrower to be reasonable as of the date thereof (it being understood that such Projections are as to future events and are not to be viewed as facts, such Projections are subject to significant uncertainties and contingencies and that actual results during the period or periods covered by any such Projections may differ significantly from the projected results, and that no assurance can be given that the projected results will be realized), as of the date such Projections and information were furnished to the Lenders and as of the Closing Date, and (ii) as of the Closing Date, have not been modified in any material respect by the Borrower.

Section 3.15 Employee Benefit Plans. Except as would not reasonably be expected, individually or in the aggregate, to have a Material Adverse Effect: (i) no Reportable Event has occurred during the past five years as to which the Borrower, any of its Subsidiaries or any ERISA Affiliate was required to file a report with the PBGC; (ii) no ERISA Event has occurred or is reasonably expected to occur; and (iii) none of the Borrower, the Subsidiaries or any of their ERISA Affiliates has received any written notification that any Multiemployer Plan has been terminated within the meaning of Title IV of ERISA.

Section 3.16 Environmental Matters. Except as to matters that would not reasonably be expected to have, individually or in the aggregate, a Material Adverse Effect: (i) no written notice, request for information, order, complaint or penalty has been received by the Borrower or any of the Subsidiaries, and there are no judicial, administrative or other actions, suits or proceedings pending or, to the Borrower’s knowledge, threatened, (A) which allege a violation of or liability under any Environmental Laws and (B) relating to the Borrower or any of the Subsidiaries, (ii) each of the Borrower and the Subsidiaries has all environmental permits, licenses and other approvals necessary for its operations to comply with all Environmental Laws (“Environmental Permits”) and is in compliance with the terms of such Environmental Permits and with all other Environmental Laws, (iii) except as set forth on Schedule 3.16, no Hazardous Material has been Released at, on or under any property currently owned or, to the Borrower’s knowledge, formerly owned, operated or leased by the Borrower or any of the Subsidiaries that

would reasonably be expected to give rise to any cost, liability or obligation of the Borrower or any of the Subsidiaries under any Environmental Laws or Environmental Permits, and no Hazardous Material has been generated, used, treated, stored, handled, disposed of or controlled, transported or Released by the Borrower or any of the Subsidiaries at any location in a manner that would reasonably be expected to give rise to any cost, liability or obligation of the Borrower or any of the Subsidiaries under any Environmental Laws or Environmental Permits, (iv) there are no agreements in which the Borrower or any of the Subsidiaries has expressly assumed or undertaken responsibility for any known or reasonably likely liability or Obligation of any other person arising under or relating to Environmental Laws, which in any such case has not been made available to the Administrative Agent prior to the Closing Date, and (v) there has been no material written environmental assessment or audit conducted (other than customary assessments not revealing anything that would reasonably be expected to result in a Material Adverse Effect), by or on behalf and in the possession, custody or control of the Borrower or any of the Subsidiaries of any property currently or, to the Borrower's knowledge, formerly owned or leased by the Borrower or any of the Subsidiaries that has not been made available to the Administrative Agent prior to the Closing Date.

Section 3.17 Security Documents. (a) The Collateral Agreement and the Holdings Guarantee and Pledge Agreement are, in each case, effective to create in favor of the Collateral Agent (for the benefit of the Secured Parties) a legal, valid and enforceable security interest in the Collateral described therein and proceeds thereof. As of the Closing Date, in the case of the Pledged Collateral described in the Collateral Agreement and the Holdings Guarantee and Pledge Agreement, respectively, when certificates or promissory notes, as applicable, representing such Pledged Collateral and required to be delivered under the applicable Security Document are delivered to the Collateral Agent, and in the case of the other Collateral described in the Collateral Agreement (other than the Intellectual Property), when financing statements and other filings specified in the Perfection Certificate are filed in the offices specified in the Perfection Certificate, the Collateral Agent (for the benefit of the Secured Parties) shall have a fully perfected Lien on, and security interest in, all right, title and interest of the Loan Parties in such Collateral and, subject to Section 9-315 of the New York Uniform Commercial Code, the proceeds thereof, as security for the Obligations to the extent perfection can be obtained by filing Uniform Commercial Code financing statements, in each case prior and superior in right to the Lien of any other person (except (x) Liens having priority by operation of law and (y) in the case of Collateral other than certificated securities and instruments of which the Collateral Agent has possession, Permitted Liens).

(b) When the Collateral Agreement or an ancillary document thereunder is properly filed in the United States Patent and Trademark Office and the United States Copyright Office, and, with respect to Collateral in which a security interest cannot be perfected by such filings, upon the proper filing of the financing statements referred to in clause (a) above, the Collateral Agent (for the benefit of the Secured Parties) shall have a fully perfected (subject to exceptions arising from defects in the chain of title, which defects in the aggregate do not constitute a Material Adverse Effect hereunder) Lien on, and security interest in, all right, title and interest of the Loan Parties thereunder in the material domestic Intellectual Property, in each case prior and superior in right to the Lien of any other person, except for Permitted Liens (it being understood that subsequent recordings in the United States Patent and Trademark Office and the United States Copyright Office may be necessary to perfect a Lien on material registered trademarks and patents, trademark and patent applications and registered copyrights acquired by the Loan Parties after the Closing Date).

(c) The Mortgages, if any, executed and delivered on the Closing Date are, and the Mortgages executed and delivered after the Closing Date pursuant to Section 5.10 shall be, effective to create in favor of the Collateral Agent (for the benefit of the Secured Parties) legal, valid and enforceable Liens on all of the Loan Parties' rights, titles and interests in and to the Mortgaged Property thereunder and the proceeds thereof, and when such Mortgages are filed or recorded in the proper real estate filing or recording offices, and all relevant mortgage taxes and recording charges are duly paid, the Collateral Agent (for the benefit of the Secured Parties) shall have valid Liens with record notice to third parties on, and security interests in, all rights, titles and interests of the Loan Parties in such Mortgaged Property and, to the extent applicable, subject to Section 9-315 of the Uniform Commercial Code, the proceeds thereof, in each case prior and superior in right to the Lien of any other person, except for Permitted Liens.

(d) Notwithstanding anything herein (including this Section 3.16) or in any other Loan Document to the contrary, no Borrower or any other Loan Party makes any representation or warranty as to the effects of perfection or non-perfection, the priority or the enforceability of any pledge of or security interest in any Equity Interests of any Foreign Subsidiary, or as to the rights and remedies of the Agents or any Lender with respect thereto, under foreign law.

Section 3.18 Location of Real Property.

(a) The Perfection Certificate lists correctly, in all material respects, as of the Closing Date all Material Real Property owned by the Borrower and the Subsidiary Loan Parties and the addresses thereof. As of the Closing Date, the Borrower and the Subsidiary Loan Parties (if any) own in fee all the Real Property set forth as being owned by them in the Perfection Certificate except to the extent set forth therein.

(b) The Perfection Certificate lists correctly, in all material respects, as of the Closing Date, all Real Property leased by the Borrower and the Subsidiary Loan Parties (if any) and the addresses thereof. As of the Closing Date, the Borrower and the Subsidiary Loan Parties (if any) have in all material respects valid leases in all the Real Property set forth as being leased by them in the Perfection Certificate except to the extent set forth therein.

Section 3.19 Solvency. (a) Immediately after giving effect to the Transactions on the Closing Date, (i) the fair value of the assets of the Borrower and its Subsidiaries on a consolidated basis, at a fair valuation, will exceed the debts and liabilities, direct, subordinated, contingent or otherwise, of the Borrower and its Subsidiaries on a consolidated basis; (ii) the present fair saleable value of the property of the Borrower and its Subsidiaries on a consolidated basis will be greater than the amount that will be required to pay the probable liability of the Borrower and its Subsidiaries on a consolidated basis on their debts and other liabilities, direct, subordinated, contingent or otherwise, as such debts and other liabilities become absolute and matured; (iii) the Borrower and its Subsidiaries on a consolidated basis will be able to pay their

debts and liabilities, direct, subordinated, contingent or otherwise, as such debts and liabilities become absolute and matured; and (iv) the Borrower and its Subsidiaries on a consolidated basis will not have unreasonably small capital with which to conduct the businesses in which they are engaged as such businesses are now conducted and are proposed to be conducted following the Closing Date.

(b) As of the Closing Date, immediately after giving effect to the consummation of the Transactions, the Borrower does not intend to, and the Borrower does not believe that it or any of its Subsidiaries will, incur debts beyond its ability to pay such debts as they mature, taking into account the timing and amounts of cash to be received by it or any such Subsidiary and the timing and amounts of cash to be payable on or in respect of its Indebtedness or the Indebtedness of any such Subsidiary.

Section 3.20 Labor Matters. Except as, individually or in the aggregate, would not reasonably be expected to have a Material Adverse Effect: (a) there are no strikes or other labor disputes pending or threatened against the Borrower or any of the Subsidiaries; (b) the hours worked and payments made to employees of the Borrower and the Subsidiaries have not been in violation of the Fair Labor Standards Act or any other applicable law dealing with such matters; and (c) all payments due from the Borrower or any of the Subsidiaries or for which any claim may be made against the Borrower or any of the Subsidiaries, on account of wages and employee health and welfare insurance and other benefits have been paid or accrued as a liability on the books of the Borrower or such Subsidiary to the extent required by GAAP. Except as, individually or in the aggregate, would not reasonably be expected to have a Material Adverse Effect, the consummation of the Transactions will not give rise to a right of termination or right of renegotiation on the part of any union under any material collective bargaining agreement to which the Borrower or any of the Subsidiaries (or any predecessor) is a party or by which the Borrower or any of the Subsidiaries (or any predecessor) is bound.

Section 3.21 Insurance. Schedule 3.21 sets forth a true, complete and correct description, in all material respects, of all material insurance (excluding any title insurance) maintained by or on behalf of the Borrower or the Subsidiaries as of the Closing Date. As of such date, such insurance is in full force and effect.

Section 3.22 No Default. No Default or Event of Default has occurred and is continuing or would result from the consummation of the transactions contemplated by this Agreement or any other Loan Document.

Section 3.23 Intellectual Property; Licenses, Etc. Except as would not reasonably be expected to have a Material Adverse Effect or as set forth in Schedule 3.23, (a) the Borrower and each of the Subsidiaries owns, or possesses the right to use, all Intellectual Property that is used or held for use in, or is otherwise reasonably necessary for, the present conduct of their respective businesses, (b) to the knowledge of the Borrower, the Borrower and the Subsidiaries are not interfering with, infringing upon, misappropriating or otherwise violating any Intellectual Property of any person, and (c) no claim or litigation regarding any of the foregoing is pending or, to the knowledge of the Borrower, threatened.

Section 3.24 Senior Debt. The Loan Obligations under this Agreement constitute “Senior Debt” (or the equivalent thereof) under the documentation governing any Material Indebtedness of any Loan Party permitted to be incurred hereunder constituting Indebtedness that is subordinated in right of payment to the Loan Obligations.

Section 3.25 USA PATRIOT Act; OFAC.

(a) On the Closing Date, each Loan Party is in compliance in all material respects with the material applicable provisions of the USA PATRIOT Act, and the Borrower has provided to the Administrative Agent all information related to the Loan Parties (including names, addresses and tax identification numbers (if applicable)) reasonably requested in writing by the Administrative Agent not less than ten (10) Business Days prior to the Closing Date and mutually agreed to be required under “know your customer” and anti-money laundering rules and regulations, including the USA PATRIOT Act, to be obtained by the Administrative Agent or any Lender.

(b) None of Holdings, the Borrower or any of its Subsidiaries nor, to the knowledge of the Borrower, any director, officer, agent, employee or Affiliate of the Borrower or any of the Subsidiaries is currently the subject of any sanctions administered by the Office of Foreign Assets Control of the U.S. Treasury Department (“OFAC”), the U.S. Department of State, the European Union, the United Nations Security Council or Her Majesty’s Treasury (collectively, “Sanctions”), or is located, organized or resident in a country or territory that is, or whose government is, the subject of Sanctions. The Borrower will not directly or indirectly use the proceeds of the Loans or the Letters of Credit or otherwise make available such proceeds to any person to finance the activities of any person that is currently the target of any Sanctions, or to fund, finance or facilitate any activities, business or transaction with or in any country that is the target of the Sanctions, to the extent such activities, businesses or transaction would be prohibited by Sanctions, or in any manner that would result in the violation of any Sanctions applicable to any party hereto.

Section 3.26 Foreign Corrupt Practices Act. Holdings, the Borrower and its Subsidiaries, and, to the knowledge of the Borrower or any of its Subsidiaries, their directors, officers, agents or employees, are in compliance with the U.S. Foreign Corrupt Practices Act of 1977 or similar law of a jurisdiction in which the Borrower or any of its Subsidiaries conduct their business and to which they are lawfully subject (“Anti-Corruption Laws”), in each case, in all material respects. Borrower has instituted and maintains policies and procedures designed to ensure compliance by Holdings, the Borrower, its Subsidiaries and their respective directors, officers, employees and agents with Anti-Corruption Laws. No part of the proceeds of the Loans made hereunder will be used, directly or indirectly, for any payments to any governmental official or employee, political party, official of a political party, candidate for political office, or anyone else acting in an official capacity, in order to obtain, retain or direct business or obtain any improper advantage, in violation of any provision of Anti-Corruption Laws.

ARTICLE IV

*Conditions of Lending*

Section 4.01 Conditions Precedent to Credit Events After the Closing Date. The obligations of (a) the Lenders (including the Swingline Lender) to make Loans hereunder (except for Agent Advances) and (b) any Issuing Bank to issue Letters of Credit or increase the stated amounts of Letters of Credit (each, a "Credit Event"), in each case after the Closing Date, are subject to the satisfaction (or waiver in accordance with Section 9.08) of the following conditions:

(a) The Administrative Agent shall have received, in the case of a Borrowing, a Borrowing Request as required by Section 2.03 (or a Borrowing Request shall have been deemed given in accordance with the last paragraph of Section 2.03(b)) or, in the case of the issuance of a Letter of Credit, the applicable Issuing Bank and the Administrative Agent shall have received a notice requesting the issuance of such Letter of Credit as required by Section 2.05(b).

(b) Except for any Credit Event in respect of an amendment, extension or renewal of a Letter of Credit without any increase in the stated amount of such Letter of Credit, the representations and warranties set forth in the Loan Documents shall be true and correct in all material respects as of such date, with the same effect as though made on and as of such date, except to the extent such representations and warranties expressly relate to an earlier date (in which case such representations and warranties shall be true and correct in all material respects as of such earlier date).

(c) Except for any Credit Event in respect of an amendment, extension or renewal of a Letter of Credit without any increase in the stated amount of such Letter of Credit, at the time of and immediately after such Credit Event, no Event of Default or Default shall have occurred and be continuing.

(d) Each Credit Event that occurs after the Closing Date shall be deemed to constitute a representation and warranty by the Borrower on the date of such Credit Event, as to the matters specified in clauses (b) and (c) of this Section 4.01.

(e) After giving effect to such Borrowing or such issuance of a Letter of Credit, the aggregate Revolving Facility Credit Exposure shall not exceed the Maximum Availability.

Section 4.02 Conditions Precedent to the Effective Date. The effectiveness of this Agreement, all Commitments hereunder, and any other Loan Document (other than the Fee Letter) executed in connection herewith, is subject to the satisfaction (or waiver in accordance with Section 10.08) of the following conditions:

(a) The Administrative Agent (or its counsel) shall have received (1) a duly executed counterpart of this Agreement from each of the Administrative Agent, the Lenders party hereto as of the Effective Date, and Holdings, and (2) a duly executed counterpart of the Fee Letter, from each of the Administrative Agent and Holdings.

(b) The representations and warranties of Holdings set forth in Sections 3.01(a) and (d), 3.02(a) and (b)(i)(B), 3.03, 3.11, 3.22, the final sentence of 3.25(b) and the final sentence of 3.26 of this Agreement shall be true and correct in all material respects as of the Effective Date, with the same effect as though made on and as of such date, except to the extent such representations and warranties expressly relate to an earlier date (in which case such representations and warranties shall be true and correct in all material respects as of such earlier date).

(c) No Event of Default or Default shall have occurred and be continuing.

(d) The Administrative Agent (or its counsel) shall have received a certificate from a Responsible Officer of Holdings certifying as to the matters specified in clauses (b) and (c) of this Section 4.02.

(e) Holdings and the Seller shall have entered into the Purchase Agreement simultaneously or substantially concurrently with the effectiveness of this Agreement.

For purposes of determining compliance with the conditions specified in this Section 4.02, each Lender shall be deemed to have consented to, approved or accepted or to be satisfied with each document or other matter required thereunder to be consented to or approved by or acceptable or satisfactory to the Lenders unless an officer of the Administrative Agent responsible for the transactions contemplated by the Loan Documents shall have received notice from such Lender prior to the Closing Date specifying its objection thereto.

Section 4.03 Conditions Precedent to the Closing Date. The occurrence of the Closing Date is subject to the satisfaction (or waiver in accordance with Section 9.08) of the following conditions:

(a) The Administrative Agent (or its counsel) shall have received (x) a joinder to this Agreement in the form of Exhibit L executed by the Borrower and (y) Schedules 1.01(G) and 1.01(H) to this Agreement.

(b) The Administrative Agent shall have received, on behalf of itself and the Lenders and each Issuing Bank, a favorable written opinion of each of (1) Paul, Weiss, Rifkind, Wharton & Garrison LLP, special counsel for the Loan Parties and (2) Minnesota counsel for the Loan Parties, in each case (A) dated the Closing Date, (B) addressed to each Issuing Bank, the Administrative Agent and the Lenders on the Closing Date and (C) in form and substance reasonably satisfactory to the Administrative Agent, covering such matters relating to the Loan Documents as the Administrative Agent shall reasonably request.



(c) The Administrative Agent shall have received a certificate of the Secretary or Assistant Secretary or similar officer of each Loan Party dated the Closing Date and certifying:

(i) a copy of the certificate or articles of incorporation, certificate of limited partnership, certificate of formation or other equivalent constituent and governing documents, including all amendments thereto, of such Loan Party, (1) in the case of a corporation, certified as of a recent date by the Secretary of State (or other similar official) of the jurisdiction of its organization, or (2) otherwise certified by the Secretary or Assistant Secretary of such Loan Party or other person duly authorized by the constituent documents of such Loan Party,

(ii) a certificate as to the good standing (to the extent such concept or a similar concept exists under the laws of such jurisdiction) of such Loan Party as of a recent date from such Secretary of State (or other similar official),

(iii) that attached thereto is a true and complete copy of the by- laws (or partnership agreement, limited liability company agreement or other equivalent constituent and governing documents) of such Loan Party as in effect on the Closing Date and at all times since a date prior to the date of the resolutions described in clause (iv) below,

(iv) that attached thereto is a true and complete copy of resolutions (or equivalent documentation) duly adopted by the Board of Directors (or equivalent governing body) of such Loan Party (or its managing general partner or managing member) authorizing the execution, delivery and performance of the Loan Documents dated as of the Closing Date to which such person is a party and, in the case of the Borrower, the borrowings hereunder, and that such resolutions (or equivalent documentation) have not been modified, rescinded or amended and are in full force and effect on the Closing Date,

(v) as to the incumbency and specimen signature of each officer executing any Loan Document or any other document delivered in connection herewith on behalf of such Loan Party, and

(vi) as to the absence of any pending proceeding for the dissolution or liquidation of such Loan Party or, to the knowledge of such person, threatening the existence of such Loan Party.

(d) The Administrative Agent shall have received a completed Perfection Certificate, dated the Closing Date and signed by a Responsible Officer of the Borrower, together with all attachments contemplated thereby, and the results of a search of the Uniform Commercial Code (or equivalent), tax and judgment, United States Patent and Trademark Office and United States Copyright Office filings made with respect to the Loan Parties in the jurisdictions contemplated by the Perfection Certificate and copies of the financing statements (or similar documents) disclosed by such search and evidence reasonably satisfactory to the Administrative Agent that the Liens indicated by such financing statements (or similar documents) are Permitted Liens or have been, or will be simultaneously or substantially concurrently with the closing under this Agreement, released (or arrangements reasonably satisfactory to the Administrative Agent for such release shall have been made).

(e) The Acquisition shall be consummated simultaneously or substantially concurrently with the closing under this Agreement in accordance with applicable law and the terms and conditions of the Acquisition as set forth in the Purchase Agreement, without giving effect to any amendment, waiver, consent or other modification thereof by the Borrower that is materially adverse to the interests of the Arranger and the Lenders (in their capacities as such) unless it is approved by the Arranger (which approval shall not be unreasonably withheld or delayed).

(f) Prior to, simultaneously, or substantially concurrently with, the closing under this Agreement, the Co-Investors shall have contributed an aggregate amount in cash of not less than \$240,000,000 directly or indirectly to Holdings in the form of cash common equity of Holdings, or other equity of Holdings on terms reasonably acceptable to the Administrative Agent on or prior to the Closing Date (the "Equity Financing").

(g) On the Closing Date, after giving effect to the Transactions and the other transactions contemplated hereby to be consummated on or prior to the Closing Date, none of Holdings, the Borrower or any of the Subsidiaries shall have any Indebtedness of the type described in clause (a) of the definition thereof other than (i) the Loans and other extensions of credit under this Agreement, (ii) Indebtedness permitted to be incurred or outstanding on or prior to the Closing Date pursuant to the Purchase Agreement and (iii) other Indebtedness permitted under Section 6.01 or approved by the Arranger in its reasonable discretion. Without limiting the foregoing or clause (d) above, the Administrative Agent shall have received an executed payoff letter with respect to the Existing Credit Facility in form and substance reasonably satisfactory to the Administrative Agent, and, simultaneously or substantially concurrently with the closing under this Agreement, the principal, accrued and unpaid interest, fees and other amounts, other than contingent obligations that by their terms survive the termination of the Existing Credit Facility, will be repaid in full and all commitments to extend credit thereunder will be terminated and any security interests and guarantees in connection therewith shall be terminated and/or released.

(h) The Lenders shall have received a solvency certificate substantially in the form of Exhibit C and signed by a Financial Officer of the Borrower confirming the solvency of the Borrower and the Subsidiaries on a consolidated basis after giving effect to the Transactions to be consummated on or prior to the Closing Date.

(i) The Agents shall have received all fees payable thereto or to any Lender on or prior to the Closing Date and, to the extent invoiced, all other amounts due and payable pursuant to the Loan Documents on or prior to the Closing Date, including, to the extent invoiced at least three Business Days prior to the Closing Date, reimbursement or payment of all reasonable and documented out-of-pocket expenses (including reasonable fees, charges and disbursements of Cahill Gordon & Reindel LLP) required to be reimbursed or paid by the Loan Parties hereunder or under any Loan Document.

(j) Except as set forth in Schedule 5.10 (which, for the avoidance of doubt, shall override the applicable clauses of the definition of “Collateral and Guarantee Requirement” for the purposes of this Section 4.03) and subject to the grace periods and post-closing periods set forth in such definition, the Collateral and Guarantee Requirement shall be satisfied (or waived) as of the Closing Date.

(k) The Administrative Agent shall have received no later than the day before the Closing Date all documentation and other information required by Section 3.25(a), to the extent such information has been requested not less than ten (10) Business Days prior to the Closing Date.

(l) The representations and warranties set forth in the Loan Documents shall be true and correct in all material respects as of such the Closing Date, with the same effect as though made on and as of such date, except to the extent such representations and warranties expressly relate to an earlier date (in which case such representations and warranties shall be true and correct in all material respects as of such earlier date).

(m) No Event of Default or Default shall have occurred and be continuing.

(n) The Administrative Agent (or its counsel) shall have received a certificate from a Responsible Officer of the Borrower certifying as to the matters specified in clauses (l) and (m) of this Section 4.03.

For the avoidance of doubt, if the Closing Date has not occurred on or prior to the Outside Date, then the Closing Date shall not occur, and the Commitments and this Agreement (other than the provisions hereof that expressly survive termination of this Agreement) shall terminate on such Outside Date in accordance with Section 2.08 hereof.

For purposes of determining compliance with the conditions specified in this Section 4.03, each Lender shall be deemed to have consented to, approved or accepted or to be satisfied with each document or other matter required thereunder to be consented to or approved by or acceptable or satisfactory to the Lenders unless an officer of the Administrative Agent responsible for the transactions contemplated by the Loan Documents shall have received notice from such Lender prior to the Closing Date specifying its objection thereto.

## ARTICLE V

### *Affirmative Covenants*

The Borrower covenants and agrees with each Lender that, from and after the Closing Date and until the Termination Date, unless the Required Lenders shall otherwise consent in writing, the Borrower will, and will cause each of the Subsidiaries to:

Section 5.01 Existence; Business and Properties. (a) Do or cause to be done all things necessary to preserve, renew and keep in full force and effect its legal existence, except, in the case of a Subsidiary of the Borrower, where the failure to do so would not reasonably be expected to have a Material Adverse Effect, and except as otherwise permitted under Section 6.05, and except for the liquidation or dissolution of Subsidiaries if the assets of such Subsidiaries to the extent they exceed estimated liabilities are acquired by the Borrower or a Wholly Owned Subsidiary of the Borrower in such liquidation or dissolution; provided, that Subsidiary Loan Parties may not be liquidated into Subsidiaries that are not Loan Parties and Domestic Subsidiaries may not be liquidated into Foreign Subsidiaries (except in each case as permitted under Section 6.05).

(b) Except where the failure to do so would not reasonably be expected to have a Material Adverse Effect, do or cause to be done all things necessary to (i) lawfully obtain, preserve, renew, extend and keep in full force and effect the permits, franchises, authorizations, Intellectual Property, licenses and rights with respect thereto necessary to the normal conduct of its business, and (ii) at all times maintain, protect and preserve all property necessary to the normal conduct of its business and keep such property in good repair, working order and condition (ordinary wear and tear excepted), from time to time make, or cause to be made, all needful and proper repairs, renewals, additions, improvements and replacements thereto necessary in order that the business carried on in connection therewith, if any, may be properly conducted at all times (in each case except as permitted by this Agreement).

Section 5.02 Insurance. (a) Maintain, with financially sound and reputable insurance companies, insurance (subject to customary deductibles and retentions) in such amounts and against such risks as are customarily maintained by similarly situated companies engaged in the same or similar businesses operating in the same or similar locations, cause the Collateral Agent to be listed as a co-loss payee on property and casualty policies and as an additional insured on liability policies. Notwithstanding the foregoing, the Borrower and the Subsidiaries may self-insure with respect to such risks with respect to which companies of established reputation engaged in the same general line of business in the same general area usually self-insure.

(b) Except as the Collateral Agent may agree in its reasonable discretion, cause all such property and casualty insurance policies to be endorsed or otherwise amended to include a “standard” or “New York” lender’s loss payable endorsement, in form and substance reasonably satisfactory to the Collateral Agent, deliver a certificate of an insurance broker to the Collateral Agent; cause each such policy covered by this clause (b) to provide that it shall not be cancelled or not renewed upon less than 30 days’ prior written notice thereof by the insurer to the Collateral Agent; deliver to the Collateral Agent, prior to or concurrently with the cancellation or nonrenewal of any such policy of insurance covered by this clause (b), a copy of a renewal or replacement policy (or other evidence of renewal of a policy previously delivered to the Collateral Agent), or insurance certificate with respect thereto, together with evidence satisfactory to the Collateral Agent of payment of the premium therefor, in each case of the foregoing, to the extent customarily maintained, purchased or provided to, or at the request of, lenders by similarly situated companies in connection with credit facilities of this nature.

(c) If any portion of any Mortgaged Property is at any time located in an area identified by the Federal Emergency Management Agency (or any successor agency) as a special flood hazard area (each a "Special Flood Hazard Area") with respect to which flood insurance has been made available under the National Flood Insurance Act of 1968 (as now or hereafter in effect or successor act thereto), (i) maintain, or cause to be maintained, with a financially sound and reputable insurer, flood insurance in an amount and otherwise sufficient to comply with all applicable rules and regulations promulgated pursuant to the Flood Insurance Laws and (ii) deliver to the Collateral Agent evidence of such compliance in form and substance reasonably acceptable to the Collateral Agent.

(d) In connection with the covenants set forth in this Section 5.02, it is understood and agreed that:

(i) none of the Collateral Agent, the Lenders, the Issuing Bank and their respective agents or employees shall be liable for any loss or damage insured by the insurance policies required to be maintained under this Section 5.02, it being understood that (A) the Loan Parties shall look solely to their insurance companies or any other parties other than the aforesaid parties for the recovery of such loss or damage and (B) such insurance companies shall have no rights of subrogation against the Collateral Agent, the Lenders, any Issuing Bank or their agents or employees. If, however, the insurance policies, as a matter of the internal policy of such insurer, do not provide waiver of subrogation rights against such parties, as required above, then each of Holdings and the Borrower, on behalf of itself and on behalf of each of its Subsidiaries, hereby agrees, to the extent permitted by law, to waive, and further agrees to cause each of their Subsidiaries to waive, its right of recovery, if any, against the Collateral Agent, the Lenders and their agents and employees;

(ii) the designation of any form, type or amount of insurance coverage by the Collateral Agent (including acting in the capacity as the Collateral Agent) under this Section 5.02 shall in no event be deemed a representation, warranty or advice by the Collateral Agent or the Lenders that such insurance is adequate for the purposes of the business of Holdings, the Borrower and the Subsidiaries or the protection of their properties; and

(iii) the amount and type of insurance that the Borrower and its Subsidiaries has in effect as of the Closing Date satisfies for all purposes the requirements of this Section 5.02.

Section 5.03 Taxes. Pay its obligations in respect of all Tax liabilities, assessments and governmental charges, before the same shall become delinquent or in default, except where (i) the amount or validity thereof is being contested in good faith by appropriate proceedings and the Borrower or a Subsidiary thereof has set aside on its books adequate reserves therefor in accordance with GAAP or (ii) the failure to make payment could not reasonably be expected, individually or in the aggregate, to result in a Material Adverse Effect.

Section 5.04 Financial Statements, Reports, etc. Furnish to the Administrative Agent (which will promptly furnish such information to the Lenders):

(a) within 120 days after the end of the fiscal year ending December 31, 2017 and within 90 days after the end of each fiscal year thereafter, a consolidated balance sheet and related statements of operations, cash flows and owners' equity showing the financial position of the Borrower and its Subsidiaries as of the close of such fiscal year and the consolidated results of their operations during such year and, starting with the fiscal year ending December 31, 2018, setting forth in comparative form the corresponding figures for the prior fiscal year, in each case, together with a Metric Report with respect thereto, which consolidated balance sheet and related statements of operations, cash flows and owners' equity shall be audited by independent public accountants of recognized national standing and accompanied by an opinion of such accountants (which opinion shall not be qualified as to scope of audit or as to the status of the Borrower or any Material Subsidiary as a going concern, other than solely with respect to, or resulting solely from, an upcoming maturity date under any series of Indebtedness occurring within one year from the time such opinion is delivered or any potential inability to satisfy a financial maintenance covenant on a future date or in a future period) to the effect that such consolidated financial statements fairly present, in all material respects, the financial position and results of operations of the Borrower and its Subsidiaries on a consolidated basis in accordance with GAAP (it being understood that the delivery by the Borrower of annual reports on Form 10-K of the Borrower and its consolidated Subsidiaries shall satisfy the requirements of this Section 5.04(a) to the extent such annual reports include the information specified herein);

(b) within 90 days after the end of the first full fiscal quarter ending after the Closing Date, and within 60 days after the end of each of the first three fiscal quarters of each fiscal year (commencing with the second full fiscal quarter ending after the Closing Date), a consolidated balance sheet and related statements of operations and cash flows showing the financial position of the Borrower and its subsidiaries as of the close of such fiscal quarter and the consolidated results of their operations during such fiscal quarter and the then-elapsed portion of the fiscal year and, starting with the fifth full fiscal quarter ending after the Closing Date, setting forth in comparative form the corresponding figures for the corresponding periods of the prior fiscal year, all of which shall be in reasonable detail and which consolidated balance sheet and related statements of operations and cash flows shall be certified by a Financial Officer of the Borrower on behalf of the Borrower as fairly presenting, in all material respects, the financial position and results of operations of the Borrower and its Subsidiaries on a consolidated basis in accordance with GAAP (subject to normal year-end audit adjustments and the absence of footnotes) in each case, together with a Metric Report with respect thereto (it being understood that the delivery by the Borrower of quarterly reports on Form 10-Q of the Borrower and its consolidated Subsidiaries shall satisfy the requirements of this Section 5.04(b) to the extent such quarterly reports include the information specified herein);

(c) (x) concurrently with any delivery of financial statements under clause (a) or (b) above, a certificate of a Financial Officer of the Borrower (i) certifying that no Event of Default or Default has occurred since the date of the last certificate delivered pursuant to this Section 5.04(c) or, if such an Event of Default or Default has occurred, specifying the nature and extent thereof and any corrective action taken or proposed to be taken with respect thereto and (ii) commencing with the end of the first full fiscal quarter after the Closing Date, setting forth computations in reasonable detail of the Financial Covenant and setting forth the calculation of Availability as of the end of such quarter and (y) concurrently with any delivery of financial statements under clause (a) above, if the accounting firm is not restricted from providing such a certificate by its policies office, a certificate of the accounting firm opining on or certifying such statements stating whether they obtained knowledge during the course of their examination of such statements of any Default or Event of Default (which certificate may be limited to accounting matters and disclaim responsibility for legal interpretations);

(d) promptly after the same become publicly available, copies of all periodic and other publicly available reports, proxy statements and, to the extent requested by the Administrative Agent, other materials filed by Holdings (prior to a Qualified IPO), the Borrower or any of the Subsidiaries with the SEC, or after an initial public offering, distributed to its stockholders generally, as applicable; provided, however, that such reports, proxy statements, filings and other materials required to be delivered pursuant to this clause (d) shall be deemed delivered for purposes of this Agreement when posted to the website of the Borrower (or Holdings or any Parent Entity referred to in Section 5.04(h)) or the website of the SEC and written notice of such posting has been delivered to the Administrative Agent;

(e) within 90 days (or such later date as the Administrative Agent may agree in its reasonable discretion) after the beginning of each fiscal year (commencing with the fiscal year ending December 31, 2019), a consolidated annual budget for such fiscal year consisting of a projected consolidated balance sheet of the Borrower and its Subsidiaries as of the end of the following fiscal year and the related consolidated statements of projected cash flow and projected income (collectively, the "Budget"), which Budget shall in each case be accompanied by the statement of a Financial Officer of the Borrower to the effect that the Budget is based on assumptions believed by the Borrower to be reasonable as of the date of delivery thereof;

(f) upon the reasonable request of the Administrative Agent not more frequently than once a year, an updated Perfection Certificate (or, to the extent such request relates to specified information contained in the Perfection Certificate, such information) reflecting all changes since the date of the information most recently received pursuant to this clause (f) or Section 5.10(f);

(g) promptly, from time to time, such other information regarding the operations, business affairs and financial condition of Holdings, the Borrower or any of the Subsidiaries, or compliance with the terms of any Loan Document as in each case the Administrative Agent may reasonably request (for itself or on behalf of any Lender);

(h) in the event that Holdings or any Parent Entity reports on a consolidated basis, such consolidated reporting at Holdings or such Parent Entity's level in a manner consistent with that described in clauses (a) and (b) of this Section 5.04 for the Borrower (together with a reconciliation showing the adjustments necessary to determine compliance by the Borrower and its Subsidiaries with the Financial Covenant) will satisfy the requirements of such paragraphs;

(i) following the occurrence and during the continuance of a Reporting Triggering Event, monthly inventory reports, summaries of receivables and payables and information concerning aging of receivables and payables, as applicable, in each case in scope and format consistent with the Borrower's systems as determined by the Borrower and the Administrative Agent in its Reasonable Credit Judgment; provided, however, that the foregoing

information with respect to any business or assets acquired by a Loan Party after the Closing Date may be of a different scope and/or in a different format as determined by the Borrower and the Administrative Agent in its Reasonable Credit Judgment prior to the time such acquired business or asset is integrated into the Borrower's systems; and

(j) on or before the fifteenth Business Day following the end of each month, commencing with the first full month beginning after the Initial Borrowing Base Certificate Date, a Borrowing Base Certificate from the Borrower as of the last day of such immediately preceding month, with such customary supporting information as the Administrative Agent may reasonably request. Notwithstanding the foregoing, after the occurrence and during the continuance of a Reporting Triggering Event, the Borrower shall, if requested by the Administrative Agent, execute and deliver to the Administrative Agent Borrowing Base Certificates weekly on or before the fifth Business Day following the end of the week. The Borrower may, at its option, deliver Borrowing Base Certificates more frequently than required by the foregoing provisions of this Section 5.04(j). The Borrower shall provide the Administrative Agent and its advisors and consultants with access and information relating to the Borrower, the Subsidiary Loan Parties and their respective assets that is sufficient in the Borrower's good faith determination for the Administrative Agent and its advisors and consultants to complete, no later than the Startup Date and at the expense of the Borrower, a customary field examination and inventory appraisal, which shall be in addition to the Collateral Audits and appraisals permitted under Section 5.07. The Borrower shall deliver the initial Borrowing Base Certificate no later than the Startup Date; provided, that the Borrower shall not be required to deliver (but may in its discretion elect to deliver) the initial Borrowing Base Certificate before the Startup Date.

The Borrower hereby acknowledges and agrees that all financial statements furnished pursuant to paragraphs (a), (b) and (d) above are hereby deemed to be Borrower Materials suitable for distribution, and to be made available, to Public Lenders as contemplated by Section 9.17 and may be treated by the Administrative Agent and the Lenders as if the same had been marked "PUBLIC" in accordance with such paragraph (unless the Borrower otherwise notifies the Administrative Agent in writing on or prior to delivery thereof).

Section 5.05 Litigation and Other Notices. Furnish to the Administrative Agent (which will promptly thereafter furnish to the Lenders) written notice of the following promptly after any Responsible Officer of Holdings (prior to a Qualified IPO) or the Borrower obtains actual knowledge thereof:

(a) any Event of Default or Default, specifying the nature and extent thereof and the corrective action (if any) proposed to be taken with respect thereto;

(b) the filing or commencement of, or any written threat or notice of intention of any person to file or commence, any action, suit or proceeding, whether at law or in equity or by or before any Governmental Authority or in arbitration, against Holdings, the Borrower or any of the Subsidiaries as to which an adverse determination is reasonably probable and which, if adversely determined, would reasonably be expected to have a Material Adverse Effect;



(c) any other development specific to Holdings, the Borrower or any of the Subsidiaries that is not a matter of general public knowledge and that has had, or would reasonably be expected to have, a Material Adverse Effect; and

(d) the occurrence of any ERISA Event that, together with all other ERISA Events that have occurred, would reasonably be expected to have a Material Adverse Effect.

Section 5.06 Compliance with Laws. Comply with all laws, rules, regulations and orders of any Governmental Authority applicable to it or its property, except where the failure to do so, individually or in the aggregate, would not reasonably be expected to result in a Material Adverse Effect; provided, that this Section 5.06 shall not apply to Environmental Laws, which are the subject of Section 5.09, or to laws related to Taxes, which are the subject of Section 5.03.

Section 5.07 Maintaining Records; Access to Properties and Inspections; Collateral Audits; Appraisals. (a) Maintain all financial records in accordance with GAAP and permit any persons designated by the Administrative Agent or, upon the occurrence and during the continuance of an Event of Default, any Lender (at such Lender's expense) to visit and inspect (other than in connection with a Collateral Audit or an appraisal pursuant to clauses (b) and (c) of this Section 5.07, respectively) the financial records and the properties of Holdings (prior to a Qualified IPO), the Borrower or any of the Subsidiaries at reasonable times, upon reasonable prior notice to Holdings (prior to a Qualified IPO) or the Borrower and as often as reasonably requested and to make extracts from and copies of such financial records, and permit any persons designated by the Administrative Agent or, upon the occurrence and during the continuance of an Event of Default, any Lender (at such Lender's expense) upon reasonable prior notice to Holdings (prior to a Qualified IPO), the Borrower to discuss the affairs, finances and condition of Holdings (prior to a Qualified IPO), the Borrower or any of the Subsidiaries, with the officers thereof and independent accountants therefor (so long as the Borrower has the opportunity to participate in any such discussions with such accountants), in each case, subject to reasonable requirements of confidentiality, including requirements imposed by law or by contract. The visitation and inspection rights of the Administrative Agent and its designees, including in connection with any Collateral Audit or appraisal, shall be subject to at least five (5) Business Days' prior notice (or, if an Event of Default or Appraisal Triggering Event has occurred and is continuing, at least one Business Day's prior notice) and shall be at such reasonable times, during normal business hours and without undue disruption to the business of Holdings, the Borrower or any of the Subsidiaries.

(b) If no Appraisal Triggering Event or an Event of Default has occurred and is continuing during any twelve-month period, the Administrative Agent (either by itself or by a third-party consultant reasonably satisfactory to the Administrative Agent and the Borrower) shall not conduct more than one Collateral Audit during such twelve-month period (or, during the first consecutive twelve-month period after the Closing Date, not more than two Collateral Audits). If an Appraisal Triggering Event has occurred and is continuing during any twelve-month period, the Administrative Agent (either by itself or by a third party consultant reasonably satisfactory to the Administrative Agent and the Borrower) may conduct one

additional Collateral Audit during such twelve-month period. If an Event of Default has occurred and is continuing, the Administrative Agent (either by itself or by a third-party consultant reasonably satisfactory to the Administrative Agent and the Borrower) may conduct Collateral Audits as are deemed reasonably necessary by the Administrative Agent without limitation on the number thereof or otherwise counting against the number of Collateral Audits that may be conducted under this clause (b). Any Collateral Audit conducted at the request of the Borrower in connection with a Material Increase Acquisition shall count as a Collateral Audit for purposes of the preceding sentence if such Collateral Audit is not primarily limited in scope to the assets acquired in such Material Increase Acquisition. The Borrower agrees to reimburse the Administrative Agent for its actual and documented out-of-pocket costs and expenses reasonably incurred in connection with the Collateral Audits referred to in this clause (b).

(c) If no Appraisal Triggering Event or Event of Default has occurred and is continuing in any twelve-month period, the Borrower shall provide to the Administrative Agent, upon request of the Administrative Agent and at the expense of the Borrower, during such twelve-month period, one appraisal or update thereof of any or all of the inventory Collateral from one or more Acceptable Appraisers, and prepared in a form and on a basis reasonably satisfactory to the Administrative Agent, which appraisal and/or update shall include information required by applicable law and by the internal policies of the Lenders; provided, that if an Appraisal Triggering Event has occurred and is continuing during any twelve-month period, the Administrative Agent shall be entitled to receive up to two such appraisals or updates during such twelve-month period. If an Event of Default has occurred and is continuing, the Administrative Agent shall be entitled to receive such appraisals or updates as are deemed reasonably necessary by the Administrative Agent without limitation on the number thereof or otherwise counting against the number of appraisals or updates that may be conducted under this clause (c). Any appraisals or updates conducted at the request of the Borrower in connection with a Material Increase Acquisition shall count as appraisals or updates for purposes of the preceding sentence if such appraisals or updates are not primarily limited in scope to the assets acquired in such Material Increase Acquisition. In addition, the Loan Parties shall have the right (but not the obligation), at their expense, at any time and from time to time to provide the Administrative Agent with additional appraisals or updates thereof of any or all of the inventory Collateral from one or more Acceptable Appraisers selected and engaged by the Administrative Agent, and prepared in a form and on a basis reasonably satisfactory to the Administrative Agent, in which case such appraisals or updates shall be used in connection with the calculation of the Borrowing Base hereunder. With respect to each appraisal made pursuant to this Section 5.07(c), (i) the Administrative Agent and the Loan Parties shall each be given a reasonable amount of time to review and comment on a draft form of the appraisal prior to its finalization and (ii) any adjustments to the Borrowing Base hereunder as a result of such appraisal shall become effective upon the twentieth (20<sup>th</sup>) day following the finalization of such appraisal (except to the extent otherwise provided in the fourth paragraph of the definition of "Borrowing Base" with respect to Material Increase Acquisitions).

Section 5.08 Use of Proceeds. Use the proceeds of the Loans made and Letters of Credit issued in the manner contemplated by Section 3.12.

Section 5.09 Compliance with Environmental Laws. Comply, and make reasonable efforts to cause all lessees and other persons occupying its properties to comply, with all Environmental Laws applicable to its operations and properties; and obtain and renew all material authorizations and permits required pursuant to Environmental Law for its operations and properties, in each case in accordance with Environmental Laws, except, in each case with respect to this Section 5.09, to the extent the failure to do so would not reasonably be expected to have, individually or in the aggregate, a Material Adverse Effect.

Section 5.10 Further Assurances; Additional Security.

(a) Execute any and all further documents, financing statements, agreements and instruments, and take all such further actions (including the filing and recording of financing statements, fixture filings, Mortgages and other documents) that the Collateral Agent may reasonably request (including, without limitation, those required by applicable law), to satisfy the Collateral and Guarantee Requirement and to cause the Collateral and Guarantee Requirement to be and remain satisfied, all at the expense of the Loan Parties and provide to the Collateral Agent, from time to time upon reasonable request, evidence reasonably satisfactory to the Collateral Agent as to the perfection and priority of the Liens created or intended to be created by the Security Documents.

(b) If any asset (other than Real Property) that has an individual fair market value (as determined in good faith by the Borrower) in an amount greater than \$5,000,000 is acquired by the Borrower or any Subsidiary Loan Party after the Closing Date or owned by an entity at the time it becomes a Subsidiary Loan Party (in each case other than (x) assets constituting Collateral under a Security Document that become subject to the Lien of such Security Document upon acquisition thereof and (y) assets constituting Excluded Property), the Borrower or such Subsidiary Loan Party, as applicable, will (i) notify the Collateral Agent of such acquisition or ownership and (ii) cause such asset to be subjected to a Lien (subject to any Permitted Liens) securing the Obligations, and take, and cause the Subsidiary Loan Parties to take, such actions as shall be reasonably requested by the Collateral Agent to grant and perfect such Liens, including actions described in clause (a) of this Section 5.10, all at the expense of the Loan Parties, subject to clause (g) below.

(c) (i) Grant and cause each of the Subsidiary Loan Parties to grant to the Collateral Agent security interests in, and mortgages on, any Material Real Property of the Borrower or such Subsidiary Loan Parties, as applicable, that are not Mortgaged Property as of the Closing Date, to the extent acquired after the Closing Date, within 90 days after such acquisition (or such later date as the Collateral Agent may agree in its reasonable discretion) pursuant to documentation in such other form as is reasonably satisfactory to the Collateral Agent and the Borrower (each, an "Additional Mortgage"), which security interest and mortgage shall constitute valid and enforceable Liens subject to no other Liens except Permitted Liens, at the time of recordation thereof, (ii) record or file, and cause each such Subsidiary to record or file, the Additional Mortgage or instruments related thereto in such manner and in such places as is required by law to establish, preserve and protect the Liens in favor of the Collateral Agent (for the benefit of the Secured Parties) required to be granted pursuant to the Additional Mortgages and pay, and cause each such Subsidiary to pay, in full, all Taxes, fees and other

charges required to be paid in connection with such recording or filing, in each case subject to clause (g) below, and (iii) deliver to the Collateral Agent an updated Schedule 1.01(B) reflecting such additional Mortgaged Properties. Unless otherwise waived by the Collateral Agent, with respect to each such Additional Mortgage, the Borrower shall cause the requirements set forth in clauses (f) and (g) of the definition of “Collateral and Guarantee Requirement” to be satisfied with respect to such Material Real Property.

(d) If any additional direct or indirect Subsidiary of the Borrower is formed or acquired after the Closing Date (with any Subsidiary Redesignation resulting in an Unrestricted Subsidiary becoming a Subsidiary being deemed to constitute the acquisition of a Subsidiary) and if such Subsidiary is a Subsidiary Loan Party, within 15 Business Days after the date such Subsidiary is formed or acquired (or such longer period as the Collateral Agent shall agree in its reasonable discretion), notify the Collateral Agent thereof and, within 20 Business Days after the date such Subsidiary is formed or acquired or such longer period as the Collateral Agent shall agree in its reasonable discretion (or, with respect to clauses (f), (g) and (h) of the definition of “Collateral and Guarantee Requirement”, within 90 days after such formation or acquisition or such longer period as set forth therein or as the Collateral Agent may agree in its reasonable discretion, as applicable), cause the Collateral and Guarantee Requirement to be satisfied with respect to such Subsidiary and with respect to any Equity Interest in or Indebtedness of such Subsidiary owned by or on behalf of any Loan Party, subject to clause (g) below.

(e) If any additional Foreign Subsidiary of the Borrower is formed or acquired after the Closing Date (with any Subsidiary Redesignation resulting in an Unrestricted Subsidiary becoming a Subsidiary being deemed to constitute the acquisition of a Subsidiary) and if such Subsidiary is a “first tier” Foreign Subsidiary of a Loan Party, within 15 Business Days after the date such Foreign Subsidiary is formed or acquired (or such longer period as the Collateral Agent may agree in its reasonable discretion), notify the Collateral Agent thereof and, within 50 Business Days after the date such Foreign Subsidiary is formed or acquired or such longer period as the Collateral Agent shall agree in its reasonable discretion, cause the Collateral and Guarantee Requirement to be satisfied with respect to any Equity Interest in such Foreign Subsidiary owned by or on behalf of any Loan Party, subject to clause (g) below.

(f) Furnish to the Collateral Agent prompt written notice of any change (A) in any Loan Party’s corporate or organization name, (B) in any Loan Party’s identity or organizational structure, (C) in any Loan Party’s organizational identification number, (D) in any Loan Party’s jurisdiction of organization or (E) in the location of the chief executive office of any Loan Party that is not a registered organization; provided, that the Borrower shall not effect or permit any such change unless all filings have been made, or will have been made within 30 days following such change (or such longer period as the Collateral Agent may agree in its reasonable discretion), under the Uniform Commercial Code that are required in order for the Collateral Agent to continue at all times following such change to have a valid, legal and perfected security interest in all the Collateral in which a security interest may be perfected by such filing, for the benefit of the Secured Parties.

(g) The Collateral and Guarantee Requirement and the other provisions of this Section 5.10 and the other Loan Documents with respect to the Collateral need not be satisfied with respect to any of the following (collectively, the “Excluded Property”): (i) any Real Property other than Material Real Property, (ii) motor vehicles and other assets subject to certificates of title (except to the extent constituting Eligible Equipment; provided that, security interest perfection actions beyond the filing of UCC-1 financing statements shall only be required with respect to Titled Equipment to the extent having an aggregate Net Book Value in excess of \$2,500,000) and letter of credit rights (in each case, other than to the extent a Lien on such assets or such rights can be perfected by filing a UCC-1) and commercial tort claims with a value of less than \$5,000,000, (iii) pledges and security interests prohibited by applicable law, rule, regulation or contractual obligation not in violation of Section 6.09(c) (in each case, except to the extent such prohibition is unenforceable after giving effect to the applicable anti-assignment provisions of Article 9 of the Uniform Commercial Code), (iv) assets to the extent a security interest in such assets could reasonably be expected to result in material adverse tax consequences as determined in good faith by the Borrower, (v) any lease, license or other agreement to the extent that a grant of a security interest therein would violate or invalidate such lease, license or agreement or create a right of termination in favor of any other party thereto (other than Holdings, the Borrower or any Subsidiary Guarantor) after giving effect to the applicable anti-assignment provisions of Article 9 of the Uniform Commercial Code, (vi) those assets as to which the Collateral Agent and the Borrower reasonably agree that the cost or other consequence of obtaining such a security interest or perfection thereof are excessive in relation to the value afforded thereby, (vii) any governmental licenses or state or local franchises, charters and authorizations, to the extent security interests in such licenses, franchises, charters or authorizations are prohibited or restricted thereby after giving effect to the applicable anti-assignment provisions of Article 9 of the Uniform Commercial Code, (viii) any “intent-to-use” applications for trademark or service mark registrations filed pursuant to Section 1(b) of the Lanham Act, 15 U.S.C. §1051, unless and until an Amendment to Allege Use or a Statement of Use under Section 1(c) or 1(d) of the Lanham Act has been filed with the United States Patent and Trademark Office, (x) any Excluded Securities, (xi) any Excluded Deposit Accounts (xii) any Third Party Funds, (xiii) any equipment or other asset that is subject to a Lien permitted by any of clauses (c), (i), (j) or (ii) of Section 6.02 or is otherwise subject to a purchase money debt or a Capitalized Lease Obligation, in each case, as permitted by Section 6.01, if the contract or other agreement providing for such debt or Capitalized Lease Obligation prohibits or requires the consent of any person (other than the Borrower or any Guarantor) as a condition to the creation of any other security interest on such equipment or asset and, in each case, such prohibition or requirement is permitted hereunder (after giving effect to the applicable anti-assignment provisions of Article 9 of the Uniform Commercial Code or other applicable law), (xiv) all assets of Holdings other than, prior to a Qualified IPO, Equity Interests of the Borrower directly held by Holdings and pledged pursuant to the Holdings Guarantee and Pledge Agreement, (xv) aircrafts and (xvi) any other exceptions mutually agreed upon between the Borrower and the Collateral Agent; provided, that the Borrower may in its sole discretion elect to exclude any property from the definition of Excluded Property. Notwithstanding anything herein to the contrary, (A) the Collateral Agent may grant extensions of time or waivers of requirements for the creation or perfection of security interests in or the obtaining of insurance (including title insurance) or surveys with respect to particular assets (including extensions beyond the Closing Date for the perfection of security interests in the assets of the Loan Parties on such date) where

it reasonably determines, in consultation with the Borrower, that perfection or obtaining of such items cannot be accomplished by the time or times at which it would otherwise be required by this Agreement or the other Loan Documents, (B) except as required by Section 5.11, no control, lockbox or similar agreement or arrangement shall be required with respect to any deposit accounts, securities accounts or commodities accounts, (C) no foreign law governed security documents shall be required, (D) Liens required to be granted from time to time pursuant to, or any other requirements of, the Collateral and Guarantee Requirement and the Security Documents shall be subject to exceptions and limitations set forth in the Security Documents, (E) no notices shall be required to be sent to account debtors or other contractual third parties prior to the occurrence and during the continuance of an Event of Default, and (F) to the extent any Mortgaged Property is located in a jurisdiction with mortgage recording or similar tax, the amount secured by the Security Document with respect to such Mortgaged Property shall be limited to the fair market value of such Mortgaged Property as determined in good faith by the Borrower (subject to any applicable laws in the relevant jurisdiction) or such lesser amount reasonably agreed to by the Collateral Agent.

(h) If any person becomes a Loan Party after the Closing Date (whether by acquisition, formation or otherwise), such person shall comply with the provisions of Section 5.11, including, within 90 days after the date on which such Subsidiary is formed or acquired or such longer period as the Collateral Agent shall agree in its reasonable discretion, by entering into Account Control Agreements with the Collateral Agent and any bank or other financial institution with which such Loan Party maintains (i) primary concentration accounts or (ii) such other accounts that do not qualify as Exempted Accounts, in respect of each such account; provided, that no such Account Control Agreement shall be required before the date that is 150 days after the Closing Date.

#### Section 5.11 Cash Management Systems; Application of Proceeds of Accounts.

(a) Within 150 days after the Closing Date (or such later day as the Administrative Agent may reasonably agree), each Loan Party shall enter into a customary account control agreement, in a form reasonably satisfactory to the Administrative Agent (each, an “Account Control Agreement”) with the Collateral Agent and any bank or other financial institution with which such Loan Party maintains (x) primary concentration accounts or (y) such other accounts that exist on the Closing Date and do not qualify as Exempted Accounts, in respect of each such account. In addition, each applicable Loan Party shall enter into an Account Control Agreement with respect to any new account that does not qualify as, or any account that ceases to be, an Exempted Account, in each case within 90 days (or such longer period as the Administrative Agent may reasonably agree) after such account is established or ceases to be an Exempted Account, as applicable; provided, that no such Account Control Agreement shall be required before the date that is 150 days after the Closing Date.

(b) At any time after the occurrence and during the continuance of a Cash Dominion Triggering Event, the Administrative Agent shall have the right to deliver a Notice of Sole Control (or similar term, as defined in each Account Control Agreement) with respect to each Controlled Account and to transfer or cause to be transferred, no less frequently than once per Business Day (unless the Termination Date has occurred), all available cash

balances and cash receipts, including the then contents or then entire ledger balance of each Controlled Account net of such minimum balance (not to exceed (i) in the case of any primary concentration account, \$100,000 individually and \$500,000 in the aggregate and (ii) in the case of any other Controlled Account, \$75,000 individually and \$250,000 in the aggregate), if any, to an account of, and maintained by, the Collateral Agent in the name of the Borrower (the "Collateral Agent Account"). Subject to the terms of the Collateral Agreement and, if applicable, Section 2.18(b), all amounts received in the Collateral Agent Account shall be distributed and applied on a daily basis by the Administrative Agent to repay outstanding Loans and, if an Event of Default has occurred and is continuing, to Cash Collateralize any Revolving L/C Exposure in respect of outstanding Letters of Credit in accordance with Section 2.05(j); provided, that, for the avoidance of doubt, any repayment or prepayment of the Revolving Loans pursuant to this sentence shall not reduce the Revolving Commitments then in effect.

(c) The Collateral Agent Account shall at all times be under the sole dominion and control of the Collateral Agent. The funds on deposit in the Collateral Agent Account shall be applied in accordance with this Agreement and any Permitted Intercreditor Agreement, if applicable.

(d) The Loan Parties may close and/or open any account (including any Controlled Account) maintained at any bank or other financial institution subject to the applicable requirements of Section 5.11(a).

(e) So long as no Cash Dominion Triggering Event has occurred and is continuing, the Loan Parties shall have full and complete access to, and may direct, and shall have sole control over, the manner of disposition of funds in all Controlled Accounts.

(f) At any time after the occurrence and during the continuance of a Cash Dominion Triggering Event, (i) any cash or cash equivalents owned by any Loan Party (other than (x) an amount not to exceed \$2,000,000 in the aggregate that is on deposit in a segregated account which the Borrower designates in writing to the Administrative Agent as being the "uncontrolled cash account" (the "Designated Disbursement Account"), (y) de minimis cash or cash equivalents from time to time inadvertently misapplied by any Loan Party and (z) cash or cash equivalents in any Excluded Deposit Accounts) that are deposited to any account, or held or invested in any manner, otherwise than in a Controlled Account, such cash or cash equivalents shall be transferred to a Controlled Account no less frequently than once per Business Day and (ii) no funds on deposit in the Designated Disbursement Account shall be used for any purpose other than (A) general corporate purposes, including the payment of trade payables and operating expenses incurred by the Loan Parties in the ordinary course of business (including any debt service payment due in respect of any Indebtedness of the Loan Parties otherwise permitted hereunder) and (B) up to \$500,000 for such other purposes permitted hereunder as the Loan Parties may deem appropriate.

(g) The Administrative Agent shall promptly (but in any event within one (1) Business Day of obtaining knowledge thereof) (a) furnish written notice to each person with whom a Controlled Account is maintained of any termination of a Cash Dominion Triggering Event or (b) take such other action and execute such other documents as may be reasonably requested by the Borrower or the applicable Loan Party in connection with any termination of a Cash Dominion Triggering Event.

(h) Notwithstanding anything herein to the contrary, it is understood and agreed that no blocked account or other control agreements shall be required with respect to (a) any disbursement or payroll accounts used solely for such purposes, (b) any Excluded Deposit Accounts, (c) the Designated Disbursement Account or (d) any other accounts (including deposit accounts) with an average monthly balance of less than \$500,000 individually or \$1,000,000 in the aggregate (any such excluded accounts in this clause (g), the "Exempted Accounts").

(i) Any amounts held or received in the Collateral Agent Account (including all interest and other earnings with respect thereto, if any) (x) upon the occurrence of the Termination Date or (y) when no Cash Dominion Triggering Event exists, shall (subject in the case of subclause (x) to the provisions of any Permitted Intercreditor Agreement, if applicable) be remitted to an account of the Borrower designated by the Borrower to the Administrative Agent.

Section 5.12 Post-Closing. Take all necessary actions to satisfy the items described on Schedule 5.10 within the applicable period of time specified in such Schedule (or such longer period as the Administrative Agent may agree in its reasonable discretion).

## ARTICLE VI

### *Negative Covenants*

The Borrower covenants and agrees with each Lender that, from and after the Closing Date and until the Termination Date, unless the Required Lenders shall otherwise consent in writing, the Borrower will not, and will not permit any of the Subsidiaries to:

Section 6.01 Indebtedness. Incur, create, assume or permit to exist any Indebtedness, except:

(a) Indebtedness existing on the Closing Date (provided, that any such Indebtedness that is (x) not intercompany Indebtedness and (y) in excess of \$1,000,000 shall be set forth on Schedule 6.01) and any Permitted Refinancing Indebtedness incurred to Refinance such Indebtedness (other than intercompany Indebtedness Refinanced with Indebtedness owed to a person not affiliated with the Borrower or any Subsidiary);

(b) Indebtedness created hereunder (including pursuant to Section 2.21) and under the other Loan Documents and any Permitted Refinancing Indebtedness incurred to Refinance such Indebtedness;

(c) Indebtedness of the Borrower or any Subsidiary pursuant to Hedging Agreements entered into for non-speculative purposes;



(d) Indebtedness owed to (including obligations in respect of letters of credit or bank guarantees or similar instruments for the benefit of) any person providing workers' compensation, health, disability or other employee benefits or property, casualty or liability insurance to the Borrower or any Subsidiary, pursuant to reimbursement or indemnification obligations to such person, in each case in the ordinary course of business or consistent with past practice or industry practices;

(e) Indebtedness of the Borrower to Holdings or any Subsidiary and of any Subsidiary to Holdings, the Borrower or any other Subsidiary; provided, that (i) Indebtedness of any Subsidiary that is not a Subsidiary Loan Party owing to the Loan Parties shall be subject to Section 6.04(b) and (ii) Indebtedness owed by any Loan Party to any Subsidiary that is not a Loan Party shall be subordinated to the Loan Obligations under this Agreement on subordination terms described in the intercompany note substantially in the form of Exhibit K hereto or on other subordination terms reasonably satisfactory to the Administrative Agent and the Borrower;

(f) Indebtedness in respect of performance bonds, bid bonds, appeal bonds, surety bonds and completion guarantees and similar obligations, in each case provided in the ordinary course of business or consistent with past practice or industry practices, including those incurred to secure health, safety and environmental obligations in the ordinary course of business or consistent with past practice or industry practices;

(g) Indebtedness arising from the honoring by a bank or other financial institution of a check, draft or similar instrument drawn against insufficient funds in the ordinary course of business or other cash management services, in each case incurred in the ordinary course of business;

(h) [Reserved];

(i) (i) Capitalized Lease Obligations and mortgage financings incurred by the Borrower or any Subsidiary prior to or within 270 days after the acquisition, lease, construction, repair, replacement or improvement of the respective property (real or personal, and whether through the direct purchase of property or the Equity Interest of any person owning such property) permitted under this Agreement in order to finance such acquisition, lease, construction, repair, replacement or improvement, in an aggregate principal amount that at the time of, and after giving effect to, the incurrence thereof, together with the aggregate amount of any other Indebtedness outstanding pursuant to this Section 6.01(i), would not exceed the greater of \$5,000,000 and 0.046 times EBITDAR calculated on a Pro Forma Basis for the then most recently ended Test Period and (ii) any Permitted Refinancing Indebtedness in respect thereof;

(j) Capitalized Lease Obligations incurred by the Borrower or any Subsidiary in respect of any Sale and Lease-Back Transaction that is permitted under Section 6.03 and any Permitted Refinancing Indebtedness in respect thereof;

(k) [Reserved];

(l) [Reserved];

(m) Guarantees (i) by Holdings, the Borrower or any Subsidiary Loan Party of any Indebtedness of the Borrower or any Subsidiary Loan Party permitted to be incurred under this Agreement, (ii) by the Borrower or any Subsidiary Loan Party of Indebtedness otherwise permitted hereunder of any Subsidiary that is not a Subsidiary Loan Party to the extent such Guarantees are permitted by Section 6.04 (other than Section 6.04(v)), (iii) by any Subsidiary that is not a Subsidiary Loan Party of Indebtedness of another Subsidiary that is not a Subsidiary Loan Party, and (iv) by the Borrower of Indebtedness of Subsidiaries that are not Subsidiary Loan Parties incurred for working capital purposes in the ordinary course of business on ordinary business terms so long as such Indebtedness is permitted to be incurred hereunder to the extent such Guarantees are permitted by Section 6.04 (other than Section 6.04(v)); provided, that Guarantees by the Borrower or any Subsidiary Loan Party under this Section 6.01(m) of any other Indebtedness of a person that is subordinated to other Indebtedness of such person shall be expressly subordinated to the Loan Obligations under this Agreement to at least the same extent as such underlying Indebtedness is subordinated;

(n) Indebtedness arising from agreements of the Borrower or any Subsidiary providing for indemnification, adjustment of purchase or acquisition price or similar obligations (including earn-outs), in each case, incurred or assumed in connection with the Transactions, any Permitted Business Acquisition, other Investments or the disposition of any business, assets or a Subsidiary not prohibited by this Agreement;

(o) Indebtedness in respect of letters of credit, bank guarantees, warehouse receipts or similar instruments issued to support performance obligations and trade letters of credit (other than obligations in respect of other Indebtedness) in the ordinary course of business or consistent with past practice or industry practices;

(p) Indebtedness to finance the acquisition or ownership of aircrafts and aircraft equipment (including airframes, engines, appliances, equipment, instruments or related property), including (x) Capitalized Lease Obligations and (y) transactions through equipment trust certificates or enhanced equipment trust certificates structures;

(q) Indebtedness consisting of (i) the financing of insurance premiums or (ii) take-or-pay obligations contained in supply arrangements, in each case, in the ordinary course of business;

(r) other unsecured Indebtedness or Indebtedness secured by Liens on the Collateral that are junior to, the Liens securing the Loan Obligations in an aggregate principal amount that at the time of, and after giving effect to, the incurrence thereof, together with the aggregate amount of any other Indebtedness outstanding pursuant to this Section 6.01(r), would not exceed \$10,000,000, and any Permitted Refinancing Indebtedness in respect thereof;

(s) [Reserved];

(t) [Reserved];

(u) Indebtedness incurred in the ordinary course of business in respect of obligations of the Borrower or any Subsidiary to pay the deferred purchase price of goods or services or progress payments in connection with such goods and services; provided, that such obligations are incurred in connection with open accounts extended by suppliers on customary trade terms in the ordinary course of business and not in connection with the borrowing of money or any Hedging Agreements;

(v) Indebtedness representing deferred compensation to employees, consultants or independent contractors of the Borrower (or, to the extent such work is done for the Borrower or the Subsidiaries, any direct or indirect parent thereof) or any Subsidiary incurred in the ordinary course of business;

(w) obligations in respect of Cash Management Agreements;

(x) [Reserved];

(y) [Reserved];

(z) [Reserved];

(aa) Indebtedness incurred on behalf of, or representing Guarantees of Indebtedness of, joint ventures that at the time of, and after giving effect to, the incurrence thereof, together with the aggregate amount of any other Indebtedness outstanding pursuant to this Section 6.01(aa), would not exceed the greater of \$5,000,000 and 0.046 times EBITDAR calculated on a Pro Forma Basis for the then most recently ended Test Period, and any Permitted Refinancing Indebtedness in respect thereof;

(bb) Indebtedness issued by the Borrower or any Subsidiary to current or former officers, directors and employees, their respective estates, spouses or former spouses to finance the purchase or redemption of Equity Interests of Holdings or any Parent Entity permitted by Section 6.06;

(cc) Indebtedness consisting of obligations of the Borrower or any Subsidiary under deferred compensation or other similar arrangements incurred by such person in connection with the Transactions and Permitted Business Acquisitions or any other Investment permitted hereunder;

(dd) Indebtedness of the Borrower or any Subsidiary to or on behalf of any joint venture (regardless of the form of legal entity) that is not a Subsidiary arising in the ordinary course of business in connection with the cash management operations (including with respect to intercompany self-insurance arrangements) of the Borrower and the Subsidiaries;

(ee) [Reserved];

(ff) [Reserved]; and

(gg) all premium (if any, including tender premiums) expenses, defeasance costs, interest (including post-petition interest), fees, expenses, charges and additional or contingent interest on obligations described in clauses (a) through (ff) above or refinancings thereof.

For purposes of determining compliance with this Section 6.01, the amount of any Indebtedness denominated in any currency other than Dollars shall be calculated based on customary currency exchange rates in effect, in the case of such Indebtedness incurred (in respect of term Indebtedness) or committed (in respect of revolving Indebtedness) on or prior to the Closing Date, on the Closing Date and, in the case of such Indebtedness incurred (in respect of term Indebtedness) or committed (in respect of revolving Indebtedness) after the Closing Date, on the date on which such Indebtedness was incurred (in respect of term Indebtedness) or committed (in respect of revolving Indebtedness); provided, that if such Indebtedness is incurred to refinance other Indebtedness denominated in a currency other than Dollars (or in a different currency from the Indebtedness being refinanced), and such refinancing would cause the applicable Dollar-denominated restriction to be exceeded if calculated at the relevant currency exchange rate in effect on the date of such refinancing, such Dollar-denominated restriction shall be deemed not to have been exceeded so long as the principal amount of such refinancing Indebtedness does not exceed (i) the outstanding or committed principal amount, as applicable, of such Indebtedness being refinanced plus (ii) the aggregate amount of fees, underwriting discounts, premiums (including tender premiums), defeasance costs and other costs and expenses incurred in connection with such refinancing.

Further, for purposes of determining compliance with this Section 6.01, (A) Indebtedness need not be permitted solely by reference to one category of permitted Indebtedness described in Sections 6.01(a) through (gg) but may be permitted in part under any combination thereof and (B) in the event that an item of Indebtedness (or any portion thereof) meets the criteria of one or more of the categories of permitted Indebtedness described in Sections 6.01(a) through (gg), the Borrower shall, in its sole discretion, classify or reclassify, or later divide, classify or reclassify, such item of Indebtedness (or any portion thereof) in any manner that complies with this Section 6.01 and will only be required to include the amount and type of such item of Indebtedness (or any portion thereof) in one of the above clauses and such item of Indebtedness shall be treated as having been incurred or existing pursuant to only one of such clauses; provided, that (i) all Indebtedness under outstanding on the Closing Date under this Agreement shall at all times be deemed to have been incurred pursuant to clause (p)(i) of this Section 6.01. In addition, with respect to any Indebtedness that was permitted to be incurred hereunder on the date of such incurrence, any Increased Amount of such Indebtedness shall also be permitted hereunder after the date of such incurrence.

Section 6.02 Liens. Create, incur, assume or permit to exist any Lien on any property or assets (including stock or other securities of any person) of the Borrower or any Subsidiary at the time owned by it or on any income or revenues or rights in respect of any thereof, except the following (collectively, "Permitted Liens"):

(a) Liens on property or assets of the Borrower and the Subsidiaries existing on the Closing Date (or created following the Closing Date pursuant to agreements in existence on the Closing Date requiring the creation of such Liens) and, to the extent securing Indebtedness in an aggregate principal amount in excess of \$1,000,000, set forth on Schedule 6.02(a), and any modifications, replacements, renewals or extensions thereof; provided, that such Liens shall secure only those obligations that they secure on the Closing Date (and any Permitted Refinancing Indebtedness in respect of such obligations permitted by Section 6.01) and shall not subsequently apply to any other property or assets of the Borrower or any Subsidiary other than (A) after-acquired property that is affixed or incorporated into the property covered by such Lien, and (B) proceeds and products thereof;

(b) any Lien created under the Loan Documents (including Liens created under the Security Documents securing obligations in respect of Secured Hedge Agreements and Secured Cash Management Agreements) or permitted in respect of any Mortgaged Property by the terms of the applicable Mortgage;

(c) [Reserved];

(d) Liens for Taxes, assessments or other governmental charges or levies not yet delinquent by more than 30 days or that are being contested in compliance with Section 5.03;

(e) Liens imposed by law, such as landlords', carriers', warehousemen's, mechanics', materialmen's, repairmen's, suppliers', construction or other like Liens securing obligations that are not overdue by more than 30 days or that are being contested in good faith by appropriate proceedings and in respect of which, if applicable, the Borrower or any Subsidiary shall have set aside on its books reserves in accordance with GAAP;

(f) (i) pledges and deposits and other Liens made in the ordinary course of business in compliance with the Federal Employers Liability Act or any other workers' compensation, unemployment insurance and other social security laws or regulations and deposits securing liability to insurance carriers under insurance or self-insurance arrangements in respect of such obligations and (ii) pledges and deposits and other Liens securing liability for reimbursement or indemnification obligations of (including obligations in respect of letters of credit or bank guarantees for the benefit of) insurance carriers providing property, casualty or liability insurance to the Borrower or any Subsidiary;

(g) deposits and other Liens to secure the performance of bids, trade contracts (other than for Indebtedness), leases (other than Capitalized Lease Obligations), statutory obligations, surety and appeal bonds, performance and return of money bonds, bids, leases, government contracts, trade contracts, agreements with utilities, and other obligations of a like nature (including letters of credit in lieu of any such bonds or to support the issuance thereof) incurred in the ordinary course of business, including those incurred to secure health, safety and environmental obligations in the ordinary course of business;

(h) zoning restrictions, easements, survey exceptions, trackage rights, leases (other than Capitalized Lease Obligations), licenses, special assessments, rights-of-way, covenants, conditions, restrictions and declarations on or with respect to the use of Real Property, servicing agreements, development agreements, site plan agreements and other similar encumbrances incurred in the ordinary course of business and title defects or irregularities that are of a minor nature and that, in the aggregate, do not interfere in any material respect with the ordinary conduct of the business of the Borrower or any Subsidiary;

(i) subject to the last paragraph of this Section 6.02, Liens securing Indebtedness permitted by Section 6.01(i); provided, that such Liens do not apply to any property or assets of the Borrower or any Subsidiary other than the property or assets acquired, leased, constructed, replaced, repaired or improved with such Indebtedness (or the Indebtedness Refinanced thereby), and accessions and additions thereto, proceeds and products thereof and customary security deposits; provided, that individual financings provided by one lender may be cross-collateralized to other financings provided by such lender (and its Affiliates);

(j) Liens arising out of capitalized lease transactions permitted under Section 6.03, so long as such Liens attach only to the property sold and being leased in such transaction and any accessions and additions thereto or proceeds and products thereof and related property;

(k) Liens securing judgments that do not constitute an Event of Default under Section 7.01(j);

(l) Liens disclosed by the title insurance policies delivered with respect to the Mortgaged Property set forth on Schedule 1.01(B) as of the Closing Date or subsequent to the Closing Date pursuant to Section 5.10 or Schedule 5.10 and any replacement, extension or renewal of any such Lien; provided, that such replacement, extension or renewal Lien shall not cover any property other than the property that was subject to such Lien prior to such replacement, extension or renewal; provided, further, that the Indebtedness and other obligations secured by such replacement, extension or renewal Lien are permitted by this Agreement;

(m) any interest or title of a lessor or sublessor under any leases or subleases entered into by the Borrower or any Subsidiary in the ordinary course of business;

(n) Liens that are contractual rights of set-off (i) relating to the establishment of depository relations with banks and other financial institutions not given in connection with the issuance of Indebtedness, (ii) relating to pooled deposits, sweep accounts, reserve accounts or similar accounts of the Borrower or any Subsidiary to permit satisfaction of overdraft or similar obligations incurred in the ordinary course of business of the Borrower or any Subsidiary, including with respect to credit card charge-backs and similar obligations, or (iii) relating to purchase orders and other agreements entered into with customers, suppliers or service providers of the Borrower or any Subsidiary in the ordinary course of business;

(o) Liens (i) arising solely by virtue of any statutory or common law provision relating to banker's liens, rights of set-off or similar rights, (ii) attaching to commodity trading accounts or other commodity brokerage accounts incurred in the ordinary course of business, (iii) encumbering reasonable customary initial deposits and margin deposits and similar Liens attaching to brokerage accounts incurred in the ordinary course of business and not for speculative purposes, (iv) in respect of Third Party Funds or (v) in favor of credit card companies pursuant to agreements therewith;

(p) Liens securing obligations in respect of trade-related letters of credit, bankers' acceptances or similar obligations permitted under Section 6.01(f), (k) or (o) and covering the property (or the documents of title in respect of such property) financed by such letters of credit, bankers' acceptances or similar obligations and the proceeds and products thereof;

(q) leases or subleases, licenses or sublicenses (including with respect to Intellectual Property) granted to others in the ordinary course of business not interfering in any material respect with the business of the Borrower and the Subsidiaries, taken as a whole;

(r) Liens in favor of customs and revenue authorities arising as a matter of law to secure payment of customs duties in connection with the importation of goods;

(s) Liens solely on any cash earnest money deposits made by the Borrower or any of the Subsidiaries in connection with any letter of intent or purchase agreement in respect of any Investment permitted hereunder;

(t) (i) Liens with respect to property or assets of any Subsidiary that is not a Loan Party securing obligations of a Subsidiary that is not a Loan Party permitted under Section 6.01 and (ii) subject to the last paragraph of this Section 6.02, Liens with respect to property or assets of any person securing Indebtedness permitted under Section 6.01(aa);

(u) Liens on any amounts held by a trustee under any indenture or other debt agreement issued in escrow pursuant to customary escrow arrangements pending the release thereof, or under any indenture or other debt agreement pursuant to customary discharge, redemption or defeasance provisions;

(v) the prior rights of consignees and their lenders under consignment arrangements entered into in the ordinary course of business;

(w) agreements to subordinate any interest of the Borrower or any Subsidiary in any accounts receivable or other proceeds arising from inventory consigned by the Borrower or any of their Subsidiaries pursuant to an agreement entered into in the ordinary course of business;

(x) Liens arising from precautionary Uniform Commercial Code financing statements regarding operating leases or other obligations not constituting Indebtedness;

(y) Liens on Equity Interests in joint ventures (i) securing obligations of such joint venture or (ii) pursuant to the relevant joint venture agreement or arrangement;

(z) Liens on securities that are the subject of repurchase agreements constituting Permitted Investments under clause (c) of the definition thereof;

(aa) Liens in respect of non-recourse sales or factoring of receivables owned by any Foreign Subsidiary that extend only to the receivables and associated ancillary rights subject thereto;

(bb) Liens securing insurance premiums financing arrangements; provided, that such Liens are limited to the applicable unearned insurance premiums;

(cc) in the case of Real Property that constitutes a leasehold interest, any Lien to which the fee simple interest (or any superior leasehold interest) is subject;

(dd) Liens securing Indebtedness or other obligation (i) of the Borrower or a Subsidiary in favor of the Borrower or any Subsidiary Loan Party and (ii) of any Subsidiary that is not Loan Party in favor of any Subsidiary that is not a Loan Party;

(ee) Liens on not more than \$2,000,000 of deposits securing Hedging Agreements entered into for non-speculative purposes;

(ff) Liens on goods or inventory the purchase, shipment or storage price of which is financed by a documentary letter of credit, bank guarantee or bankers' acceptance issued or created for the account of the Borrower or any Subsidiary in the ordinary course of business; provided, that such Lien secures only the obligations of the Borrower or such Subsidiaries in respect of such letter of credit, bank guarantee or banker's acceptance to the extent permitted under Section 6.01;

(gg) Liens on the Collateral that are junior to the Liens thereon securing the Loan Obligations securing Indebtedness incurred under Section 6.01(r) so long as such junior Liens are subject to a Permitted Intercreditor Agreement;

(hh) Liens imposed by applicable law on the assets of the Borrower or any Subsidiary located at an airport for the benefit of any nation or government or national or governmental authority of any nation, state, province or other political subdivision thereof, and any agency, department, regulator, airport authority, air navigation authority or other entity exercising executive, legislative, judicial, regulatory or administrative functions of or pertaining to government in respect of the regulation of commercial aviation or the registration, airworthiness or operation of civil aircraft and having jurisdiction over the Borrower or such Subsidiary including, without limitation, the FAA or DOT;

(ii) Liens on any aircraft and aircraft equipment, including airframes, engines, appliances, equipment, instruments or related property securing Indebtedness permitted by Section 6.01(p);

(jj) [Reserved];

(kk) Liens to secure any Indebtedness issued or incurred to Refinance (or successive Indebtedness issued or incurred for subsequent Refinancings) as a whole, or in part, any Indebtedness secured by any Lien permitted by this Section 6.02; provided, however, that (x) such new Lien shall be limited to all or part of the same type of property that secured the original Lien (plus improvements on and accessions to such property, proceeds and products thereof, customary security deposits and any other assets pursuant to after-acquired property clauses to the extent such assets secured (or would have secured) the Indebtedness being Refinanced), (y) the Indebtedness secured by such Lien at such time is not increased to any



amount greater than the sum of (A) the outstanding principal amount (or accreted value, if applicable) or, if greater, committed amount of the applicable Indebtedness at the time the original Lien became a Lien permitted hereunder, (B) unpaid accrued interest and premium (including tender premiums) and (C) an amount necessary to pay any associated underwriting discounts, defeasance costs, fees, commissions and expenses, and (z) on the date of the incurrence of the Indebtedness secured by such Liens, the grantors of any such Liens shall be no different from the grantors of the Liens securing the Indebtedness being Refinanced or grantors that would have been obligated to secure such Indebtedness or a Loan Party;

(ll) Liens encumbering reasonable customary initial deposits and margin deposits and similar Liens attaching to commodity trading accounts or other commodity brokerage accounts incurred in the ordinary course of business;

(mm) [Reserved]; and

(nn) other Liens with respect to property or assets of the Borrower or any Subsidiary securing obligations in an aggregate principal amount that at the time of, and after giving effect to, the incurrence of such Liens, would not exceed the greater of \$5,000,000 and 0.046 times EBITDAR calculated on a Pro Forma Basis for the then most recently ended Test Period.

For purposes of determining compliance with this Section 6.02, (A) a Lien securing an item of Indebtedness need not be permitted solely by reference to one category of permitted Liens described in Sections 6.02(a) through (nn) but may be permitted in part under any combination thereof and (B) in the event that a Lien securing an item of Indebtedness (or any portion thereof) meets the criteria of one or more of the categories of permitted Liens described in Sections 6.02(a) through (nn), the Borrower shall, in its sole discretion, classify or reclassify, or later divide, classify or reclassify, such Lien securing such item of Indebtedness (or any portion thereof) in any manner that complies with this covenant and will only be required to include the amount and type of such Lien or such item of Indebtedness secured by such Lien in one of the above clauses and such Lien securing such item of Indebtedness will be treated as being incurred or existing pursuant to only one of such clauses. In addition, with respect to any Lien securing Indebtedness that was permitted to secure such Indebtedness at the time of the incurrence of such Indebtedness, such Lien shall also be permitted to secure any Increased Amount of such Indebtedness.

With respect to each of clauses (c), (i) and (t)(ii) of this Section 6.02, it is hereby understood that with respect to any Liens on the Collateral being incurred under such clause to secure Permitted Refinancing Indebtedness, if Liens on the Collateral securing the Indebtedness being Refinanced (if any) were secured on a basis junior to the Liens thereon securing the Loan Obligations, then any Liens on such Collateral being incurred under such clause to secure Permitted Refinancing Indebtedness shall also be secured on a basis junior to the Liens thereon securing the Loan Obligations, and any such Liens shall be subject to a Permitted Intercreditor Agreement, as applicable.

Section 6.03 Sale and Lease-Back Transactions. Enter into any arrangement, directly or indirectly, with any person whereby it shall sell or transfer any property, real or personal, used or useful in its business, whether now owned or hereafter acquired, and thereafter, as part of such transaction, rent or lease such property or other property that it intends to use for substantially the same purpose or purposes as the property being sold or transferred (a "Sale and Lease-Back Transaction"); provided, that a Sale and Lease-Back Transaction shall be permitted with respect to (i) Excluded Property, (ii) property owned by any Subsidiary that is not a Loan Party regardless of when such property was acquired and (iii) real property owned by the Borrower or any Subsidiary Loan Party; provided, that (A) the aggregate fair market value (as determined by the Borrower in good faith) of all Disposed of property pursuant to this clause (iii) shall not exceed \$5,000,000 and (B) the Borrower or the applicable Subsidiary Loan Party shall receive cash and cash equivalents of at least fair market value (as determined by the Borrower in good faith) for any such Disposed of property pursuant to this clause (iii), and (iv) aircrafts and related assets, including transactions through equipment trust certificates or enhanced equipment trust certificates structures.

Section 6.04 Investments, Loans and Advances. (i) Purchase or acquire (including pursuant to any merger with a person that is not a Wholly Owned Subsidiary immediately prior to such merger) any Equity Interests, evidences of Indebtedness or other securities of any other person, (ii) make any loans or advances to or Guarantees of the Indebtedness of any other person (other than loans or advances in respect of (A) intercompany current liabilities incurred in connection with the cash management operations of the Borrower and the Subsidiaries and (B) intercompany loans, advances or Indebtedness having a term not exceeding 364 days (inclusive of any roll-overs or extensions of terms) and made in the ordinary course of business or consistent with industry practices), or (iii) purchase or otherwise acquire, in one transaction or a series of related transactions, (x) all or substantially all of the property and assets or business of another person or (y) assets constituting a business unit, line of business or division of such person (each of the foregoing, an "Investment"), except:

(a) Investments made pursuant to the Purchase Agreement or in connection with the Transactions;

(b) after giving effect to the applicable Investments, (i) Investments by the Borrower or any Subsidiary in the Equity Interests of the Borrower or any Subsidiary; (ii) intercompany loans from the Borrower or any Subsidiary to the Borrower or any Subsidiary; and (iii) Guarantees by the Borrower or any Subsidiary of Indebtedness otherwise permitted hereunder of the Borrower or any Subsidiary; provided, that as at any date of determination, the aggregate amount of (A) Investments (valued at the time of the making thereof and without giving effect to any write-downs or write-offs thereof) made after the Closing Date by the Loan Parties pursuant to subclause (i) in Subsidiaries that are not Subsidiary Loan Parties, plus (B) net outstanding intercompany loans made after the Closing Date by the Loan Parties to Subsidiaries that are not Subsidiary Loan Parties pursuant to subclause (ii), plus (C) outstanding Guarantees by the Loan Parties of Indebtedness after the Closing Date of Subsidiaries that are not Subsidiary Loan Parties pursuant to subclause (iii) shall not exceed the sum of (X) the greater of (1) \$5,000,000 and (2) 0.046 times EBITDAR calculated on a Pro Forma Basis for the then most recently ended Test Period plus (Y) an amount equal to any returns (including dividends, interest, distributions, returns of principal, profits on sale, repayments, income and similar amounts) actually received in respect of any such Investment;

(c) Permitted Investments and Investments that were Permitted Investments when made;

(d) Investments arising out of the receipt by the Borrower or any Subsidiary of non-cash consideration for the sale of assets permitted under Section 6.05;

(e) loans and advances to officers, directors, employees or consultants of the Borrower or any Subsidiary (i) in the ordinary course of business not to exceed the greater of \$1,000,000 and 0.009 times EBITDAR calculated on a Pro Forma Basis for the then most recently ended Test Period in the aggregate at any time outstanding (calculated without regard to write downs or write offs thereof), (ii) in respect of payroll payments and expenses in the ordinary course of business and (iii) in connection with such person's purchase of Equity Interests of Holdings or any Parent Entity solely to the extent that the amount of such loans and advances shall be contributed to the Borrower in cash as common equity;

(f) accounts receivable, security deposits and prepayments arising and trade credit granted in the ordinary course of business and any assets or securities received in satisfaction or partial satisfaction thereof from financially troubled account debtors to the extent reasonably necessary in order to prevent or limit loss and any prepayments and other credits to suppliers made in the ordinary course of business;

(g) Hedging Agreements entered into for non-speculative purposes;

(h) Investments existing on, or contractually committed as of, the Closing Date and set forth on Schedule 6.04 and any extensions, renewals or reinvestments thereof, so long as the aggregate amount of all Investments pursuant to this clause (h) is not increased at any time above the amount of such Investment existing or committed on the Closing Date (other than pursuant to an increase as required by the terms of any such Investment as in existence on the Closing Date);

(i) Investments resulting from pledges and deposits under Sections 6.02(f), (g), (o), (r), (s), (ee), (ll) and (nn);

(j) other Investments by the Borrower or any Subsidiary in an aggregate amount (valued at the time of the making thereof, and without giving effect to any write-downs or write-offs thereof) not to exceed the sum of (X) the greater of \$5,000,000 and 0.046 times EBITDAR calculated on a Pro Forma Basis for the then most recently ended Test Period, plus (Y) an amount equal to any returns (including dividends, interest, distributions, returns of principal, profits on sale, repayments, income and similar amounts) actually received in respect of any such Investment pursuant to clause (X); provided, that if any Investment pursuant to this Section 6.04(j) is made in any person that was not a Subsidiary on the date on which such Investment was made but becomes a Subsidiary thereafter, then such Investment may, at the option of the Borrower, upon such person becoming a Subsidiary and so long as such person remains a Subsidiary, be deemed to have been made pursuant to Section 6.04(b) (to the extent permitted by the proviso thereto in the case of any Subsidiary that is not a Loan Party) and not in reliance on this Section 6.04(j);

(k) Investments constituting Permitted Business Acquisitions;

(l) intercompany loans between Subsidiaries that are not Loan Parties and Guarantees by Subsidiaries that are not Loan Parties permitted by Section 6.01(m);

(m) Investments received in connection with the bankruptcy or reorganization of, or settlement of delinquent accounts and disputes with or judgments against, customers and suppliers, in each case in the ordinary course of business or Investments acquired by the Borrower or a Subsidiary as a result of a foreclosure by the Borrower or any of the Subsidiaries with respect to any secured Investments or other transfer of title with respect to any secured Investment in default;

(n) Investments of a Subsidiary acquired after the Closing Date or of a person merged into the Borrower or merged into or consolidated with a Subsidiary after the Closing Date, in each case, (i) to the extent such acquisition, merger or consolidation is permitted under this Section 6.04, (ii) in the case of any acquisition, merger or consolidation, in accordance with Section 6.05 and (iii) to the extent that such Investments were not made in contemplation of or in connection with such acquisition, merger or consolidation and were in existence on the date of such acquisition, merger or consolidation;

(o) acquisitions by the Borrower of obligations of one or more officers or other employees of Holdings, any Parent Entity, the Borrower or the Subsidiaries in connection with such officer's or employee's acquisition of Equity Interests of Holdings or any Parent Entity, so long as no cash is actually advanced by the Borrower or any of the Subsidiaries to such officers or employees in connection with the acquisition of any such obligations;

(p) Guarantees by the Borrower or any Subsidiary of operating leases (other than Capitalized Lease Obligations) or of other obligations that do not constitute Indebtedness, in each case entered into by the Borrower or any Subsidiary in the ordinary course of business;

(q) Investments to the extent that payment for such Investments is made with Equity Interests of Holdings or any Parent Entity;

(r) Investments in the Equity Interests of one or more newly-formed persons that are received in consideration of the contribution by Holdings, the Borrower or the applicable Subsidiary of assets (including Equity Interests and cash) to such person or persons; provided, that (i) the fair market value of such assets, determined in good faith by the Borrower, so contributed pursuant to this clause (r) shall not in the aggregate exceed \$5,000,000 and (ii) in respect of each such contribution, a Responsible Officer of the Borrower shall certify, in a form to be agreed upon by the Borrower and the Administrative Agent (x) after giving effect to such contribution, no Default or Event of Default shall have occurred and be continuing or would result therefrom, (y) the fair market value (as determined in good faith by the Borrower) of the assets so contributed and (z) that the requirements of clause (i) of this proviso remain satisfied;

(s) Investments consisting of Restricted Payments permitted under Section 6.06;

- (t) Investments in the ordinary course of business consisting of Uniform Commercial Code Article 3 endorsements for collection or deposit and Uniform Commercial Code Article 4 customary trade arrangements with customers;
- (u) Investments in Subsidiaries that are not Loan Parties after giving effect to the applicable Investments in an aggregate amount (valued at the time of the making thereof and without giving effect to any write-downs or write-offs thereof) not to exceed the sum of the greater of \$5,000,000 and 0.046 times EBITDAR calculated on a Pro Forma Basis for the then most recently ended Test Period in the aggregate plus (y) an amount equal to any returns (including dividends, interest, distributions, returns of principal, profits on sale, repayments, income and similar amounts) actually received in respect of Investments theretofore made pursuant to this Section 6.04(u);
- (v) Guarantees permitted under Section 6.01 (except to the extent such Guarantee is expressly subject to this Section 6.04);
- (w) advances in the form of a prepayment of expenses, so long as such expenses are being paid in accordance with customary trade terms of the Borrower or such Subsidiary;
- (x) Investments by the Borrower and the Subsidiaries, including loans to any direct or indirect parent of the Borrower, if the Borrower or any other Subsidiary would otherwise be permitted to make a Restricted Payment in such amount (provided, that the amount of any such Investment shall also be deemed to be a Restricted Payment under the appropriate clause of Section 6.06 for all purposes of this Agreement);
- (y) Investments consisting of the licensing or contribution of Intellectual Property pursuant to joint marketing arrangements with other persons;
- (z) to the extent constituting Investments, purchases and acquisitions of inventory, supplies, materials and equipment or purchases of contract rights or licenses or leases of Intellectual Property in each case in the ordinary course of business;
- (aa) Investments received substantially contemporaneously in exchange for Equity Interests of the Borrower, Holdings or any Parent Entity;
- (bb) Investments in joint ventures in an aggregate amount not to exceed the sum of (X) the greater of \$5,000,000 and 0.046 times EBITDAR calculated on a Pro Forma Basis for the then most recently ended Test Period, plus (Y) an aggregate amount equal to any returns (including dividends, interest, distributions, returns of principal, profits on sale, repayments, income and similar amounts) actually received by the respective investor in respect of investments theretofore made by it pursuant to this clause (bb); provided, that if any Investment pursuant to this clause (bb) is made in any person that was not a Subsidiary on the date on which such Investment was made but becomes a Subsidiary thereafter, then such Investment may, at the option of the Borrower, upon such person becoming a Subsidiary and so long as such person remains a Subsidiary, be deemed to have been made pursuant to Section 6.04(b) (to the extent permitted by the proviso thereto in the case of any Subsidiary that is not a Loan Party) and not in reliance on this Section 6.04(bb);

(cc) Investments in a Similar Business in an aggregate amount (valued at the time of the making thereof, and without giving effect to any write downs or write offs thereof) not to exceed the sum of (X) the greater of \$5,000,000 and 0.046 times EBITDAR calculated on a Pro Forma Basis for the then most recently ended Test Period plus (Y) an amount equal to any returns (including dividends, interest, distributions, returns of principal, profits on sale, repayments, income and similar amounts) actually received in respect of any such Investment; provided, that if any Investment pursuant to this clause (cc) is made in any person that was not a Subsidiary on the date on which such Investment was made but becomes a Subsidiary thereafter, then such Investment may, at the option of the Borrower, upon such person becoming a Subsidiary and so long as such person remains a Subsidiary, be deemed to have been made pursuant to Section 6.04(b) (to the extent permitted by the proviso thereto in the case of any Subsidiary that is not a Loan Party) and not in reliance on this Section 6.04(cc);

(dd) Investments in any Unrestricted Subsidiaries in an aggregate amount (valued at the time of the making thereof, and without giving effect to any write downs or write offs thereof) not to exceed the sum of (X) the greater of \$2,000,000 and 0.018 times EBITDAR calculated on a Pro Forma Basis for the then most recently ended Test Period plus (Y) an amount equal to any returns (including dividends, interest, distributions, returns of principal, profits on sale, repayments, income and similar amounts) actually received in respect of any such Investment; provided, that if any Investment pursuant to this Section 6.04(dd) is made in any person that was not a Subsidiary on the date on which such Investment was made but becomes a Subsidiary thereafter, then such Investment may, at the option of the Borrower, upon such person becoming a Subsidiary and so long as such person remains a Subsidiary, be deemed to have been made pursuant to Section 6.04(b) (to the extent permitted by the proviso thereto in the case of any Subsidiary that is not a Loan Party) and not in reliance on this Section 6.04(dd); and

(ee) other Investments; provided, that at the time such Investment is made, the Payment Conditions are satisfied;

The amount of Investments that may be made at any time pursuant to Section 6.04(b), 6.04(j) or 6.04(cc) (such Sections, the “Related Sections”) may, at the election of the Borrower, be increased by the amount of Investments that could be made at such time under the other Related Sections; provided, that the amount of each such increase in respect of one Related Section shall be treated as having been used under one of the other Related Sections.

Any Investment in any person other than the Borrower or a Subsidiary Loan Party that is otherwise permitted by this Section 6.04 may be made through intermediate Investments in Subsidiaries that are not Loan Parties and such intermediate Investments shall be disregarded for purposes of determining the outstanding amount of Investments pursuant to any clause set forth above. The amount of any Investment made other than in the form of cash or cash equivalents shall be the fair market value thereof (as determined by the Borrower in good faith) valued at the time of the making thereof, and without giving effect to any write-downs or write- offs thereof.

Section 6.05 Mergers, Consolidations, Sales of Assets and Acquisitions. Merge into or consolidate with any other person, or permit any other person to merge into or consolidate with it, or Dispose of (in one transaction or in a series of related transactions) all or any part of its assets (whether now owned or hereafter acquired), or Dispose of any Equity Interests of any Subsidiary, or purchase, lease or otherwise acquire (in one transaction or a series of related transactions) all of the assets of any other person or division or line of business of a person, except that this Section 6.05 shall not prohibit:

(a) (i) the purchase and Disposition of inventory, or the non-recourse sale or factoring of receivables that are owned by any Foreign Subsidiary, in each case, in the ordinary course of business by the Borrower or any Subsidiary, (ii) the acquisition or lease (pursuant to an operating lease) of any other asset in the ordinary course of business by the Borrower or any Subsidiary or, with respect to operating leases, otherwise for fair market value on market terms (as determined in good faith by the Borrower), (iii) the Disposition of surplus, obsolete, damaged or worn out equipment or other property in the ordinary course of business by the Borrower or any Subsidiary, (iv) the assignment by the Borrower and any Subsidiary in connection with insurance arrangements of their rights and remedies under, and with respect to, the Purchase Agreement in respect of any breach by any Seller of its representations and warranties set forth therein or (v) the Disposition of Permitted Investments in the ordinary course of business;

(b) if at the time thereof and immediately after giving effect thereto no Event of Default shall have occurred and be continuing or would result therefrom, (i) the merger or consolidation of any Subsidiary with or into the Borrower in a transaction in which the Borrower is the survivor, (ii) the merger or consolidation of any Subsidiary with or into any Subsidiary Loan Party in a transaction in which the surviving or resulting entity is or becomes a Subsidiary Loan Party and, in the case of each of clauses (i) and (ii), no person other than the Borrower or a Subsidiary Loan Party receives any consideration, (iii) the merger or consolidation of any Subsidiary that is not a Subsidiary Loan Party with or into any other Subsidiary that is not a Subsidiary Loan Party, (iv) the liquidation or dissolution or change in form of entity of any Subsidiary if the Borrower determines in good faith that such liquidation, dissolution or change in form is in the best interests of the Borrower and is not materially disadvantageous to the Lenders or (v) any Subsidiary may merge or consolidate with any other person in order to effect an Investment permitted pursuant to Section 6.04 so long as the continuing or surviving person shall be a Subsidiary, which shall be a Loan Party if the merging or consolidating Subsidiary was a Loan Party and which together with each of the Subsidiaries shall have complied with the requirements of Section 5.10;

(c) Dispositions to the Borrower or a Subsidiary (upon voluntary liquidation or otherwise); provided, that any Dispositions by a Loan Party to a Subsidiary that is not a Subsidiary Loan Party in reliance on this clause (c) shall be made either (i) on terms that are substantially no less favorable to such Loan Party, as applicable, than would be obtained in a comparable arm's-length transaction with a person that is not an Affiliate, as determined by the Board of Directors of such Loan Party in good faith or (ii) be counted as an Investment to the extent of any shortfall below fair market value and permitted to the extent permitted by Section 6.07;

- (d) Sale and Lease-Back Transactions permitted by Section 6.03;
- (e) (i) Investments permitted by Section 6.04, Permitted Liens, and Restricted Payments permitted by Section 6.06 and (ii) any Disposition made pursuant to the Purchase Agreement;
- (f) Dispositions of defaulted receivables in the ordinary course of business and not as part of an accounts receivable financing transaction;
- (g) Dispositions of assets not otherwise permitted by this Section 6.05;
- (h) Permitted Business Acquisitions (including any merger, consolidation or amalgamation in order to effect a Permitted Business Acquisition); provided, that following any such merger, consolidation or amalgamation involving the Borrower, the Borrower is the surviving entity;
- (i) leases, licenses or subleases or sublicenses any real or personal property in the ordinary course of business;
- (j) Dispositions of inventory of Dispositions or abandonment of Intellectual Property of the Borrower and the Subsidiaries determined in good faith by the management of the Borrower to be no longer useful or necessary in the operation of the business of the Borrower or any of the Subsidiaries (including any Disposition of foreign Intellectual Property rights);
- (k) [Reserved];
- (l) any exchange of assets for services and/or other assets of comparable or greater value; provided, that (i) at least 90% of the consideration received by the transferor consists of assets that will be used in a business or business activity permitted hereunder, (ii) in the event of a swap with a fair market value (as determined in good faith by the Borrower) in excess of \$500,000, the Administrative Agent shall have received a certificate from a Responsible Officer of the Borrower with respect to such fair market value and (iii) in the event of a swap with a fair market value (as determined in good faith by the Borrower) in excess of \$5,000,000, such exchange shall have been approved by at least a majority of the Board of Directors of Holdings or the Borrower, as applicable; provided, further, that (A) the aggregate gross consideration (including exchange assets, other non-cash consideration and cash proceeds) of any or all assets exchanged in reliance upon this clause (l) shall not exceed, in any fiscal year of the Borrower, the greater of \$5,000,000 and 0.046 times EBITDAR calculated on a Pro Forma Basis for the then most recently ended Test Period and (B)) no Default or Event of Default exists or would result therefrom;
- (m) [Reserved];



(n) Dispositions not otherwise permitted by this Section 6.05; provided, that (i) the aggregate gross proceeds thereof shall not exceed, in any fiscal year of the Borrower, the greater of \$5,000,000 and 0.046 times EBITDAR calculated on a Pro Forma Basis for the then most recently ended Test Period, as applicable (it being understood that amounts not fully utilized in any fiscal year may be carried forward and utilized in subsequent fiscal years); (ii) with respect to any Disposition (in a single transaction or a series of related transactions) of assets constituting Collateral for an aggregate consideration in excess of \$500,000, the Borrower shall have delivered a Borrowing Base Certificate to the Administrative Agent in respect of such Disposition; (iii) no Default or Event of Default exists or would result therefrom and (iv) with respect to any Disposition with aggregate gross proceeds (including noncash proceeds) in excess of \$5,000,000, the Borrower shall be in compliance with the Financial Performance Covenant on a Pro Forma Basis; and

(o) other Dispositions; provided, that at the time such Disposition is made, the Payment Conditions are satisfied; provided, further, that with respect to any Disposition (in a single transaction or a series of related transactions) of assets constituting Collateral for an aggregate consideration in excess of \$500,000, the Borrower shall have delivered a Borrowing Base Certificate to the Administrative Agent in respect of such Disposition.

Notwithstanding anything to the contrary contained in Section 6.05 above, (i) no Disposition of assets under Sections 6.05(d), (g), (n) and (o) shall be permitted unless such Disposition is for fair market value (as determined in good faith by the Borrower), or if not for fair market value, the shortfall is permitted as an Investment under Section 6.04, and (ii) no Disposition of assets under Sections 6.05(g), (n) and (o) shall be permitted unless such Disposition (except to Loan Parties) is for at least 75% cash consideration; provided, that the provisions of this clause (ii) shall not apply to any individual transaction or series of related transactions involving assets with a fair market value (as determined in good faith by the Borrower) of less than \$2,000,000 or to other transactions involving assets with a fair market value of not more than the greater of \$5,000,000 and 0.046 times EBITDAR calculated on a Pro Forma Basis for the then most recently ended Test Period in the aggregate for all such transactions during the term of this Agreement; provided, further, that for purposes of this clause (ii), with respect to Dispositions of assets each of the following shall be deemed to be cash: (a) the amount of any liabilities (as shown on the Borrower's or such Subsidiary's most recent balance sheet or in the notes thereto) that are assumed by the transferee of any such assets or are otherwise cancelled in connection with such transaction, (b) any notes or other obligations or other securities or assets received by the Borrower or such Subsidiary from the transferee that are converted by the Borrower or such Subsidiary into cash within 180 days after receipt thereof (to the extent of the cash received), and (c) any Designated Non-Cash Consideration received by the Borrower or any of the Subsidiaries in such Disposition having an aggregate fair market value (as determined in good faith by the Borrower), taken together with all other Designated Non-Cash Consideration received pursuant to this clause (c) that is at that time outstanding, not to exceed the greater of \$1,000,000 and 0.09 times EBITDAR calculated on a Pro Forma Basis for the then most recently ended Test Period immediately prior to the receipt of such Designated Non-Cash Consideration (with the fair market value of each item of Designated Non-Cash Consideration being measured at the time received and without giving effect to subsequent changes in value).

Section 6.06 Dividends and Distributions. Declare or pay any dividend or make any other distribution (by reduction of capital or otherwise), whether in cash, property, securities or a combination thereof, with respect to any of its Equity Interests (other than dividends and distributions on Equity Interests payable solely by the issuance of additional Equity Interests (other than Disqualified Stock) of the person paying such dividends or distributions) or directly or indirectly redeem, purchase, retire or otherwise acquire for value (or permit any Subsidiary to purchase or acquire) any of the Borrower's Equity Interests or set aside any amount for any such purpose (other than through the issuance of additional Equity Interests (other than Disqualified Stock) of the person redeeming, purchasing, retiring or acquiring such shares) (all of the foregoing, "Restricted Payments"); provided, however, that:

(a) Restricted Payments may be made to the Borrower or any Wholly Owned Subsidiary of the Borrower (or, in the case of non-Wholly Owned Subsidiaries, to the Borrower or any Subsidiary that is a direct or indirect parent of such Subsidiary and to each other owner of Equity Interests of such Subsidiary on a pro rata basis (or more favorable basis from the perspective of the Borrower or such Subsidiary) based on their relative ownership interests);

(b) Restricted Payments may be made in respect of (i) overhead, legal, accounting and other professional fees and expenses of Holdings or any Parent Entity, (ii) fees and expenses related to any public offering or private placement of Equity Interests or debt securities of Holdings or any Parent Entity whether or not consummated, (iii) franchise and similar taxes and other fees and expenses in connection with the maintenance of its (and any Parent Entity's) existence and its (or any Parent Entity's indirect) ownership of the Borrower, (iv) payments permitted by Section 6.07(b) (other than Section 6.07(b)(vii)), (v) (A) in respect of any taxable period for which the Borrower and/or any of its Subsidiaries are members of a consolidated, combined, affiliated, unitary or similar tax group for U.S. federal and/or applicable state, local or foreign tax purposes of which a direct or indirect parent of the Borrower is the common parent, or for which the Borrower is a disregarded entity for U.S. federal income tax purposes that is wholly owned (directly or indirectly) by a C corporation for U.S. federal and/or applicable state or local income tax purposes, distributions to any direct or indirect parent of the Borrower in an amount not to exceed the amount of any U.S. federal, state, local or foreign taxes that the Borrower and/or its Subsidiaries, as applicable, would have paid for such taxable period had the Borrower and/or its Subsidiaries, as applicable, been a stand-alone corporate taxpayer or a stand-alone corporate group or (B) in respect of any taxable period for which the Borrower is treated as a partnership or disregarded entity for U.S. federal and/or applicable state, local or foreign tax purposes, except in the case in which the Borrower is treated as a disregarded entity for U.S. federal income tax purposes that is wholly owned (directly or indirectly) by a C Corporation for U.S. federal and/or applicable state or local income tax purposes, distributions to any direct or indirect owners of the Borrower in an amount not to exceed the product of the amount of taxable income of the Borrower and/or the Subsidiaries for such taxable period, and the Hypothetical Tax Rate and (vi) customary salary, bonus and other benefits payable to, and indemnities provided on behalf of, officers, directors and employees of Holdings or any Parent Entity, in each case in order to permit Holdings or any Parent Entity to make such payments; provided, that in the case of subclauses (i) and (iii), the amount of such Restricted Payments shall not exceed the portion of any amounts referred to in such subclauses (i) and (iii) that are allocable to the Borrower and its Subsidiaries (which shall be 100% at any time that, as the case may be, (x) Holdings owns no material assets other than the Equity Interests in the Borrower and assets incidental to such equity ownership or (y) any Parent Entity owns directly or indirectly no material assets other than Equity Interests in Holdings and any other Parent Entity and assets incidental to such equity ownership);

(c) Restricted Payments may be made to Holdings, the proceeds of which are used to purchase or redeem the Equity Interests of Holdings, the Borrower or any Parent Entity or Subsidiaries (including related stock appreciation rights or similar securities) held by then present or former directors, consultants, officers or employees of any Parent Entity, Holdings, the Borrower or any of the Subsidiaries or by any Plan or any shareholders' agreement then in effect upon such person's death, disability, retirement or termination of employment or under the terms of any such Plan or any other agreement under which such shares of stock or related rights were issued; provided, that the aggregate amount of such purchases or redemptions under this clause (c) shall not exceed in any calendar year \$1,000,000 (which shall increase to \$2,000,000 subsequent to a Qualified IPO) (plus (x) the amount of net proceeds contributed to the Borrower that were (x) received by Holdings or any Parent Entity during such calendar year from sales of Equity Interests of Holdings or any Parent Entity to directors, consultants, officers or employees of Holdings, any Parent Entity, the Borrower or any Subsidiary in connection with permitted employee compensation and incentive arrangements, (y) the amount of net proceeds of any key-man life insurance policies received during such calendar year, and (z) the amount of any cash bonuses otherwise payable to members of management, directors or consultants of Holdings, any Parent Entity, the Borrower or the Subsidiaries in connection with the Transactions that are foregone in return for the receipt of Equity Interests), which, if not used in any year, may be carried forward to any subsequent calendar year; and provided, further, that cancellation of Indebtedness owing to the Borrower or any Subsidiary from members of management of Holdings, any Parent Entity, the Borrower or its Subsidiaries in connection with a repurchase of Equity Interests of Holdings or any Parent Entity will not be deemed to constitute a Restricted Payment for purposes of this Section 6.06;

(d) any person may make non-cash repurchases of Equity Interests deemed to occur upon exercise of stock options if such Equity Interests represent a portion of the exercise price of such options;

(e) any Restricted Payments may be made so long as the Payment Conditions are satisfied at the time such Restricted Payments are made;

(f) Restricted Payments may be made under the Purchase Agreement (as in effect on the Closing Date);

(g) Restricted Payments may be made to pay, or to allow Holdings or any Parent Entity to make payments, in cash, in lieu of the issuance of fractional shares, upon the exercise of warrants or upon the conversion or exchange of Equity Interests of any such person;

(h) after a Qualified IPO, Restricted Payments may be made to pay, or to allow Holdings or any Parent Entity to pay, dividends and make distributions to, or repurchase or redeem shares from, its equity holders in an amount per annum no greater than 6.0% of the net proceeds received by Holdings, the Borrower or any Parent Entity from any public offering of Equity Interests of the Borrower or any Parent Entity;

(i) Restricted Payments may be made to Holdings or any Parent Entity to finance any Investment that if made by the Borrower or any Subsidiary directly would be permitted to be made pursuant to Section 6.04; provided, that (A) such Restricted Payment shall be made substantially concurrently with the closing of such Investment and (B) such parent shall, immediately following the closing thereof, cause (1) all property acquired (whether assets or Equity Interests) to be contributed to the Borrower or a Subsidiary or (2) the merger, consolidation or amalgamation (to the extent permitted in Section 6.05) of the person formed or acquired into the Borrower or a Subsidiary in order to consummate such Permitted Business Acquisition or Investment, in each case, in accordance with the requirements of Section 5.10;

(j) [Reserved];

(k) other Restricted Payments may be made in an aggregate amount not to exceed \$5,000,000; or

(l) Restricted Payments may be made in connection with the Transactions.

Notwithstanding anything herein to the contrary, the foregoing provisions of Section 6.06 will not prohibit the payment of any Restricted Payment or the consummation of any redemption, purchase, defeasance or other payment within 60 days after the date of declaration thereof or the giving of notice, as applicable, if at the date of declaration or the giving of such notice such payment would have complied with the provisions of this Agreement.

Section 6.07 Transactions with Affiliates. (a) Sell or transfer any property or assets to, or purchase or acquire any property or assets from, or otherwise engage in any other transaction with, any of its Affiliates (other than the Borrower, Holdings, and the Subsidiaries or any person that becomes a Subsidiary as a result of such transaction) in a transaction (or series of related transactions) involving aggregate consideration in excess of \$5,000,000, unless such transaction (or series of related transactions) is (i) otherwise permitted (or required) under this Agreement or (ii) upon terms that are substantially no less favorable to the Borrower or such Subsidiary, as applicable, than would be obtained in a comparable arm's-length transaction with a person that is not an Affiliate, as determined by the Board of Directors of the Borrower or such Subsidiary in good faith.

(b) The foregoing clause (a) shall not prohibit, to the extent otherwise permitted under this Agreement,

(i) any issuance of securities, or other payments, awards or grants in cash, securities or otherwise pursuant to, or the funding of, employment arrangements, equity purchase agreements, stock options and stock ownership plans approved by the Board of Directors of Holdings or of the Borrower,

(ii) loans or advances to employees or consultants of Holdings (or any Parent Entity), the Borrower or any of the Subsidiaries in accordance with Section 6.04(e),

(iii) transactions among the Borrower or any Subsidiary or any entity that becomes a Subsidiary as a result of such transaction (including via merger, consolidation or amalgamation in which a Subsidiary is the surviving entity),

(iv) the payment of fees, reasonable out-of-pocket costs and indemnities to directors, officers, consultants and employees of Holdings, any Parent Entity, the Borrower and the Subsidiaries in the ordinary course of business (limited, in the case of any Parent Entity, to the portion of such fees and expenses that are allocable to the Borrower and its Subsidiaries (which (x) shall be 100% for so long as Holdings or such Parent Entity, as the case may be, owns no assets other than the Equity Interests in the Borrower, Holdings or any Parent Entity and assets incidental to the ownership of the Borrower and its Subsidiaries and (y) in all other cases shall be as determined in good faith by management of the Borrower)),

(v) subject to the limitations set forth in Section 6.07(b)(xiv), if applicable, the Transactions and any transactions pursuant to the Transaction Documents and permitted transactions, agreements and arrangements in existence on the Closing Date and, to the extent involving aggregate consideration in excess of \$5,000,000, set forth on Schedule 6.07 or any amendment thereto or replacement thereof or similar arrangement to the extent such amendment, replacement or arrangement is not adverse to the Lenders when taken as a whole in any material respect (as determined by the Borrower in good faith),

(vi) (A) any employment agreements entered into by the Borrower or any of the Subsidiaries in the ordinary course of business, (B) any subscription agreement or similar agreement pertaining to the repurchase of Equity Interests pursuant to put/call rights or similar rights with employees, officers or directors, and (C) any employee compensation, benefit plan or arrangement, any health, disability or similar insurance plan which covers employees, and any reasonable employment contract and transactions pursuant thereto,

(vii) Restricted Payments permitted under Section 6.06, including payments to Holdings (and any Parent Entity), and Investments permitted under Section 6.04,

(viii) any purchase by Holdings of the Equity Interests of the Borrower; provided, that any Equity Interests of the Borrower purchased by Holdings (prior to a Qualified IPO of the Borrower) shall be pledged to the Collateral Agent (and deliver the relevant certificates or other instruments (if any) representing such Equity Interests to the Collateral Agent) on behalf of the Lenders to the extent required by the Collateral Agreement,

(ix) payments by the Borrower or any of the Subsidiaries to the Fund or any Fund Affiliate made for any financial advisory, financing, underwriting or placement services or in respect of other investment banking activities, including in connection with acquisitions or divestitures, which payments are approved by the majority of the Board of Directors of the Borrower, or a majority of Disinterested Directors of the Borrower, in good faith,

(x) transactions for the purchase or sale of goods, equipment, products, parts and services entered into in the ordinary course of business,

(xi) any transaction in respect of which the Borrower delivers to the Administrative Agent a letter addressed to the Board of Directors of the Borrower from an accounting, appraisal or investment banking firm, in each case of nationally recognized standing that is (A) in the good faith determination of the Borrower qualified to render such letter and (B) reasonably satisfactory to the Administrative Agent, which letter states that (i) such transaction is on terms that are no less favorable to the Borrower or such Subsidiary, as applicable, than would be obtained in a comparable arm's-length transaction with a person that is not an Affiliate or (ii) such transaction is fair to the Borrower or such Subsidiary, as applicable, from a financial point of view,

(xii) subject to subclause (xiv) below, if applicable, the payment of all fees, expenses, bonuses and awards related to the Transactions, including fees to the Fund or any Fund Affiliate,

(xiii) transactions with joint ventures for the purchase or sale of goods, equipment, products, parts and services entered into in the ordinary course of business,

(xiv) any agreement to pay, and the payment of, monitoring, consulting, management, transaction, advisory or similar fees payable to the Fund or any Fund Affiliate (A) in an aggregate amount in any fiscal year not to exceed the sum of (1) the greater of \$2,500,000 and .023 times EBITDAR for any such fiscal year, plus reasonable out of pocket costs and expenses in connection therewith in any fiscal year and unpaid amounts for any prior periods from and including the fiscal year in which the Closing Date occurs; plus (2) any deferred, accrued or other fees in respect of any fiscal years from and including the fiscal year in which the Closing Date occurs (to the extent such fees in the aggregate do not exceed the amounts described in clause (A)(1) above in respect of such fiscal years), plus (B) 2.0% of the value of transactions (including the Transactions) with respect to which the Fund or any Fund Affiliate provides any transaction, advisory or other services, plus (C) so long as no Event of Default has occurred and is continuing, the present value of all future amounts payable pursuant to any agreement referred to in clause (A)(1) above in connection with the termination of such agreement with the Fund and its Fund Affiliates; provided, that if any such payment pursuant to clause (C) is not permitted to be paid as a result of an Event of Default, such payment shall accrue and may be payable when no Events of Default are continuing to the extent that no further Event of Default would result therefrom,

(xv) the issuance, sale or transfer of Equity Interests of the Borrower or any Subsidiary to Holdings (or any Parent Entity) and capital contributions by Holdings (or any Parent Entity) to the Borrower or any Subsidiary,

(xvi) the issuance of Equity Interests to the management of Holdings, any Parent Entity, the Borrower or any Subsidiary in connection with the Transactions,

(xvii) payments by Holdings (and any Parent Entity), the Borrower and the Subsidiaries pursuant to a tax sharing agreement or arrangement (whether written or as a matter of practice) that complies with clause (v) of Section 6.06(b),

(xviii) payments, loans (or cancellation of loans) or advances to employees or consultants that are (i) approved by a majority of the Disinterested Directors of Holdings or the Borrower in good faith, (ii) made in compliance with applicable law and (iii) otherwise permitted under this Agreement,

(xix) transactions with customers, clients, suppliers, or purchasers or sellers of goods or services, in each case in the ordinary course of business and otherwise in compliance with the terms of this Agreement that are fair to the Borrower or the Subsidiaries,

(xx) transactions between the Borrower or any of the Subsidiaries and any person, a director of which is also a director of the Borrower or any direct or indirect parent company of the Borrower; provided, however, that (A) such director abstains from voting as a director of the Borrower or such direct or indirect parent company, as the case may be, on any matter involving such other person and (B) such person is not an Affiliate of the Borrower for any reason other than such director's acting in such capacity,

(xxi) transactions permitted by, and complying with, the provisions of Section 6.05,

(xxii) intercompany transactions undertaken in good faith (as certified by a Responsible Officer of the Borrower) for the purpose of improving the consolidated tax efficiency of the Borrower and the Subsidiaries and not for the purpose of circumventing any covenant set forth herein, and

(xxiii) Investments by the Fund or a Fund Affiliate in securities of the Borrower or any of the Subsidiaries so long as (A) the Investment is being offered generally to other investors on the same or more favorable terms and (B) the Investment constitutes less than 5.0% of the outstanding issue amount of such class of securities.

Notwithstanding the foregoing, any portfolio company that is an Affiliate of the Fund or a Fund Affiliate shall not be considered an Affiliate of the Borrower or its Subsidiaries with respect to any transaction, so long as such transaction is in the ordinary course of business and does not involve the disposition of any material assets not otherwise permitted by Section 6.05.

Section 6.08 Business of the Borrower and the Subsidiaries. Notwithstanding any other provisions hereof, engage at any time to any material respect in any business or business activity substantially different from any business or business activity conducted by any of them on the Closing Date or any Similar Business.

Section 6.09 Limitation on Payments and Modifications of Indebtedness; Modifications of Certificate of Incorporation, By-Laws and Certain Other Agreements; etc. (a) Amend or modify in any manner materially adverse to the Lenders when taken as a whole (as determined in good faith by the Borrower), or grant any waiver or release under or terminate in any manner (if such granting or termination shall be materially adverse to the Lenders when taken as a whole (as determined in good faith by the Borrower)), the articles or certificate of incorporation, by-laws, limited liability company operating agreement, partnership agreement or other organizational documents of the Borrower or any of the Subsidiary Loan Parties.

(b) (i) Make, directly or indirectly, any payment or other distribution (whether in cash, securities or other property) of, or in respect of, principal of or interest on any Junior or Specified Financing, or any payment or other distribution (whether in cash, securities or other property), including any sinking fund or similar deposit, on account of the purchase, redemption, retirement, acquisition, cancellation or termination in respect of any Junior or Specified Financing, except for:

(A) Refinancings with any Indebtedness permitted to be incurred under Section 6.01 (other than a Refinancing utilizing proceeds from Loans hereunder),

(B) payments of regularly-scheduled interest and fees due thereunder, other non-principal payments thereunder, any mandatory prepayments of principal, interest and fees thereunder, scheduled payments thereon necessary to avoid the Junior or Specified Financing from constituting “applicable high yield discount obligations” within the meaning of Section 163(i)(1) of the Code, and, to the extent this Agreement is then in effect, principal on the scheduled maturity date of any Junior or Specified Financing,

(C) payments or distributions in respect of all or any portion of the Junior or Specified Financing, as applicable, with the proceeds contributed to the Borrower by Holdings from the issuance, sale or exchange by Holdings (or any Parent Entity) of Equity Interests that are not Permitted Cure Securities applied pursuant to Section 7.02 or Disqualified Stock made within eighteen months prior thereto,

(D) the conversion of any Junior or Specified Financing to Equity Interests of Holdings or any Parent Entity,

(E) additional payments and distributions so long as the Payment Conditions are satisfied at the time such payments or distributions are made,

(F) other payments and distributions in an aggregate amount not to exceed \$5,000,000; or

(ii) Amend or modify, or permit the amendment or modification of, any provision of any Junior or Specified Financing or any Permitted Refinancing Indebtedness in respect thereof, or any agreement, document or instrument evidencing or relating to any of the foregoing, other than amendments or modifications that (A) are not materially adverse to Lenders when taken as a whole (as determined in good faith by the Borrower) and that do not affect the subordination or payment provisions, if applicable, thereof (if any) in a manner adverse to the Lenders when taken as a whole (as determined in good faith by the Borrower) or (B) otherwise comply with the definition of “Permitted Refinancing Indebtedness”.



(c) Permit any Material Subsidiary to enter into any agreement or instrument that by its terms restricts (i) the payment of dividends or distributions or the making of cash advances to the Borrower or any Subsidiary that is a direct or indirect parent of such Subsidiary or (ii) the granting of Liens by the Borrower or such Material Subsidiary that is a Loan Party pursuant to the Security Documents, in each case other than those arising under any Loan Document, except, in each case, restrictions existing by reason of:

(A) restrictions imposed by applicable law;

(B) contractual encumbrances or restrictions in effect on the Closing Date under Indebtedness existing on the Closing Date and set forth on Schedule 6.01 or any agreements related to any Permitted Refinancing Indebtedness in respect of any such Indebtedness that does not materially expand the scope of any such encumbrance or restriction (as determined in good faith by the Borrower);

(C) any restriction on a Subsidiary imposed pursuant to an agreement entered into for the sale or disposition of the Equity Interests or assets of a Subsidiary pending the closing of such sale or disposition;

(D) customary provisions in joint venture agreements and other similar agreements applicable to joint ventures entered into in the ordinary course of business;

(E) any restrictions imposed by any agreement relating to secured Indebtedness permitted by this Agreement to the extent that such restrictions apply only to the property or assets securing such Indebtedness;

(F) any restrictions imposed by any agreement relating to Indebtedness incurred pursuant to Section 6.01(k), (l), (r), (s) or (ff) or Permitted Refinancing Indebtedness in respect thereof;

(G) customary provisions contained in leases or licenses of Intellectual Property and other similar agreements entered into in the ordinary course of business;

(H) customary provisions restricting subletting or assignment of any lease governing a leasehold interest;

(I) customary provisions restricting assignment of any agreement entered into in the ordinary course of business;

(J) customary restrictions and conditions contained in any agreement relating to the sale, transfer, lease or other disposition of any asset permitted under Section 6.05 pending the consummation of such sale, transfer, lease or other disposition;

(K) customary restrictions and conditions contained in the document relating to any Lien, so long as (1) such Lien is a Permitted Lien and such restrictions or conditions relate only to the specific asset subject to such Lien, and (2) such restrictions and conditions are not created for the purpose of avoiding the restrictions imposed by this Section 6.09;

(L) customary net worth provisions contained in Real Property leases entered into by Subsidiaries, so long as the Borrower has determined in good faith that such net worth provisions would not reasonably be expected to impair the ability of the Borrower and the Subsidiaries to meet their ongoing obligations;

(M) any agreement in effect at the time such subsidiary becomes a Subsidiary, so long as such agreement was not entered into in contemplation of such person becoming a Subsidiary;

(N) restrictions in agreements representing Indebtedness permitted under Section 6.01 of a Subsidiary of the Borrower that is not a Subsidiary Loan Party;

(O) customary restrictions contained in leases, subleases, licenses or Equity Interests or asset sale agreements otherwise permitted hereby as long as such restrictions relate to the Equity Interests and assets subject thereto;

(P) restrictions on cash or other deposits imposed by customers under contracts entered into in the ordinary course of business; or

(Q) any encumbrances or restrictions of the type referred to in Section 6.09(c)(i) and Section 6.09(c)(ii) above imposed by any amendments, modifications, restatements, renewals, increases, supplements, refundings, replacements or refinancings of, or similar arrangements to, the contracts, instruments or obligations referred to in clauses (A) through (P) above; provided, that such amendments, modifications, restatements, renewals, increases, supplements, refundings, replacements, refinancings or similar arrangements are, in the good faith judgment of the Borrower, no more restrictive with respect to such dividend and other payment restrictions than those contained in the dividend or other payment restrictions as contemplated by such provisions prior to such amendment, modification, restatement, renewal, increase, supplement, refunding, replacement, refinancing or similar arrangement.

Section 6.10 Minimum EBITDAR. Permit the EBITDAR for any Test Period (beginning with the Test Period ending on the last day of the first full fiscal quarter ending after the Closing Date), solely to the extent that on the last date of such Test Period the Testing Condition is satisfied, to be less than \$87,700,000.

Section 6.11 Fiscal Year. In the case of the Borrower, permit its fiscal year to end on any date other than December 31 without prior notice to the Administrative Agent.

ARTICLE VIA

*Holding Company Covenants*

Holdings (prior to a Qualified IPO) hereby covenants and agrees with each Lender that, from and after the Closing Date and until the Termination Date, unless the Required Lenders shall otherwise consent in writing, (a) Holdings will not create, incur, assume or permit to exist any Lien other than (i) Liens created under the Loan Documents and (ii) Liens not prohibited by Section 6.02 on any of the Equity Interests issued by the Borrower held by Holdings and (b) Holdings shall do or cause to be done all things necessary to preserve, renew and keep in full force and effect its legal existence; provided, that so long as no Default has occurred and is continuing or would result therefrom, Holdings may merge with any other person (and if it is not the survivor of such merger, the survivor shall assume Holdings' obligations, as applicable, under the Loan Documents).

ARTICLE VII

*Events of Default*

Section 7.01 Events of Default. In case of the happening of any of the following events (each, an "Event of Default"):

(a) any representation or warranty made or deemed made by Holdings, the Borrower or any other Loan Party herein or in any other Loan Document, Borrowing Base Certificate or any certificate or document delivered pursuant hereto or thereto shall prove to have been false or misleading in any material respect when so made or deemed made and such false or misleading representation or warranty (if curable) shall remain false or misleading for a period of 30 days after notice thereof from the Administrative Agent to the Borrower or the Borrower becoming aware of such false or misleading representation or warranty;

(b) default shall be made in the payment of any principal of any Loan when and as the same shall become due and payable, whether at the due date thereof or at a date fixed for prepayment thereof or by acceleration thereof or otherwise;

(c) default shall be made in the payment of any interest on any Loan or the reimbursement with respect to any L/C Disbursement or in the payment of any Fee or any other amount (other than an amount referred to in clause (b) above) due under any Loan Document, when and as the same shall become due and payable, and such default shall continue unremedied for a period of five Business Days;

(d) default shall be made in the due observance or performance by the Borrower of any covenant, condition or agreement contained in Section 2.05(e), 5.01(a), 5.05(a) or 5.08 or in Article VI;

(e) default shall be made in the due observance or performance by Holdings (prior to a Qualified IPO) of Article VIA or by the Borrower or any of the Subsidiary Loan Parties of any covenant, condition or agreement contained in (i) Section 5.04(i), 5.04(j), 5.07(b), 5.07(c), or 5.11 and such default shall continue unremedied for a period of seven (7) days after notice thereof from the Administrative Agent to the Borrower, or (ii) any Loan Document (other than those specified in clauses (b), (c) and (d) above) and such default shall continue unremedied for a period of 30 days (or 60 days if such default results solely from the failure of a Subsidiary that is not a Loan Party to duly observe or perform any such covenant, condition or agreement) after notice thereof from the Administrative Agent to the Borrower;

(f) (i) any event or condition occurs that (A) results in any Material Indebtedness becoming due prior to its scheduled maturity or (B) enables or permits (with all applicable grace periods having expired) the holder or holders of any Material Indebtedness or any trustee or agent on its or their behalf to cause any Material Indebtedness to become due, or to require the prepayment, repurchase, redemption or defeasance thereof, prior to its scheduled maturity; or (ii) the Borrower or any of the Subsidiaries shall fail to pay the principal of any Material Indebtedness at the stated final maturity thereof; provided, that this clause (f) shall not apply to any secured Indebtedness that becomes due as a result of the voluntary sale or transfer of the property or assets securing such Indebtedness if such sale or transfer is permitted hereunder and under the documents providing for such Indebtedness;

(g) there shall have occurred a Change in Control;

(h) an involuntary proceeding shall be commenced or an involuntary petition shall be filed in a court of competent jurisdiction seeking (i) relief in respect of the Borrower or any of the Material Subsidiaries, or of a substantial part of the property or assets of the Borrower or any Material Subsidiary, under Title 11 of the United States Code, as now constituted or hereafter amended, or any other federal, state or foreign bankruptcy, insolvency, receivership or similar law, (ii) the appointment of a receiver, trustee, custodian, sequestrator, conservator or similar official for the Borrower or any of the Material Subsidiaries or for a substantial part of the property or assets of the Borrower or any of the Material Subsidiaries or (iii) the winding-up or liquidation of the Borrower or any Material Subsidiary (except in a transaction permitted hereunder); and such proceeding or petition shall continue undismissed for 60 days or an order or decree approving or ordering any of the foregoing shall be entered;

(i) the Borrower or any Material Subsidiary shall (i) voluntarily commence any proceeding or file any petition seeking relief under Title 11 of the United States Code, as now constituted or hereafter amended, or any other federal, state or foreign bankruptcy, insolvency, receivership or similar law, (ii) consent to the institution of, or fail to contest in a timely and appropriate manner, any proceeding or the filing of any petition described in clause (h) above, (iii) apply for or consent to the appointment of a receiver, trustee, custodian, sequestrator, conservator or similar official for the Borrower or any of the Material Subsidiaries or for a substantial part of the property or assets of the Borrower or any Material Subsidiary, (iv) file an answer admitting the material allegations of a petition filed against it in any such proceeding, (v) make a general assignment for the benefit of creditors or (vi) become unable or admit in writing its inability or fail generally to pay its debts as they become due;

(j) the failure by the Borrower or any Material Subsidiary to pay one or more final judgments aggregating in excess of \$5,000,000 (to the extent not covered by insurance), which judgments are not discharged or effectively waived or stayed for a period of 45 consecutive days, or any action shall be legally taken by a judgment creditor to levy upon assets or properties of the Borrower or any Material Subsidiary to enforce any such judgment;

(k) (i) an ERISA Event or ERISA Events shall have occurred with respect to any Plan or Multiemployer Plan, (ii) the PBGC shall institute proceedings (including giving notice of intent thereof) to terminate any Plan or Plans, (iii) the Borrower or any Subsidiary or any ERISA Affiliate shall have been notified by the sponsor of a Multiemployer Plan that such Multiemployer Plan is in reorganization or is being terminated, within the meaning of Title IV of ERISA, or (iv) the Borrower or any Subsidiary shall engage in any "prohibited transaction" (as defined in Section 406 of ERISA or Section 4975 of the Code) involving any Plan; and in each case in clauses (i) through (iv) above, such event or condition, together with all other such events or conditions, if any, would reasonably be expected to have a Material Adverse Effect; or

(l) (i) any Loan Document shall for any reason be asserted in writing by Holdings (prior to a Qualified IPO of the Borrower), the Borrower or any Subsidiary Loan Party not to be a legal, valid and binding obligation of any party thereto, (ii) any security interest purported to be created by any Security Document and to extend to assets that constitute a material portion of the Collateral shall cease to be, or shall be asserted in writing by the Borrower or any other Loan Party not to be, a valid and perfected security interest (perfected as or having the priority required by this Agreement or the relevant Security Document and subject to such limitations and restrictions as are set forth herein and therein) in the securities, assets or properties covered thereby, except to the extent that any such loss of perfection or priority results from the limitations of foreign laws, rules and regulations as they apply to pledges of Equity Interests in Foreign Subsidiaries or the application thereof, or from the failure of the Collateral Agent to maintain possession of certificates actually delivered to it representing securities pledged under the Collateral Agreement or to file Uniform Commercial Code continuation statements or take the actions described on Schedule 3.04 and except to the extent that such loss is covered by a lender's title insurance policy and the Collateral Agent shall be reasonably satisfied with the credit of such insurer, or (iii) a material portion of the Guarantees pursuant to the Security Documents by Holdings (prior to a Qualified IPO of the Borrower) or the Subsidiary Loan Parties guaranteeing the Obligations shall cease to be in full force and effect (other than in accordance with the terms thereof), or shall be asserted in writing by Holdings (prior to a Qualified IPO of the Borrower) or any Subsidiary Loan Party not to be in effect or not to be legal, valid and binding obligations (other than in accordance with the terms thereof); provided, that no Event of Default shall occur under this Section 7.01(l) if the Loan Parties cooperate with the Collateral Agent to replace or perfect such security interest and Lien, such security interest and Lien is replaced and the rights, powers and privileges of the Secured Parties are not materially adversely affected by such replacement;

then, and in every such event (other than an event with respect to the Borrower described in clause (h) or (i) above), and at any time thereafter during the continuance of such event, the Administrative Agent, at the request of the Required Lenders, shall, by notice to the Borrower, take any or all of the following actions, at the same or different times: (i) terminate forthwith the Commitments, (ii) declare the Loans then outstanding to be forthwith due and payable in whole or in part, whereupon the principal of the Loans so declared to be due and payable, together with

accrued interest thereon and any unpaid accrued Fees and all other liabilities of the Borrower accrued hereunder and under any other Loan Document, shall become forthwith due and payable, without presentment, demand, protest or any other notice of any kind, all of which are hereby expressly waived by the Borrower, anything contained herein or in any other Loan Document to the contrary notwithstanding and (iii) if the Loans have been declared due and payable pursuant to clause (ii) above, demand Cash Collateral pursuant to Section 2.05(j); and in any event with respect to the Borrower described in clause (h) or (i) above, the Commitments shall automatically terminate and the principal of the Loans then outstanding, together with accrued interest thereon and any unpaid accrued Fees and all other liabilities of the Borrower accrued hereunder and under any other Loan Document, shall automatically become due and payable and the Administrative Agent shall be deemed to have made a demand for Cash Collateral to the full extent permitted under Section 2.05(j), without presentment, demand, protest or any other notice of any kind, all of which are hereby expressly waived by the Borrower, anything contained herein or in any other Loan Document to the contrary notwithstanding.

Section 7.02 Right to Cure. Notwithstanding anything to the contrary contained in Section 7.01, in the event that the Borrower fails (or, but for the operation of this Section 7.02, would fail) to comply with the requirements of the Financial Performance Covenant, until the expiration of the 10th Business Day subsequent to the date the certificate calculating such Financial Performance Covenant is required to be delivered pursuant to Section 5.04(c), the Borrower shall have the right to issue Permitted Cure Securities for cash or otherwise receive cash contributions (collectively, the "Cure Right"), and upon the receipt by the Borrower of such cash (the "Cure Amount") pursuant to the exercise by the Borrower of such Cure Right such Financial Performance Covenant shall be recalculated giving effect to a pro forma adjustment by which EBITDAR shall be increased with respect to such applicable quarter (and, for the avoidance of doubt, no effect shall be given to any pro forma reduction to Indebtedness for such applicable quarter resulting from the repayment thereof with the proceeds of such Permitted Cure Securities) and any four-quarter period that contains such quarter, solely for the purpose of measuring the Financial Performance Covenant and not for any other purpose under this Agreement, by an amount equal to the Cure Amount; provided, that (i) in each four consecutive fiscal quarter period there shall be at least two fiscal quarters in which the Cure Right is not exercised, (ii) the Cure Right shall not be exercised more than five times and (iii) for purposes of this Section 7.02, the Cure Amount shall be no greater than the amount required for purposes of complying with the Financial Performance Covenant. If, after giving effect to the adjustments in this Section 7.02, the Borrower shall then be in compliance with the requirements of the Financial Performance Covenant, the Borrower shall be deemed to have satisfied the requirements of the Financial Performance Covenant as of the relevant date of determination with the same effect as though there had been no failure to comply therewith at such date, and the applicable breach or default of the Financial Performance Covenant that had occurred shall be deemed cured for the purposes of this Agreement.

Section 7.03 Treatment of Certain Payments. Any amount received by the Administrative Agent or the Collateral Agent from any Loan Party (or from proceeds of any Collateral) following any acceleration of the Obligations under this Agreement or any Event of Default with respect to the Borrower under Section 7.01(h) or (i), in each case that is continuing, shall be applied in accordance with clauses first through ninth in Section 2.18(b).

ARTICLE VIII

*The Agents*

Section 8.01 Appointment. (a) Each Lender (in its capacities as a Lender and the Swingline Lender (if applicable) and on behalf of itself and its Affiliates as potential counterparties to Secured Cash Management Agreements and Secured Hedge Agreements) and each Issuing Bank (in such capacities and on behalf of itself and its Affiliates as potential counterparties to Secured Cash Management Agreements and Secured Hedge Agreements) hereby irrevocably designates and appoints the Administrative Agent as the agent of such Lender under this Agreement and the other Loan Documents, including as the Collateral Agent for such Lender and the other Secured Parties under the Security Documents, and each such Lender irrevocably authorizes the Administrative Agent, in such capacity, to take such action on its behalf under the provisions of this Agreement and the other Loan Documents and to exercise such powers and perform such duties as are expressly delegated to the Administrative Agent by the terms of this Agreement and the other Loan Documents, together with such other powers as are reasonably incidental thereto. In addition, to the extent required under the laws of any jurisdiction other than the United States of America, each of the Lenders and the Issuing Banks hereby grants to the Administrative Agent any required powers of attorney to execute any Security Document governed by the laws of such jurisdiction on such Lender's or Issuing Bank's behalf. Notwithstanding any provision to the contrary elsewhere in this Agreement, the Administrative Agent shall not have any duties or responsibilities, except those expressly set forth herein, or any fiduciary relationship with any Lender, and no implied covenants, functions, responsibilities, duties, obligations or liabilities shall be read into this Agreement or any other Loan Document or otherwise exist against the Administrative Agent .

(b) In furtherance of the foregoing, each Lender (in its capacities as a Lender and the Swingline Lender (if applicable) and on behalf of itself and its Affiliates as potential counterparties to Secured Cash Management Agreements or Secured Hedge Agreements) and each Issuing Bank (in such capacities and on behalf of itself and its Affiliates as potential counterparties to Secured Cash Management Agreements and Secured Hedge Agreements) hereby appoints and authorizes the Collateral Agent to act as the agent of such Lender for purposes of acquiring, holding and enforcing any and all Liens on Collateral granted by any of the Loan Parties to secure any of the Obligations, together with such powers and discretion as are reasonably incidental thereto. In this connection, the Collateral Agent (and any Subagents appointed by the Collateral Agent pursuant to Section 8.02 for purposes of holding or enforcing any Lien on the Collateral (or any portion thereof) granted under the Security Documents, or for exercising any rights or remedies thereunder at the direction of the Collateral Agent) shall be entitled to the benefits of this Article VIII (including, without limitation, Section 8.07) as though the Collateral Agent (and any such Subagents) were an "Agent" under the Loan Documents, as if set forth in full herein with respect thereto.

Section 8.02 Delegation of Duties. The Administrative Agent and the Collateral Agent may execute any of their respective duties under this Agreement and the other Loan Documents (including for purposes of holding or enforcing any Lien on the Collateral (or any portion thereof)) by or through agents, employees or attorneys-in-fact and shall be entitled to advice of counsel and other consultants or experts concerning all matters pertaining to such duties. No Agent shall be responsible for the negligence or misconduct of any agents or attorneys-in-fact selected by it with reasonable care. Each Agent may also from time to time, when it deems it to be necessary or desirable, appoint one or more trustees, co-trustees, collateral co-agents, collateral subagents or attorneys-in-fact (each, a "Subagent") with respect to all or any part of the Collateral; provided, that no such Subagent shall be authorized to take any action with respect to any Collateral unless and except to the extent expressly authorized in writing by the Administrative Agent or the Collateral Agent. Should any instrument in writing from the Borrower or any other Loan Party be required by any Subagent so appointed by an Agent to more fully or certainly vest in and confirm to such Subagent such rights, powers, privileges and duties, the Borrower shall, or shall cause such Loan Party to, execute, acknowledge and deliver any and all such instruments promptly upon request by such Agent. If any Subagent, or successor thereto, shall become incapable of acting, resign or be removed, all rights, powers, privileges and duties of such Subagent, to the extent permitted by law, shall automatically vest in and be exercised by the Administrative Agent or the Collateral Agent until the appointment of a new Subagent. No Agent shall be responsible for the negligence or misconduct of any agent, attorney-in-fact or Subagent that it selects with reasonable care.

Section 8.03 Exculpatory Provisions. None of the Agents, or their respective Affiliates or any of their respective officers, directors, employees, agents, attorneys-in-fact or affiliates shall be (a) liable for any action lawfully taken or omitted to be taken by it or such person under or in connection with this Agreement or any other Loan Document (except to the extent that any of the foregoing are found by a final and nonappealable decision of a court of competent jurisdiction to have resulted from its or such person's own gross negligence or willful misconduct) or (b) responsible in any manner to any of the Lenders for any recitals, statements, representations or warranties made by any Loan Party or any officer thereof contained in this Agreement or any other Loan Document or in any certificate, report, statement or other document referred to or provided for in, or received by the Agents under or in connection with, this Agreement or any other Loan Document or for the value, validity, effectiveness, genuineness, enforceability or sufficiency of this Agreement or any other Loan Document or for any failure of any Loan Party a party thereto to perform its obligations hereunder or thereunder. The Agents shall not be under any obligation to any Lender to ascertain or to inquire as to the observance or performance of any of the agreements contained in, or conditions of, this Agreement or any other Loan Document, or to inspect the properties, books or records of any Loan Party. The Administrative Agent shall not have any duties or obligations except those expressly set forth herein and in the other Loan Documents. Without limiting the generality of the foregoing, (a) the Administrative Agent shall not be subject to any fiduciary or other implied duties, regardless of whether a Default or Event of Default has occurred and is continuing, and (b) the Administrative Agent shall not, except as expressly set forth herein and in the other Loan Documents, have any duty to disclose, and shall not be liable for the failure to disclose, any information relating to the Borrower or any of its Affiliates that is communicated to or obtained by the person serving as the Administrative Agent or any of its Affiliates in any capacity. The



Administrative Agent shall be deemed not to have knowledge of any Default or Event of Default unless and until written notice describing such Default or Event of Default is given to the Administrative Agent by the Borrower, a Lender or an Issuing Bank. The Administrative Agent shall not be responsible for or have any duty to ascertain or inquire into (i) any statement, warranty or representation made in or in connection with this Agreement or any other Loan Document, (ii) the contents of any certificate, report or other document delivered hereunder or thereunder or in connection herewith or therewith, (iii) the performance or observance of any of the covenants, agreements or other terms or conditions set forth herein or therein or the occurrence of any Default or Event of Default, (iv) the validity, enforceability, effectiveness or genuineness of this Agreement, any other Loan Document or any other agreement, instrument or document, or the creation, perfection or priority of any Lien purported to be created by the Security Documents, (v) the value or the sufficiency of any Collateral, or (vi) the satisfaction of any condition set forth in Article IV or elsewhere herein, other than to confirm receipt of items expressly required to be delivered to the Administrative Agent.

Section 8.04 Reliance by Agents. Each Agent shall be entitled to rely upon, and shall not incur any liability for relying upon, any notice, request, certificate, consent, statement, instrument, document or other writing (including any electronic message, Internet or intranet website posting or other distribution) or conversation believed by it to be genuine and to have been signed, sent or otherwise authenticated by the proper person. Each Agent also may rely upon any statement made to it orally or by telephone and believed by it to have been made by the proper person, and shall not incur any liability for relying thereon. In determining compliance with any condition hereunder to any Credit Event, that by its terms must be fulfilled to the satisfaction of a Lender or any Issuing Bank, each Agent may presume that such condition is satisfactory to such Lender or Issuing Bank unless such Agent shall have received notice to the contrary from such Lender or Issuing Bank prior to such Credit Event. Each Agent may consult with legal counsel (including counsel to Holdings or the Borrower), independent accountants and other experts selected by it, and shall not be liable for any action taken or not taken by it in accordance with the advice of any such counsel, accountants or experts. Each Agent may deem and treat the payee of any Note as the owner thereof for all purposes unless a written notice of assignment, negotiation or transfer thereof shall have been filed with such Agent. Each Agent shall be fully justified in failing or refusing to take any action under this Agreement or any other Loan Document unless it shall first receive such advice or concurrence of the Required Lenders (or, if so specified by this Agreement, all or other Lenders) as it deems appropriate or it shall first be indemnified to its satisfaction by the Lenders against any and all liability and expense that may be incurred by it by reason of taking or continuing to take any such action. Each Agent shall in all cases be fully protected in acting, or in refraining from acting, under this Agreement and the other Loan Documents in accordance with a request of the Required Lenders (or, if so specified by this Agreement, all or other Lenders), and such request and any action taken or failure to act pursuant thereto shall be binding upon all the Lenders and all future holders of the Loans.

Section 8.05 Notice of Default. Neither Agent shall be deemed to have knowledge or notice of the occurrence of any Default or Event of Default unless such Agent has received written notice from a Lender, Holdings or the Borrower referring to this Agreement, describing such Default or Event of Default and stating that such notice is a “notice of default.”

In the event that the Administrative Agent receives such a notice, the Administrative Agent shall give notice thereof to the Lenders. The Administrative Agent shall take such action with respect to such Default or Event of Default as shall be reasonably directed by the Required Lenders (or, if so specified by this Agreement, all or other Lenders); provided, that unless and until the Administrative Agent shall have received such directions, the Administrative Agent may (but shall not be obligated to) take such action, or refrain from taking such action, with respect to such Default or Event of Default as it shall deem advisable in the best interests of the Lenders.

Section 8.06 Non-Reliance on Agents and Other Lenders. Each Lender expressly acknowledges that neither the Agents nor any of their respective officers, directors, employees, agents, attorneys-in-fact or affiliates have made any representations or warranties to it and that no act by any Agent hereafter taken, including any review of the affairs of a Loan Party or any affiliate of a Loan Party, shall be deemed to constitute any representation or warranty by any Agent to any Lender. Each Lender represents to the Agents that it has, independently and without reliance upon any Agent or any other Lender, and based on such documents and information as it has deemed appropriate, made its own appraisal of, and investigation into, the business, operations, property, financial and other condition and creditworthiness of the Loan Parties and their affiliates and made its own decision to make its Loans hereunder and enter into this Agreement. Each Lender also represents that it will, independently and without reliance upon any Agent or any other Lender, and based on such documents and information as it shall deem appropriate at the time, continue to make its own credit analysis, appraisals and decisions in taking or not taking action under this Agreement and the other Loan Documents, and to make such investigation as it deems necessary to inform itself as to the business, operations, property, financial and other condition and creditworthiness of the Loan Parties and their affiliates. Except for notices, reports and other documents expressly required to be furnished to the Lenders by the Administrative Agent hereunder, the Administrative Agent shall not have any duty or responsibility to provide any Lender with any credit or other information concerning the business, operations, property, condition (financial or otherwise), prospects or creditworthiness of any Loan Party or any affiliate of a Loan Party that may come into the possession of the Administrative Agent or any of its officers, directors, employees, agents, attorneys-in-fact or affiliates.

Section 8.07 Indemnification. The Lenders agree to indemnify each Agent and each Issuing Bank, in each case in its capacity as such (to the extent not reimbursed by Holdings or the Borrower and without limiting the obligation of such person to do so), in the amount of its pro rata share (based on its aggregate Revolving Facility Credit Exposure and unused Commitments hereunder; provided, that the aggregate principal amount of L/C Disbursements owing to any Issuing Bank thereunder and the aggregate principal amount of Swingline Loans owing to the Swingline Lender shall be considered to be owed to the Revolving Lenders ratably in accordance with their respective Revolving Facility Credit Exposure) (determined at the time such indemnity is sought), from and against any and all liabilities, obligations, losses, damages, penalties, actions, judgments, suits, costs, expenses or disbursements of any kind whatsoever that may at any time (whether before or after the payment of the Loans) be imposed on, incurred by or asserted against such Agent or such Issuing Bank in any way relating to or arising out of the Commitments, this Agreement, any of the other Loan Documents or any documents contemplated by or referred to herein or therein or the transactions contemplated hereby or

thereby or any action taken or omitted by such Agent or such Issuing Bank under or in connection with any of the foregoing; provided, that no Lender shall be liable for the payment of any portion of such liabilities, obligations, losses, damages, penalties, actions, judgments, suits, costs, expenses or disbursements that are found by a final and nonappealable decision of a court of competent jurisdiction to have resulted from such Agent's or such Issuing Bank's gross negligence or willful misconduct. The failure of any Lender to reimburse any Agent or any Issuing Bank, as the case may be, promptly upon demand for its ratable share of any amount required to be paid by the Lenders to such Agent or such Issuing Bank, as the case may be, as provided herein shall not relieve any other Lender of its obligation hereunder to reimburse such Agent or such Issuing Bank, as the case may be, for its ratable share of such amount, but no Lender shall be responsible for the failure of any other Lender to reimburse such Agent or such Issuing Bank, as the case may be, for such other Lender's ratable share of such amount. The agreements in this Section shall survive the payment of the Loans and all other amounts payable hereunder.

Section 8.08 Agent in Its Individual Capacity. Each Agent and its affiliates may make loans to, accept deposits from, and generally engage in any kind of business with any Loan Party as though such Agent were not an Agent. With respect to its Loans made or renewed by it and with respect to any Letter of Credit issued, or Letter of Credit or Swingline Loan participated in, by it, each Agent shall have the same rights and powers under this Agreement and the other Loan Documents as any Lender and may exercise the same as though it were not an Agent, and the terms "Lender" and "Lenders" shall include each Agent in its individual capacity.

Section 8.09 Successor Administrative Agent. The Administrative Agent may resign as Administrative Agent and Collateral Agent upon 10 days' notice to the Lenders and the Borrower. If the Administrative Agent shall resign as Administrative Agent and Collateral Agent under this Agreement and the other Loan Documents, then the Required Lenders shall appoint from among the Lenders a successor agent for the Lenders, which successor agent shall (unless an Event of Default under Section 7.01(b), (c), (h) or (i) shall have occurred and be continuing) be subject to approval by the Borrower (which approval shall not be unreasonably withheld or delayed), whereupon such successor agent shall succeed to the rights, powers and duties of the Administrative Agent and Collateral Agent, and the term "Administrative Agent" shall mean such successor agent effective upon such appointment and approval, and the former Administrative Agent's rights, powers and duties as Administrative Agent shall be terminated, without any other or further act or deed on the part of such former Administrative Agent or any of the parties to this Agreement or any holders of the Loans. If no successor agent has accepted appointment as Administrative Agent by the date that is 10 days following a retiring Administrative Agent's notice of resignation, the retiring Administrative Agent's resignation shall nevertheless thereupon become effective, and the Lenders shall assume and perform all of the duties of the Administrative Agent and Collateral Agent hereunder until such time, if any, as the Required Lenders appoint a successor agent as provided for above. After any retiring Administrative Agent's resignation as Administrative Agent, the provisions of this Section 8.09 shall inure to its benefit as to any actions taken or omitted to be taken by it while it was Administrative Agent under this Agreement and the other Loan Documents.

Section 8.10 Arranger and Syndication Agent. Notwithstanding any other provision of this Agreement or any provision of any other Loan Document, each of the persons named on the cover page hereof as Bookrunner, Lead Arranger or Syndication Agent is named as such for recognition purposes only, and in its capacity as such shall have no rights, duties, responsibilities or liabilities with respect to this Agreement or any other Loan Document, except that each such person and its Affiliates shall be entitled to the rights expressly stated to be applicable to them in Sections 9.05 and 9.17 (subject to the applicable obligations and limitations as set forth therein).

Section 8.11 Security Documents and Collateral Agent Under Security Documents and Guarantees. The Lenders authorize the Collateral Agent to release any Collateral or Guarantors in accordance with Section 9.18.

The Lenders hereby irrevocably authorize and instruct the Collateral Agent to, without any further consent of any Lender, enter into (or acknowledge and consent to) or amend, renew, extend, supplement, restate, replace, waive or otherwise modify any Permitted Intercreditor Agreement or any other intercreditor agreement with the collateral agent or other representatives of the holders of Indebtedness that is permitted to be secured by a Lien on the Collateral that is permitted (including with respect to priority) under this Agreement and to subject the Liens on the Collateral securing the Obligations to the provisions thereof. The Lenders and the other Secured Parties by acceptance of the security granted under the Security Documents irrevocably agree that (x) the Collateral Agent may rely exclusively on a certificate of a Responsible Officer of the Borrower as to whether any such other Liens are permitted and (y) any intercreditor agreement referred to in the foregoing sentence, entered into by the Collateral Agent, shall be binding on the Secured Parties, and each Lender and each other Secured Party by acceptance of the security granted under the Security Documents hereby agrees that it will take no actions contrary to the provisions of, if entered into and if applicable, any Permitted Intercreditor Agreement. The foregoing provisions are intended as an inducement to any provider of any Indebtedness not prohibited by Section 6.01 hereof to extend credit to the Loan Parties and such persons are intended third-party beneficiaries of such provisions. Furthermore, the Lenders (including in their capacities as potential Cash Management Banks and potential Hedge Banks) and the other Secured Parties by acceptance of the security granted under the Security Documents hereby authorize the Administrative Agent and the Collateral Agent to release any Lien on any property granted to or held by the Administrative Agent or the Collateral Agent under any Loan Document (i) to the holder of any Lien on such property that is permitted by clauses (c), (i), (j), (ii) and (II) of Section 6.02 or Section 6.02(a) (if the Liens thereunder are of a type that is contemplated by any of the foregoing clauses) in each case to the extent the contract or agreement pursuant to which such Lien is granted prohibits any other Liens on such property or (ii) that is or becomes Excluded Property, and the Administrative Agent and the Collateral Agent shall do so upon request of the Borrower; provided, that prior to any such request, the Borrower shall have in each case delivered to the Administrative Agent a certificate of a Responsible Officer of the Borrower certifying (x) that such Lien is permitted under this Agreement, (y) in the case of a request pursuant to clause (i) of this sentence, that the contract or agreement pursuant to which such Lien is granted prohibits any other Lien on such property and (z) in the case of a request pursuant to clause (ii) of this sentence, that (A) such property is or has become Excluded Property and (B) if such property has become Excluded Property as a result of

a contractual restriction, such restriction does not violate Section 6.09(c) and, if any restriction referred to in this clause (B) relates to property other than cash, Permitted Investments or joint venture interests, such restriction either existed at the time such property was acquired (and was not created in contemplation of such acquisition) or was permitted by Section 6.09(c)(Q).

Section 8.12 Right to Realize on Collateral and Enforce Guarantees. In case of the pendency of any receivership, insolvency, liquidation, bankruptcy, reorganization, arrangement, adjustment, composition or other judicial proceeding relative to any Loan Party, (i) the Administrative Agent (irrespective of whether the principal of any Obligation shall then be due and payable as herein expressed or by declaration or otherwise and irrespective of whether the Administrative Agent shall have made any demand on the Borrower) shall be entitled and empowered, by intervention in such proceeding or otherwise (A) to file and prove a claim for the whole amount of the principal and interest owing and unpaid in respect of any or all of the Obligations that are owing and unpaid and to file such other documents as may be necessary or advisable in order to have the claims of the Lenders and the Administrative Agent and any Subagents allowed in such judicial proceeding, and (B) to collect and receive any monies or other property payable or deliverable on any such claims and to distribute the same, and (ii) any custodian, receiver, assignee, trustee, liquidator, sequestrator or other similar official in any such judicial proceeding is hereby authorized by each Lender to make such payments to the Administrative Agent and, if the Administrative Agent shall consent to the making of such payments directly to the Lenders, to pay to the Administrative Agent any amount due for the reasonable compensation, expenses, disbursements and advances of the Administrative Agent and its agents and counsel, and any other amounts due the Administrative Agent under the Loan Documents. Nothing contained herein shall be deemed to authorize the Administrative Agent to authorize or consent to or accept or adopt on behalf of any Lender any plan of reorganization, arrangement, adjustment or composition affecting the Obligations or the rights of any Lender or to authorize the Administrative Agent to vote in respect of the claim of any Lender in any such proceeding.

Anything contained in any of the Loan Documents to the contrary notwithstanding, the Borrower, the Administrative Agent, the Collateral Agent and each Secured Party hereby agree that (a) no Secured Party shall have any right individually to realize upon any of the Collateral or to enforce the Guarantee, it being understood and agreed that all powers, rights and remedies hereunder may be exercised solely by the Administrative Agent, on behalf of the Secured Parties in accordance with the terms hereof and all powers, rights and remedies under the Security Documents may be exercised solely by the Collateral Agent, and (b) in the event of a foreclosure by the Collateral Agent on any of the Collateral pursuant to a public or private sale or other disposition, the Collateral Agent or any Lender may be the purchaser or licensor of any or all of such Collateral at any such sale or other disposition and the Collateral Agent, as agent for and representative of the Secured Parties (but not any Lender or Lenders in its or their respective individual capacities unless the Required Lenders shall otherwise agree in writing) shall be entitled, for the purpose of bidding and making settlement or payment of the purchase price for all or any portion of the Collateral sold at any such public sale, to use and apply any of the Obligations as a credit on account of the purchase price for any collateral payable by the Collateral Agent at such sale or other Disposition.

Section 8.13 Secured Hedge Obligations. (a) The Borrower and any Hedge Bank (the “Secured Hedge Counterparty”) may from time to time designate the Hedging Agreement to which they are parties as being a “Secured Hedge Agreement” upon written notice (a “Designation Notice”) to the Administrative Agent from the Borrower and the Secured Hedge Counterparty, in form reasonably acceptable to the Administrative Agent, which Designation Notice shall include (i) a description of such Hedging Agreement and (ii) the maximum amount (expressed in Dollars) of the Hedge Termination Value thereunder, if any, that is elected by the Borrower and the Secured Hedge Counterparty to constitute “Pari Passu Secured Hedge Obligations” and as to which an equal Reserve shall be taken against the Borrowing Base (each, a “Designated Pari Passu Amount”) and the Obligations under such Secured Hedge Agreement (to the extent of such Designated Pari Passu Amount), “Pari Passu Secured Hedge Obligations”); provided that no such Designation Notice shall be effective and no such Designated Pari Passu Amount with respect to any Hedging Agreement shall constitute Pari Passu Secured Hedge Obligations (and no such Reserve shall be established by the Administrative Agent in connection therewith) to the extent that, at the time of delivery of the applicable Designation Notice and after giving effect to such Designated Pari Passu Amount (including to the Reserve for Pari Passu Secured Hedge Obligations to be established by the Administrative Agent in connection therewith), the Availability would be less than zero.

(b) The Borrower and the applicable Secured Hedge Counterparty may increase, decrease or terminate any Designated Pari Passu Amount in respect of a Hedging Agreement upon written notice to the Administrative Agent, in which case the Administrative Agent shall promptly make a corresponding adjustment to the reserve against the Borrowing Base with respect thereto; provided that any increase in a Designated Pari Passu Amount shall be deemed to be a new designation of a Designated Pari Passu Amount pursuant to a new Designation Notice and shall be subject to the limitations set forth in Section 8.13(a). For the avoidance of doubt, Obligations under any Hedging Agreement designated pursuant to this Section 8.13 in excess of the applicable Designated Pari Passu Amount shall constitute Obligations under a Secured Hedge Agreement but shall be entitled to a lesser priority of payment as set forth in Section 2.18(b).

Section 8.14 Withholding Tax. To the extent required by any applicable Requirement of Law, the Administrative Agent may withhold from any payment to any Lender an amount equivalent to any applicable withholding Tax. If the Internal Revenue Service or any authority of the United States or other jurisdiction asserts a claim that the Administrative Agent did not properly withhold Tax from amounts paid to or for the account of any Lender for any reason (including because the appropriate form was not delivered, was not properly executed, or because such Lender failed to notify the Administrative Agent of a change in circumstances that rendered the exemption from, or reduction of, withholding Tax ineffective), such Lender shall indemnify the Administrative Agent (to the extent that the Administrative Agent has not already been reimbursed by any applicable Loan Party and without limiting the obligation of any applicable Loan Party to do so) fully for all amounts paid, directly or indirectly, by the Administrative Agent as Tax or otherwise, including penalties, fines, additions to Tax and interest, together with all expenses incurred, including legal expenses, allocated staff costs and any out of pocket expenses. Each Lender hereby authorizes the Administrative Agent to set off and apply any and all amounts at any time owing to such Lender under this Agreement or any other Loan Document against any amount due to the Administrative Agent under this Section 8.14.

Section 8.15 Certain ERISA Matters. (a) Each Lender (x) represents and warrants, as of the date such person became a Lender party hereto, to, and (y) covenants, from the date such person became a Lender party hereto to the date such person ceases being a Lender party hereto, for the benefit of, the Administrative Agent and the Arranger and their respective Affiliates, and not, for the avoidance of doubt, to or for the benefit of the Borrower or any other Loan Party, that at least one of the following is and will be true:

(i) such Lender is not using “plan assets” (within the meaning of 29 CFR § 2510.3-101, as modified by Section 3(42) of ERISA) of one or more Benefit Plans in connection with the Loans, the Letters of Credit or the Commitments,

(ii) the transaction exemption set forth in one or more PTEs, such as PTE 84-14 (a class exemption for certain transactions determined by independent qualified professional asset managers), PTE 95-60 (a class exemption for certain transactions involving insurance company general accounts), PTE 90-1 (a class exemption for certain transactions involving insurance company pooled separate accounts), PTE 91-38 (a class exemption for certain transactions involving bank collective investment funds) or PTE 96-23 (a class exemption for certain transactions determined by in-house asset managers), is applicable with respect to such Lender’s entrance into, participation in, administration of and performance of the Loans, the Letters of Credit, the Commitments and this Agreement,

(iii) (A) such Lender is an investment fund managed by a “Qualified Professional Asset Manager” (within the meaning of Part VI of PTE 84-14), (B) such Qualified Professional Asset Manager made the investment decision on behalf of such Lender to enter into, participate in, administer and perform the Loans, the Letters of Credit, the Commitments and this Agreement, (C) the entrance into, participation in, administration of and performance of the Loans, the Letters of Credit, the Commitments and this Agreement satisfies the requirements of sub-sections (b) through (g) of Part I of PTE 84-14 and (D) to the best knowledge of such Lender, the requirements of subsection (a) of Part I of PTE 84-14 are satisfied with respect to such Lender’s entrance into, participation in, administration of and performance of the Loans, the Letters of Credit, the Commitments and this Agreement, or

(iv) such other representation, warranty and covenant as may be agreed in writing between the Administrative Agent, in its sole discretion, and such Lender.

(b) In addition, (I) unless sub-clause (i) in the immediately preceding clause (a) is true with respect to a Lender or (II) if such sub-clause (i) is not true with respect to a Lender and such Lender has not provided another representation, warranty and covenant as provided in sub-clause (iv) in the immediately preceding clause (a), such Lender further (x) represents and warrants, as of the date such person became a Lender party hereto, to, and (y) covenants, from the date such person became a Lender party hereto to the date such person ceases being a Lender party hereto, for the benefit of, the Administrative Agent and the Arranger and their respective Affiliates, and not, for the avoidance of doubt, to or for the benefit of the Borrower or any other Loan Party, that:

(i) none of the Administrative Agent or the Arranger or any of their respective Affiliates is a fiduciary with respect to the assets of such Lender (including in connection with the reservation or exercise of any rights by the Administrative Agent under this Agreement, any Loan Document or any documents related hereto or thereto),

(ii) the person making the investment decision on behalf of such Lender with respect to the entrance into, participation in, administration of and performance of the Loans, the Letters of Credit, the Commitments and this Agreement is independent (within the meaning of 29 CFR § 2510.3-21) and is a bank, an insurance carrier, an investment adviser, a broker-dealer or other person that holds, or has under management or control, total assets of at least \$50 million, in each case as described in 29 CFR § 2510.3-21(c)(1)(i)(A)-(E),

(iii) the person making the investment decision on behalf of such Lender with respect to the entrance into, participation in, administration of and performance of the Loans, the Letters of Credit, the Commitments and this Agreement is capable of evaluating investment risks independently, both in general and with regard to particular transactions and investment strategies (including in respect of the Obligations),

(iv) the person making the investment decision on behalf of such Lender with respect to the entrance into, participation in, administration of and performance of the Loans, the Letters of Credit, the Commitments and this Agreement is a fiduciary under ERISA or the Code, or both, with respect to the Loans, the Letters of Credit, the Commitments and this Agreement and is responsible for exercising independent judgment in evaluating the transactions hereunder, and

(v) no fee or other compensation is being paid directly to the Administrative Agent or the Arranger or any of their respective Affiliates for investment advice (as opposed to other services) in connection with the Loans, the Letters of Credit, the Commitments or this Agreement.

(c) The Administrative Agent and the Arranger hereby informs the Lenders that each such person is not undertaking to provide impartial investment advice, or to give advice in a fiduciary capacity, in connection with the transactions contemplated hereby, and that such person has a financial interest in the transactions contemplated hereby in that such person or an Affiliate thereof (i) may receive interest or other payments with respect to the Loans, the Letters of Credit, the Commitments and this Agreement, (ii) may recognize a gain if it extended the Loans, the Letters of Credit or the Commitments for an amount less than the amount being paid for an interest in the Loans, the Letters of Credit or the Commitments by such Lender or (iii) may receive fees or other payments in connection with the transactions contemplated hereby, the Loan Documents or otherwise, including structuring fees, commitment fees, arrangement fees, facility fees, upfront fees, underwriting fees, ticking fees, agency fees, administrative agent or collateral agent fees, utilization fees, minimum usage fees, letter of credit fees, fronting fees, deal-away or alternate transaction fees, amendment fees, processing fees, term out premiums, banker's acceptance fees, breakage or other early termination fees or fees similar to the foregoing.



ARTICLE IX

*Miscellaneous*

Section 9.01 Notices; Communications. (a) Except in the case of notices and other communications expressly permitted to be given by telephone (and except as provided in Section 9.01(b) below), all notices and other communications provided for herein shall be in writing and shall be delivered by hand or overnight courier service, mailed by certified or registered mail or sent by facsimile or other electronic means as follows, and all notices and other communications expressly permitted hereunder to be given by telephone shall be made to the applicable telephone number, as follows:

(i) if to any Loan Party or the Administrative Agent, the Issuing Bank as of the Closing Date or the Swingline Lender, to the address, facsimile number, electronic mail address or telephone number specified for such person on Schedule 9.01; and

(ii) if to any other Lender or Issuing Bank, to the address, facsimile number, electronic mail address or telephone number specified in its Administrative Questionnaire.

(b) Notices and other communications to the Lenders and the Issuing Bank hereunder may be delivered or furnished by electronic communication (including electronic mail and Internet or intranet websites) pursuant to procedures approved by the Administrative Agent; provided, that the foregoing shall not apply to notices to any Lender or the Issuing Bank pursuant to Article II if such Lender or the Issuing Bank, as applicable, has notified the Administrative Agent that it is incapable of receiving notices under such Article by electronic communication. The Administrative Agent or the Borrower may, in their discretion, agree to accept notices and other communications to it hereunder by electronic communications pursuant to procedures approved by it; provided, that approval of such procedures may be limited to particular notices or communications.

(c) Notices sent by hand or overnight courier service, or mailed by certified or registered mail, shall be deemed to have been given when received. Notices sent by facsimile shall be deemed to have been given when sent (except that, if not given during normal business hours for the recipient, shall be deemed to have been given at the opening of business on the next Business Day for the recipient). Notices delivered through electronic communications to the extent provided in Section 9.01(b) above shall be effective as provided in such Section 9.01(b).

(d) Any party hereto may change its address or facsimile number for notices and other communications hereunder by notice to the other parties hereto.

(e) Documents required to be delivered pursuant to Section 5.04 (to the extent any such documents are included in materials otherwise filed with the SEC) may be delivered electronically (including as set forth in Section 9.17) and if so delivered, shall be deemed to have been delivered on the date (i) on which the Borrower posts such documents, or provides a link thereto, on the Borrower's website on the Internet at the website address listed on

Schedule 9.01, or (ii) on which such documents are posted on the Borrower's behalf on an Internet or intranet website, if any, to which each Lender and the Administrative Agent have access (whether a commercial, third-party website or whether sponsored by the Administrative Agent); provided, that (A) the Borrower shall deliver paper copies of such documents to the Administrative Agent or any Lender that requests the Borrower to deliver such paper copies until a written request to cease delivering paper copies is given by the Administrative Agent or such Lender, and (B) the Borrower shall notify the Administrative Agent (by facsimile or electronic mail) of the posting of any such documents and provide to the Administrative Agent by electronic mail electronic versions (i.e., soft copies) of such documents. Except for such certificates required by Section 5.04(c), the Administrative Agent shall have no obligation to request the delivery or to maintain copies of the documents referred to above, and in any event shall have no responsibility to monitor compliance by the Borrower with any such request for delivery, and each Lender shall be solely responsible for requesting delivery to it or maintaining its copies of such documents.

Section 9.02 Survival of Agreement. All covenants, agreements, representations and warranties made by the Loan Parties herein, in the other Loan Documents and in the certificates or other instruments prepared or delivered in connection with or pursuant to this Agreement or any other Loan Document shall be considered to have been relied upon by the Lenders and each Issuing Bank and shall survive the making by the Lenders of the Loans and the execution and delivery of the Loan Documents and the issuance of the Letters of Credit, regardless of any investigation made by such persons or on their behalf, and shall continue in full force and effect until the Termination Date. Without prejudice to the survival of any other agreements contained herein, indemnification and reimbursement obligations contained herein (including pursuant to Sections 2.15, 2.17 and 9.05) shall survive the payment in full of the principal and interest hereunder, the expiration of the Letters of Credit and the termination of the Commitments or this Agreement.

Section 9.03 Binding Effect. This Agreement shall become effective when it shall have been executed by Holdings and the Administrative Agent and when the Administrative Agent shall have received copies hereof which, when taken together, bear the signatures of each of the other parties hereto (and shall become effective with respect to the Borrower upon the Administrative Agent's receipt of the Borrower's joinder hereto), and thereafter shall be binding upon and inure to the benefit of Holdings, upon its joinder hereto, the Borrower, the Administrative Agent, each Issuing Bank and each Lender and their respective permitted successors and assigns.

Section 9.04 Successors and Assigns. (a) The provisions of this Agreement shall be binding upon and inure to the benefit of the parties hereto and their respective successors and assigns permitted hereby (including any Affiliate of an Issuing Bank that issues any Letter of Credit), except that (i) the Borrower may not assign or otherwise transfer any of its rights or obligations hereunder without the prior written consent of each Lender (and any attempted assignment or transfer by the Borrower without such consent shall be null and void) and (ii) no Lender may assign or otherwise transfer its rights or obligations hereunder except in accordance with this Section 9.04. Nothing in this Agreement, expressed or implied, shall be construed to confer upon any person (other than the parties hereto, their respective successors and assigns

permitted hereby (including any Affiliate of an Issuing Bank that issues any Letter of Credit), Participants (to the extent provided in clause (c) of this Section 9.04), and, to the extent expressly contemplated hereby, the Related Parties of each of the Agents, the Issuing Banks and the Lenders) any legal or equitable right, remedy or claim under or by reason of this Agreement or the other Loan Documents.

(b) (i) Subject to the conditions set forth in subclause (ii) below, any Lender may assign to one or more assignees (each, an “Assignee”) all or a portion of its rights and obligations under this Agreement (including all or a portion of its Commitments and the Loans at the time owing to it) with the prior written consent (such consent not to be unreasonably withheld or delayed) of:

(A) the Borrower, which consent will be deemed to have been given if the Borrower has not responded within ten (10) Business Days after its receipt of any request for such consent; provided, that no consent of the Borrower shall be required for an assignment to a Lender, an Affiliate of a Lender, an Approved Fund (as defined below), or in the case of assignments during the primary syndication of the Commitments and Loans to persons identified to and agreed by the Borrower in writing prior to the Closing Date, or, if an Event of Default under Section 7.01(b), (c), (h) or (i) has occurred and is continuing, any other person; and

(B) the Administrative Agent; provided, that no consent of the Administrative Agent shall be required for an assignment of all or any portion of a Loan or Commitment to a Lender, an Affiliate of a Lender or an Approved Fund; and

(C) the Swingline Lender and each Issuing Bank.

(ii) Assignments shall be subject to the following additional conditions:

(A) except in the case of an assignment to a Lender, an Affiliate of a Lender or an Approved Fund or an assignment of the entire remaining amount of the assigning Lender’s Commitments or Loans under any Facility, the amount of the Commitments or Loans of the assigning Lender subject to each such assignment (determined as of the date on which the Assignment and Acceptance with respect to such assignment is delivered to the Administrative Agent) shall not be less than \$1,000,000, unless each of the Borrower and the Administrative Agent otherwise consent; provided, that such amounts shall be aggregated in respect of each Lender and its Affiliates or Approved Funds (with simultaneous assignments to or by two or more Related Funds shall be treated as one assignment), if any;

(B) the parties to each assignment shall (1) execute and deliver to the Administrative Agent an Assignment and Acceptance via an electronic settlement system acceptable to the Administrative Agent or (2) if previously agreed with the Administrative Agent, manually execute and deliver to the Administrative Agent an Assignment and Acceptance, in each case together with a processing and recordation fee of \$3,500 (which fee may be waived or reduced in the discretion of the Administrative Agent);

(C) the Assignee, if it shall not be a Lender, shall deliver to the Administrative Agent an Administrative Questionnaire and any tax forms required to be delivered pursuant to Section 2.17; and

(D) the Assignee shall not be the Borrower or any of the Borrower's Affiliates or Subsidiaries.

For the purposes of this Section 9.04, "Approved Fund" means any person (other than a natural person) that is engaged in making, purchasing, holding or investing in bank loans and similar extensions of credit in the ordinary course and that is administered or managed by (a) a Lender, (b) an Affiliate of a Lender or (c) an entity or an Affiliate of an entity that administers or manages a Lender. Notwithstanding the foregoing or anything to the contrary herein, no Lender shall be permitted to assign or transfer any portion of its rights and obligations under this Agreement to (A) any Ineligible Institution, (B) any Defaulting Lender or any of the Subsidiaries, or any person who, upon becoming a Lender hereunder, would constitute any of the foregoing persons described in this clause (B), or (C) a natural person. Notwithstanding the foregoing, each Loan Party and the Lenders acknowledge and agree that the Administrative Agent shall not have any responsibility or obligation to determine whether any Lender or potential Lender is an Ineligible Institution and the Administrative Agent shall have no liability with respect to any assignment made to an Ineligible Institution. Any assigning Lender shall, in connection with any potential assignment, provide to the Borrower a copy of its request (including the name of the prospective assignee) concurrently with its delivery of the same request to the Administrative Agent irrespective of whether or not an Event of Default under Section 7.01(b), (c), (h) or (i) has occurred and is continuing.

(iii) Subject to acceptance and recording thereof pursuant to subclause (v) below, from and after the effective date specified in each Assignment and Acceptance the Assignee thereunder shall be a party hereto and, to the extent of the interest assigned by such Assignment and Acceptance, have the rights and obligations of a Lender under this Agreement, and the assigning Lender thereunder shall, to the extent of the interest assigned by such Assignment and Acceptance, be released from its obligations under this Agreement (and, in the case of an Assignment and Acceptance covering all of the assigning Lender's rights and obligations under this Agreement, such Lender shall cease to be a party hereto but shall continue to be entitled to the benefits of Sections 2.15, 2.16, 2.17 and 9.05 (subject to the limitations and requirements of those Sections)); provided, that an Assignee shall not be entitled to receive any greater payment pursuant to Section 2.17 than the applicable Assignor would have been entitled to receive had no such assignment occurred. Any assignment or transfer by a Lender of rights or obligations under this Agreement that does not comply with this Section 9.04 shall be treated for purposes of this Agreement as a sale by such Lender of a participation in such rights and obligations in accordance with clause (c) of this Section 9.04.

(iv) The Administrative Agent, acting solely for this purpose as a non-fiduciary agent of the Borrower, shall maintain at one of its offices a copy of each Assignment and Acceptance delivered to it and a register for the recordation of the names and addresses of the Lenders, and the Commitments of, and principal and interest amounts of the Loans and Revolving L/C Exposure owing to, each Lender pursuant to the terms hereof from time to time (the “Register”). The entries in the Register shall be conclusive absent manifest error, and the Borrower, the Administrative Agent, the Issuing Bank, the Swingline Lender and the Lenders shall treat each person whose name is recorded in the Register pursuant to the terms hereof as a Lender hereunder for all purposes of this Agreement, notwithstanding notice to the contrary. The Register shall be available for inspection by the Borrower, the Issuing Bank, the Swingline Lender and any Lender, at any reasonable time and from time to time upon reasonable prior notice.

(v) Upon its receipt of a duly completed Assignment and Acceptance executed by an assigning Lender and an Assignee, the Assignee’s completed Administrative Questionnaire (unless the Assignee shall already be a Lender hereunder), the processing and recordation fee referred to in clause (b) of this Section, if applicable, and any written consent to such assignment required by clause (b) of this Section and any applicable tax forms, the Administrative Agent shall accept such Assignment and Acceptance and promptly record the information contained therein in the Register. No assignment, whether or not evidenced by a promissory note, shall be effective for purposes of this Agreement unless it has been recorded in the Register as provided in this subclause (v).

(c) By executing and delivering an Assignment and Acceptance, the assigning Lender thereunder and the Assignee thereunder shall be deemed to confirm to and agree with each other and the other parties hereto as follows: (i) such assigning Lender warrants that it is the legal and beneficial owner of the interest being assigned thereby free and clear of any adverse claim and that its applicable Commitment, and the outstanding balances of its Loans, in each case without giving effect to assignments thereof which have not become effective, are as set forth in such Assignment and Acceptance, (ii) except as set forth in clause (i) above, such assigning Lender makes no representation or warranty and assumes no responsibility with respect to any statements, warranties or representations made in or in connection with this Agreement, or the execution, legality, validity, enforceability, genuineness, sufficiency or value of this Agreement, any other Loan Document or any other instrument or document furnished pursuant hereto, or the financial condition of any Loan Party or any of its subsidiaries or the performance or observance by any Loan Party or any of its subsidiaries of any of such person’s obligations under this Agreement, any other Loan Document or any other instrument or document furnished pursuant hereto; (iii) the Assignee represents and warrants that it is legally authorized to enter into such Assignment and Acceptance; (iv) the Assignee confirms that it has received a copy of this Agreement, together with copies of the most recent financial statements delivered pursuant to Section 5.04, and such other documents and information as it has deemed appropriate to make its own credit analysis and decision to enter into such Assignment and Acceptance; (v) the Assignee will independently and without reliance upon the Agents, such assigning Lender or any other Lender and based on such documents and information as it shall deem appropriate at the time, continue to make its own credit decisions in taking or not taking action under this Agreement; (vi) the Assignee appoints and authorizes each Agent to take such action as agent on its behalf and to exercise such powers under this Agreement as are delegated to such Agent, by the terms of this Agreement, together with such powers as are reasonably incidental thereto; and (vii) the Assignee agrees that it will perform in accordance with their terms all the obligations which by the terms of this Agreement are required to be performed by it as a Lender.

(d) (i) Any Lender may, without the consent of the Borrower or the Administrative Agent, sell participations to one or more banks or other entities other than any Ineligible Institution (to the extent that the list of Ineligible Institutions has been made available to all Lenders) (a “Participant”) in all or a portion of such Lender’s rights and obligations under this Agreement (including all or a portion of its Commitments and the Loans owing to it); provided, that (A) such Lender’s obligations under this Agreement shall remain unchanged, (B) such Lender shall remain solely responsible to the other parties hereto for the performance of such obligations and (C) the Borrower, the Administrative Agent, the Issuing Bank and the other Lenders shall continue to deal solely and directly with such Lender in connection with such Lender’s rights and obligations under this Agreement. Any agreement pursuant to which a Lender sells such a participation shall provide that such Lender shall retain the sole right to enforce this Agreement and the other Loan Documents and to approve any amendment, modification or waiver of any provision of this Agreement and the other Loan Documents; provided, that (x) such agreement may provide that such Lender will not, without the consent of the Participant, agree to any amendment, modification or waiver that (1) requires the consent of each Lender directly affected thereby pursuant to clause (i), (ii), (iii) or (vi) of the first proviso to Section 9.08(b) and (2) directly affects such Participant (but, for the avoidance of doubt, not any waiver of any Default or Event of Default) and (y) no other agreement with respect to amendment, modification or waiver may exist between such Lender and such Participant. Subject to clause (e)(iii) of this Section 9.04, the Borrower agrees that each Participant shall be entitled to the benefits of Sections 2.15, 2.16 and 2.17 (subject to the limitations and requirements of those Sections and Section 2.19) to the same extent as if it were a Lender and had acquired its interest by assignment pursuant to clause (b) of this Section 9.04. To the extent permitted by law, each Participant also shall be entitled to the benefits of Section 9.06 as though it were a Lender; provided, that such Participant shall be subject to Section 2.18(c) as though it were a Lender. Notwithstanding the foregoing, each Loan Party and the Lenders acknowledge and agree that the Administrative Agent shall not have any responsibility or obligation to determine whether any Participant or potential Participant is an Ineligible Institution and the Administrative Agent shall have no liability with respect to any participation made to an Ineligible Institution.

(ii) Each Lender that sells a participation shall, acting solely for this purpose as a non-fiduciary agent of the Borrower, maintain a register on which it enters the name and address of each Participant and the principal amounts and interest amounts of each Participant’s interest in the Loans or other obligations under the Loan Documents (the “Participant Register”). The entries in the Participant Register shall be conclusive absent manifest error, and each party hereto shall treat each person whose name is recorded in the Participant Register as the owner of such participation for all purposes of this Agreement notwithstanding any notice to the contrary. Without limitation of the requirements of Section 9.04(d), no Lender shall have any obligation to disclose all or any portion of a Participant Register to any person (including the identity of any Participant or any information relating to a Participant’s interest in any Commitments, Loans or other Loan Obligations under any Loan Document), except to the extent that such disclosure is necessary to establish that such

Commitment, Loan or other Loan Obligation is in registered form for U.S. federal income tax purposes or is otherwise required by applicable law. For the avoidance of doubt, the Administrative Agent (in its capacity as Administrative Agent) shall have no responsibility for maintaining a Participant Register.

(iii) A Participant shall not be entitled to receive any greater payment under Section 2.15, 2.16 or 2.17 than the applicable Lender would have been entitled to receive with respect to the participation sold to such Participant, unless the sale of the participation to such Participant is made with the Borrower's prior written consent, which consent shall state that it is being given pursuant to this Section 9.04(d)(iii); provided, that each potential Participant shall provide such information as is reasonably requested by the Borrower in order for the Borrower to determine whether to provide its consent.

(e) Any Lender may at any time pledge or assign a security interest in all or any portion of its rights under this Agreement to secure obligations of such Lender, including any pledge or assignment to secure obligations to a Federal Reserve Bank and in the case of any Lender that is an Approved Fund, any pledge or assignment to any holders of obligations owed, or securities issued, by such Lender, including to any trustee for, or any other representative of, such holders, and this Section 9.04 shall not apply to any such pledge or assignment of a security interest; provided, that no such pledge or assignment of a security interest shall release a Lender from any of its obligations hereunder or substitute any such pledgee or Assignee for such Lender as a party hereto.

(f) The Borrower, upon receipt of written notice from the relevant Lender, agrees to issue Notes to any Lender requiring Notes to facilitate transactions of the type described in clause (e) above.

(g) Notwithstanding the foregoing, any Conduit Lender may assign any or all of the Loans it may have funded hereunder to its designating Lender without the consent of the Borrower or the Administrative Agent. Each of Holdings, the Borrower, each Lender and the Administrative Agent hereby confirms that it will not institute against a Conduit Lender or join any other person in instituting against a Conduit Lender any bankruptcy, reorganization, arrangement, insolvency or liquidation proceeding under any state bankruptcy or similar law, for one year and one day after the payment in full of the latest maturing commercial paper note issued by such Conduit Lender; provided, however, that each Lender designating any Conduit Lender hereby agrees to indemnify, save and hold harmless each other party hereto and each Loan Party for any loss, cost, damage or expense arising out of its inability to institute such a proceeding against such Conduit Lender during such period of forbearance.

(h) If the Borrower wishes to replace the Loans or Commitments under any Facility with ones having different terms, it shall have the option, with the consent of the Administrative Agent and subject to at least three Business Days' advance notice to the Lenders under such Facility, instead of prepaying the Loans or reducing or terminating the Commitments to be replaced, to (i) require the Lenders under such Facility to assign such Loans or Commitments to the Administrative Agent or its designees and (ii) amend the terms thereof in accordance with Section 9.08. Pursuant to any such assignment, all Loans and Commitments to be replaced shall be purchased at par (allocated among the Lenders under such Facility in the

same manner as would be required if such Loans were being optionally prepaid or such Commitments were being optionally reduced or terminated by the Borrower), accompanied by payment of any accrued interest and fees thereon and any amounts owing pursuant to Section 9.05(b). By receiving such purchase price, the Lenders under such Facility shall automatically be deemed to have assigned the Loans or Commitments under such Facility pursuant to the terms of the form of Assignment and Acceptance attached hereto as Exhibit A, and accordingly no other action by such Lenders shall be required in connection therewith. The provisions of this clause (h) are intended to facilitate the maintenance of the perfection and priority of existing security interests in the Collateral during any such replacement.

(i) In connection with any assignment of rights and obligations of any Defaulting Lender hereunder, no such assignment shall be effective unless and until, in addition to the other conditions thereto set forth herein, the parties to the assignment shall make such additional payments to the Administrative Agent in an aggregate amount sufficient, upon distribution thereof as appropriate (which may be outright payment, purchases by the assignee of participations or subparticipations, or other compensating actions, including funding, with the consent of the Borrower and the Administrative Agent, the applicable pro rata share of Loans previously requested but not funded by the Defaulting Lender, to each of which the applicable assignee and assignor hereby irrevocably consent), to (x) pay and satisfy in full all payment liabilities then owed by such Defaulting Lender to the Administrative Agent, any Lender or any Issuing Bank hereunder (and interest accrued thereon) and (y) acquire (and fund as appropriate) its full pro rata share of all Loans; provided, that notwithstanding the foregoing, in the event that any assignment of rights and obligations of any Defaulting Lender hereunder shall become effective under applicable law without compliance with the provisions of this paragraph, then the assignee of such interest shall be deemed to be a Defaulting Lender for all purposes of this Agreement until such compliance occurs.

Section 9.05 Expenses; Indemnity. (a) The Borrower agrees to pay (i) all reasonable and documented out-of-pocket expenses (including Other Taxes) incurred by the Administrative Agent or the Collateral Agent in connection with the preparation of this Agreement and the other Loan Documents, or by the Administrative Agent or the Collateral Agent in connection with the administration of this Agreement and any amendments, modifications or waivers of the provisions hereof or thereof, including the reasonable fees, charges and disbursements of Cahill Gordon & Reindel LLP, counsel to the Administrative Agent, the Collateral Agent and the Arranger, and, if necessary, the reasonable fees, charges and disbursements of one local counsel per jurisdiction, and (ii) all out-of-pocket expenses (including Other Taxes) incurred by the Agents or any Lender in connection with the enforcement of their rights in connection with this Agreement and the other Loan Documents, in connection with the Loans made or the Letters of Credit issued hereunder, including the fees, charges and disbursements of a single counsel for all such persons, taken as a whole, and, if necessary, a single local counsel in each appropriate jurisdiction for all such persons, taken as a whole (and, in the case of an actual or perceived conflict of interest where such person affected by such conflict informs the Borrower of such conflict and thereafter retains its own counsel with the Borrower's prior written consent (not to be unreasonably withheld), of another firm of such for such affected person).



(b) The Borrower agrees to indemnify the Administrative Agent, the Collateral Agent, the Arranger, the Bookrunner, each Issuing Bank, each Lender, each of their respective Affiliates and each of their respective directors, officers, employees, agents and advisors (each such person being called an “Indemnitee”) against, and to hold each Indemnitee harmless from, any and all losses, claims, damages, liabilities and related expenses, including reasonable counsel fees, charges and disbursements (excluding the allocated costs of in house counsel and limited to not more than one counsel for all such Indemnitees, taken as a whole, and, if necessary, a single local counsel in each appropriate jurisdiction for all such Indemnitees, taken as a whole (and, in the case of an actual or perceived conflict of interest where the Indemnitee affected by such conflict informs the Borrower of such conflict and thereafter retains its own counsel with the Borrower’s prior written consent (not to be unreasonably withheld), of another firm of counsel for such affected Indemnitee)), incurred by or asserted against any Indemnitee arising out of, in any way connected with, or as a result of (i) the execution or delivery of this Agreement or any other Loan Document or any agreement or instrument contemplated hereby or thereby, the performance by the parties hereto and thereto of their respective obligations thereunder or the consummation of the Transactions and the other transactions contemplated hereby, (ii) the use of the proceeds of the Loans or the use of any Letter of Credit, (iii) any violation of or liability under Environmental Laws by the Borrower or any Subsidiary, (iv) any actual or alleged presence, Release or threatened Release of or exposure to Hazardous Materials at, under, on, from or to any property owned, leased or operated by the Borrower or any Subsidiary or (v) any claim, litigation, investigation or proceeding relating to any of the foregoing, whether or not any Indemnitee is a party thereto and regardless of whether such matter is initiated by a third party or by Holdings, the Borrower or any of their subsidiaries or Affiliates; provided, that such indemnity shall not, as to any Indemnitee, be available to the extent that such losses, claims, damages, liabilities or related expenses (x) are determined by a final, non-appealable judgment of a court of competent jurisdiction to have resulted from the gross negligence, bad faith or willful misconduct of such Indemnitee or any of its Related Parties, (y) arose from a material breach of such Indemnitee’s or any of its Related Parties’ obligations under any Loan Document (as determined by a court of competent jurisdiction in a final, non-appealable judgment) or (z) arose from any claim, actions, suits, inquiries, litigation, investigation or proceeding that does not involve an act or omission of the Borrower or any of its Affiliates and is brought by an Indemnitee against another Indemnitee (other than any claim, actions, suits, inquiries, litigation, investigation or proceeding against any Agent or an Arranger, in its capacity as such). None of the Indemnitees (or any of their respective affiliates) shall be responsible or liable to the Fund, Holdings, the Borrower or any of their respective subsidiaries, Affiliates or stockholders or any other person or entity for any special, indirect, consequential or punitive damages, which may be alleged as a result of the Facilities or the Transactions. The provisions of this Section 9.05 shall remain operative and in full force and effect regardless of the expiration of the term of this Agreement, the consummation of the transactions contemplated hereby, the repayment of any of the Obligations, the invalidity or unenforceability of any term or provision of this Agreement or any other Loan Document, or any investigation made by or on behalf of the Administrative Agent, any Issuing Bank or any Lender. All amounts due under this Section 9.05 shall be payable within 15 days after written demand therefor accompanied by reasonable documentation with respect to any reimbursement, indemnification or other amount requested.

(c) Except as expressly provided in Section 9.05(a) with respect to Other Taxes, which shall not be duplicative with any amounts paid pursuant to Section 2.17, this Section 9.05 shall not apply to any Taxes (other than Taxes that represent losses, claims, damages, liabilities and related expenses resulting from a non-Tax claim), which shall be governed exclusively by Section 2.17 and, to the extent set forth therein, Section 2.15.

(d) To the fullest extent permitted by applicable law, Holdings and the Borrower shall not assert, and hereby waive, any claim against any Indemnitee, on any theory of liability, for special, indirect, consequential or punitive damages (as opposed to direct or actual damages) arising out of, in connection with, or as a result of, this Agreement, any other Loan Document or any agreement or instrument contemplated hereby, the transactions contemplated hereby or thereby, any Loan or Letter of Credit or the use of the proceeds thereof. No Indemnitee shall be liable for any damages arising from the use by unintended recipients of any information or other materials distributed by it through telecommunications, electronic or other information transmission systems in connection with this Agreement or the other Loan Documents or the transactions contemplated hereby or thereby.

(e) The agreements in this Section 9.05 shall survive the resignation of the Administrative Agent, the Collateral Agent or any Issuing Bank, the replacement of any Lender, the termination of the Commitments and the repayment, satisfaction or discharge of all the other Obligations and the termination of this Agreement.

Section 9.06 Right of Set-off. If an Event of Default shall have occurred and be continuing, each Lender and each Issuing Bank is hereby authorized at any time and from time to time, to the fullest extent permitted by law, to set off and apply any and all deposits (general or special, time or demand, provisional or final) at any time held and other indebtedness at any time owing by such Lender or such Issuing Bank to or for the credit or the account of Holdings (prior to a Qualified IPO), the Borrower or any Subsidiary against any of and all the obligations of Holdings (prior to a Qualified IPO) or the Borrower now or hereafter existing under this Agreement or any other Loan Document held by such Lender or such Issuing Bank, irrespective of whether or not such Lender or such Issuing Bank shall have made any demand under this Agreement or such other Loan Document and although the obligations may be unmatured; provided, that in the event that any Defaulting Lender shall exercise any such right of setoff, (x) all amounts so set off shall be paid over immediately to the Administrative Agent for further application in accordance with the provisions of Section 2.22 and, pending such payment, shall be segregated by such Defaulting Lender from its other funds and deemed held in trust for the benefit of the Administrative Agent and the Lenders, and (y) the Defaulting Lender shall provide promptly to the Administrative Agent a statement describing in reasonable detail the Obligations owing to such Defaulting Lender as to which it exercised such right of setoff. The rights of each Lender and each Issuing Bank under this Section 9.06 are in addition to other rights and remedies (including other rights of set-off) that such Lender or such Issuing Bank may have.

Section 9.07 Applicable Law. THIS AGREEMENT AND THE OTHER LOAN DOCUMENTS AND ANY CLAIMS, CONTROVERSY, DISPUTE OR CAUSES OF ACTION (WHETHER IN CONTRACT OR TORT OR OTHERWISE) BASED UPON, ARISING OUT OF OR RELATING TO THIS AGREEMENT OR ANY OTHER LOAN DOCUMENT (OTHER THAN AS EXPRESSLY SET FORTH IN OTHER LOAN DOCUMENTS) SHALL BE CONSTRUED IN ACCORDANCE WITH AND GOVERNED BY THE LAWS OF THE STATE OF NEW YORK, WITHOUT REGARD TO ANY PRINCIPLE OF CONFLICTS OF LAW THAT COULD REQUIRE THE APPLICATION OF ANY OTHER LAW.

Section 9.08 Waivers; Amendment. (a) No failure or delay of the Agents, any Issuing Bank or any Lender in exercising any right or power hereunder or under any Loan Document shall operate as a waiver thereof, nor shall any single or partial exercise of any such right or power, or any abandonment or discontinuance of steps to enforce such a right or power, preclude any other or further exercise thereof or the exercise of any other right or power. The rights and remedies of the Agents, each Issuing Bank and the Lenders hereunder and under the other Loan Documents are cumulative and are not exclusive of any rights or remedies that they would otherwise have. No waiver of any provision of this Agreement or any other Loan Document or consent to any departure by Holdings, the Borrower or any other Loan Party therefrom shall in any event be effective unless the same shall be permitted by clause (b) below, and then such waiver or consent shall be effective only in the specific instance and for the purpose for which given. No notice or demand on Holdings, the Borrower or any other Loan Party in any case shall entitle such person to any other or further notice or demand in similar or other circumstances.

(b) Neither this Agreement nor any other Loan Document nor any provision hereof or thereof may be waived, amended or modified except (x) as provided in Section 2.21, (y) in the case of this Agreement, pursuant to an agreement or agreements in writing entered into by Holdings (prior to a Qualified IPO), the Borrower and the Required Lenders, and (z) in the case of any other Loan Document, pursuant to an agreement or agreements in writing entered into by each Loan Party party thereto and the Agents and consented to by the Required Lenders; provided, however, that no such agreement shall:

(i) decrease or forgive the principal amount of, or extend the final maturity of, or decrease the rate of interest on, any Loan or any L/C Disbursement, or extend the stated expiration of any Letter of Credit beyond the applicable Maturity Date (except as provided in Section 2.05(c)), without the prior written consent of each Lender directly adversely affected thereby (which, notwithstanding the foregoing, such consent of such Lender directly adversely affected thereby shall be the only consent required hereunder to make such modification); provided, that any amendment to the definitions of “Borrowing Base”, “Availability” and the related definitions and the financial definitions in this Agreement shall not constitute a reduction in the rate of interest for purposes of this clause (i),

(ii) increase or extend the Commitment of any Lender, or decrease the Commitment Fees or L/C Participation Fees of any Lender, without the prior written consent of such Lender (which, notwithstanding the foregoing, such consent of such Lender shall be the only consent required hereunder to make such modification); provided, that waivers or modifications of conditions precedent, covenants, Defaults or Events of Default or of a mandatory reduction in the aggregate Commitments shall not constitute an increase of the Commitments of any Lender,

(iii) extend any date on which payment of interest on any Loan or any L/C Disbursement or any Fees is due, without the prior written consent of each Lender directly adversely affected thereby (which, notwithstanding the foregoing, such consent of such Lender directly adversely affected thereby shall be the only consent required hereunder to make such modification),

(iv) amend the provisions of Section 7.03 (including clauses first through ninth of Section 2.18(b) as used in Section 7.03) in a manner that would by its terms alter the pro rata sharing of payments required thereby, without the prior written consent of each Lender adversely affected thereby (which, notwithstanding the foregoing, such consent of such Lender directly adversely affected thereby shall be the only consent required hereunder to make such modification),

(v) amend or modify the provisions of this Section 9.08 or the definition of the terms “Required Lenders”, “Super Majority Lenders” or any other provision hereof specifying the number or percentage of Lenders required to waive, amend or modify any rights hereunder or make any determination or grant any consent hereunder, without the prior written consent of each Lender adversely affected thereby (it being understood that, with the consent of the Required Lenders, additional extensions of credit pursuant to this Agreement may be included in the determination of the Required Lenders and the Super Majority Lenders on substantially the same basis as the Loans and Commitments are included on the Closing Date), except as provided in Section 9.08(e),

(vi) release all or substantially all of the Collateral, or all or substantially all of the Subsidiary Loan Parties from their respective Guarantees under the Guarantee Agreement, unless, in the case of a Subsidiary Loan Party, all or substantially all the Equity Interests of such Subsidiary Loan Party is sold or otherwise disposed of in a transaction permitted by this Agreement, without the prior written consent of each Lender, or

(vii) change the definition of the term “Borrowing Base” or any component definition thereof if as a result thereof the amounts available to be borrowed by the Borrower would be increased (provided, that the foregoing shall not limit the discretion of the Administrative Agent to change, establish or eliminate any Reserves without the prior written consent of any Lenders), in each case without the prior written consent of the Super Majority Lenders;

provided, further, that no such agreement shall amend, modify or otherwise affect the rights or duties of the Administrative Agent, the Collateral Agent or an Issuing Bank hereunder without the prior written consent of the Administrative Agent, the Collateral Agent or such Issuing Bank acting as such at the effective date of such agreement, as applicable. Each Lender shall be bound by any waiver, amendment or modification authorized by this Section 9.08 and any consent by any Lender pursuant to this Section 9.08 shall bind any Assignee of such Lender.

Notwithstanding anything to the contrary herein, no Defaulting Lender shall have the right to approve or disapprove any amendment, waiver or consent hereunder (and any amendment, waiver or consent which by its terms requires the consent of all Lenders or each affected Lender may be affected with the consent of the applicable Lenders other than Defaulting Lenders),

except that (x) the Commitment of any Defaulting Lender may not be increased or extended without the consent of such Lender and (y) any waiver, amendment or modification requiring the consent of all Lenders or each affected Lender that by its terms affects any Defaulting Lender disproportionately adversely relative to other affected Lenders shall require the consent of such Defaulting Lender.

(c) Without the consent of any Lender or any Issuing Bank, the Loan Parties and the Administrative Agent may (in their respective sole discretion, or shall, to the extent required by any Loan Document) enter into any amendment, modification or waiver of any Loan Document, or enter into any new agreement or instrument, to effect the granting, perfection, protection, expansion or enhancement of any security interest in any Collateral or additional property to become Collateral for the benefit of the Secured Parties, or as required by local law to give effect to, or protect any security interest for the benefit of the Secured Parties, in any property or so that the security interests therein comply with applicable law or this Agreement or in each case to otherwise enhance the rights or benefits of any Lender under any Loan Document.

(d) [Reserved].

(e) Notwithstanding the foregoing, technical and conforming modifications to the Loan Documents may be made with the consent of the Borrower and the Agents (but without the consent of any Lender) to the extent necessary (A) to cure any ambiguity, omission, defect or inconsistency or (B) to integrate any Incremental Revolving Commitments in a manner consistent with Section 2.21, including, with respect to Extended Revolving Loans, as may be necessary to establish such Extended Revolving Loans as a separate Class or tranche from the existing Loans or Commitments. The Administrative Agent and the Borrower shall modify the Loan Documents to include the commitments to make such Extended Revolving Loans (and any letter of credit and swingline exposure thereunder) in the definition of Required Lenders and Super Majority Lenders on substantially the same basis as the Loans are included on the Closing Date.

(f) With respect to the incurrence of any secured or unsecured Indebtedness (including any intercreditor agreement relating thereto), the Borrower may elect (in its discretion, but shall not be obligated) to deliver to the Administrative Agent a certificate of a Responsible Officer at least three Business Days prior to the incurrence thereof (or such shorter time as the Administrative Agent may agree), together with either drafts of the material documentation relating to such Indebtedness or a description of such Indebtedness (including a description of the Liens intended to secure the same or the subordination provisions thereof, as applicable) in reasonably sufficient detail to be able to make the determinations referred to in this paragraph, which certificate shall either, at the Borrower's election, (x) state that the Borrower has determined in good faith that such Indebtedness satisfies the requirements of the applicable provisions of Sections 6.01 and 6.02 (taking into account any other applicable provisions of this Section 9.08), in which case such certificate shall be conclusive evidence thereof, or (y) request the Administrative Agent to confirm, based on the information set forth in such certificate and any other information reasonably requested by the Administrative Agent, that such Indebtedness satisfies such requirements, in which case the Administrative Agent may determine whether, in

its reasonable judgment, such requirements have been satisfied (in which case it shall deliver to the Borrower a written confirmation of the same), with any such determination of the Administrative Agent to be conclusive evidence thereof, and the Lenders hereby authorize the Administrative Agent to make such determinations.

Section 9.09 Interest Rate Limitation. Notwithstanding anything herein to the contrary, if at any time the applicable interest rate, together with all fees and charges that are treated as interest under applicable law (collectively, the "Charges"), as provided for herein or in any other document executed in connection herewith, or otherwise contracted for, charged, received, taken or reserved by any Lender or any Issuing Bank, shall exceed the maximum lawful rate (the "Maximum Rate") that may be contracted for, charged, taken, received or reserved by such Lender in accordance with applicable law, the rate of interest payable hereunder, together with all Charges payable to such Lender or such Issuing Bank, shall be limited to the Maximum Rate; provided, that such excess amount shall be paid to such Lender or such Issuing Bank on subsequent payment dates to the extent not exceeding the legal limitation.

Section 9.10 Entire Agreement. This Agreement, the other Loan Documents and the agreements regarding certain Fees referred to herein constitute the entire contract between the parties relative to the subject matter hereof. Any previous agreement among or representations from the parties or their Affiliates with respect to the subject matter hereof is superseded by this Agreement and the other Loan Documents. Notwithstanding the foregoing, the Fee Letter shall survive the execution and delivery of this Agreement and remain in full force and effect. Nothing in this Agreement or in the other Loan Documents, expressed or implied, is intended to confer upon any party other than the parties hereto and thereto any rights, remedies, obligations or liabilities under or by reason of this Agreement or the other Loan Documents.

Section 9.11 WAIVER OF JURY TRIAL. EACH PARTY HERETO HEREBY WAIVES, TO THE FULLEST EXTENT PERMITTED BY APPLICABLE LAW, ANY RIGHT IT MAY HAVE TO A TRIAL BY JURY IN RESPECT OF ANY LITIGATION DIRECTLY OR INDIRECTLY ARISING OUT OF, UNDER OR IN CONNECTION WITH THIS AGREEMENT OR ANY OF THE OTHER LOAN DOCUMENTS (WHETHER BASED ON CONTRACT, TORT OR ANY OTHER THEORY). EACH PARTY HERETO (A) CERTIFIES THAT NO REPRESENTATIVE, AGENT OR ATTORNEY OF ANY OTHER PARTY HAS REPRESENTED, EXPRESSLY OR OTHERWISE, THAT SUCH OTHER PARTY WOULD NOT, IN THE EVENT OF LITIGATION, SEEK TO ENFORCE THE FOREGOING WAIVER AND (B) ACKNOWLEDGES THAT IT AND THE OTHER PARTIES HERETO HAVE BEEN INDUCED TO ENTER INTO THIS AGREEMENT AND THE OTHER LOAN DOCUMENTS, AS APPLICABLE, BY, AMONG OTHER THINGS, THE MUTUAL WAIVERS AND CERTIFICATIONS IN THIS SECTION 9.11.

Section 9.12 Severability. In the event any one or more of the provisions contained in this Agreement or in any other Loan Document should be held invalid, illegal or unenforceable in any respect, the validity, legality and enforceability of the remaining provisions contained herein and therein shall not in any way be affected or impaired thereby. The parties shall endeavor in good-faith negotiations to replace the invalid, illegal or unenforceable provisions with valid provisions the economic effect of which comes as close as possible to that of the invalid, illegal or unenforceable provisions.

Section 9.13 Counterparts. This Agreement may be executed in two or more counterparts, each of which shall constitute an original but all of which, when taken together, shall constitute but one contract, and shall become effective as provided in Section 9.03. Delivery of an executed counterpart to this Agreement by facsimile transmission (or other electronic transmission pursuant to procedures approved by the Administrative Agent) shall be as effective as delivery of a manually signed original.

Section 9.14 Headings. Article and Section headings and the Table of Contents used herein are for convenience of reference only, are not part of this Agreement and are not to affect the construction of, or to be taken into consideration in interpreting, this Agreement.

Section 9.15 Jurisdiction; Consent to Service of Process. (a) The Borrower and each other Loan Party irrevocably and unconditionally agrees that it will not commence any action, litigation or proceeding of any kind or description, whether in law or equity, whether in contract or in tort or otherwise, against the Administrative Agent, the Collateral Agent, any Lender, or any Affiliate of the foregoing in any way relating to this Agreement or any other Loan Document or the transactions relating hereto or thereto, in any forum other than the courts of the State of New York sitting in New York County, and of the United States District Court of the Southern District of New York, and any appellate court from any thereof, and each of the parties hereto irrevocably and unconditionally submits to the jurisdiction of such courts and agrees that all claims in respect of any such action, litigation or proceeding may be heard and determined in such New York State court or, to the fullest extent permitted by applicable law, in such federal court. Each of the parties hereto agrees that a final judgment in any such action, litigation or proceeding shall be conclusive and may be enforced in other jurisdictions by suit on the judgment or in any other manner provided by law. Nothing in this Agreement or in any other Loan Document shall affect any right that the Administrative Agent or any Lender may otherwise have to bring any action or proceeding relating to this Agreement or any other Loan Document against the Borrower or any other Loan Party or its properties in the courts of any jurisdiction.

(b) Each of the parties hereto hereby irrevocably and unconditionally waives, to the fullest extent it may legally and effectively do so, any objection which it may now or hereafter have to the laying of venue of any suit, action or proceeding arising out of or relating to this Agreement or the other Loan Documents in any New York State or federal court. Each of the parties hereto hereby irrevocably waives, to the fullest extent permitted by law, the defense of an inconvenient forum to the maintenance of such action or proceeding in any such court.

(c) Each party to this Agreement irrevocably consents to service of process in the manner provided for notices in Section 9.01. Nothing in this Agreement will affect the right of any party to this Agreement or any other Loan Document to serve process in any other manner permitted by law.

Section 9.16 Confidentiality. Each of the Lenders, each Issuing Bank and each of the Agents agrees that it shall maintain in confidence any information relating to Holdings, any Parent Entity, the Borrower and any Subsidiary furnished to it by or on behalf of Holdings, any Parent Entity, the Borrower or any Subsidiary (other than information that (a) has become generally available to the public other than as a result of a disclosure by such party, (b) has been independently developed by such Lender, such Issuing Bank or such Agent without violating this Section 9.16 or (c) was available to such Lender, such Issuing Bank or such Agent from a third party having, to such person's knowledge, no obligations of confidentiality to Holdings, any Parent Entity, the Borrower or any other Loan Party) and shall not reveal the same other than to its directors, trustees, officers, employees and advisors with a need to know and any numbering, administration or settlement service providers or to any person that approves or administers the Loans on behalf of such Lender (so long as each such person shall have been instructed to keep the same confidential in accordance with this Section 9.16), except: (A) to the extent necessary to comply with law or any legal process or the requirements of any Governmental Authority, the National Association of Insurance Commissioners or of any securities exchange on which securities of the disclosing party or any Affiliate of the disclosing party are listed or traded, (B) as part of normal reporting or review procedures to, or examinations by, Governmental Authorities or self-regulatory authorities, including the National Association of Insurance Commissioners or the National Association of Securities Dealers, Inc., (C) to its parent companies, Affiliates or auditors (so long as each such person shall have been instructed to keep the same confidential in accordance with this Section 9.16), (D) in order to enforce its rights under any Loan Document in a legal proceeding, (E) to any pledgee under Section 9.04(d) or any other prospective assignee of, or prospective Participant in, any of its rights under this Agreement (so long as such person shall have been instructed to keep the same confidential in accordance with this Section 9.16) and (F) to any direct or indirect contractual counterparty in Hedging Agreements or such contractual counterparty's professional advisor (so long as such contractual counterparty or professional advisor to such contractual counterparty agrees to be bound by the provisions of this Section 9.16).

Section 9.17 Platform; Borrower Materials. The Borrower hereby acknowledges that (a) the Administrative Agent and/or the Arranger will make available to the Lenders and the Issuing Bank materials and/or information provided by or on behalf of the Borrower hereunder (collectively, "Borrower Materials") by posting the Borrower Materials on IntraLinks or another similar electronic system (the "Platform"), and (b) certain of the Lenders may be "public-side" Lenders (i.e., Lenders that do not wish to receive material non-public information (or, in the case of a company that is not a public-reporting company, material information of a type that would not be reasonably expected to be publicly available if such company were a public-reporting company) with respect to Holdings, the Borrower or its Subsidiaries or any of their respective securities) (each, a "Public Lender"). The Borrower hereby agrees that it will use commercially reasonable efforts to identify that portion of the Borrower Materials that may be distributed to the Public Lenders and that (i) all such Borrower Materials shall be clearly and conspicuously marked "PUBLIC" which, at a minimum, shall mean that the word "PUBLIC" shall appear prominently on the first page thereof, (ii) by marking Borrower Materials "PUBLIC," the Borrower shall be deemed to have authorized the Administrative Agent, the Arranger, the Issuing Bank and the Lenders to treat such Borrower Materials as solely containing information that is either (A) of a type that would reasonably be expected to be publicly available information if Holdings or the Borrower were a public reporting company or (B) not material (although it may be sensitive and proprietary) with respect



to Holdings, the Borrower or its Subsidiaries or any of their respective securities for purposes of United States Federal and state securities laws (provided, however, that such Borrower Materials shall be treated as set forth in Section 9.16, to the extent such Borrower Materials constitute information subject to the terms thereof), (iii) all Borrower Materials marked "PUBLIC" are permitted to be made available through a portion of the Platform designated "Public Investor;" and (iv) the Administrative Agent and the Arranger shall be entitled to treat any Borrower Materials that are not marked "PUBLIC" as being suitable only for posting on a portion of the Platform not designated "Public Investor."

Section 9.18 Release of Liens and Guarantees. (a) The Lenders and the Issuing Banks hereby irrevocably agree that the Liens granted to the Collateral Agent by the Loan Parties on any Collateral shall be automatically released: (i) in full upon the occurrence of the Termination Date as set forth in Section 9.18(d) below; (ii) upon the Disposition of such Collateral by any Loan Party to a person that is not (and is not required to become) a Loan Party in a transaction not prohibited by this Agreement (and the Collateral Agent may rely conclusively on a certificate to that effect provided to it by any Loan Party upon its reasonable request without further inquiry), (iii) to the extent that such Collateral comprises property leased to a Loan Party, upon termination or expiration of such lease (and the Collateral Agent may rely conclusively on a certificate to that effect provided to it by any Loan Party upon its reasonable request without further inquiry), (iv) if the release of such Lien is approved, authorized or ratified in writing by the Required Lenders (or such other percentage of the Lenders whose consent may be required in accordance with Section 9.08), (v) to the extent that the property constituting such Collateral is owned by any Guarantor, upon the release of such Guarantor from its obligations under the Guarantee in accordance with the Guarantee Agreement or clause (b) below (and the Collateral Agent may rely conclusively on a certificate to that effect provided to it by any Loan Party upon its reasonable request without further inquiry), (vi) as provided in Section 8.11 (and the Collateral Agent may rely conclusively on a certificate to that effect provided to it by any Loan Party upon its reasonable request without further inquiry) and (vii) as required by the Collateral Agent to effect any Disposition of Collateral in connection with any exercise of remedies of the Collateral Agent pursuant to the Security Documents. Any such release shall not in any manner discharge, affect, or impair the Obligations or any Liens (other than those being released) upon (or obligations (other than those being released) of the Loan Parties in respect of) all interests retained by the Loan Parties, including the proceeds of any Disposition, all of which shall continue to constitute part of the Collateral except to the extent otherwise released in accordance with the provisions of the Loan Documents.

(b) In addition, (i) the Lenders hereby irrevocably agree that the Guarantors shall be released from the Guarantees upon consummation of any transaction not prohibited hereunder resulting in such Subsidiary ceasing to constitute a Subsidiary Loan Party or otherwise becoming an Excluded Subsidiary (and the Collateral Agent may rely conclusively on a certificate to that effect provided to it by any Loan Party upon its reasonable request without further inquiry) and (ii) immediately prior to the consummation of a Qualified IPO of the Borrower, the Guarantee incurred by Holdings of the Obligations shall automatically terminate and Holdings shall be released from its obligations under the Loan Documents, shall cease to be a Loan Party and any Liens created by any Loan Documents on any Equity Interests or other assets owned by Holdings shall automatically be released (unless the Borrower shall elect in its sole discretion that such release of Holdings shall not be effected).

(c) The Lenders and the Issuing Banks hereby authorize the Administrative Agent and the Collateral Agent, as applicable, to execute and deliver any instruments, documents, and agreements necessary or desirable to evidence and confirm the release of any Guarantor or Collateral pursuant to the foregoing provisions of this Section 9.18, all without the further consent or joinder of any Lender or Issuing Bank. Any representation, warranty or covenant contained in any Loan Document relating to any such Collateral or Guarantor shall no longer be deemed to be made. In connection with any release hereunder, the Administrative Agent and the Collateral Agent shall promptly (and the Lenders and the Issuing Banks hereby authorize the Administrative Agent and the Collateral Agent to) take such action and execute any such documents as may be reasonably requested by the Borrower and at the Borrower's expense in connection with the release of any Liens created by any Loan Document in respect of such Subsidiary, property or asset; provided, that the Administrative Agent shall have received a certificate of a Responsible Officer of the Borrower containing such certifications as the Administrative Agent shall reasonably request.

(d) Notwithstanding anything to the contrary contained herein or any other Loan Document, on the Termination Date, upon request of the Borrower, the Administrative Agent and/or the Collateral Agent, as applicable, shall (without notice to, or vote or consent of, any Secured Party) take such actions as shall be required to release its security interest in all Collateral, and to release all obligations under any Loan Document, whether or not on the date of such release there may be any (i) obligations in respect of any Secured Hedge Agreements or any Secured Cash Management Agreements and (ii) any contingent indemnification obligations or expense reimburse claims not then due; provided, that the Administrative Agent shall have received a certificate of a Responsible Officer of the Borrower containing such certifications as the Administrative Agent shall reasonably request. Any such release of obligations shall be deemed subject to the provision that such obligations shall be reinstated if after such release any portion of any payment in respect of the obligations guaranteed thereby shall be rescinded or must otherwise be restored or returned upon the insolvency, bankruptcy, dissolution, liquidation or reorganization of the Borrower or any Guarantor, or upon or as a result of the appointment of a receiver, intervenor or conservator of, or trustee or similar officer for, the Borrower or any Guarantor or any substantial part of its property, or otherwise, all as though such payment had not been made. The Borrower agrees to pay all reasonable and documented out-of-pocket expenses incurred by the Administrative Agent or the Collateral Agent (and their respective representatives) in connection with taking such actions to release security interest in all Collateral and all obligations under the Loan Documents as contemplated by this Section 9.18(d).

(e) Obligations of the Borrower or any of the Subsidiaries under any Secured Cash Management Agreement or Secured Hedge Agreement (after giving effect to all netting arrangements relating to such Secured Hedge Agreements) shall be secured and guaranteed pursuant to the Security Documents only to the extent that, and for so long as, the other Obligations are so secured and guaranteed. No person shall have any voting rights under any Loan Document solely as a result of the existence of obligations owed to it under any such

Secured Hedge Agreement or Secured Cash Management Agreement. For the avoidance of doubt, no release of Collateral or Guarantors effected in the manner permitted by this Agreement shall require the consent of any holder of obligations under Secured Hedge Agreements or any Secured Cash Management Agreements.

Section 9.19 Judgment Currency. If, for the purposes of obtaining judgment in any court, it is necessary to convert a sum due hereunder or any other Loan Document in one currency into another currency, the rate of exchange used shall be that at which in accordance with normal banking procedures the Administrative Agent could purchase the first currency with such other currency on the Business Day preceding that on which final judgment is given. The obligation of the Borrower in respect of any such sum due from it to the Administrative Agent or the Lenders hereunder or under the other Loan Documents shall, notwithstanding any judgment in a currency (the "Judgment Currency") other than that in which such sum is denominated in accordance with the applicable provisions of this Agreement (the "Agreement Currency"), be discharged only to the extent that on the Business Day following receipt by the Administrative Agent of any sum adjudged to be so due in the Judgment Currency, the Administrative Agent may in accordance with normal banking procedures purchase the Agreement Currency with the Judgment Currency. If the amount of the Agreement Currency so purchased is less than the sum originally due to the Administrative Agent from the Borrower in the Agreement Currency, the Borrower agrees, as a separate obligation and notwithstanding any such judgment, to indemnify the Administrative Agent or the person to whom such obligation was owing against such loss. If the amount of the Agreement Currency so purchased is greater than the sum originally due to the Administrative Agent in such currency, the Administrative Agent agrees to return the amount of any excess to the Borrower (or to any other person who may be entitled thereto under applicable law).

Section 9.20 USA PATRIOT Act Notice. Each Lender that is subject to the USA PATRIOT Act and the Administrative Agent (for itself and not on behalf of any Lender) hereby notifies the Borrower that pursuant to the requirements of the USA PATRIOT Act, it is required to obtain, verify and record information that identifies each Loan Party, which information includes the name and address of each Loan Party and other information that will allow such Lender or the Administrative Agent, as applicable, to identify each Loan Party in accordance with the USA PATRIOT Act.

Section 9.21 Agency of the Borrower for the Loan Parties. Each of the other Loan Parties hereby appoints the Borrower as its agent for all purposes relevant to this Agreement and the other Loan Documents, including the giving and receipt of notices and the execution and delivery of all documents, instruments and certificates contemplated herein and therein and all modifications hereto and thereto.

Section 9.22 Acknowledgement and Consent to Bail-In of EEA Financial Institutions. Notwithstanding anything to the contrary in any Loan Document or in any other agreement, arrangement or understanding among any such parties, each party hereto acknowledges that any liability of any EEA Financial Institution arising under any Loan Document, to the extent such liability is unsecured, may be subject to the write-down and conversion powers of an EEA Resolution Authority and agrees and consents to, and acknowledges and agrees to be bound by:

(a) the application of any Write-Down and Conversion Powers by an EEA Resolution Authority to any such liabilities arising hereunder which may be payable to it by any party hereto that is an EEA Financial Institution; and

(b) the effects of any Bail-in Action on any such liability, including, if applicable:

(i) a reduction in full or in part or cancellation of any such liability;

(ii) a conversion of all, or a portion of, such liability into shares or other instruments of ownership in such EEA Financial Institution, its parent undertaking, or a bridge institution that may be issued to it or otherwise conferred on it, and that such shares or other instruments of ownership will be accepted by it in lieu of any rights with respect to any such liability under this Agreement or any other Loan Document; or

(iii) the variation of the terms of such liability in connection with the exercise of the write-down and conversion powers of any EEA Resolution Authority.

[Signature Pages Follow]

IN WITNESS WHEREOF, the parties hereto have caused this Agreement to be duly executed by their respective authorized officers as of the day and year first written above.

SCA ACQUISITION, LLC

By: /s/ Laurie D. Medley

Name: Laurie D. Medley

Title: Vice President,  
Assistant Secretary

*[Signature Page to Asset-Based Revolving Credit Agreement]*

BARCLAYS BANK PLC, as Administrative Agent and as a Lendor

By: /s/ Craig Malloy

Name: Craig Malloy

Title: Director

*[Signature Page to Asset-Based Revolving Credit Agreement]*

**AMENDMENT No. 1**, dated as of January 7, 2019 (this "Amendment"), to the Asset-Based Revolving Credit Agreement, dated as of December 13, 2017 (as amended, restated, supplemented or otherwise modified, refinanced or replaced from time to time, the "Credit Agreement"), among SCA ACQUISITION, LLC, a Delaware limited liability company ("Holdings"), MN AIRLINES, LLC, a Minnesota limited liability company (d/b/a Sun Country Airlines) (the "Borrower"), the Lenders from time to time party thereto and BARCLAYS BANK PLC, as Administrative Agent (together with its successors and assigns, the "Administrative Agent"). Capitalized terms used but not defined herein have the meaning provided in the Credit Agreement as amended hereby (the "Amended Credit Agreement").

WHEREAS, pursuant to Section 9.08(b) of the Credit Agreement, Holdings (prior to a Qualified IPO), the Borrower and the Required Lenders may agree to amend the Credit Agreement as set forth herein; and

WHEREAS, the parties hereto desire to amend the Credit Agreement on the terms set forth herein;

NOW, THEREFORE, in consideration of the premises and covenants contained herein and for other good and valuable consideration, the receipt and sufficiency of which are hereby acknowledged, the parties hereto, intending to be legally bound hereby, agree as follows:

Section 1. **Amendment.** Section 6.01(i) of the Credit Agreement is hereby amended and restated in its entirety as of the Amendment No. 1 Effective Date (as defined below) as follows:

“(i) (i) Capitalized Lease Obligations and mortgage financings incurred by the Borrower or any Subsidiary prior to or within 270 days after the acquisition, lease, construction, repair, replacement or improvement of the respective property (real or personal, and whether through the direct purchase of property or the Equity Interest of any person owning such property) permitted under this Agreement in order to finance such acquisition, lease, construction, repair, replacement or improvement, in an aggregate principal amount that at the time of, and after giving effect to, the incurrence thereof, together with the aggregate amount of any other Indebtedness outstanding pursuant to this Section 6.01(i), would not exceed the sum of (x) the greater of \$5,000,000 and 0.046 times EBITDAR calculated on a Pro Forma Basis for the then most recently ended Test Period and (y) Capitalized Lease Obligations in respect of the hangar known as “Building B” at Minneapolis-Saint Paul International Airport, in the case of this clause (y), in an aggregate amount not to exceed \$15,000,000 at any one time outstanding, and (ii) any Permitted Refinancing Indebtedness in respect thereof;”.

Section 2. **Representations and Warranties.** Each Loan Party represents and warrants to the Lenders as of the Amendment No. 1 Effective Date that:

(a) (i) Such Loan Party (A) is a limited liability company duly organized, validly existing and in good standing under the laws of the jurisdiction of its organization and (B) has the power and authority to execute and deliver this Amendment and to perform its obligations under this Amendment and the Amended Credit Agreement, (ii) the execution and delivery of this Amendment and the performance of this Amendment and the Amended Credit Agreement has been duly authorized by all required limited liability company action and (iii) this Amendment has been duly executed and delivered by such Loan Party and this Amendment and the Amended Credit Agreement constitute the legal, valid and binding obligations of such Loan Party enforceable in accordance with their terms, subject to (x) the effects of bankruptcy, insolvency, moratorium, reorganization, fraudulent conveyance or other similar laws affecting creditors' rights generally, (y) general principles of equity (regardless of whether such enforceability is considered in a proceeding in equity or at law) and (z) implied covenants of good faith and fair dealing.

(b) None of the execution or delivery of this Amendment or the performance by such Loan Party of this Amendment and the Amended Credit Agreement or the compliance with the terms and provisions hereof and thereof will violate (i) any provision of law, statute, rule or regulation applicable to such person, (ii) the certificate or articles of organization or formation or other constitutive documents (including any limited liability company or operating agreements) of such person, (iii) any applicable order of any court or any rule, regulation or order of any Governmental Authority or (iv) any agreement or other instrument to which such person is a party or by which any of them or any of their property is or may be bound, where any such violation, in each case, would reasonably be expected to have, individually or in the aggregate, a Material Adverse Effect.

(c) No action, consent or approval of, registration or filing with or any other action by any Governmental Authority is or will be required for the execution or delivery of this Amendment or for the performance of this Amendment and the Amended Credit Agreement, except for (i) such as have been made or obtained and are in full force and effect or (ii) such actions, consents and approvals the failure of which to be obtained or made would not reasonably be expected to have a Material Adverse Effect.

(d) Immediately before and immediately after giving effect to this Amendment, the representations and warranties of each Loan Party set forth in the Loan Documents shall be true and correct in all material respects on and as of the Amendment No. 1 Effective Date, with the same effect as though made on and as of such date; provided that to the extent such representations and warranties expressly relate to an earlier date, such representations and warranties shall be true and correct in all material respects as of such earlier date.

(e) Immediately before and immediately after giving effect to this Amendment, no Default or Event of Default has occurred and is continuing.



Section 3. **Conditions to Effectiveness of Amendment**. This Amendment shall become effective on the date (the "**Amendment No. 1 Effective Date**") when, and only when, each of the following conditions have been satisfied (or waived) in accordance with the terms herein:

(a) The Administrative Agent shall have received from (i) the Required Lenders, (ii) Holdings and (iii) the Borrower a duly executed counterpart of this Amendment signed on behalf of such party (which may include facsimile or other electronic transmission of a signed signature page of this Amendment).

(b) The Borrower shall have paid (i) all reasonable, documented and invoiced fees payable to the Administrative Agent or any affiliate thereof as agreed between Administrative Agent and the Borrower and (ii) all reasonable fees, expenses and disbursements of Cahill Gordon & Reindel LLP, as counsel for the Administrative Agent, incurred in connection with the preparation, negotiation and execution of this Amendment to the extent invoiced at least three (3) Business Days prior to the date hereof.

Section 4. **Acknowledgment and Agreement**. The Administrative Agent and the Required Lenders hereby acknowledge and agree that, notwithstanding anything to the contrary in the Credit Agreement prior to the Amendment No. 1 Effective Date, the amendment to the Credit Agreement set forth in Section 1 above shall be deemed to have been in effect since the Closing Date for purposes of determining whether any Default or Event of Default is continuing as a result of, or related to, the existing Capitalized Lease Obligations in respect of the hangar known as "Building B" at Minneapolis-Saint Paul International Airport.

Section 5. **Counterparts**. This Amendment may be executed in any number of counterparts and by different parties hereto on separate counterparts, each of which when so executed and delivered shall be deemed to be an original, but all of which when taken together shall constitute a single instrument. Delivery of an executed counterpart of a signature page of this Amendment by facsimile or other electronic transmission shall be effective as delivery of a manually executed counterpart hereof.

Section 6. **Governing Law**. THIS AMENDMENT AND ANY CLAIMS, CONTROVERSY, DISPUTE OR CAUSES OF ACTION (WHETHER IN CONTRACT OR TORT OR OTHERWISE) BASED UPON, ARISING OUT OF OR RELATING TO THIS AGREEMENT OR THE AMENDED CREDIT AGREEMENT (OTHER THAN AS EXPRESSLY SET FORTH IN OTHER LOAN DOCUMENTS) SHALL BE CONSTRUED IN ACCORDANCE WITH AND GOVERNED BY THE LAWS OF THE STATE OF NEW YORK, WITHOUT REGARD TO ANY PRINCIPLE OF CONFLICTS OF LAW THAT COULD REQUIRE THE APPLICATION OF ANY OTHER LAW.

Section 7. **Headings**. The headings of this Amendment are for purposes of reference only and shall not limit or otherwise affect the meaning hereof.

Section 8. **Effect of Amendment**. Except as expressly set forth herein, this Amendment shall not by implication or otherwise limit, impair, constitute a waiver of or otherwise affect the rights and remedies of the Lenders or the Administrative Agent under the Credit Agreement or any other Loan Document, and shall not alter, modify, amend or in any way affect any of the terms, conditions, obligations, covenants or agreements contained in the Credit Agreement or any other provision of the Credit Agreement or any other Loan Document, all of which are ratified and affirmed in all respects and shall continue in full force and effect. Each of

the Loan Parties confirms and agrees that the Liens granted pursuant to the Security Documents to which it is a party shall continue without any diminution thereof and shall remain in full force and effect on and after the date hereof. For the avoidance of doubt, on and after the Amendment No. 1 Effective Date, this Amendment shall for all purposes constitute a Loan Document.

*[Signatures begin on the following page]*

IN WITNESS WHEREOF, the parties hereto have caused this Amendment to be duly executed as of the date first above written.

SCA ACQUISITION, LLC

By: /s/ Jude Bricker

\_\_\_\_\_  
Name: Jude Bricker

Title: President and CEO

MN AIRLINES, LLC

By: /s/ Jude Bricker

\_\_\_\_\_  
Name: Jude Bricker

Title: President and CEO

[MN Airlines - Amendment No. I]

BARCLAYS BANK PLC, as Administrative Agent and as a  
Lender

By: /s/ Joseph Jordan

Name: Joseph Jordan

Title: Managing Director

[MN Airlines - Amendment No. I]

AMENDED AND RESTATED  
AIRLINE OPERATING AGREEMENT AND TERMINAL BUILDING LEASE  
MINNEAPOLIS-ST. PAUL INTERNATIONAL AIRPORT

BETWEEN

METROPOLITAN AIRPORTS COMMISSION

AND

MN AIRLINES, LLC d/b/a SUN COUNTRY AIRLINES

EFFECTIVE JANUARY 1, 2019

## TABLE OF CONTENTS

	<u>Page</u>
I. DEFINITIONS	1
A. DEFINITIONS	1
B. HEADINGS AND CROSS REFERENCES	14
II. TERM	14
III. USE OF THE AIRPORT	14
A. AIRLINE RIGHTS	14
B. EXCLUSIONS, RESERVATIONS, AND CONDITIONS	18
C. USE OF THE INTERNATIONAL ARRIVALS FACILITY	22
D. USE OF COMMON USE SPACE AND PUBLIC AREAS	25
IV. PREMISES LEASED AND EQUIPMENT LICENSED HEREUNDER	25
A. LEASED PREMISES	25
B. EXCLUSIVE/PREFERENTIAL USE AREAS IN TERMINAL 1	28
C. JOINT USE SPACE-BAG CLAIM AREAS	30
D. MEASUREMENT OF SPACE	31
E. ACCOMMODATION OF OTHER AIRLINES	31
F. WIDE BODY AND BOEING 757 ACCESS	37
G. ACCESS AND RELOCATION	37
H. SHORT TERM GATES	38
I. RELINQUISHMENT OF PREMISES	39
J. OUTBOUND BAGGAGE AREAS	40
K. SURRENDER OF PREMISES	40
L. TELECOMMUNICATIONS ROOMS AND FIBER/CABLING	41
M. MONTH TO MONTH PREMISES	41
V. RENTS, FEES, AND CHARGES	41
A. GENERAL	41
B. RENTS, FEES, AND CHARGES	42
C. MONTHLY ACTIVITY REPORT	44
D. SECURITY DEPOSITS	45
E. PAYMENT PROVISIONS	46
F. NET AGREEMENT	46
G. NO OTHER FEES AND CHARGES	47
H. PASSENGER FACILITY CHARGES	47

I.	NON-WAIVER	47
J.	NON-SIGNATORY LANDING FEES	48
K.	AFFILIATED AIRLINES	48
L.	ALLIANCE PARTNERS	48
VI.	CALCULATION OF RENTS, FEES, AND CHARGES	48
A.	GENERAL	48
B.	CALCULATION/COORDINATION PROCEDURES	49
C.	LANDING FEES	50
D.	TERMINAL APRON FEES	51
E.	TERMINAL 1 BUILDING RENTS	51
F.	CARROUSEL AND CONVEYOR CHARGE	53
G.	IAF USE FEES	53
H.	YEAR-END ADJUSTMENTS OF RENTS, FEES, AND CHARGES	54
I.	REVENUE SHARING	55
J.	REVERSION TO ALTERNATE RATE STRUCTURE	56
K.	AIRLINE SERVICES PROVIDED BY MAC IN TERMINAL 1	56
L.	TERMINAL 1 COMMON USE SPACE CHARGE	58
M.	MAC-OWNED SYSTEMS AND EQUIPMENT AND UTILITIES INSURANCE COST	58
VII.	CAPITAL EXPENDITURES	59
A.	GENERAL	59
B.	CAPITAL PROJECTS SUBJECT TO MII REVIEW	60
C.	CAPITAL PROJECTS NOT SUBJECT TO MII REVIEW	60
D.	MAJORITY-IN-INTEREST WAIVER	61
E.	TERMINAL 1 OPERATIONAL IMPROVEMENTS PROGRAM	61
F.	CONCOURSE G PROJECT	61
VIII.	INSTALLATION, MAINTENANCE AND UTILITIES	62
A.	OBLIGATIONS OF MAC	62
B.	OBLIGATIONS OF AIRLINE	65
C.	OPERATION AND MAINTENANCE OF OUTBOUND BHS	66
D.	OPERATION AND MAINTENANCE OF INBOUND BHS	69
E.	PASSENGER BOARDING BRIDGES (PBBs)	73
IX.	DAMAGE OR DESTRUCTION OF PREMISES	75

A.	DAMAGE OR DESTRUCTION	75
B.	FORCE MAJEURE	76
X.	INDEMNITY AND LIABILITY INSURANCE	76
A.	INDEMNIFICATION	76
B.	LIABILITY INSURANCE	77
C.	OTHER INSURANCE	80
D.	ENVIRONMENTAL LIABILITY	80
XI.	ASSIGNMENT, SUBLETTING, AND GROUND HANDLING	84
A.	ADVANCE APPROVAL	84
B.	ASSIGNMENT	85
C.	SUBLEASE AGREEMENT	86
D.	GROUND HANDLING AGREEMENT	87
E.	BANKRUPTCY	87
XII.	DISPUTE RESOLUTION	88
XIII.	[INTENTIONALLY OMITTED]	88
XIV.	EVENTS OF DEFAULT; REMEDIES	88
A.	EVENTS OF DEFAULT	88
B.	REMEDIES	90
XV.	TERMINATION	91
A.	TERMINATION BY MAC	91
B.	TERMINATION BY AIRLINE	91
C.	TERMINATION BY GOVERNMENT TAKING	92
XVI.	GENERAL PROVISIONS	92
A.	INTERPRETATION	92
B.	COMPLIANCE WITH LAW	93
C.	ADDITIONAL FEDERAL REQUIREMENTS	94
D.	ECONOMIC NONDISCRIMINATION	99
E.	GRANTING OF MORE FAVORABLE TERMS	99
F.	CONSENTS, APPROVALS, AND NOTICES	99
G.	WAIVER	100
H.	APPLICABLE LAW AND FORUM SELECTION	100
I.	SUCCESSORS	101
J.	INSPECTION	101



K.	QUIET ENJOYMENT	101
L.	NON-LIABILITY OF AGENTS AND EMPLOYEES	101
M.	NO PARTNERSHIP OR AGENCY	102
N.	SECURITY	102
O.	SUBORDINATION TO AGREEMENTS WITH THE U.S. GOVERNMENT	104
P.	PFC ACT AND ASSURANCES	104
Q.	NO EXCLUSIVE RIGHT	105
R.	CONCERNING DEPRECIATION AND INVESTMENT CREDIT	105
S.	ATTORNEY'S FEES	105
T.	SAVINGS	105
U.	MASTER TRUST INDENTURES	105
V.	AIRLINE SPECIFIC PROVISIONS	106

---

**EXHIBITS**

A	-	Airport Layout Plan	V	-	Short Term Gates
B	-	Airfield	W	-	Ground Handling Memorandum of Understanding
C	-	Terminal 1	X	-	[Intentionally Omitted]
D	-	Terminal Apron/Terminal Ramp	Y	-	Pre-Existing Rate Structure
E	-	Terminal 2	Z	-	AIRLINE Only Provisions
F	-	Landside Area			
G	-	Other Areas			
H		[Intentionally Omitted]			
I	-	BHS Exhibits			
J	-	Premises			
I	-	[Intentionally Omitted]			
H	-	[Intentionally Omitted]			
M	-	Indirect Cost Center Allocations			
N	-	Illustration of Calculation of Rents, Fees, and Charges			
O	-	Initial Rentable Square Footage			
P	-	Maintenance Responsibility Matrix			
Q	-	[Intentionally Omitted]			
R	-	[Intentionally Omitted]			
S	-	[Intentionally Omitted]			
T	-	Month to Month Premises			
U	-	[Intentionally Omitted]			

MINNEAPOLIS-ST. PAUL INTERNATIONAL AIRPORT

THIS AMENDED AND RESTATED AIRLINE OPERATING AGREEMENT AND TERMINAL BUILDING LEASE, effective as of January 1, 2019, by and between the Metropolitan Airports Commission, a public corporation under the laws of the State of Minnesota (hereinafter referred to as "MAC" or "Commission"), and MN Airlines, LLC d/b/a Sun Country Airlines a corporation organized and existing under the laws of the State of Minnesota and authorized to do business in the State of Minnesota (hereinafter referred to as "AIRLINE").

WHEREAS, MAC owns and operates the Airport (as hereinafter defined) and has the power to grant rights and privileges thereto; and

WHEREAS, AIRLINE operates an Air Transportation Business (as hereinafter defined) and desires to use or lease from MAC certain premises and facilities and to acquire from MAC certain rights and privileges in connection with its use of the Airport; and

WHEREAS, AIRLINE and MAC entered into that certain Airline Operating Agreement and Terminal Building Lease, dated as of January 1, 1999 (the "Original Agreement");

WHEREAS, AIRLINE and MAC have entered into amendments to the Original Agreement (collectively, the "Amendments"; the Original Agreement as so amended by the Amendments, the "Existing Agreement");

WHEREAS, AIRLINE and MAC wish to make further amendments and modifications to the Existing Agreement; and

WHEREAS, AIRLINE and MAC have agreed to amend and restate the Existing Agreement to take into account the new amendments and modifications;

NOW, THEREFORE, in consideration of the premises and of the mutual covenants and agreements herein contained, MAC and AIRLINE agree as follows:

**I. DEFINITIONS**

**A. DEFINITIONS**

1. "Agreement" or "Lease," or "Airline Operating Agreement and Terminal Building Lease" means this Amended and Restated Airline Operating Agreement and Terminal Building Lease, which amends and restates the Existing Agreement from and after the date hereof.
2. "Affiliated Airline" or "Affiliate" means an Airline other than AIRLINE that (a) operates aircraft of 76 passenger seats or fewer at the Airport, (b) has signed an Airline Operating Agreement and Terminal Building Lease similar to the form of this Agreement or an operating permit or such other agreement to operate at the Airport as reasonably required by MAC, (c) (i) is a subsidiary, parent company, or sister company of AIRLINE, or, (ii) if such airline is not a subsidiary, parent

company, or sister company of AIRLINE, is party to an Airline Services Agreement with AIRLINE, (d) has been designated in writing by AIRLINE as an “affiliate” of AIRLINE, and (e) is ground handled exclusively by AIRLINE or AIRLINE’s subcontractor for all flights flown on behalf of AIRLINE at the Airport.

3. “Air Operations Area” and “AOA” shall be interchangeable terms and both terms shall mean any area of the Airport used or intended to be used for landing, taking off, or surface maneuvering of aircraft, including the tug drive and all other such areas shown on Exhibit A or as amended by the Executive Director in accordance with the terms hereof, within that portion of the Airport which is enclosed by fencing, walls, or other barriers and to which access is controlled through designated entry points, but excluding all exclusive leasehold areas.
4. “Air Transportation Business” means the carriage by aircraft of persons or property as a common carrier for compensation or hire, or the carriage of mail by aircraft in commerce, and activities directly related thereto, including, but not limited to AIRLINE’S frequent flier program.
5. “Airfield Cost” is calculated as set forth in Section VI.C.1.
6. “AIRLINE” means the entity that has executed this Agreement.
7. “Airline” means an entity (including AIRLINE) that operates an Air Transportation Business at the Airport.
8. “Airline Club” means an area or areas leased by the Commission to an Airline that is made available primarily for the use and enjoyment of a select group of such Airline’s, its Alliance Partners’ and its Affiliates’ passengers, including members and their guests, as well as passengers, including members (and their guests), of other Airlines under reciprocal agreements with such other Airlines.
9. “Airline Rented Space” means the aggregate of that portion of Rentable Space under lease to all Signatory Airlines.
10. “Airline Services Agreement” means any agreement between AIRLINE and any air carrier pursuant to which such air carrier provides certain air transportation services for AIRLINE under AIRLINE’s designator code.
11. “Airport” means the Minneapolis-St. Paul International Airport. The layout of the Airport is depicted in Exhibit A.
12. “Airport Bonds and Other Forms of Indebtedness” means general airport revenue bonds, general obligation bonds, commercial paper, refunding obligations, and other forms of indebtedness incurred or assumed by the Commission in connection with the ownership or operation of the Airport System and payable from MAC revenues.

13. "Airport Cost Centers" means certain areas of the Airport and the Airport System, which are also used in accounting for airport revenues and expenses and for calculating and adjusting certain rents, fees, and charges described herein, and as such areas now exist or may hereafter be modified or extended in accordance with the terms hereof, and as more particularly described below. The Airfield, Terminal 1, Terminal Apron, Terminal 2, Landside Area, IAF, and Other Areas are shown in Exhibits B, C, D, E, F, and G, which shall be updated periodically by MAC to reflect changes to Airport Cost Centers in accordance with the terms hereto.
- a. "Airfield" means the runways, taxiways, approach and clear zones, safety areas, infield areas, landing and navigational aids, and other facilities and land areas which are not leased to any entity and are required by or related to aircraft operations (landings, takeoffs, and taxiing) at the Airport and other facilities as generally shown on Exhibit B including, but not limited to, the control tower, roads, tunnels, and collection and processing facilities for deicing agents and shall include on-Airport noise abatement costs and Off-Airport Aircraft Noise Costs, but excluding any areas leased separately at any time.
  - b. "Terminal 1" means the passenger terminal buildings known as Terminal 1-Lindbergh, including Concourses A,B,C,D,E,F, and G, as shown on Exhibit C, including but not limited to, underground parking beneath Terminal 1-Lindbergh, a portion of the auto rental/parking/terminal people mover, the Ground Transportation Center (the "GTC"), skyways, the IAF (provided that, for the purpose of calculating rates and charges, IAF is a separate Airport Cost Center), the Energy Management Center, and the Airline Clubs located therein, together with additions and/or changes thereto.
  - c. "Terminal Apron" and "Terminal Ramp" shall be interchangeable terms and both terms shall mean the airport parking apron as shown on Exhibit D to the Lease, together with any additions and/or changes thereto.
  - d. "Terminal 2" means the Terminal 2-Humphrey building located on 34th Avenue South at the Airport or any replacement facility as shown on Exhibit E.
  - e. "International Arrivals Facility" or "IAF" shall be interchangeable terms and both terms shall mean the space in Terminal 1 utilized for the arrival and departure of international flights, all as more specifically depicted on Exhibit C.
  - f. "Reliever Airports" means the general aviation airports owned and operated by Commission, including but not limited to St. Paul Downtown Airport, Flying Cloud Airport, Crystal Airport, Anoka County-Blaine Airport, Lake Elmo Airport, and Airlake Airport.

- g. "Landside Area" means the upper and lower level terminal roadways, the inbound and outbound terminal roads, the commercial lane, rental car service and storage areas, a portion of the auto rental/parking/terminal people mover, rental car ready/return areas, skyways, and the automobile parking areas (except the underground parking beneath Terminal 1) at the Airport as shown on Exhibit F.
  - h. "Equipment Buildings" means the building and ground areas at the Airport provided for the storage of equipment owned and/or rented/leased by MAC including, but not limited to, shops, storage facilities, and vehicle parking areas.
  - i. "ARFF" means the building and ground areas at the Airport provided for aircraft rescue and firefighting functions.
  - j. "Police" means the building and ground areas at the Airport provided for police functions.
  - k. "Administration" means the building and ground areas at the Airport provided for MAC administration activities including, but not limited to, the general office building and the MAC offices and administrative facilities located in Terminal 1 and Terminal 2.
  - l. "Other Areas" means all other direct cost building and ground areas at the Airport provided for general aviation, cargo, aircraft maintenance, and other aviation- and nonaviation-related activities as shown on Exhibit G.
- 14. "Airport Grants" means those moneys contributed to the Commission by the United States or any agency thereof, or by the State of Minnesota, or any political subdivision or agency thereof, to pay for all or a portion of the cost of a Capital Project.
  - 15. "Airport Security Coordinator" means the employee of the MAC charged with the authority and responsibility to implement and enforce the Airport's Security Program or such employee's designated representative.
  - 16. "Airport System" means the Airport and the Reliever Airports.
  - 17. "Alliance Partner" means a foreign air carrier that operates under a code-sharing arrangement with a Signatory Airline. Alliance Partners must (a) lease no Exclusive Use Space or Preferential Use Space from MAC (any space needs to be provided by the applicable Signatory Airline on a sublease or license basis or pursuant to the code-sharing arrangement), (b) receive all gate and ticket counter accommodation by the applicable Signatory Airline, (c) be ground handled exclusively by or on behalf of the applicable Signatory Airline or its subcontractor, and (d) operate no more than 600 annual departures from the Airport.

18. "Alternate Rate Structure" means the rate structure and methodology prescribed on Exhibit Y to be used in lieu of Section V.B. and Article VI as further specified in Section VI.J.
19. "Amendments" is defined in the Recitals.
20. "Annual Gross Revenue" means rent, concessions fees or similar charges actually received during any Fiscal Year by MAC from Selected Concessions. Annual Gross Revenue shall not include "pass-through" charges such as sales taxes, utility charges, consortium fees, key money, liquidated damages, or customer facilities charges. Annual Gross Revenue shall be reduced by any amount paid to the Airport Foundation MSP by MAC for services provided at the Airport, subject to a cap of \$743,000 per year in 2019, escalating at 2% per year thereafter, which cap may be reasonably increased by the MAC unless such increase is disapproved by a Majority-In-Interest of the Signatory Airlines in accordance with the terms hereof.
21. "Auto Rental Concessions" means all auto rental companies or other business organizations operating at either Terminal 1 or Terminal 2 that lease space for rental vehicles in the parking ramps adjacent to Terminal 1 or Terminal 2 pursuant to concessions agreements with MAC.
22. "Average Daily Utilization" is defined in Section IV.H.5.
23. "Capital Cost" (or a phrase of similar import) means the sum of (a) project costs, which includes any expenditures to acquire, construct, or equip a Capital Project, together with related costs such as planning fees, architectural and engineering fees, program management fees, construction management fees, fees for environmental studies, testing fees, inspection fees, impact fees, other direct and allocable fees, and interest during construction, and (b) financing costs, if any, such as capitalized interest, costs of issuance, and funding of mandatory reserves with bond proceeds. In the case of estimates, Capital Costs also include an allowance for contingencies.
24. "Capital Outlay" means any improvement that fails to meet the cost threshold and useful life criterion necessary to qualify as a Capital Project.
25. "Capital Project" means (a) the acquisition of land or easements; (b) the purchase of machinery, equipment, or rolling stock; (c) the planning, engineering, design, and construction of new facilities; (d) the remediation of environmental contamination, including noise mitigation, or expenditures to prevent or protect against such contamination; or (e) the performance of any extraordinary, non-recurring major maintenance of existing facilities; provided, however, that any single item of the foregoing has a Capital Cost of \$100,000 or more and a useful life in excess of three years.
26. "Commission" and "MAC" shall be interchangeable terms and both terms shall mean the Metropolitan Airports Commission, a public corporation organized and operating pursuant to Chapter 500, Laws of Minnesota 1943 and amendments thereto.

27. "Concessionaires" means Food and Beverage Concessions or Merchandise Concessions.
28. "Concourse G Project" is defined in Section VII.F.
29. "Contingency Projects" is defined in Section VII.D.
30. "Contract Security" is defined Section V.D.1.
31. "Coverage Account" means the Coverage Account established and maintained pursuant to the terms of the Senior Trust Indenture.
32. "Date of Beneficial Occupancy" or "DBO" means the earlier of (a) the date on which the Commission certifies that a portion of the Premises or a Capital Project, as applicable, are available for beneficial use or (b) the date on which beneficial use is first made of such portion of the Premises or such Capital Project, as applicable; provided, however, that with respect to land and other non-depreciable assets, the date on which beneficial occupancy occurs is the date of the closing.
33. "Debt Service" means the aggregate amount of principal and interest payments made by MAC that are due and payable during the Fiscal Year on Airport Bonds and Other Forms of Indebtedness. In addition, Debt Service shall also include:
  - 1) amounts paid as prepayment of obligations, if such prepayment is deemed approved by a Majority-In-Interest of Signatory Airlines pursuant to the provisions of Section VII.B hereof,
  - or
  - 2) principal and interest in accordance with its original scheduled amortization for any prepayment made by MAC which is not deemed approved by the Majority-In-Interest of Signatory Airlines in accordance with (1) above, until such time as the original principal amount of such prepaid obligation has been recovered by MAC.
34. "Deferred Revenue Sharing Amount" shall have the meaning given to the term in Section VI.I.3.
35. "Delta" or "DELTA" means Delta Air Lines, Inc.
36. "Deplaned Passenger" means all terminating passengers and online or interline transfer passengers deplaned at the Airport, but excluding Through Passengers and Non-Revenue Passengers.



37. "Employee Screening" is defined in Section VI.K.4.
38. "Enplaned Passenger Growth Percentage" means the percentage change of Enplaned Passengers comparing the current Fiscal Year to the previous Fiscal Year, rounded to the nearest hundredth of a percent.
39. "Enplaned Passengers" means all Originating Passengers and connecting passengers boarded at the Airport, including passengers traveling on frequent flyer coupons or miles, but excluding Through Passengers and Non-Revenue Passengers.
40. "Environmental Claims" is defined in Section X.D.1.
41. "Environmental Indemnitees" is defined in Section X.D.1.
42. "Environmental Law (or Laws)" means any applicable case law, statute, rule, regulation, law, ordinance or code, whether local, state or federal, that regulates, creates standards for or imposes liability or standards of conduct concerning any element, compound, pollutant, contaminant, or toxic or Hazardous Substance, material or waste, or any mixture thereof, including but not limited to products that might otherwise be considered of commercial value, such as asbestos, polychlorinated biphenyls and petroleum products and byproducts. Such laws shall include, but not be limited to, the National Environmental Policy Act ("NEPA") 42 U.S.C. Section 4321 et seq., the Comprehensive Environmental Response, Compensation and Liability Act ("CERCLA"), 42 U.S.C. Section 9601 et seq., the Resource Conservation and Recovery Act ("RCRA"), 42 U.S.C. Section 6901 et seq., the Federal Water Pollution Control Act ("FWPCA"), 33 U.S.C. Section 1251 et seq. the Federal Clean Air Act ("FCAA"), 42 U.S.C. Section 7401 et seq., the Toxic Substances Control Act ("TSCA"), 15 U.S.C. Section 2601 et seq., the Federal Insecticide, Fungicide and Rodenticide Act ("FIFRA"), 7 U.S.C. Section 136 et seq., and any amendments thereto, as are now or at any time hereafter may be in effect, as well as their state and local counterparts, including but not limited to the Minnesota Environmental Response and Liability Act ("MERLA"), Minn. Stat. Section 115B, the Minnesota Petroleum Tank Release Clean Up Act ("MPTRCA"), Minn. Stat. Section 115C, and the Minnesota Environmental Rights Act ("MERA"), Minn. Stat. Section 116B.
43. "Environmentally Regulated Substances" means any elements, compounds, pollutants, contaminants, or toxic or Hazardous Substances, material or wastes, or any mixture thereof, regulated pursuant to any Environmental Law, including but not limited to products that might otherwise be considered of commercial value, such as asbestos, polychlorinated biphenyls, petroleum products and byproducts, ethylene glycol and other regulated materials used in de-icing operations.
44. "Essential Air Service Airline" or "EAS Airline" means a Signatory Airline that serves only essential air service destinations as such term is defined in 49 U.S.C. 41731, et. seq., as may be amended from time to time, from the Airport.

45. "Executive Director" means Commission's Executive Director/CEO or such other person designated by the Executive Director to exercise functions with respect to the rights and obligations of Commission under this Agreement.
46. "Existing Agreement" is defined in the Recitals.
47. "FAA" means the Federal Aviation Administration of the U.S. Government or any federal agencies succeeding to its jurisdiction.
48. "Facilities Construction Credit" and "Facilities Construction Credits" shall mean the amounts resulting from an arrangement embodied in a written agreement of the MAC and an Airline pursuant to which the MAC permits such Airline to make a payment or payments to the MAC which is reduced by the amount owed by the MAC to such Airline as a result of such Airline fronting and paying for the cost of construction of MAC-owned improvements under such agreement, resulting in a net payment to the MAC by such Airline. The "Facilities Construction Credit" shall be deemed to be the amount owed by the MAC under such agreement which is "netted" against the payment of rentals by such Airline to the MAC.
49. "Fiscal Year" refers to Commission's fiscal year and means the twelve-month period commencing on each January 1 and ending December 31.
50. "Flight" or "Flights" means any and all scheduled flights regardless of aircraft type.
51. "Food and Beverage Concessions" means companies or other business organizations that principally sell consumable food or beverages items, excluding vending-machine operations, to the traveling public at Terminal 1 or Terminal 2, pursuant to concessions agreements with MAC.
52. "Ground Handling" means providing airside services to an aircraft, including, but not limited to, wing walkers, marshalling, lavatory services, aircraft cleaning and maintenance, passenger ticketing, luggage transfer and providing catering supplies, but not including (a) fueling, or (b) any services provided directly to passengers (e.g. wheelchair/electric cart services) in Terminal 1 or Terminal 2, other than baggage handling and ticketing.
53. "Hazardous Substances" shall be interpreted in the broadest sense to include any and all substances, materials, wastes, pollutants, oils or governmental regulated substances or contaminants as defined or designated as hazardous, toxic, radioactive, dangerous, or any other similar term in or under any of the Environmental Laws, including but not limited to asbestos and asbestos containing materials, petroleum products including crude oil or any fraction thereof, gasoline, aviation fuel, jet fuel, diesel fuel, lubricating oils and solvents, urea formaldehyde, flammable explosives, PCBs, radioactive materials or waste, or any other substance that, because of its quantity, concentration, physical, chemical, or infectious characteristics may cause or threaten a present or potential hazard to human health or the environment when improperly generated, used, stored, handled, treated, discharged, distributed, disposed, or released. Hazardous Substances shall also mean any hazardous materials, hazardous wastes, toxic substances, or regulated substances under any Environmental Laws.

54. "Inbound BHS" means the inbound baggage handling system and carrousel in Terminal 1, as depicted on Exhibit I attached hereto.
55. "Inbound BHS Actual Cost" is defined in Section VIII.D.2.e.
56. "Inbound BHS Budgeted Cost" is defined in Section VIII.D.2.a.
57. "Indemnities" is defined in Section X.A.1.
58. "International Regularly Scheduled Airline Service" means regularly scheduled air service to an international destination with at least one arrival and one departure per week on a continuous or seasonal basis.
59. "Irregular Need" is defined in Section IV.E.2.d.
60. "Irregular Need Airline" is defined in Section IV.E.2.d
61. "Janitorial Operation and Maintenance Expenses" means costs incurred by MAC, to provide for janitorial services and window cleaning, which may include contract services, rubbish disposal, cleaning supplies, bathroom supplies, equipment, and allocated administrative expenses.
62. "Joint Use Formula" means a formula that prorates the cost of a service or space, among the Airlines actually using such service or space as follows: (a) 20 percent of the cost equally among each such Airline, and (b) 80 percent of the cost on the basis of that proportion which the number of each such Airline's Enplaned Passengers at the Airport bears to the total number of Enplaned Passengers of all such Airlines at the Airport, subject to the provisions in Section V.J and K for Affiliated Airlines and Alliance Partners. Essential Air Service Airlines and their activity will be excluded from the Joint Use Formula.
63. "Landing Fee Repair and Replacement Amount" shall be equal to 65.6 percent (65.6%) of the Repair and Replacement Amount. This allocation may be reasonably adjusted on January 1, 2020 or anytime thereafter based on increases/decreases to the Airfield cost center's book value.
64. "MAC Design and Construction Standards" mean the design and construction standards for work done in structures or on land owned or controlled by the Commission, developed by MAC under the authority of the Executive Director/CEO, pursuant to Section 5 of Ordinance 94 (or as that ordinance may be revised or amended), a copy of which is available upon request.

65. "MAC-Owned Systems and Equipment" means, collectively, those certain fixtures, equipment, systems and improvements owned by MAC and located throughout the Airport in furtherance and support of the Air Transportation Business and related operations of Airlines at the Airport, including AIRLINE, including without limitation flight information displays, baggage handling systems including automated bag drop devices, weather information displays, gate information displays, ramp information displays, baggage information displays, common use systems, resource management systems, digital content management systems, Preferential Use Space or Common Use Space kiosks, automated passport control kiosks, IP telephone systems, CCTV systems, passenger flow monitoring systems, Wi-Fi, secure access control systems, digital information displays, digital signage systems, and public address systems.
66. "MAC Policies" means statements or directives approved by the MAC Board of Commissioners and/or statements or directives approved by MAC staff upon appropriate delegation from the MAC Board of Commissioners (provided that where such statements or directives promulgated by the MAC staff are discretionary under Minnesota law, they shall not materially increase AIRLINE's obligations, or decrease AIRLINE's rights, hereunder); provided, however, that such MAC Policies shall be reasonable, lawful, and enforced in a non-discriminatory manner.
67. "Majority-In-Interest" ("MII") means the Signatory Airlines who (a) represent no less than 50 percent in number of the Signatory Airlines operating at the time of the voting action and (b) paid no less than 40 percent of landing fees incurred by Signatory Airlines during the preceding Fiscal Year. No Airline shall be deemed a Signatory Airline for the purpose of determining a Majority-In-Interest if the Commission has given written notice of an event of default to such Airline that is continuing at the time of the voting action.
68. "Maximum Certificated Gross Landing Weight" means the maximum gross landing weight in thousand-pound units based on the current FAA Type Certificate Data Sheet applicable to the particular type, design, and model of aircraft.
69. "Merchandise Concessions" means companies or other business organizations that principally sell retail or news products, excluding automated vending items, to the traveling public at Terminal 1 or Terminal 2, pursuant to concessions agreements with MAC.
70. "Net Airfield Cost" is calculated as set forth in Section VI.C.2.
71. "Net Revenues" has the meaning provided for in the Senior Trust Indenture.
72. "Non-Revenue Passengers" means passengers from whom an Airline receives no remuneration or only token remuneration, including employees of an Airline and others, but excluding passengers traveling on frequent flyer coupons or miles.
73. "Off-Airport Aircraft Noise Costs" means the capital and operating costs (including legal and administrative costs), net of any amounts for off-airport aircraft noise costs received from nonsignatory Airlines and/or federal and state grants, connected to the acquiring of land or interests in land within the 2005

DNL 60 contours of the Airport, soundproofing of existing public and private schools and day care facilities, public hospitals, nursing homes, private single-and multi-family residences, and other categories of land use, and implementing other programs to prevent, reduce or mitigate non-compatible land uses within the 2005 DNL 60 contours of the Airport resulting from aircraft noise emissions from turbojet aircraft. Such costs shall also include but not be limited to liabilities or responsibilities imposed upon MAC for noise in connection with the operation or use of the Airport, or from flights to or from the Airport, or from aircraft thereon, or from takings or any other causes of action related to aircraft noise or for settlement of claims based on such causes of action.

74. "OI Program" means the multi-year construction program designed to provide significant enhancements to the Terminal 1 arrivals and departures levels, affecting many areas and functions, as approved by the MAC Board of Commissioners and described further in the annual Board-adopted Capital Improvement Program (CIP); a copy of the most recent CIP is available on the MAC website.
75. "Operation and Maintenance Expenses" (or a phrase of similar import) means, for any Fiscal Year, the costs incurred by the Commission to operate, maintain, and administer the Airport System, including but not limited to items (a) through (j) listed below, but excluding operation and maintenance reserves and amounts funding the Coverage Account.
- a. Personnel costs, including salaries and wages of Commission employees and temporary workers (including overtime pay), together with payments or costs incurred for associated payroll expenses such as life, health, accident, and unemployment insurance premiums; contributions to pension funds, retirement funds, union funds, and unemployment compensation funds; vacation and holiday pay; post-retirement benefits; and other fringe benefits;
  - b. Costs of materials, supplies, machinery and equipment, and other similar expenses, which are not capitalized under generally accepted accounting principles as evidenced by a written opinion of MAC's independent auditors;
  - c. Costs of maintenance, landscaping, decorating, repairs, renewals, and alterations, which are not reimbursed by insurance and which are not capitalized under generally accepted accounting principles as evidenced by a written opinion of MAC's independent auditors;
  - d. Costs of water, electricity, natural gas, fuel oil, telephone service, and all other utilities and services whether furnished by the Commission or furnished by independent contractors and purchased by the Commission;
  - e. Cost of operating services, including services for stormwater, airport shuttle bus, service agreements, and other cost of operating services;

- f. Costs of premiums for insurance covering the Airport System and its operations maintained by MAC pursuant to this Agreement;
  - g. Costs incurred in collecting and attempting to collect any sums for the Commission in connection with the operation of the Airport System and the write-off of bad debts;
  - h. Except to the extent capitalized, the compensation paid or credited to persons or firms engaged by the Commission to render advice and perform architectural, engineering, program management, construction management, financial, legal, accounting, testing, or other professional services in connection with the operation of the Airport System;
  - i. Except to the extent capitalized, the fees of trustees and paying agents, and all other fees and expenses incurred in order to comply with the provisions of a master or supplemental trust indentures; and
  - j. All other expenses, which arise out of the operation of the Airport System and which are properly regarded as operating expenses under generally accepted accounting principles; provided, however, that Operation and Maintenance Expenses shall not include any allowance for depreciation, payments in lieu of taxes, the costs of improvements, extensions, enlargements or betterments, or any charges for the accumulation of reserves for capital replacements.
76. "Original Agreement" is defined in the Recitals.
77. "Originating Passengers" means Airline passengers for whom the Airport is the point of origin in their air travel itinerary.
78. "Outbound BHS" means the outbound baggage handling system in Terminal 1, as depicted on Exhibit I attached hereto, the checked baggage inspection system ("CBIS"), and the Joint Use Space outbound baggage handling system.
79. "Outbound BHS Actual Cost" is defined in Section VIII.C.2.e.
80. "Outbound BHS Budgeted Cost" is defined in Section VIII.C.2.a.
81. "Passenger Facility Charges" or "PFCs" means charges authorized by 49 U.S.C. §40117, or any successor program authorized by federal law, and the rules and regulations promulgated thereunder (14 C.F.R. Part 158, hereafter the "PFC Regulations"), as they may be amended from time to time.
82. "Planned Future Use" means the planned future use contemplated for an affected portion of the Airport in the MAC Capital Improvement Program (CIP) or Long- Term Comprehensive Plan, including such bona fide plans in effect or under development at the time of a Release.

83. "Premises" means the areas at the Airport leased by AIRLINE pursuant to this Agreement, as set forth in Exhibit J and Exhibit D.
84. "Rate Differential" means the difference between the rates and charges calculated under the Alternate Rate Structure and the rates and charges calculated in accordance with the applicable terms and conditions of Articles V and VI (other than Section VI.J.).
85. "Rentable Space" means the space in Terminal 1 available for lease to Airlines, concessionaires, and other rent-paying tenants and for public automobile parking. Rentable Space for Airline-use is separated into the following categories:
  - a. "Exclusive Use Space", "Exclusive Premises" or "Exclusive Use Premises" means office space, storage areas, Airline Clubs, employee break rooms, baggage service office or other areas in Terminal 1 that may be leased by an Airline for its exclusive use and occupancy.
  - b. "Preferential Use Space" means space leased by an Airline on a preferential basis.
  - c. "Joint Use Space" means the areas designated in Section IV.A to be leased jointly by two or more Airlines.
  - d. "Common Use Space" means those holdrooms, ramps and ticket counter areas within the exclusive control and management of MAC that are made available by MAC to Airlines on a common use basis in accordance with Section III.D.
86. "Repair and Replacement Amount" means a \$22,848,274 deposit for Fiscal Year 2019, and increased by three percent (3%) per annum for each Fiscal Year thereafter compounded annually, to be made into the Repair and Replacement subaccount within the construction fund to be expended for major maintenance and minor (less than \$5 million) Capital Projects; provided, however, it shall not be used for automobile parking facilities and roadways.
87. "Requesting Airline" is defined in Section IV.E.2.c.
88. "Revenue Sharing" is defined in Section VI.I.1.
89. "Rules and Regulations and Ordinances" or "Ordinances" or "MAC Ordinances" means (a) rules, regulations, and ordinances adopted by the Commission pursuant to Minn. Stat. 473.608 et seq., and (b) rules and regulations promulgated by the MAC staff (provided that where such rules and regulations promulgated by the MAC staff are discretionary under Minnesota Law they shall not materially increase AIRLINE's obligations, or decrease AIRLINE's rights, hereunder); provided, however, that such Rules and Regulations and Ordinances shall be reasonable, lawful, and enforced in a non-discriminatory manner.

90. "Security Area" means the Security Identification Display Area, the Air Operations Area, and any other area defined by the FAA or MAC as an area of restricted access requiring display of appropriate MAC-issued or MAC-approved security identification for unescorted access rights.
91. "Security Identification Display Area" or "SIDA" (or a phrase of similar import) means that area defined as such in the Master Security Program adopted by MAC, approved by the FAA, and amended from time to time.
92. "Senior Trust Indenture" means the Master Trust Indenture dated as of June 1, 1998, as amended, between the Commission and Wells Fargo Bank, National Association (successor by merger to Wells Fargo Bank Minnesota, National Association, formerly known as Norwest Bank Minnesota, N.A.), as Trustee.
93. "Selected Concessions" means Food and Beverage Concessions, Merchandise Concessions, and Auto Rental Concessions.
94. "Short Term Gate" is defined in Section IV.H.
95. "Signatory Airlines" means Airlines that have executed agreements with the Commission substantially the same as this Agreement.
96. "Subordinate Trust Indenture" means the Master Subordinate Trust Indenture, dated as of October 1, 2000, as amended, between the Commission and Wells Fargo Bank, National Association (successor by merger to Wells Fargo Bank Minnesota, National Association), as Trustee.
97. "Term" is defined in Article II.
98. "Terminal 1 Repair and Replacement Surcharge" shall be equal to 21.9 percent (21.9%) of the Repair and Replacement Amount divided by Airline Rented Space. This allocation may be reasonably adjusted on January 1, 2020 or anytime thereafter based on increases/decreases to the Terminal 1 cost center's book value.
99. "Terminal 2 Repair and Replacement Surcharge" shall be equal to 8.7 percent (8.7%) of the Repair and Replacement Amount. This allocation may be reasonably adjusted on January 1, 2020 or anytime thereafter based on increases/decreases to the Terminal 2 cost center's book value.
100. "Terminal Apron Repair and Replacement Amount" shall be equal to 3.9 percent (3.9%) of the Repair and Replacement Amount. This allocation may be reasonably adjusted on January 1, 2020 or anytime thereafter based on increases/decreases to the Terminal Apron cost center's book value.
101. "Terminal Apron Cost" is calculated as set forth in Section VI.D.1.
102. "Terminal Building Cost" is calculated as set forth in Section VI.E.1.a.



103. "Through Passengers" means Airline passengers for whom the Airport is an intermediate stop in their itinerary between their point of origin and their point of destination, when such intermediate stop does not involve a change of aircraft and Airline is not obligated to remit a PFC to MAC for such passenger.
104. "Total Landed Weight" means the sum of the Maximum Certificated Gross Landing Weight for all aircraft arrivals over a stated period of time. Said sum shall be rounded to the nearest thousand pounds for all landing fees.
105. "Trust Indentures" means, collectively, the Senior Trust Indenture and the Subordinate Trust Indenture.
106. "Turn" means the arrival and departure of an aircraft from a gate.

## **B. HEADINGS AND CROSS REFERENCES**

References in the text of this Agreement to articles, sections, or exhibits of this Agreement, unless otherwise specified, are for convenience in reference and are not intended to define or limit the scope of any provisions of this Agreement.

## **II. TERM**

The term of this Agreement (the "Term") shall begin on January 1, 1999 and end December 31, 2023.

Notwithstanding the foregoing, in the event that MAC, in its sole discretion, determines that (1) due to actual gate expansion at Terminal 2 or proposed gate expansion at Terminal 2, as set forth in the MAC's Commission-approved Capital Improvement Plan for the Airport, the rates and charges at Terminal 1 have become, or are projected to be, inequitable in relation to those at Terminal 2, or vice versa, or (2) loss of concessions revenue (which, for these purposes, shall include in-terminal concessions, parking, and ground transportation revenues) causes rates and charges at the Airport to be unsustainable (provided that the foregoing shall not apply to temporary decreases or losses in concession revenue due to Terminal 1 or Terminal 2 renovations), then AIRLINE agrees to negotiate with MAC in good faith regarding the adjustment of rates and charges at the Airport, consistent with all applicable federal grant assurances; provided, however, that such adjusted rates and charges at the Airport shall not be effective prior to January 1, 2028. This provision is not intended to limit MAC's or AIRLINE's rights under this Agreement or any applicable law or regulation whatsoever.

## **III. USE OF THE AIRPORT**

### **A. AIRLINE RIGHTS**

AIRLINE shall have the following rights to use the Airfield, the Premises, and other areas of the Airport (to the extent necessary for any such permitted use) for the conduct of AIRLINE's Air Transportation Business at the Airport. These rights are subject to the terms of this Agreement and to MAC Rules and Regulations and Ordinances. These rights are as follows:

1. To land upon, takeoff from, and fly over the Airport using aircraft operated by AIRLINE in areas designated for such purposes by MAC.

2. To taxi, tow, and park aircraft operated by AIRLINE in areas designated for such purposes by MAC. Subject to reasonable Rules and Regulations and Ordinances, AIRLINE may operate regional jets on the Terminal Apron.
3. To provide (or have provided on its behalf) the following services for itself and any of its Affiliated Airlines or Alliance Partners and, either directly or through an Airline consortium or an approved handling agreement, for other Airlines, either by itself or in conjunction with other Signatory Airlines:
  - a. Passenger handling services, including enplaning and deplaning passengers, handling reservations, ticketing, billing, manifesting, baggage check-in, interline and lost baggage services, and other services necessary to process passengers and baggage for air travel.
  - b. Ground Handling.
  - c. Aircraft and equipment services, including services to repair, maintain, test, park, and store aircraft and ground support equipment.
  - d. Operational services, including de-icing aircraft and ramp services, dispatching and communication services, and meteorological and navigational services.
  - e. Porter services.
  - f. Security screening services; provided that the level and quality of such services shall meet or exceed the level and quality of such services at comparable airports.
  - g. Mail, freight, and express package services.
4. To train personnel in the employ, or working under the direction, of AIRLINE or of any other Airline, but only to the extent that such training is incidental to the conduct of AIRLINE's Air Transportation Business at the Airport.
5. To sell, lease, transfer, dispose, or exchange AIRLINE's aircraft, aircraft engines, aircraft accessories, other equipment, and supplies to any other party, but only to the extent that such activities are incidental to the conduct of AIRLINE's Air Transportation Business at the Airport.
6. To acquire by purchase or otherwise any goods or services required by AIRLINE in the conduct of its Air Transportation Business at the Airport from any supplier, contractor, or Signatory Airline subject to the conditions of this Agreement.

7. To install and maintain in AIRLINE's Exclusive Use Space and Preferential Use Space, at AIRLINE's sole cost and expense, signs, posters, displays, banners, pamphlets, and other materials that identify and promote the Air Transportation Business and frequent flier programs of AIRLINE or its Affiliated Airlines or Alliance Partners or luxury retailers or program partners (but, with respect to luxury retailers and program partners, only in AIRLINE's Airline Club areas, subject to the applicable terms and conditions of Section III.A.15). Such signs shall be constructed, installed and maintained consistent with professional, first class standards. AIRLINE shall not place such signs, posters, displays, banners, pamphlets and other materials outside of AIRLINE's Exclusive Use Space and Preferential Use Space without MAC's prior written consent. Any signs in violation of this Section may be removed by MAC.
8. To install, maintain and operate at no cost to MAC, alone or in conjunction with any other Signatory Airline, radio communication, computer, meteorological and aerial navigation equipment and facilities on AIRLINE's Premises; provided, however, that any such future installations shall be subject to the prior written approval of MAC (not to be unreasonably withheld).
9. To maintain and operate directly or through a subcontractor a kitchen or other plant without cost to MAC within areas leased to it at the Airport outside of Terminal 1 or Terminal 2 for the purpose of preparing and dispensing in-flight food and beverages (for consumption by passengers and crews on board aircraft of AIRLINE or any Affiliated Airline or Alliance Partner), including alcoholic beverages subject to procuring licenses and insurance therefor.
10. To install, maintain, and operate, as required by AIRLINE, customer relations, security and holdroom facilities and equipment, administrative offices, crew facilities, ready rooms, operations offices, training facilities, and related facilities, and to install personal property, including furniture, furnishings, supplies, machinery and equipment, in AIRLINE's Exclusive Use Space.
11. To have ingress to and egress from the Airport and AIRLINE's Premises for AIRLINE's and its Affiliated Airlines' and Alliance Partners' officers, employees, agents, contractors, passengers, and invitees, including furnishers of goods and services.
12. To use, for the benefit of AIRLINE's employees who perform substantially all of their work at or from the Airport, vehicular parking areas not leased by AIRLINE designated by MAC, subject to current MAC Policies and fees.
13. To obtain valet parking privileges subject to current MAC Policies and fees.
14. To install soft drink vending machines and snack vending machines in that section of AIRLINE's Exclusive Use Space which are not intended to be open to the general public and are for the sole use of AIRLINE's and its contractors' and subcontractors' officers, employees and agents. Vending machines shall not be within the view of the general public and locations of all vending machines installed after the date of this Agreement are subject to the prior written approval of MAC, acting reasonably.

15. To operate Airline Clubs in areas authorized by this Agreement subject to the following conditions: (a) AIRLINE may provide food, beverage, newspapers and magazines to Airline Club users provided that it is without charge, except that alcoholic beverages may be sold if AIRLINE pays to MAC a concessions fee in an amount equal to twelve percent (12%) of gross sales of alcoholic beverages; (b) AIRLINE may provide Airline Club users access to telephones, facsimile machines, copy machines, computers and the internet (via data ports or Wi-Fi); (c) AIRLINE may rent to Airline Club users only conference rooms that are no larger than 300 square feet each and limited to an aggregate of 1,000 square feet per Airline Club; and (d) AIRLINE must pay the portion of costs associated with the operation of MAC's consolidated loading dock for the Airline Club(s), which shall be calculated based on volume of deliveries to the Airline Club(s). AIRLINE may not install cash machines or vending machines, sell merchandise or conduct any other retail business within an Airline Club, provided, however, that the foregoing exclusion shall not apply to (w) marketing or promotion of its frequent flier program, (x) ticket sales, upgrades, or other standard ticketing services, (y) sales of memberships in a TSA approved third party registered traveler program or similar service, or (z) marketing or promotion of luxury retailers and program partners (but only at no charge to such luxury retailer or program partner) provided that such marketing or promotion of luxury retailers and program partners do not conflict with or devalue MAC's advertising concession or sponsorships as determined by MAC in its reasonable discretion. AIRLINE shall endeavor to provide MAC with notice of any such luxury retailer or program partner marketing or promotion prior to installing the same. If MAC determines, in its reasonable discretion that such luxury retailer or program partner marketing or promotion conflicts with or devalues MAC's advertising concession or sponsorship, AIRLINE shall either not install, or promptly remove, any such marketing or promotion. No other services may be provided unless prior written approval is obtained from the Executive Director. AIRLINE may charge a daily or annual membership fee paid by the users in an amount consistent with AIRLINE's practices in the United States of America or provide complimentary or reduced fee access to select customers and guests based on AIRLINE established criteria that are consistent with AIRLINE's practices in the United States of America.
16. To install telephones, facsimile machines, and other telecommunications and internet devices and conduit in AIRLINE's Premises that are not accessible to the public, subject to Section IV.L.
17. To install ramp information display systems ("RIDS") in the Premises and other areas approved by the Executive Director at no cost to MAC.
18. To install self-service ticketing devices ("SSDs"), self-service baggage drop devices, and other self-service devices, each as reasonably approved by the MAC in areas approved by the Executive Director and added to the Premises.

19. To maintain and operate without cost to MAC a reasonable amount of air conditioning equipment, including without limiting the generality thereof the operation of air conditioning truck equipment for the air conditioning of aircraft, either alone or in conjunction with other Signatory Airlines.
20. To maintain combination lunch and locker rooms in AIRLINE's Exclusive Use Space for use by AIRLINE's employees.
21. To provide, during irregular operations, its, its Affiliated Airlines' and its Alliance Partners' passengers with food and beverages at no charge.

**B. EXCLUSIONS, RESERVATIONS, AND CONDITIONS**

Except as authorized by this Agreement, AIRLINE may conduct no business on the Airport without the prior written consent of MAC.

1. Wherever under this Article III, AIRLINE or AIRLINE in conjunction with other Airlines carries on permitted operations through the agency of third persons or corporations not employees or subsidiaries of AIRLINE or of such other Airlines such third persons or corporations shall first be approved by the Executive Director in writing, which approval will not be unreasonably withheld, conditioned, or delayed.
2. MAC reserves the right to contract for the sale to the public of food, beverages (including alcoholic beverages), tobacco, merchandise, personal services, and business services within Terminal 1 and Terminal 2, and to charge for the privilege so to do. Subject to the conditions set forth below, AIRLINE hereby consents to allow any Concessionaires within the Airport, if so authorized by MAC, to deliver goods (food and alcohol included) to any customer located within AIRLINE's holdroom areas. This consent includes allowing the Concessionaires or MAC-approved contractors or subcontractors providing delivery services on behalf of the Concessionaires to enter the AIRLINE's holdroom area for the purpose of delivering goods to the customer and securing payment. AIRLINE also consents to allow vendors, deliveries, and the general public to have reasonable access, through its holdrooms, to any concessions space which requires such access. The foregoing consent is given subject to the following conditions:
  - a. MAC shall not allow any use of AIRLINE's holdroom areas by any Concessionaire or MAC-approved contractors or subcontractors providing delivery services on behalf of the Concessionaires in any way that could, as reasonably determined by AIRLINE, adversely impact AIRLINE's conduct of its airline operations from such holdrooms. At AIRLINE's request, MAC shall limit or modify Concessionaire's or MAC-approved contractors' or subcontractors' providing delivery services on behalf of the Concessionaires activities in AIRLINE's holdroom areas if necessary to prevent interference with AIRLINE's operations in or from such areas.

- b. Prior to allowing any Concessionaires or MAC-approved contractors or subcontractors providing delivery services on behalf of the Concessionaires to AIRLINE's holdroom areas for the purposes described in this Section III.B.2, MAC shall require such Concessionaires and MAC-approved contractors or subcontractors providing delivery services on behalf of the Concessionaires to indemnify AIRLINE to the same extent such Concessionaires indemnify MAC with respect to claims and damages that arise out of Concessionaires' and MAC-approved contractors or subcontractors providing delivery services on behalf of the Concessionaires operations in AIRLINE's holdroom areas and to add AIRLINE as an additional insured to Concessionaires' and the MAC-approved contractors' or subcontractors' providing delivery services on behalf of the Concessionaires liability insurance policies required under MAC's agreement with such parties.
- c. AIRLINE shall not be obligated to indemnify, defend, or hold harmless the Indemnitees from or against the actions, negligence, or willful misconduct of any Concessionaire or MAC-approved contractors or subcontractors providing delivery services on behalf of the Concessionaires.

MAC shall not authorize any other activity by any Concessionaire or MAC-approved contractor or subcontractor providing delivery services on behalf of the Concessionaires within AIRLINE's holdroom area without first consulting with AIRLINE in good faith and giving AIRLINE a reasonable opportunity to voice any objections it may have to such activity. However, if such activity involves the construction of improvements or placement of property in the AIRLINE'S holdroom area, consent by AIRLINE will be required and may be granted or withheld in AIRLINE'S sole and absolute discretion.

- 3. MAC reserves the right to assess the following fees and charges to suppliers of goods and services:
  - a. MAC may charge suppliers, including Airlines, of in-flight food and beverages and vending unless the supplier is an Airline that is supplying itself or its Affiliated Airline or Alliance Partner, provided that such charge shall not exceed 5% of gross receipts and a reasonable annual administrative fee, for their right to provide such products and services to AIRLINE or Airlines.
  - b. MAC shall have the right to charge suppliers to AIRLINE of goods and services, fees and rentals for exclusive use of MAC property or improvements thereon leased or licensed by such entity from the MAC or, as to suppliers not under contract with AIRLINE, when their use is such as to constitute the performance of a commercial business at the Airport.

- c. MAC shall have the right to charge ground transportation companies, including AIRLINE, or ground transportation companies under agreement with AIRLINE, if regularly engaged in ground transportation business, for ground transportation of passengers or others to or from the Airport.
4. AIRLINE shall take all reasonable steps within its control so as not to unreasonably interfere with the effectiveness or accessibility of the drainage and sewage system, electrical system, air conditioning system, fire protection system, sprinkler system, alarm system, fire hydrants and hoses, if any, installed or located on or within the Premises or the Airport.
5. AIRLINE shall not do or authorize to be done any act upon the Airport that will invalidate or conflict with any fire or other casualty insurance policies of MAC covering the Airport or any part thereof.
6. AIRLINE shall not dispose of or authorize any other person to dispose of any waste material taken from or products used (whether liquid or solid) with respect to its aircraft into the sanitary or storm sewers at the Airport unless such waste material or products are disposed of pursuant to Environmental Law. All such disposal shall comply with the applicable regulations of the United States Department of Agriculture and shall be in compliance with this Agreement.
7. AIRLINE shall not keep or store, during any 24-hour period, flammable liquids within the enclosed portion of the Premises in excess of AIRLINE's working requirements during said 24-hour period, except in storage facilities and containers especially constructed for such purposes in accordance with standards established by the National Board of Fire Underwriters and approved by a governmental agency with authority to inspect such facilities for safety compliance. Any such liquids having a flash point of less than 100°F shall be kept and stored in safety containers of a type approved by the Underwriters Laboratories.
8. AIRLINE shall promptly remove and dispose of any of AIRLINE'S disabled aircraft that obstruct any part of the Airport, including any parts thereof, subject, however, to any requirements or direction by the National Transportation Safety Board, the FAA, or the Executive Director that such removal or disposal be delayed pending an investigation of an accident. AIRLINE consents: that, if AIRLINE has not removed or disposed of any of AIRLINE'S disabled aircraft as set forth above, the Executive Director may take any and all necessary actions to effect the prompt removal or disposal of any of AIRLINE'S disabled aircraft that obstructs any part of the Airport; and that any costs incurred by or on behalf of MAC for any such removal or disposal of any of AIRLINE'S aircraft shall be paid by AIRLINE to MAC; that any claim for compensation against MAC, and any of its officers, agents, or employees, for any and all loss or damage sustained to any such disabled aircraft, or any part thereof, by reason of any such removal or disposal is waived; and that AIRLINE shall indemnify, hold harmless, and defend MAC, and all of its officers, agents, and employees against any and all liability for injury to or the death of any person, or for any injury to any property arising out of such removal or disposal of said aircraft.

9. Unless otherwise authorized by this Agreement, AIRLINE shall not maintain or operate on the Airport a cafeteria, restaurant, bar, or cocktail lounge, stand, or any other facility for the purpose of providing (and AIRLINE shall not otherwise provide) food, beverages, tobacco, or merchandise for sale to the public. Notwithstanding the foregoing, during irregular operations, AIRLINE may provide its passengers with food and beverages at no charge.
10. MAC has provided for underground aircraft fueling facilities under agreements with Airlines and other users which agreements control as to installation, maintenance, and operation of the fueling facilities on the Terminal Apron and the Airport.
11. MAC may prohibit the use of the Airfield or Terminal Apron by any aircraft operated or controlled by AIRLINE which exceeds the design strength of the paving of the Airfield or Terminal Apron facilities, so long as such prohibition also extends to similar aircraft operated by other Airlines.
12. Except as otherwise authorized by this Agreement, AIRLINE shall not install, maintain or operate in Terminal 1 or Terminal 2, or authorize the installation, maintenance, or operation in Terminal 1 or Terminal 2, of any vending machine or device designed to dispense or sell food, beverages, tobacco, or merchandise of any kind.
13. Access to or egress from the Airport and the AIRLINE's Premises shall not be used, enjoyed, or extended to any person engaging in any activity or performing any act or furnishing any service for or on behalf of AIRLINE that is not authorized under the provisions of this Agreement unless expressly authorized by MAC.
14. Subject to AIRLINE's consent and AIRLINE's rights and obligations hereunder, MAC retains the right to install all public telephones, facsimile machines, and other telecommunications devices and conduit in the Premises leased to AIRLINE, and to collect the proceeds therefrom.
15. MAC may designate points at which all-cargo flights may load and unload.
16. Except as otherwise authorized by this Agreement, AIRLINE shall not sell, take orders for, or deliver duty free merchandise and international travel merchandise on any outbound flight from the Airport under a program in which AIRLINE solicits or accepts order for purchase by passengers of duty free merchandise at any time prior to the departure of AIRLINE's aircraft on the outbound flight from the Airport.
17. AIRLINE shall not contract to provide Ground Handling services and shall not permit the use of its Premises through a Ground Handling agreement except in accordance with the terms and conditions of this Agreement.



18. Except as otherwise provided in this Agreement, MAC reserves the right to place advertising or sponsorship displays in all areas of the Airport, except within AIRLINE's Exclusive Use Space or on any equipment owned by Airline; provided, however, that (a) any MAC advertising display shall not unreasonably interfere with the use of AIRLINE's Premises by AIRLINE, or its Affiliates or Alliance Partners, and (b) AIRLINE shall have the right to disapprove of any and all advertising proposed in its Preferential Use Space in AIRLINE's sole and absolute discretion, subject to the procedure herein. With respect to proposed advertisements in AIRLINE's Preferential Use Space, MAC shall provide AIRLINE with the location of the proposed advertising, drawings and specifications for the proposed advertising, and such other information as reasonably requested by AIRLINE to review such proposed advertising. Within 30 days' after AIRLINE's receipt of the foregoing information for such proposed advertising, AIRLINE shall respond whether it approves or disapproves, in its sole and absolute discretion, such advertising. AIRLINE's failure to respond shall be subject to notice and cure as and to the extent provided hereunder, but, in no event, shall AIRLINE be deemed to have approved any such advertising due to its failure to respond within the required time period. If AIRLINE does not expressly approve such proposed advertising, such proposed advertising shall not be installed in AIRLINE's Preferential Use Space. AIRLINE shall not sell any advertising space anywhere within the Airport, including but not limited to within its Leased Premises or on any information display equipment that AIRLINE may own, whether such equipment is located within AIRLINE's Leased Premises or not, unless otherwise agreed by MAC in its sole and absolute discretion.

#### **C. USE OF THE INTERNATIONAL ARRIVALS FACILITY**

MAC will control prioritization and utilization of the IAF and associated gates for international arrivals by Airlines and may develop prioritization procedures not inconsistent with the terms of this Agreement.

1. In order to use the International Arrivals Facility, AIRLINE must obtain and maintain all necessary government approvals to operate such international Flights. AIRLINE shall provide MAC all reasonably necessary information and copies of government approvals including scheduling, inter-line, code-share or other information, upon request. MAC retains the right to verify the status of AIRLINE to determine whether AIRLINE qualifies to use the IAF. Other than DELTA international Flights which shall be accommodated at Terminal 1 unless otherwise agreed to by DELTA, MAC will determine to which terminal to assign an international Flight. In making such determination, MAC will consider reasonable factors, including but not limited to:
  - a. If such Airline is a Signatory Airline;
  - b. If such Airline leases Exclusive Use Space or Preferential Use Space at Terminal 1;
  - c. If such Airline has an inter-line or code-share agreement with a Signatory Airline operating at Terminal 1 on a Preferential Use gate;

- d. If such Airline is providing International Regularly Scheduled Airline Service;
  - e. If such international Flight is seasonal or year-round;
  - f. Input from US Customs and Border Control; and
  - g. Gate, ramp, and ticket counter availability.
2. Gates G1 through G10 and associated passenger loading bridges, ramp access and lobby and baggage facilities on Concourse G currently leased by DELTA are available for access to the International Arrivals Facility based on the following priority of use:
    - a. International Regularly Scheduled Airline Service.
    - b. DELTA or a DELTA Affiliated Airline domestic arrivals and departures.
    - c. Non-scheduled irregular or delayed international charter arrivals when the expected delay for the flight to use the Terminal 2 facility will exceed 90 minutes and the use of an IAF gate will not interfere with the scheduled use of that gate. Such interference shall be defined as the overlap of the non-scheduled use with the scheduled use such that the scheduled flight will have to be relocated to another concourse for its operation or will have to wait for a gate due to the unavailability of any gate. DELTA has committed to MAC to designate an individual on site to give necessary approvals.
  3. So long as DELTA leases gates G1-G10 or any supplemental or replacement gates and unless otherwise agreed by MAC and DELTA, DELTA has committed to MAC that it shall provide all Ground Handling at the IAF gates subject to either (i) air carrier self-handling rights contained in AIP grant assurances, at rates that do not exceed those specified in the applicable IATA ground handling agreement, or (ii) the authorized use of a third party ground handling company to provide Ground Handling at the IAF gates upon a requesting airline executing the memorandum of understanding included as Exhibit W. Further, so long as DELTA leases gates G1-G10 or any supplemental or replacement gates and unless otherwise agreed by MAC and DELTA, DELTA has committed to MAC to provide Airlines with reasonable access to DELTA data and communications systems at gates G1-G10; provided, however, that Airlines shall not have a right to utilize DELTA's computer equipment, make alterations to the gate holdroom or millwork, or use any system or equipment that DELTA reasonably determines may jeopardize or interfere with DELTA's operations.
  4. So long as DELTA leases gates G1-G10, no Airline aircraft, other than a DELTA aircraft, will remain on gates G1-G10 over two hours if a narrow-body or three hours if a wide-body. So long as DELTA leases gates G1-G10 or any supplemental or replacement gates and unless otherwise agreed by MAC and DELTA, DELTA has committed to MAC that it will coordinate any moving of aircraft with MAC's operations department, FAA and appropriate federal inspections agencies.

5. AIRLINE, if it self-handles, or DELTA, if it provides Ground Handling to AIRLINE, on gates G1-G10, shall handle and dispose of all international waste on AIRLINE's aircraft in accordance with the requirements of the United States Department of Agriculture.

So long as DELTA leases gates G1-G10 or any supplemental or replacement gates and unless otherwise agreed by MAC and DELTA, DELTA has committed to MAC that it will perform all maintenance, repair, and operation of MAC jet bridges provided by MAC as part of the IAF as and to the extent set forth in Section VIII.E. So long as DELTA leases gates G1-G10 or any supplemental or replacement gates and unless otherwise agreed by MAC and DELTA, DELTA has committed to MAC to make the MAC jet bridges available for use by all users of the IAF without charges in addition to those required to be paid hereunder.

6. The use by an Airline, including AIRLINE, if applicable, under this Section III. C. of a gate leased by DELTA shall be subject to the following conditions as well as applicable charges set forth herein:
- a. Any such Airline shall be responsible for the payment of all applicable fees and charges for its use of DELTA's premises pursuant to this Section III.C., including but not limited to appropriate IAF charges and overtime fees, and DELTA shall be released from any liability therefor.
  - b. Except for Airlines landing under an emergency or other irregular operation, such Airline shall have an Airline Operating Agreement and Terminal Building Lease or other agreement with MAC. Such agreement shall include a provision that provides, in connection with such Airline's use of the premises of DELTA under this Section III.C.: (i) Airline shall indemnify, defend, release, and save harmless DELTA to the same extent that Airline indemnifies, defends, releases, and saves harmless MAC through its agreement for the period of use; (ii) the insurance and indemnification obligations therein shall inure to the benefit of the DELTA for the period of use; and (iii) Airline shall (A) ensure that its agents, employees, and contractors are properly qualified prior to operating any and all equipment, (B) secure jetway doors upon completion of use, and (C) be responsible for any cost DELTA or MAC incurs due to damage caused to DELTA's or MAC's premises or equipment (e.g. passenger boarding bridge) by Airline. DELTA shall be an intended third party beneficiary of such provision. If AIRLINE uses DELTA's premises under this Section III.C., AIRLINE hereby agrees, (i) it shall indemnify, defend, release, and save harmless DELTA to the same extent that AIRLINE indemnifies, defends, releases, and saves harmless MAC through this Agreement for the period of use, (ii) its insurance and indemnification obligations herein shall inure to the benefit of DELTA for the period of the use, and (iii) AIRLINE shall (A)

- c. ensure that its agents, employees, and contractors are properly qualified prior to operating any and all equipment, (B) secure jetway doors upon completion of use, and (C) be responsible for any cost DELTA or MAC incurs due to damage caused to DELTA's or MAC's premises or equipment (e.g. passenger boarding bridge) by AIRLINE. DELTA is an intended third-party beneficiary of the foregoing sentence.
  - d. DELTA shall not be required to indemnify, defend, release, or save harmless MAC, its employees or agents with regard to any claim for damages or personal injury arising out of any other Airline's use of DELTA's premises under this Section III.C., except to the extent caused by the negligence or willful misconduct of DELTA.
  - e. DELTA shall not be liable to any Airline or any of its agents, employees, servants or invitees, for any damage to persons or property due to the condition or design or any defect in DELTA's premises used by any Airline under this Section III.C. which may exist or subsequently occur, and any such Airline, with respect to it and its agents, employees, servants and invitees shall be deemed to have expressly assumed all risk and damage to persons and property, either proximate or remote, by reason of the present or future condition or use of DELTA's premises under this Section III.C.
7. MAC shall ensure that any such Airline using DELTA's premises under this Section III.C. has in full force and effect MAC's required insurance coverages, except Airlines without a written agreement with the MAC.

**D. USE OF COMMON USE SPACE AND PUBLIC AREAS**

MAC shall have exclusive control and management of Common Use Space in accordance with this Agreement and MAC's Rules and Regulations and Ordinances. AIRLINE's, its Affiliates' and its Alliance Partners' passengers, employees, officers, invitees, contractors, subcontractors, agents, and representatives shall have the right to use the space, facilities and conveniences of the Airport provided by MAC for use by aircraft passengers and other persons, including, without limitation, the circulation space, restrooms, lobbies, concession space, and other like facilities; provided, however, that such use (1) shall be in common with others authorized to so use such facilities, space, and conveniences, (2) shall be only at the times, to the extent and in the manner for which they are made available for use, and (3) shall be subject to applicable security directives and requirements and MAC's Rules and Regulations and Ordinances.

**IV. PREMISES LEASED AND EQUIPMENT LICENSED HEREUNDER**

**A. LEASED PREMISES**

1. For the Term of this Agreement, MAC, in consideration of the compensation, covenants, and agreements set forth herein to be kept and performed by AIRLINE, hereby leases to AIRLINE, upon the conditions set forth in this Agreement, the Premises in Terminal 1 as described and identified in Exhibit J and the initial assignment of aircraft parking positions as described and identified in Exhibit D. AIRLINE shall lease these Premises on an Exclusive Use Space, Preferential Use Space, Joint Use Space, or Common Use Space basis as follows:

## IV. Premises Leased and Equipment Licensed Hereunder

Ground Transportation Center Offices	Exclusive Use Space
Office	Exclusive Use Space
Baggage make-up area and claim office	Exclusive Use Space
Airline Clubs	Exclusive Use Space
Operations areas	Exclusive Use Space
Enclosed storage areas	Exclusive Use Space
Ticket counter (including kiosk space)	Preferential Use Space
Holdroom	Preferential Use Space
Aircraft parking positions on Terminal Apron	Preferential Use Space
Outbound baggage area (DELTA)	Preferential Use Space
Outbound baggage belt area (other airlines)	Joint Use Space
Tug drive	Joint Use Space
Inbound baggage area	Joint Use Space
Baggage claim area	Joint Use Space
IAF sterile circulation corridor	Joint Use Space
IAF Inspections Area	Joint Use Space
IAF baggage claim	Joint Use Space
IAF ticketing and baggage recheck	Joint Use Space
Common Use Ticket Counter	Common Use Space
Common Use Holdroom	Common Use Space
Common Use Ramp	Common Use Space

MAC and AIRLINE may, from time to time, add, subject to availability, additional space to the various Premises of AIRLINE by jointly executing revised Exhibits J or D as appropriate. Space added to AIRLINE's Premises shall be subject to all of the terms, conditions, requirements, and limitations of this Agreement and AIRLINE shall pay to MAC all rents, fees, and charges applicable to such additional space in accordance with the provisions of this Agreement.

- MAC shall provide, repair, and maintain the following fixtures, equipment and services within Common Use Space: computer equipment, holdroom podium and seating, utilities, ticket counters, aircraft parking areas, non-proprietary signage, snow removal, and cleaning of the holdroom and ticketing area. MAC may, but is not required to, provide ticketing kiosks and automated bag drop devices for the Common Use Space.
- MAC-Owned Systems and Equipment. MAC hereby grants to AIRLINE a limited non-exclusive license to use, subject to MAC's control and maintenance, all current and future MAC-Owned Systems and Equipment at the Airport in the ordinary course of its business at the Airport and otherwise in accordance with this Agreement. Subject to MAC's obligations herein, AIRLINE agrees to accept and use the MAC-Owned Systems and Equipment in "as is" condition, without any representations or warranties of any kind whatsoever, except to the extent

expressly set forth herein, from MAC as to any matters concerning the MAC-Owned Systems and Equipment, and further agrees to assume all risk of loss, damage and injury arising out of, or alleged to have arisen out of, AIRLINE's use of the MAC-Owned Systems and Equipment except to the extent arising from the negligence or willful misconduct of MAC or any of its contractors, or subcontractors or any of their respective employees, agents, or representatives; provided, however, that if (a) AIRLINE suffers damages due to the negligence or willful misconduct of MAC or its employees in connection with the MAC-Owned Systems and Equipment, and (b) a Majority-In-Interest of Signatory Airlines disapprove the purchase of a policy under Section VI.M that would have provided insurance coverage for such damages and as a result such damages are not covered by insurance, AIRLINE hereby waives any claim it may have against MAC or its employees for such damages to the extent they would have been covered by the aforementioned insurance. AIRLINE hereby waives all claims to special, indirect, and consequential damages, which shall include but not be limited to, losses of use, income, profit, financing, business and reputation, that might be asserted by AIRLINE against MAC or its commissioners, officers, employees, or directors, in connection with MAC's providing or maintaining the MAC-Owned Systems and Equipment, except (a) to the extent such damages arise from the gross negligence or willful misconduct of MAC or its commissioners, officers, directors, or employees, in which case AIRLINE may recover from parties and in amounts in accordance with common law unaltered by this Agreement, or (b) damages recoverable under insurance policies described herein, or would have been so recoverable if insurance had been properly maintained in accordance with this Agreement. The foregoing shall not waive any rights or obligations under Minnesota Statutes Section 466.01 *et seq.* or limit any other form of immunity available to MAC or its commissioners, officers, employees, or directors under law or at equity. All content and data feeds on MAC-Owned Systems and Equipment shall be subject to MAC control and written approval, not to be unreasonably withheld, conditioned, or delayed; provided however, that the foregoing shall not be deemed to grant MAC any license or right to use AIRLINE's intellectual property without AIRLINE's authorization. MAC during the Term of this Agreement shall, in accordance with applicable statutes or regulations, operate, maintain, and keep in good repair the MAC-Owned Systems and Equipment and essential instruments thereof (other than (w) Preferential Use Space kiosks which shall be maintained and operated by the applicable Airline, (x) any proprietary systems owned by an Airline, (y) the Inbound BHS and the Outbound BHS so long as they are being maintained by DELTA, and (z) PBBs which shall be maintained and operated as described further herein). MAC shall make repairs thereto, though caused by negligence of AIRLINE or its employees, agents, or invitees, and MAC may recover from AIRLINE such portion of the cost of such repairs caused by negligence of AIRLINE or its employees, agents, or invitees as is not recoverable through MAC's insurance on such damaged or destroyed structures or facilities.

**B. EXCLUSIVE/PREFERENTIAL USE AREAS IN TERMINAL 1**

1. Subject to the terms and conditions hereof and MAC's obligations and express representations and warranties, if any, herein, MAC will provide existing space to AIRLINE in "as is" condition. MAC will provide the following for any newly constructed space and for space that is significantly remodeled by MAC (whether paid for by MAC or AIRLINE), in accordance with MAC Design and Construction Standards and applicable codes:
  - a. Terminal Building - Main Floor (ticketing area).
    - 1) Finished flooring, finished ceiling, entrance doors and walls enclosing gross rental area. The floor immediately behind ticket counter shall be surfaced with terrazzo flooring or an equivalent alternative upon which AIRLINE may install resilient matting.
    - 2) Conditioned air.
    - 3) Standard lighting fixtures installed and maintenance thereof exclusive of relamping and/or relocation.
    - 4) Finished accessible ticket counter shell or sectional unit (front, top, ends and turrets; AIRLINE to provide inserts.
    - 5) Uniform lighting fixture and airline identification signage suspended over ticket counter; content to be supplied by AIRLINE and subject to MAC's reasonable approval; maintenance of fixtures including re-lamping.
    - 6) Digital displays on wall directly behind the ticket counter AIRLINE to provide content. Material displayed shall be subject to the approval of MAC.
    - 7) Electrical service (120V – 208 AC, 3 phase, 4 wire) to panel within leased space, data conduit and wiring. All other wiring, conduits, ducts and outlets in this space to be installed by AIRLINE.
  - b. Terminal Building - Offices.
    - 1) Finished flooring, finished ceilings, entrance doors and walls enclosing gross rental area.
    - 2) Conditioned air.
    - 3) Standard lighting fixtures installed and maintenance thereof exclusive of relamping and/or relocation.
    - 4) Electrical service (120V-AC) through duplex receptacles about ten feet apart along walls enclosing gross rental area. All other wiring, conduits and fittings to be installed by AIRLINE.

- c. Terminal Building - Operations and baggage make-up areas.
  - 1) Finished concrete floors, exposed concrete structure above, standard pedestrian and manual overhead doors in unpainted concrete block walls enclosing gross rental area.
  - 2) Standard lighting fixtures installed and maintenance thereof exclusive of relamping and/or relocation.
  - 3) Electrical service (120V - 208 AC, 3 phase, 4 wire) to panel within or adjoining leased space; 120V electrical service through duplex receptacles about 15 feet apart (48 inches above floor) along walls enclosing gross rental area. All other wiring, conduits and fittings to be installed by AIRLINE.
  - 4) Heating and ventilation.
- d. Concourses - Operations Areas.
  - 1) Finished concrete floors, exposed structure above, exterior walls, standard pedestrian and manual overhead doors, and unpainted concrete block enclosing leased area.
  - 2) Standard lighting fixtures installed and maintenance thereof exclusive of relamping and/or relocation.
  - 3) Electrical service (120V - 208 AC, 3 phase, 4 wire) to panel within or adjoining enclosed leased space. All other wiring, conduit, duct, fittings and outlets in this space to be installed by AIRLINE.
  - 4) Cold and hot water and sanitary sewer service to designated point within gross rental area, to which AIRLINE may connect and install fixtures at AIRLINE's expense.
  - 5) Standard fin-tube radiation, unit heaters, VAV boxes and steam and/or hot water for heating gross rental area. Packaged air conditioning units and distribution duct work for previously designated areas.
- e. Concourses - Gate Lobbies.
  - 1) Finished carpeted floor, finished ceilings, and painted block walls enclosing lobby.
  - 2) Conditioned air.
  - 3) Standard lighting fixtures installed and maintenance thereof including relamping.



- 4) Electrical service (120V-AC) through duplex receptacles about 10 feet apart along walls enclosing gross rental area. All other wiring, conduit and fittings to be installed by AIRLINE.
2. AIRLINE will provide the following for its Exclusive Use Space and Preferential Use Space in both the main terminal building and the concourses, in addition to installation and maintenance required of the AIRLINE under Subparagraph 1 above, in accordance with MAC Design and Construction Standards and applicable codes, for newly constructed space and for any space that is significantly remodeled:
    - a. All partitions subject to MAC approval as to materials, methods of attachment and workmanship.
    - b. All utilities, including cost of all roughing-in, and all electrical, mechanical and plumbing fixtures for exclusive use of AIRLINE, except as provided above (other than for the outbound baggage area (DELTA), which will be provided by the MAC).
    - c. All furniture, equipment and fixtures necessary for the conduct of AIRLINE's business, including gate lobby seating, ticket counter inserts, AIRLINE owned jet bridges, scales and baggage handling equipment (other than for the outbound baggage area (DELTA), which will be provided by the MAC), including housings and doors as required, signs and flight schedules, which shall all be subject to approval of MAC, acting reasonably.
    - d. All electrical energy consumed by AIRLINE, excluding lighting in baggage make-up area, gate lobbies, the outbound baggage area (DELTA) and mezzanine, to be metered separately and paid for by AIRLINE to the utilities company or MAC at rates not exceeding those published for equivalent power consumption at this location.
    - e. Electricity for lighting in outbound baggage area (DELTA), baggage make-up area, gate lobbies, and mezzanine will be provided by MAC.
    - f. All other services and supplies not provided in Paragraph 1 of this Section IV.B. All installations by AIRLINE shall conform with the requirements of applicable local, state and federal building standards, submitted for MAC approval prior to construction, and shall be performed by competent contractors acceptable to MAC, acting reasonably.

**C. JOINT USE SPACE - BAG CLAIM AREAS**

1. MAC will provide in the Joint Use Space - bag claim area, all on the ground floor, the following:
  - a. Finished floors and ceiling, finished walls, for all space excepting porter's toilet.

- b. Standard lighting and maintenance thereof including re-lamping.
  - c. Heating and mechanical ventilation of space.
  - d. Baggage claim carousels.
2. Airlines using the Joint Use Space - bag claim area will provide the following in the Joint Use Space—bag claim area, and shall pay the pro rata share of the cost thereof:
    - a. All furniture, equipment (other than baggage handling equipment) and fixtures necessary from time to time.
    - b. All other services and supplies not provided by MAC under Paragraph 1 above.

**D. MEASUREMENT OF SPACE**

In calculating the area of space to be added to or deleted from this Agreement, all measurements to determine the area of space leased or used in Terminal 1 shall be made from the primary interior surface of the exterior walls and from the centerline to centerline of each interior wall, or, in the absence of such interior wall, the point where such said centerline would be located if such interior wall existed.

**E. ACCOMMODATION OF OTHER AIRLINES**

1. Promptly upon request from MAC, AIRLINE shall provide MAC with a copy of its public schedule on file with the FAA and a gate plot showing all times when its aircraft are scheduled to be utilizing each gate within AIRLINE's Preferential Use Space ("Preferential Use Gates") or Common Use Space ("Common Use Gates") including aircraft type, projected arrival and departure times, and point of origin or destination, including activities by subtenants or airlines being accommodated.
2. In furtherance of the public interest of having the Airport's capacity fully and more effectively utilized, it is recognized by AIRLINE and MAC that from time to time during the Term of this Agreement it may become necessary for the AIRLINE to accommodate another Airline within its Premises or for MAC, acting reasonably and in accordance with the terms and conditions hereof, unilaterally to require AIRLINE to accommodate another Airline(s) within AIRLINE's Premises as required for the following:
  - a. To comply with any applicable rule, regulation, order or statute of any governmental entity that has jurisdiction over MAC, and to comply with federal grant assurances applicable to MAC.
  - b. To implement a Capital Project at the Airport.

- c. To facilitate the providing of air services at the Airport by an Airline (“Requesting Airline”) when (i) MAC does not have sufficient space available to accommodate the Requesting Airline at existing Common Use Gates or on unassigned gates, (ii) no other Airline serving the Airport is willing to accommodate the Requesting Airline’s operational needs or requirements for facilities at reasonable costs or on other reasonable terms, and (iii) MAC has determined, in accordance with the terms of Section 4 below, that AIRLINE is underutilizing its facilities or has capacity available.
  - d. To accommodate, on a short-term basis, the irregular activity (“Irregular Need”) of another Airline (an “Irregular Need Airline”) when no other Airline serving the Airport is willing to accommodate the Irregular Need of Airline. Notwithstanding the foregoing, to the extent possible, AIRLINE shall accommodate its own Irregular Need on its Preferential Use Gate(s). When such activity may not be accommodated on AIRLINE’S Preferential Use Gate(s), AIRLINE shall seek accommodation from other Airlines on its own through coordination among such Airlines’ supervisors and managers. In the event accommodation cannot be found on another Airline’s premises, AIRLINE may seek assistance from MAC. MAC’s options shall include assigning use of non-leased gate premises, assigning a remote parking location, or requiring accommodation for an Irregular Need Airline on another Airline’s Preferential Use Gate or Common Use Gate.
  - e. To accommodate a flight that has declared an emergency and such flight shall have priority over all other flight scheduling.
3. In responding to a request for facilities from a Requesting Airline or an Irregular Need Airline, MAC shall first work with the Requesting Airline or Irregular Need Airline to use existing Common Use Space or unassigned space in the same terminal as Requesting Airline operates (if applicable), if any is available.
  4. When necessary because MAC is not able to accommodate a Requesting Airline and no Airline serving the Airport is willing to accommodate the Requesting Airline’s operational needs or requirements for facilities at reasonable costs or on other reasonable terms, MAC shall make a determination as to whether any Airline has underutilized facilities or capacity available. In making such determination MAC shall act reasonably. Such determinations by MAC shall take into consideration the following:
    - a. The then existing utilization of AIRLINE’s Premises (including any requirements for spare gates and accommodation of AIRLINE’s Affiliates), the existing utilization of other Airlines of their premises, and any bona fide plan of AIRLINE or any other Airline for the increased utilization of the AIRLINE’s Premises or such Airline’s premises to be implemented within twelve (12) months thereafter (any non-public information provided by AIRLINE regarding planned or proposed routes, schedules or operations shall be treated as confidential by MAC to the maximum extent permitted by law).

- b. The need for compatibility among the current schedules and any bona fide plan of AIRLINE or another Airline to modify its schedule, including RON requirements, flight times, operations, operating procedures and equipment of AIRLINE (and its Affiliate(s)) or any other Airline and those of the Requesting Airline as well as the need for labor harmony, facilities, resources, and other relevant factors.
  - c. The following turn times and gate occupancy:  

The Requesting Airline must vacate the Preferential Use Gate(s) at least 45 minutes before the Accommodating Airline needs to commence using the Preferential Use Gate for enplaning passengers. The maximum gate occupancy by domestic narrow body aircraft for a Requesting Airline or an Irregular Need Airline shall be 45 minutes for an arrival, 45 minutes for a departure, or 1 hour and 30 minutes for a combined turn. The maximum scheduled gate occupancy by domestic wide body aircraft for a Requesting Airline or an Irregular Need Airline shall be 1 hour for an arrival, 1 hour for a departure, or 2 hours for a combined turn. The maximum gate occupancy by international narrow body aircraft for a Requesting Airline or an Irregular Need Airline shall be 1 hour for an arrival, 1 hour for a departure, or 2 hours for a combined turn. The maximum scheduled gate occupancy by international wide body aircraft for a Requesting Airline or an Irregular Need Airline shall be 1 hour and 15 minutes for an arrival, 1 hour and 15 minutes for a departure, or 2 hours and 30 minutes for a combined turn.
5. If MAC determines, using the factors above, that AIRLINE should accommodate a Requesting Airline, the following procedures shall apply:
- a. Before MAC accommodates a Requesting Airline within AIRLINE's Premises, MAC must give AIRLINE ten (10) business days prior written notice of its intent, describing the Requesting Airline's request and MAC's efforts to accommodate it. AIRLINE must accept accommodation or notify MAC within ten (10) business days after AIRLINE's receipt of such notice that it wishes to meet with MAC to show cause why the accommodation should not be made.
  - b. If, after providing notification and, if requested, meeting with AIRLINE, MAC, acting reasonably, requires AIRLINE to accommodate the Requesting Airline, AIRLINE shall determine which of AIRLINE's Preferential Use Gates and ticket counters (if needed) will be used for the accommodation and the accommodation shall continue until the earliest of the date: (i) the Requesting Airline discontinues the flight or no longer requires accommodation; (ii) a Common Use Gate or unassigned space becomes available during a time that will accommodate the Requesting Airline's requested aircraft and schedule; or (iii) another Airline is willing to accommodate the Requesting Airline.

- c. Either the Requesting Airline or AIRLINE may, six months after an accommodation commences, and no more often than once every six months thereafter, request that MAC review whether a Common Use Gate, unassigned space, or another Airline's Preferential Use Gate is available during a time that will accommodate the Requesting Airline's requested aircraft and schedule. MAC will reconsider all the factors in Section 4 in reviewing this request to relocate the Requesting Airline's operation.
  - d. During an Irregular Need, AIRLINE'S scheduled operations will have priority over any Accommodated Airline on its Premises. Notwithstanding the foregoing, in the event an Irregular Need of AIRLINE prevents its accommodation of a Requesting Airline, AIRLINE shall accommodate the Requesting Airline on another Preferential Use Gate assigned to AIRLINE when one becomes available, provided, however that AIRLINE agrees to use reasonable efforts to select a gate in close proximity to the gate originally designated by AIRLINE for the accommodation.
6. In the event that any portion of AIRLINE's Premises are used to accommodate a Requesting Airline or an Irregular Need Airline (in each such case, an "Accommodated Airline"), the following provisions shall apply:
- a. AIRLINE shall not be required to change its current or future flight schedule as published on the day MAC receives the request from the Accommodated Airline.
  - b. Any aircraft occupying a gate longer than the timeframes set forth in Section IV.E.4.c. above may be required by AIRLINE to vacate the gate to accommodate other operations. Should this occur, upon AIRLINE's request MAC will notify the Accommodated Airline as soon as MAC becomes aware of the requirement, but in any event no later than 15 minutes before the time that actual vacating is required. Failure to vacate shall result in the imposition of reasonable overtime fees by AIRLINE to the Accommodated Airline. If an Accommodated Airline does not vacate a gate as required, and AIRLINE requires the use of such gate, upon AIRLINE's request MAC shall instruct the Accommodated Airline to remove its aircraft to another location leased by the Accommodated Airline or to a remote location as designated by MAC's agent. If failure of the Accommodated Airline to remove its aircraft results in AIRLINE requiring remote parking from MAC, MAC shall invoice the Accommodated Airline for any remote parking fees that would be charged to AIRLINE, and AIRLINE shall have no liability therefor.
  - c. The Accommodated Airline shall be responsible for the payment of all applicable fees and charges for its use of AIRLINE's premises, including but not limited to appropriate FIS charges and overtime fees, and AIRLINE shall be released from any liability therefor.

- d. For the use of a Preferential Use Gate, AIRLINE shall be authorized to charge the Accommodated Airline no more than the sum of: (a) the Terminal 1 Common Use Gate Fee, and (b) a reasonable administrative fee, not to exceed fifteen percent (15%) of (a). For space other than gates, AIRLINE shall be authorized to charge the Accommodated Airline the sum of (x) the Accommodated Airline's pro-rata share of the rent and fees paid by AIRLINE for the space, and (y) a reasonable administrative fee, not to exceed fifteen percent (15%) of (x).
- e. Except for Irregular Need Airlines who are not Signatory Airlines or airlines landing under an emergency, MAC shall require the Accommodated Airline to execute an Airline Operating Agreement and Terminal Building Lease or other agreement with MAC. Such agreement shall include a provision that provides, in connection with Accommodated Airline's use of the premises of the Airline providing accommodations (the "Accommodating Airline"): (i) Accommodated Airline shall indemnify, defend, release, and save harmless the Accommodating Airline to the same extent that the Accommodating Airline indemnifies, defends, releases, and saves harmless MAC through its agreement for the period of accommodation, (ii) the insurance and indemnification obligations therein shall inure to the benefit of the Accommodating Airline for the period of accommodation, and (iii) Accommodated Airline shall (A) ensure that its agents, employees, and contractors are properly qualified prior to operating any and all equipment, (B) secure jetway doors upon completion of use, and (C) be responsible for any cost Accommodating Airline or MAC incurs due to damage caused to Accommodating Airline's premises or equipment (e.g. passenger boarding bridge) by the Accommodated Airline. Accommodating Airline shall be an intended third party beneficiary of such provision. If AIRLINE is or becomes an accommodated Requesting Airline or Irregular Need Airline, in connection with its use of the Accommodating Airline's premises, AIRLINE hereby agrees, (i) it shall indemnify, defend, release, and save harmless the Accommodating Airline to the same extent that AIRLINE indemnifies, defends, releases, and saves harmless MAC through this Agreement for the period of accommodation, (ii) its insurance and indemnification obligations herein shall inure to the benefit of the Accommodating Airline for the period of the accommodation, and (iii) Airline shall (A) ensure that its agents, employees, and contractors are properly qualified prior to operating any and all equipment, (B) secure jetway doors upon completion of use, and (C) be responsible for any cost Accommodating Airline or MAC incurs due to damage caused to Accommodating Airline's premises or equipment (e.g. passenger boarding bridge) by AIRLINE. Any such Accommodating Airline is an intended third-party beneficiary of the foregoing sentence. An Accommodating Airline shall not be required to accommodate an Airline if such Airline's insurance and indemnification obligations are not satisfied. This Section shall not apply to Airlines without a written agreement with the MAC including such an Irregular Need Airline that is not a Signatory Airline or does not otherwise have any agreement with MAC or that are landing at the Airport in the event of an emergency.

- f. AIRLINE shall not be required to indemnify, defend, release, or save harmless MAC, its employees or agents with regard to any claim for damages or personal injury arising out of any Accommodated Airline's use of AIRLINE's premises, except to the extent caused by the negligence or willful misconduct of AIRLINE.
  - g. AIRLINE shall not be liable to any Accommodated Airline or any of its agents, employees, servants or invitees, for any damage to persons or property due to the condition or design or any defect in the Premises which may exist or subsequently occur, and such Accommodated Airline, with respect to it and its agents, employees, servants and invitees shall be deemed to have expressly assumed all risk and damage to persons and property, either proximate or remote, by reason of the present or future condition or use of AIRLINE'S Premises.
  - h. MAC shall be responsible for ensuring that such Accommodated Airline has in full force and effect MAC's required insurance coverages, except Airlines without a written agreement with the MAC which may include an Irregular Need Airline that is not a Signatory Airline or that are landing at the Airport in the event of an emergency.
  - i. No Accommodated Airline shall have the right to use AIRLINE's computer equipment or make physical alterations to the gate holdroom or millwork.
  - j. Without limiting any other provision of this Agreement, AIRLINE's duty to accommodate another Airline shall be conditioned on and subject to the satisfaction of all requirements of this Section IV.E.6 by the Accommodated Airline.
7. In the event of a labor stoppage or other event which results in the permanent cessation or substantial reduction in AIRLINE's flights at the Airport, AIRLINE will immediately take all reasonable efforts, including but not limited to, moving of aircraft or equipment, providing access to AIRLINE's holdrooms and jet bridges or anything else in AIRLINE's control, in order to accommodate the operations of other Airlines providing air service to the Airport; provided that: (a) AIRLINE at all times will have access to its Premises and equipment for operational reasons and (b) AIRLINE shall not be required to take any action which would interfere with its ability to re-institute service upon cessation of labor stoppage or other event. Subject to a mutually acceptable agreement between MAC and AIRLINE covering such use, AIRLINE shall have the right to charge the fees set forth in Section IV.E.6.d. above and to require reasonable advance payment for such use of AIRLINE's gates, holdroom areas, and loading bridges.

8. Except as expressly set forth herein, the foregoing shall not be deemed to abrogate, change, or affect any restrictions, limitations or prohibitions on assignment or use of the AIRLINE's Premises by others under this Agreement and shall not in any manner affect, waive or change any of the provisions thereof.

**F. WIDE BODY AND BOEING 757 ACCESS**

Notwithstanding any other provisions in this Agreement, so long as DELTA leases such gates and unless otherwise agreed by MAC and DELTA, DELTA has committed to MAC that it will accommodate the requirements of any Requesting Airline for scheduled wide body or Boeing 757 (or similarly sized aircraft) service at one of its gates within Terminal 1, provided that: (1) Requesting Airline must not be able physically to accommodate such wide body or Boeing 757 (or similarly sized aircraft) service on any of its own leased premises; and (2) MAC will make all reasonable efforts to provide access for any narrow body aircraft operated by DELTA which is displaced. Any such Airline accommodated by Delta shall be deemed an "Accommodated Airline" and shall be subject to the applicable provisions of Section IV.E.6. above.

**G. ACCESS AND RELOCATION**

MAC shall have the right at any time or times to (a) close, relocate, reconstruct, change, alter, or modify any means of access to or egress from the Airport or AIRLINE's Premises, and (b) relocate AIRLINE's Premises in connection with the OI Program or other MAC Commission-approved Capital Improvement Program, either temporarily or permanently; provided that MAC provides reasonable notice to AIRLINE and that a reasonably convenient and adequate means of access, ingress, and egress or replacement portion of Premises, as applicable, shall exist or be provided in lieu thereof. This right is subject to the following conditions:

1. There shall not be a net increase in AIRLINE's Premises without AIRLINE's consent.
2. MAC must consult with AIRLINE to take any Premises away from AIRLINE.
3. Reasonable replacement facility space shall be provided.
4. Cost of work including Capital Costs associated with reestablishing AIRLINE's "in-kind" facilities, shall be borne by MAC and allocated to the appropriate cost center.
5. MAC shall compensate AIRLINE for the unamortized cost of any leasehold improvements to the extent that such improvements cannot be reused by AIRLINE in AIRLINE's new or existing space at the Airport.
6. If loss of space is 60 days or less there shall be no rent adjustment. If loss of space is temporary but greater than 60 days, AIRLINE's rent will be proportionately abated and the amount of the rent abatement shall be allocated to the appropriate cost center. If the loss of space is permanent, the Premises and corresponding rent shall be adjusted by a written lease amendment executed by the parties.



## H. SHORT TERM GATES

The holdrooms, aircraft parking positions and operations space associated with gates as shown on Exhibit V (hereinafter referred to as “Short Term Gates”) shall be made available to Airlines on the following basis in order to promote Airport access on fair and reasonable terms:

1. AIRLINE shall lease Short Term Gate space under its control on the same basis as provided in this Agreement, except as provided in this Section.
2. MAC may, in its discretion, cancel the lease of a Short Term Gate leased by AIRLINE if an Airline is proposing to add additional air service and desires to lease a gate directly from MAC or MAC needs to convert a Short Term Gate to Common Use Space to accommodate such additional air service. The following procedures shall be followed before a Short Term Gate lease may be cancelled:
  - a. If an Airline is proposing to add additional air service and desires to lease a gate directly from MAC, MAC may in its discretion issue a notice to AIRLINE cancelling the lease of the applicable Short Term Gate. Such notice may become effective no earlier than ninety (90) days after it is delivered.
  - b. In the event of a decision to cancel a Short Term Gate, MAC will work with AIRLINE in good faith to accommodate AIRLINE’s schedule pursuant to the procedures of Section IV.E.
  - c. MAC may extend the time periods set forth in this provision for good cause, e.g. the unavailability of replacement jet bridges or other ground equipment.
3. In the event MAC cancels the lease of a Short Term Gate pursuant to this Section IV.H., it shall compensate AIRLINE for the unamortized cost of improvements made to the leased premises of a Short Term Gate. AIRLINE shall retain and remove AIRLINE property (e.g. jet bridge or other ground equipment, computers, inserts) or may negotiate their sale.
4. The appearance of a Short Term Gate shall be “generic” i.e. generic carpet, neutral wall finishes and no distinguishing colors on the podium or backwall except as to improvements existing as of the date of this Agreement. AIRLINE may hang corporate banners or posters and name identification signs so long as they can be detached without significantly damaging the premises or AIRLINE commits to restoring the premises without cost to MAC.

5. If AIRLINE is leasing only one gate, MAC will not cancel the lease on such gate until all other Short Term Gates (excluding B14, B16, D1, D5) have been reclaimed by MAC provided that AIRLINE has maintained for each of the previous twelve consecutive months, and continues to maintain in its published schedule, an Average Daily Utilization at least equal to three departures on such Short Term Gate and AIRLINE has not been in default on any rental, security deposit, PFC or other payment obligation to MAC under this Agreement during the prior twelve consecutive months. For purposes of this provision "Average Daily Utilization" shall mean the number of AIRLINE's and any Affiliated Airline's scheduled aircraft departures using the gate with aircraft of fifty or more seats in a calendar month, divided by the number of days in that calendar month; provided, however, that if AIRLINE's or the Affiliated Airline's actual flight activity differs by more than five percent (5%) from its published schedule in any calendar month, MAC shall use AIRLINE's or the Affiliated Airline's actual total departures for purpose of calculating Average Daily Utilization.
6. If AIRLINE is leasing three (3) or fewer holdrooms from MAC, MAC agrees to not cancel the lease of more than one Short Term Gate AIRLINE may be leasing in accordance with the procedures identified in Section IV.H.2. as long as AIRLINE has adhered to the payment and utilization requirements identified within Section IV.H.5. for all leased gates for the previous twelve (12) consecutive months.
7. With respect to DELTA's Short Term Gates, MAC shall have the right to designate (a) Gate B14 as a Short Term Gate in which case Gate D5 shall no longer be designated a Short Term Gate and the terms and conditions of this Section IV.H. shall no longer apply to Gate D5 and/or (b) Gate B16 as a Short Term Gate, in which case Gates D1 shall no longer be designated a Short Term Gate and the terms and conditions of this Section IV.H. shall no longer apply to Gate D1.

#### **I. RELINQUISHMENT OF PREMISES**

##### **1. Notice of Intent to Relinquish Premises**

If AIRLINE desires to relinquish any of its Premises, AIRLINE shall provide written notice to MAC thirty (30) days in advance of such relinquishment and shall identify in such notice all areas it wishes to relinquish. MAC shall make its best efforts to lease such areas to another Airline, to the extent the proposed relinquished Premises is suitable for another Airline.

##### **2. Non-Waiver of Responsibility**

AIRLINE shall continue to be solely responsible pursuant to this Agreement for the payment of all rents, charges and fees related to the Premises until another Airline commences payment for said Premises as provided below.

3. Reduction of Rents, Fees, and Charges

AIRLINE's rents, fees and charges related to that portion of the Premises taken by another Airline, pursuant to such Airline's agreement with MAC, shall be reduced in the amount of the rent, fees and charges paid by such other Airline. This reduction shall begin only when the Airline that contracted with MAC for its use of the Premises begins payment for the Premises and shall end if such Airline becomes delinquent in payment for the Premises.

**J. OUTBOUND BAGGAGE AREAS**

MAC will provide an outbound baggage area that will include a Joint Use Space outbound baggage area for shared Airline use and a Preferential Use Space outbound baggage area for Airline use that is not shared.

**K. SURRENDER OF PREMISES**

1. Upon termination of this Agreement in its entirety, whether by its terms or by earlier cancellation, AIRLINE's rights to use the Premises, facilities, rights, licenses, services and privileges hereby given shall cease, and AIRLINE shall forthwith surrender possession to MAC.
2. All structures, fixtures, improvements, equipment and other property bought, installed, erected or placed by AIRLINE on the Premises or elsewhere on the Airport, including without limiting the generality thereof storage tanks, pipes, pumps, wires, poles, machinery and air conditioning equipment, shall be deemed to be personal property and remain the property of the AIRLINE, and AIRLINE shall have the right to remove the same if AIRLINE is not then in default; provided that, if AIRLINE elects to remove such property, AIRLINE shall remove its property within a period of ninety (90) days after termination, and shall restore the Premises to substantially the same condition as its condition as of the commencement of the Term hereof, ordinary wear and tear or damage by the elements, fire, explosion and other casualty excepted, but including any environmental restoration required of AIRLINE hereunder.
3. If AIRLINE's property is not so removed and the Premises restored prior to the expiration of the aforesaid period of ninety (90) days MAC shall thereafter have the right, by giving AIRLINE written notice thereof, to remove and store such property at AIRLINE'S cost, provided that MAC may immediately remove any property that is materially interfering with Airport operations after giving AIRLINE a reasonable opportunity to remove such property. If AIRLINE does not reimburse MAC for the costs of such removal and storage within an additional ninety (90) days thereafter, MAC may take title to such property and (a) take possession of such property, or (b) alternatively, cause such property to be sold or otherwise disposed of as MAC may elect, and AIRLINE hereby constitutes MAC its agent for the purpose of such removal and sale, and authorizes MAC in its sole discretion to determine the method of disposition. AIRLINE shall be responsible for any and all reasonable costs incurred by MAC in the removal of AIRLINE's property from the Premises and the disposition

4. thereof and for restoration of the Premises to substantially the same condition as existed prior to such removal, reasonable wear and tear and damage by casualty excepted. MAC shall pay over to AIRLINE any amount received from disposition of AIRLINE'S property in excess of the cost of removal, disposition, and restoration. Notwithstanding the foregoing, for any of AIRLINE'S aircraft, aircraft engines, and aircraft parts not so removed from the Premises within the aforesaid ninety (90) day period, MAC shall thereafter have the right, by giving AIRLINE prior written notice thereof, to cause such property to be removed and stored at AIRLINE'S cost and expense but MAC may not sell or take ownership of such property.
5. MAC reserves the right to make a reasonable rental charge covering the period following termination of the Agreement to the date of removal of AIRLINE'S property or until MAC gives AIRLINE notice of taking title thereto, or removal thereof, as set out above, provided that no charge shall be made for the first thirty (30) days following termination of the Agreement.

**L. TELECOMMUNICATIONS ROOMS AND FIBER/CABLING**

MAC may provide AIRLINE access to MAC telecommunication rooms, fiber-optic cable and associated infrastructure, depending on availability, pursuant to a separate license agreement. To the extent AIRLINE uses MAC telecommunication rooms, fiber-optic cable and associated infrastructure, AIRLINE agrees to do so according to the terms and conditions set forth in a MAC provided license agreement that is reasonably acceptable to AIRLINE, which shall be executed by MAC and AIRLINE. To the extent AIRLINE installs fiber/cabbling within the Airport, AIRLINE agrees to follow MAC'S Design and Construction Standards for such installation.

**M. MONTH TO MONTH PREMISES**

AIRLINE and MAC agree that the month-to-month premises shown on Exhibit T attached hereto are leased to AIRLINE on a month-to-month term; and that all of the terms and conditions of this Agreement, other than Article II, shall apply to such month-to-month premises.

**V. RENTS, FEES, AND CHARGES**

**A. GENERAL**

For use of the Premises, facilities, rights, licenses, services and privileges granted hereunder, AIRLINE agrees to pay MAC during the Term of this Agreement the rents, fees and charges as hereinafter described. Other than landing fees and the charges specified under Section V.B.8.a through h., all rents, fees and charges under Articles V and VI of this Agreement shall apply only to AIRLINE'S use of Terminal 1. AIRLINE'S use of Terminal 2 shall be governed by Ordinance 115, as the same has been or may be amended, or any other applicable ordinance.

**B. RENTS, FEES, AND CHARGES**

1. Landing Fees

AIRLINE shall pay to MAC monthly landing fees to be determined by multiplying the number of 1,000-pound units of AIRLINE's Total Landed Weight during the month by the then-current landing fee rate. The landing fee rate shall be calculated according to procedures set forth in Article VI.

2. Common Use Space Charges.

AIRLINE shall pay for its use of the Common Use Space, calculated according to procedures set forth in Article VI.

3. Terminal Apron Fees

AIRLINE shall pay to MAC monthly Terminal Apron fees to be determined by multiplying the number of lineal feet of Terminal Apron Preferential Use Space that is leased to AIRLINE (excluding Concourses A and B) during the month by the then-current Terminal Apron rate. AIRLINE shall pay to MAC monthly Terminal Apron fees associated with the Terminal Apron Preferential Use Space that is leased to AIRLINE for Concourses A and B to be determined by multiplying the number of lineal feet at the rate of fifty percent (50%) of the lineal feet associated with the Terminal Apron of Concourses A and B during the month by the then-current Terminal Apron rate. The Terminal Apron rate shall be calculated according to the procedures set forth in Article VI hereof.

4. Terminal 1 Building Rents and Surcharge

AIRLINE shall pay to MAC monthly Terminal 1 rentals and the Terminal 1 Repair and Replacement Surcharge for its Exclusive Use Space (janitored and unjanitored), Preferential Use Space and Joint Use Space in Terminal 1. The Terminal 1 rental rates shall be calculated according to the procedures set forth in Article VI.

Terminal 1 rentals and Terminal 1 Repair and Replacement Surcharge for Joint Use Space (except the IAF) shall be prorated among Signatory Airlines using the Joint Use Formula.

Terminal 1 rentals for Preferential Use Space and Exclusive Use Space shall be determined by multiplying the square feet of the applicable space times the then current Terminal 1 rental rate according to the procedures set forth in Article VI.

The Terminal 1 Repair and Replacement Surcharge for Preferential Use Space and Exclusive Use Space shall be determined by multiplying the applicable square feet of the space times the then current Terminal 1 Repair and Replacement Surcharge rate.

5. Carrousel and Conveyor Charges

AIRLINE shall pay to MAC monthly carrousel and conveyor charges based upon Operation and Maintenance Expenses and Debt Service. The carrousel and conveyor charges shall be calculated according to the procedures set forth in Article VI and shall be prorated among Signatory Airlines using the Joint Use Formula, provided however, that as long as DELTA operates and maintains the Inbound BHS and Outbound BHS, such costs incurred by DELTA will be charged to AIRLINE as specified in Sections VIII.C and VIII.D.

6. IAF Gate Fees

If AIRLINE does not lease the applicable IAF gate as Preferential Use Space, AIRLINE shall pay to MAC monthly IAF gate fees determined by multiplying the number of arrivals at the IAF by AIRLINE's propeller aircraft, narrow-body jet aircraft, and wide-body jet aircraft by \$400, \$800, and \$1,200, respectively. MAC may reasonably increase these rates at any time with 60 days' advance written notice to AIRLINE.

7. IAF Use Fees

AIRLINE shall pay to MAC monthly IAF use fees determined by multiplying the number of AIRLINE's international passengers arriving at the IAF during the month by the IAF use fee rate. The IAF use fee rate shall be calculated according to procedures set forth in Article VI.

8. Other Fees and Charges

AIRLINE shall pay to MAC reasonable fees for the various other services provided by MAC to AIRLINE. These services include, but may not be limited to, the following:

- a. Use of Terminal 2 and the Terminal 2 ramp at rates established from time to time by MAC.
- b. Use of valet parking for AIRLINE's employees at rates set forth in MAC Policies.
- c. Use of designated employee parking facilities by AIRLINE's employees at rates established from time to time by MAC.
- d. Non-routine Terminal Apron cleaning and other special services requested by AIRLINE at rates that reflect the costs incurred by MAC.
- e. Security and personnel identification badges for AIRLINE's personnel at rates established from time to time by MAC.
- f. Charges for the cost of separately metered water and sewer and other such utilities not otherwise included in the calculation of rents, fees, and charges.

- g. Other charges as described in Section VI.M.
- h. Other charges as described in Section VI.K.

**C. MONTHLY ACTIVITY REPORT**

1. Contents and Due Date

Without any demand therefor AIRLINE shall furnish MAC on or before the 10th day of each and every month, the IAF reports and an accurate written report of AIRLINE's operations during the preceding month, setting forth all data necessary to calculate the AIRLINE's fees and charges due under this Agreement. Said report shall be in a format prescribed by MAC and shall include the following: (a) AIRLINE's actual aircraft revenue flight arrivals at the Airport by type of aircraft, Maximum Certificated Gross Landing Weight of each type of aircraft, and Total Landed Weight; (b) the total number of Enplaned Passengers, Deplaned Passengers, and Non-Revenue Passengers and Through Passengers of AIRLINE at the Airport, breaking Enplaned Passengers into originating and connecting passengers; (c) the amount of domestic and international cargo, mail, and express packages (in pounds) enplaned and deplaned by AIRLINE at the Airport; (d) the total number of scheduled and nonscheduled aircraft operations at the Airport; and (e) a summary reflecting all of AIRLINE's actual flight activity by aircraft type for gates, and the IAF. MAC may require AIRLINE to submit such reports through a portal or other database prescribed by MAC.

AIRLINE shall also provide to MAC a separate report for each Affiliated Airline. AIRLINE shall provide to MAC additional reports MAC may reasonably request.

2. Failure to Report

If AIRLINE fails to furnish MAC with the monthly activity report by the due date, AIRLINE's landing fees, IAF gate fees, and IAF use fees, as provided for hereinafter, shall be determined by assuming that AIRLINE's activity factor, as appropriate for each fee, for such month was one hundred percent (100 percent) of its activity factor, as appropriate for each fee, during the most recent month for which such data are available for AIRLINE. Any necessary adjustment in such fees shall be calculated after an accurate report is delivered to MAC by AIRLINE for the month in question. Resulting surpluses or deficits shall be applied as credits or charges to the appropriate invoices in the next succeeding month.

3. Inspection and Maintenance of Records

AIRLINE shall maintain records, accounts, books and data with respect to its operations at the Airport sufficient to permit MAC to calculate and verify the rents, fees and charges due under this Agreement, which shall cover a period of not less than three (3) years beyond the end of AIRLINE's fiscal year in which such record was created. Such records shall be subject to inspection and audit by MAC at all reasonable times.

**D. SECURITY DEPOSITS**

1. Unless AIRLINE has provided regularly scheduled passenger, all cargo or combination flights to and from the Airport for the twelve (12) months immediately prior to AIRLINE's execution of this Agreement (or immediately prior to the assignment of this Agreement to AIRLINE) without an act or omission having occurred that would have been an event of default under Article XIV of this Agreement if this Agreement had been in effect during this period, AIRLINE shall provide MAC upon the execution of this Agreement (or upon the assignment of this Agreement to AIRLINE) with a contract bond, irrevocable letter of credit or other security acceptable to MAC ("Contract Security") in an amount equal to the total of three (3) months' estimated rents, fees and charges payable by AIRLINE under Article V of this Agreement plus three (3) months' estimated PFC collections under this Article V, to guarantee the faithful performance by AIRLINE of all of its obligations under this Agreement and the payment of all rents, fees, and charges due hereunder and of all PFCs due to MAC. Such Contract Security shall be in such form and with such company licensed to do business in the State of Minnesota as shall be acceptable to MAC within its reasonable discretion.
2. AIRLINE shall be obligated to maintain Contract Security in an amount equal to MAC's estimate of three months' rents, fees, and charges plus three (3) months' estimated PFC collections payable hereunder and to maintain this Contract Security in effect until the expiration of twelve (12) consecutive months (including any period prior to AIRLINE's execution of this Agreement during which AIRLINE provided regularly scheduled flights to and from the Airport) during which no event of default under Article XIV of this Agreement (and for any such prior period, no act or omission that would have been such an event of default hereunder) has occurred. If such Contract Security should be canceled, AIRLINE shall provide a renewal or replacement Contract Security for the period required pursuant to this Section. AIRLINE shall provide at least sixty (60) days prior written notice of the date on which any Contract Security expires or is subject to cancellation.
3. If an event of default, beyond any applicable notice and cure period, under Section XIV. A. 1, 2, or 5 of this Agreement shall occur, MAC shall have the right, by written notice to AIRLINE given at any time within ninety (90) days of such event of default, to impose or reimpose the requirements of this Section on AIRLINE. In such event, AIRLINE shall within ten (10) days from its receipt of such written notice provide MAC with the required Contract Security and shall thereafter maintain such Contract Security in effect until the expiration of the required period during which no event of default under Article XIV of this Agreement occurs. MAC shall have the right to reimpose the requirements of this Section on AIRLINE each time an event of default occurs during the Term of this Agreement. MAC's rights under this Section shall be in addition to all other rights and remedies provided it under this Agreement.
4. To the extent that AIRLINE holds any property interest in PFC funds collected for the benefit of MAC, AIRLINE hereby pledges to MAC and grants MAC a first priority security interest in such funds, and in any and all accounts into which such funds are deposited.



5. Affiliated Airlines are excluded from the Contract Security requirement in this Section V.D.

**E. PAYMENT PROVISIONS**

1. Terminal rentals for Exclusive Use Space and Preferential Use Space, fees per the Joint Use Formula, and Terminal Apron Fees shall be due and payable the first day of each month in advance without invoice from MAC.
2. Within ten (10) days following the last day of each month, AIRLINE shall transmit to MAC payment for the amount of landing fees, IAF gate fees, and IAF use fees incurred by AIRLINE during said month, as computed by AIRLINE without invoice from MAC.
3. For Common Use Space charges, AIRLINE shall transmit to MAC payment within ten (10) days following receipt of an invoice from MAC, for the charges incurred by AIRLINE during the previous month.
4. All other rents, fees, or charges set forth herein, including supplemental billings for year-end adjustments, if any, shall be due within thirty (30) days of the date of the invoice therefor.
5. The acceptance by MAC of any payment made by AIRLINE shall not preclude MAC from verifying the accuracy of AIRLINE's report and computations or from recovering any additional payment actually due from AIRLINE.
6. Any payment not received within thirty (30) days of the due date shall accrue interest at the rate of 1.5 percent per month measured from the due date until paid in full.
7. Payments shall be made to the order of the "Metropolitan Airports Commission." AIRLINE agrees to use electronic transfer of funds as the method of payment.
8. Any non-electronic payments shall be sent to the following address or such other place as may be designated by MAC from time to time:

Metropolitan Airports Commission  
NW-9227 PO Box 1450  
Minneapolis, MN 55485

**F. NET AGREEMENT**

This is a net agreement with reference to rents, fees, and charges paid to MAC. AIRLINE shall pay all taxes, fees, or assessments of whatever character that may be lawfully levied, assessed, or charged by any governmental entity upon the property, real and personal, occupied, used, or owned by AIRLINE, or upon the rights of AIRLINE to

occupy and use the Premises, or upon AIRLINE's improvements, fixtures, equipment, or other property thereon, or upon AIRLINE's rights or operations hereunder. AIRLINE shall have the right at its sole cost and expense to contest the amount or validity of any tax or license as may have been or may be levied, assessed, or charged.

**G. NO OTHER FEES AND CHARGES**

Except as expressly provided for this Agreement, no further rents, fees, or similar charges shall be charged against or collected from AIRLINE by MAC for the Premises, facilities, rights and licenses expressly granted to AIRLINE in this Agreement. Further, except as expressly provided for in this Agreement, including but not limited to Section III.B.3., or MAC Rules and Regulations and Ordinances, no further rents, fees, or similar charges shall be charged against or collected from AIRLINE's shippers, and receivers of freight and express packages and its suppliers of goods and services, by MAC for the Premises, facilities, rights and licenses granted to AIRLINE in this Agreement.

**H. PASSENGER FACILITY CHARGES**

MAC expressly reserves the right to assess and collect PFCs in accordance with the PFC Regulations. The following shall apply to the collection of PFCs:

1. AIRLINE shall hold the net principal amount of all PFCs that are collected by AIRLINE or its agents on behalf of MAC in trust for MAC as and to the extent required by the PFC Regulations. For purposes of this Section, net principal amount shall mean the total principal amount of all PFCs that are collected by AIRLINE or its agents on behalf of MAC, reduced by all amounts that AIRLINE is permitted to retain pursuant to the PFC Regulations.
2. In the absence of additional regulations governing the treatment of refunds, any refunds of PFCs due to passengers as a result of changes of itinerary shall be paid proportionately out of the net principal amount attributable to such PFCs and the amount that AIRLINE was permitted to retain under the PFC Regulations attributable to such PFCs. AIRLINE hereby acknowledges that the net principal amount of all PFCs collected on behalf of MAC shall remain at all times the property of MAC, except to the extent of amounts refunded to passengers pursuant to the preceding sentence (which shall remain the property of MAC until refunded and become the property of the passenger upon and after refund) or are otherwise not considered property of the airport operator under the PFC Regulations. Other than the amounts that AIRLINE is entitled to retain pursuant to the PFC Regulations, AIRLINE shall be entitled to no compensation.
3. In the event AIRLINE fails to remit PFC revenues to MAC within the time limits required by the PFC Regulations, such event shall be an event of default subject to Article XIV of this Agreement.

**I. NON-WAIVER**

The acceptance of fees by MAC for any period or periods after a default of any of the terms, covenants and conditions herein contained to be performed, kept and observed by AIRLINE, shall not be deemed a waiver of any right on the part of MAC to terminate this MSP Airline Agreement 1-1-19 VI. Calculations of Rents, Fees, and Charges Agreement for failure by AIRLINE to perform, keep or observe any of the terms, covenants or conditions of this Agreement.

**J. NON-SIGNATORY LANDING FEES**

The landing fee rate charged to any Airline that is not a Signatory Airline shall be in accordance with the rates established by ordinance from time to time by MAC.

**K. AFFILIATED AIRLINES**

Affiliated Airlines (including AIRLINE if it is an Affiliated Airline) shall not count for the purpose of apportioning the fixed (i.e. 20%) portion of the Joint Use Formula, but their Enplaned Passengers shall be included in assessing and apportioning the variable (i.e. 80%) portion of the Joint Use Formula to the Airline for which they are an Affiliate while flying as an Affiliate of such Airline at the Airport. If AIRLINE has designated an Airline as an Affiliated Airline, AIRLINE hereby unconditionally guarantees all rents, fees and charges including passenger facility charges of any Affiliated Airline so designated by AIRLINE while it is flying on behalf of AIRLINE at the Airport, and upon receipt of notice of payment default by such Affiliated Airline (with a copy to AIRLINE), AIRLINE will pay such amounts to MAC on demand pursuant to the payment provisions of this Agreement. AIRLINE must give MAC thirty (30) days advance written notice in order to designate an Airline as an Affiliated Airline or to revoke such status.

**L. ALLIANCE PARTNERS**

Alliance Partners shall not count for the purpose of apportioning the fixed (i.e. 20%) portion of the Joint Use Formula, but their Enplaned Passengers shall be included in assessing and apportioning their share of the variable (i.e. 80%) portion.

**VI. CALCULATION OF RENTS, FEES, AND CHARGES**

**A. GENERAL**

Each Fiscal Year, rents, fees, and charges will be reviewed and recalculated based on the principles and procedures set forth in this Article VI. The annual costs associated with each of the indirect cost centers shall be allocated to each of the applicable Airport Cost Centers based on the allocations as set forth in Exhibit M, Indirect Cost Center Allocation, which allocations may be reasonably adjusted from time to time by MAC and approved by a Majority-In-Interest of Signatory Airlines. Such approval may not be unreasonably withheld. Such allocation adjustment shall be deemed approved by a Majority-In-Interest of Signatory Airlines unless MAC receives, within forty-five (45) days after emailing or mailing such allocation adjustment: (a) written responses from a Majority-In-Interest of Signatory Airlines and such responses signify that a Majority-In-Interest of Signatory Airlines disapprove of such allocation adjustment or (b) a certificate from the chair of the MSP Airport Affairs Committee stating such disapproval, with supporting documentation establishing that a Majority-In-Interest of Signatory Airlines disapprove of such allocation adjustment.

**B. CALCULATION/COORDINATION PROCEDURES**

1. AIRLINE shall provide to MAC: (a) on or before August 1 of each year a preliminary estimate of Total Landed Weight and Enplaned Passengers for the succeeding calendar year of AIRLINE and each Affiliated Airline, unless separately reported to MAC by such Affiliated Airline; and (b) on or before October 1 of each year a final estimate of such weight. If the final estimate is not so received, MAC may continue to rely on the preliminary estimate for the MAC budgeting process. MAC will utilize the forecast in developing its preliminary calculation of Total Landed Weight and Enplaned Passengers for use in the calculation of rents, fees, and charges for the ensuing Fiscal Year.
2. On or before October 15 of each Fiscal Year, MAC shall submit to AIRLINE a preliminary calculation of rents, fees, and charges for the ensuing Fiscal Year. The preliminary calculation of rents, fees, and charges will include, among others, MAC's estimate of all revenue items, Operation and Maintenance Expenses, Debt Service, Capital Outlays, required deposits, including amounts necessary to be deposited in the Coverage Account in order to meet MAC's rate covenant under the Trust Indenture, and Rentable Space.
3. Within fifteen (15) days after receipt of the preliminary calculation of rents, fees, and charges, if requested by the Signatory Airlines, MAC shall schedule a meeting between MAC and the Signatory Airlines to review and discuss the proposed rents, fees, and charges.
4. MAC shall then complete a calculation of rents, fees, and charges at such time as the budget is approved, taking into consideration the comments or suggestions of AIRLINE and the other Signatory Airlines.
5. If, for any reason, MAC's annual budget has not been adopted by the first day of any Fiscal Year, the rents, fees, and charges for the Fiscal Year will initially be established based on the preliminary calculation of rents, fees, and charges until such time as the annual budget has been adopted by MAC. At such time as the annual budget has been adopted by MAC, the rents, fees, and charges will be recalculated, if necessary, to reflect the adopted annual budget and made retroactive to the first day of the Fiscal Year and any difference shall be charged, credited, or refunded to AIRLINE and paid or credited by AIRLINE or MAC, as applicable, within thirty (30) days thereafter.
6. If, during the course of the year, MAC believes significant variances exist in budgeted or estimated amounts that were used to calculate rents, fees, and charges for the then current Fiscal Year, MAC may after notice to Airlines adjust the rents, fees, and charges to reflect current estimated amounts.

**C. LANDING FEES**

MAC shall calculate the landing fee rate in the following manner and as illustrated in Exhibit N.

1. The total estimated "Airfield Cost" shall be calculated by totaling the following annual amounts:
  - a. The total estimated direct and allocated indirect Operation and Maintenance Expenses allocable to the Airfield cost center.
  - b. The estimated direct and allocated indirect Debt Service net of amounts paid from PFCs or grants allocable to the Airfield cost center.
  - c. The cost of Runway 17/35 deferred and not yet charged will be charged through December 31, 2035 at \$79,535.16 annually.
  - d. The Landing Fee Repair and Replacement Amount.
  - e. The amount of any fine, assessment, judgment, settlement, or extraordinary charge (net of insurance proceeds) paid by MAC in connection with the operations on the Airfield, to the extent not otherwise covered by Article X hereof.
  - f. The amounts required to be deposited to funds and accounts pursuant to the terms of the Trust Indentures, including, but not limited to, its Debt Service reserve funds directly or indirectly allocable to the Airfield cost center. MAC agrees to exclude from the calculation of landing fees the amounts which it may deposit from time to time to the maintenance and operation reserve account and the Coverage Account established and maintained pursuant to the Senior Trust Indenture except for such amounts which are necessary to be deposited to the Coverage Account in order for MAC to meet its rate covenants under the Trust Indentures.
2. The total estimated Airfield Cost shall be adjusted by the total estimated annual amounts of the following items to determine the "Net Airfield Cost":
  - a. Service fees received from the military, to the extent such fees relate to the use of the Airfield;
  - b. General aviation and non-signatory landing fees;
  - c. Debt Service on the Capital Cost, if any, disapproved by a Majority-In-Interest of Signatory Airlines.
3. The Net Airfield Cost shall then be divided by the estimated Total Landed Weight (expressed in thousands of pounds) of the Signatory Airlines operating at the Airport to determine the landing fee rate per 1,000 pounds of aircraft weight for a given Fiscal Year.

**D. TERMINAL APRON FEES**

MAC shall calculate the Terminal Apron rate in the following manner and as illustrated in Exhibit N.

1. The total estimated "Terminal Apron Cost" shall be calculated by totaling the following annual amounts:
  - a. The total estimated direct and allocated indirect Operation and Maintenance Expenses allocable to the Terminal Apron cost center.
  - b. The estimated direct and allocated indirect Debt Service net of amounts paid from PFCs or grants allocable to the Terminal Apron cost center (excluding hydrant fueling repairs and modifications).
  - c. The cost of Concourse A and B Apron Area deferred and not yet charged will be charged through December 31, 2035 at \$159,950.19 annually.
  - d. The amounts required to be deposited to funds and accounts pursuant to the terms of the Trust Indentures, including, but not limited to, its Debt Service reserve funds directly or indirectly allocable to the Terminal Apron cost center. MAC agrees to exclude from the calculation of Terminal Apron fees the amounts which it may deposit from time to time to the maintenance and operation reserve account and the Coverage Account established and maintained pursuant to the Senior Trust Indenture except for such amounts which are necessary to be deposited to the Coverage Account in order for MAC to meet its rate covenants under the Trust Indentures.
  - e. The Terminal Apron Repair and Replacement Amount.
2. The Terminal Apron Cost shall then be divided by the total estimated lineal feet of Terminal Apron, to determine the Terminal Apron rate per lineal foot for a given Fiscal Year. For the purposes of this calculation, lineal feet of Terminal Apron shall be computed as the sum of the following:
  - a. Lineal feet of the Terminal Apron (excluding the Terminal Apron associated with Concourses A & B); and
  - b. Fifty percent (50%) of lineal feet of the Terminal Apron associated with Concourse A & B.

**E. TERMINAL 1 BUILDING RENTS**

MAC shall calculate the Terminal 1 building rental rate for unjanitored and janitored space in the Terminal 1 building as set forth in subsections 1 and 2 of this Section VI.E.

1. MAC shall calculate the Terminal 1 building rental rate for unjanitored space in the Terminal 1 building in the following manner and as illustrated in Exhibit N.
  - a. The total estimated Terminal Building Cost shall be calculated by totaling the following annual amounts:
    - 1) The total estimated direct and allocated indirect Operation and Maintenance Expenses allocable to the Terminal Building cost center.
    - 2) The estimated direct and allocated indirect Debt Service net of amounts paid from PFCs or grants allocable to the Terminal Building cost center.
    - 3) The cost of Concourse A, B, C and D deferred and not yet charged will be charged through December 31, 2035 at \$2,910,547.40 annually.
    - 4) The amounts required to be deposited to funds and accounts pursuant to the terms of the Trust Indentures, including, but not limited to, its Debt Service reserve funds directly or indirectly allocable to the Terminal 1 cost center. MAC agrees to exclude from the calculation of Terminal Rents the amounts which it may deposit from time to time to the maintenance and operation reserve account and the Coverage Account established and maintained pursuant to the Senior Trust Indenture except for such amounts which are necessary to be deposited to the Coverage Account in order for MAC to meet its rate covenants under the Trust Indentures.
  - b. The total estimated Terminal Building Cost shall be reduced by the total estimated annual amounts of the following items to determine the "Net Terminal Building Cost":
    - 1) Reimbursed expense:
      - a) IAF Operation and Maintenance Expenses;
      - b) Carrousel and conveyor Debt Service and Operation and Maintenance Expense;
      - c) Ground power;
      - d) Loading dock;
      - e) Concession utilities, and
      - f) Items described in Section VI.K. and VI.M. to the extent directly reimbursed.

- 2) Janitorial Operation and Maintenance Expenses incurred by MAC.
- c. The Net Terminal Building Cost shall then be divided by the total estimated Rentable Space in the Terminal 1 building to determine the Terminal 1 building rental rate per square foot for unjanitored space for a given Fiscal Year. (See Initial Rentable Square Footage, Exhibit O).
2. MAC shall calculate the Terminal 1 building rental rate for janitored space by totaling the following rates and as illustrated in Exhibit N:
  - a. The Terminal 1 building rental rate per square foot for unjanitored space for a given Fiscal Year, as calculated in this Section; and
  - b. An additional rate per square foot, the janitored rate, calculated by dividing the total estimated direct Janitorial Operation and Maintenance Expenses, as determined by MAC, by the total janitored space in the Terminal 1 building (excluding MAC and mechanical space).

**F. CARROUSEL AND CONVEYOR CHARGE**

1. MAC shall calculate the carrousel and conveyor charge by totaling the following annual amounts: equipment charges associated with the carrousel and conveyor (if any), including annual Debt Service; Operation and Maintenance Expense; and service charge (if any).
2. MAC shall prorate the carrousel and conveyor charge among the Signatory Airlines using the Joint Use Formula.
3. Notwithstanding anything herein to the contrary, so long as DELTA operates and maintains the Inbound BHS and Outbound BHS, such costs incurred by DELTA will be charged to AIRLINE as specified in Sections VIII.C and VIII.D.

**G. IAF USE FEES**

The IAF use fee for use of the IAF shall be based upon:

1. The cost of the maintenance and operation of the International Arrivals Facility which may include, but is not limited to:
  - a. utilities;
  - b. cleaning;
  - c. maintenance (including the costs of maintaining the security equipment that existed as of April 1998);
  - d. police, fire, and administrative cost allocation;
  - e. costs of providing passenger baggage carts, if any;



- f. costs of providing staff parking for federal inspections agency staff; and
  - g. \$35,064 per month for recoupment for lost rental area in the G Concourse.
2. Costs associated with the operation of dual international arrivals facility locations at the Airport, based on the appropriate allocation of costs between the two facilities, not otherwise funded by the federal inspections agencies including, but not limited to additional personnel and equipment used by those agencies; and
  3. Estimated direct and allocated indirect Debt Service, if any.

Each Fiscal Year, the IAF use fee shall be calculated by first summing the budgeted costs for items (1) through (3) above and then dividing by total estimated passengers arriving at the IAF. AIRLINE shall be billed for IAF use fees monthly, and such use fees shall be set annually at an estimated charge through MAC's budget process and then adjusted at year end for actual costs and actual passengers arriving at the IAF pursuant to certified audit by MAC's external auditors and such difference shall be charged, refunded, or credited to AIRLINE and paid or credited by AIRLINE or MAC within thirty (30) days thereafter.

On a monthly basis for compensation for use of gates G1-G10 for scheduled international aircraft arrivals, so long as the applicable gates are leased by DELTA, MAC shall pay DELTA, \$400, \$800 and \$1,200, for each arrival by, respectively, propeller aircraft, narrow-body jet aircraft or wide-body aircraft at the IAF. MAC may reasonably increase these rates at any time with 60 day advance written notice to DELTA.

#### **H. YEAR-END ADJUSTMENTS OF RENTS, FEES, AND CHARGES**

1. As soon as practical following the close of each Fiscal Year, but in no event later than July 1, MAC shall furnish AIRLINE with an accounting of the costs actually incurred and revenues and credits actually realized during such Fiscal Year with respect to each of the components of the calculation of the rents, fees, and charges calculated pursuant to this Article broken down by rate making Airport Cost Center.
2. In the event AIRLINE's rents, fees, and charges billed during the Fiscal Year exceed the amount of AIRLINE's rents, fees, and charges required (as recalculated based on actual costs and revenues), such excess shall be refunded or credited to AIRLINE.
3. In the event AIRLINE's rents, fees, and charges billed during the Fiscal Year are less than the amount of AIRLINE's rents, fees, and charges required (as recalculated based on actual costs and revenues), such deficiency shall be charged to AIRLINE in a supplemental billing.
4. This section does not apply to Common Use Space charges. This provision shall survive an expiration or termination of this Agreement.

**I. REVENUE SHARING**

1. Subject to Section VI.J, in conjunction with its year-end adjustments of rents, fees and charges, MAC will rebate to AIRLINE a percentage of the Annual Gross Revenues for Selected Concessions for the most recent Fiscal Year under the following schedule (“Revenue Sharing”).
  - a. For Fiscal Years 2019 and 2020, if the Enplaned Passenger Growth Percentage for the most recent Fiscal Year is one percent or less, the Revenue Sharing percentage for that Fiscal Year shall be 31.00%. For Fiscal Years after 2020, if the Enplaned Passenger Growth Percentage for the most recent Fiscal Year is one percent or less, the Revenue Sharing percentage for that Fiscal Year shall be 33.00%.
  - b. For Fiscal Years 2019 and 2020, if the Enplaned Passenger Growth Percentage for the most recent Fiscal Year is more than one percent, the Revenue Sharing percentage for that Fiscal Year shall be the sum of (i) 31.00% and (ii) one-half of the Enplaned Passenger Growth Percentage. For Fiscal Years after 2020, if the Enplaned Passenger Growth Percentage for the most recent Fiscal Year is more than one percent, the Revenue Sharing percentage for that Fiscal Year shall be the sum of (i) 33.00% and (ii) one-half of the Enplaned Passenger Growth Percentage.
2. The total Revenue Sharing rebate shall be allocated among the Signatory Airlines according to their pro rata share of Enplaned Passengers for the most recent Fiscal Year and shall be structured as a post-year-end rebate to AIRLINE issued by MAC no later than 240 days following each Fiscal Year, subject to correction following any applicable audit. If AIRLINE is in default, as specified in Section XIV.A., beyond any applicable notice and cure period, MAC shall have the right, (a) for monetary defaults, to set off against any Revenue Sharing rebate otherwise due AIRLINE under this Section the amounts, if any, then due and owing by AIRLINE to MAC under this Agreement, and (b) for non-monetary defaults for which damages can be reasonably estimated in MAC’s reasonable discretion, to withhold from the Revenue Sharing otherwise due AIRLINE under this Section such amount that is reasonably necessary to cure the default and/or remedy the damage to MAC plus an additional 25 percent (25%) so long as such default remains uncured. Any amounts withheld may be withheld by MAC until the applicable default is cured; at which such time MAC shall rebate any amount withheld to AIRLINE, less any amounts actually incurred by MAC to cure such default and any amounts necessary to remedy financially calculable harm to MAC that actually occurred due to such default. Any offset or reduction in the total rebate payable to any Airline made pursuant to (a) above shall be retained by MAC. Any offset or reduction in the total rebate payable to any Airline made pursuant to (b) above (but not amounts merely withheld) shall be retained by MAC, less any amount rebated to AIRLINE. An Affiliated Airline of AIRLINE shall not be entitled to Revenue Sharing, however its Enplaned Passengers shall be included in the calculation of AIRLINE’s share of Revenue Sharing. An EAS Airline shall not be entitled to Revenue Sharing.

3. Notwithstanding the foregoing, MAC shall have the right to reduce the amount of Revenue Sharing with respect to any Fiscal Year to the extent necessary so that the Net Revenues of the MAC taking into account the Revenue Sharing for such Fiscal Year will not be less than 1.25x of the total Debt Service of MAC for such Fiscal Year. In the event that the Revenue Sharing is reduced in any Fiscal Year by any amount (the "Deferred Revenue Sharing Amount") as a result of the operation of this Article VI, MAC will accrue the Deferred Revenue Sharing Amount and credit such amount to the Signatory Airlines in the subsequent Fiscal Year (or, if such amount may not be credited in accordance with this Article VI in such subsequent Fiscal Year, then such amount will be credited in the next succeeding Fiscal Year in which such credit may be issued in accordance with this Article VI).

**J. REVERSION TO ALTERNATE RATE STRUCTURE**

1. Notwithstanding anything in the Lease or any other agreement between MAC and AIRLINE, in the event AIRLINE is not in compliance with any payment obligation under any agreement with the MAC during the period following any applicable notice and cure period herein or therein and continuing until payment of any such amounts (the "Payment Default Period"), MAC will have the right, upon written notice to AIRLINE (provided that, if AIRLINE is in bankruptcy, no notice shall be required for the effectiveness of MAC's exercise of such right, in each case so long as AIRLINE is invoiced by MAC for the amounts payable pursuant to the Alternate Rate Structure instead of Section V.B and Article VI and all such invoices reference the additional amounts due as a result of such payment default and set forth the applicable rates that are then in effect as a result of such payment default), to: (i) have AIRLINE's payment obligations under the Lease during the Payment Default Period be governed by the Alternate Rate Structure instead of the rate structure set forth in Section V.B and Article VI, and (ii) apply the amount of any Rate Differential for AIRLINE during such period and the amount of any accrued and unpaid Revenue Sharing credits (if any) otherwise due to AIRLINE pursuant to Article VI for the Payment Default Period against any amounts owed by AIRLINE to MAC to the extent necessary to cure such payment defaults.

**K. AIRLINE SERVICES PROVIDED BY MAC IN TERMINAL 1**

1. Scope and Costs

In accordance with the terms of this Section VI.K, AIRLINE agrees to reimburse MAC for providing the services described in this Section that generally benefit the Signatory Airlines using Terminal 1 or that primarily benefit AIRLINE. Except as and to the extent set forth in Section VI.K.4. below, MAC is under no obligation to provide any of these airline services. However, if MAC agrees to provide the services it shall charge AIRLINE as specified in this Section VI.K.

2. Existing Services

For existing services historically provided by Airlines, the costs of providing such services will be recovered by MAC as follows: (a) if the services generally benefit the Airlines utilizing Terminal 1, the costs will be assessed using the Joint Use Formula; or (b) if the services primarily benefit a limited number of Airlines utilizing Terminal 1, MAC will directly bill those Airlines benefiting from the services their pro rata share based on Enplaned Passengers.

These airline services include but are not limited to porter services, security line management services, and technology related services such as flight information displays, ticket counter back wall monitors, and content management systems (but exclude future services, Employee Screening services, and services addressed elsewhere in this Agreement), the costs of which are not otherwise included in and recovered through the other rents, fees and charges assessed under this Article VI. Additionally, these airline services shall also include security costs for law enforcement officers within the ticketing or baggage claim or concourse areas of Terminal 1 to the extent these law enforcement officers are specifically requested by one or more Signatory Airlines and are in addition to the law enforcement officers MAC typically provides.

3. Future Services

For future related airline services provided by MAC, AIRLINE shall reimburse MAC for the costs of such services in the manner described in Section VI.K.2, unless such costs are disapproved by a Majority-In-Interest of the Terminal 1 Signatory Airlines in accordance with the procedures in Section VII.B.1. Majority-In-Interest review shall not be required any services that primarily benefit a limited number of Airlines if those Airlines agree to pay for and be directly billed for those services.

4. Terminal 1 Airline Employee Screening

Effective January 1, 2019, MAC shall begin performing (through a 3rd party contractor) the screening of AIRLINE's and its contractors' and subcontractors' employees who enter secure areas from within Terminal 1 ("Employee Screening."). This does not include AIRLINE employees entering secure, SIDA, or AOA areas from outside Terminal 1 such as the Airfield gates or other buildings at the Airport. The indemnification obligations of AIRLINE set forth in Section X.A. shall apply to this Section. MAC shall have sole and absolute discretion establishing Employee Screening locations and, subject to fulfilling its obligations in this Section, MAC makes no guarantee that existing AIRLINE or MAC screening locations will continue to be operated or available for screening functions; provided, however, that such locations shall be sufficient to perform the Employee Screening in a timely manner. Should MAC elect not to provide Employee Screening at an existing AIRLINE operated Employee Screening location, AIRLINE may continue to provide Employee Screening for its own

employees and contractors at its own cost and expense at such location, provided that MAC may require such location to be closed at any time, in MAC's sole discretion, and AIRLINE may elect to close such location at any time. Employee Screening will be performed at locations that screen employees of other tenants, contractors, and subcontractors at the Airport and/or MAC's and its contractors' and subcontractors' employees. At any time, MAC may elect to transfer responsibility for Employee Screening to the Transportation Security Administration (or successor agency) if and to the extent the Transportation Security Administration (or successor agency) is willing to assume such responsibility, and AIRLINE shall reasonably cooperate with MAC to facilitate such move. Any expense MAC incurs for Employee Screening attributed to Signatory Airlines will be prorated among the Signatory Airlines using the Joint Use Formula and AIRLINE's proportionate share shall be billed to AIRLINE directly. MAC may, upon 365 days' advance notice to AIRLINE, stop performing Employee Screening.

**L. TERMINAL 1 COMMON USE SPACE CHARGES**

Use of and charges for Common Use Space in Terminal 1 shall be governed under a Memorandum of Understanding between MAC and any Airline that desires to use such Common Use Space at Terminal 1. AIRLINE agrees that such Memorandum of Understanding will be superseded and no longer in effect if a MAC Ordinance and/or Rules or Regulations are adopted that governs use of and charges for Common Use Space at Terminal 1.

**M. MAC-OWNED SYSTEMS AND EQUIPMENT AND UTILITIES INSURANCE COSTS**

MAC may seek to procure certain insurance policies, additional coverages and/or additional limits for the benefit of MAC and/or Airlines that insure against losses incurred by MAC and/or Airlines related to the failure or outage of MAC-Owned Systems and Equipment and/or the failure or outage of utilities or services described in Section VIII.A.4 (such as power, water, gas, fiber, HVAC, etc.). In connection with such procurement, upon AIRLINE's timely request, AIRLINE shall have the opportunity to participate in the procurement and review of any such insurance policies (including the continuation of policies not yet in place as of the effective date of this Agreement if premiums will increase by more than 10%), and MAC shall consider, in good faith, AIRLINE's comments, position, and concerns regarding such procurement. If any such policies are procured, AIRLINE shall reimburse MAC for premiums and other related costs of such insurance policies in the manner described below, unless such insurance policies are disapproved by a Majority-In-Interest of Signatory Airlines in accordance with the procedures in Section VII.B.1 and as modified below, in which case MAC may still elect to procure such insurance policies, but may not charge such insurance premium costs directly to Airlines, but such insurance premium costs will be reasonably allocated by MAC to all Airport Cost Centers that benefit from such insurance policies. Eighty percent (80%) of the premium costs for such insurance policies that are not disapproved by a Majority-In-Interest of Signatory Airlines (except that, for purposes of disapproval under this section, the MII rules will be altered by replacing references to a majority of all Signatory Airlines with reference to a majority of all Signatory Airlines responding to the notice) shall be allocated on a reasonable basis by MAC to Terminal 1 and Terminal

2, and twenty percent (20%) of such premium costs shall be reasonably allocated to other Airport Cost Center(s) that benefit from such insurance policies. Such insurance premium costs allocated to Terminal 1 will be charged to Terminal 1 Signatory Airlines using the Joint Use Formula. Such allocated insurance premium costs allocated to Terminal 2 will be included in Terminal 2 rates and charges prescribed by MAC Ordinance. Notwithstanding anything herein to the contrary, any insurance policies procured under this Section VI.M. shall be primary with respect to any damages covered thereby and respond prior to any insurance AIRLINE is required to maintain hereunder, provided that where more than one party is at fault each party's insurance shall be primary with respect to that party's portion of the liability.

## VII. CAPITAL EXPENDITURES

### A. GENERAL

1. Subject to the provisions of Sections B and D of this Article, MAC may incur costs to plan, design, and construct Capital Projects to preserve, protect, enhance, expand, or otherwise improve the Airport System, or parts thereof, at such time or times as it deems appropriate, and may recover through airline rents, fees, and charges the costs of such Capital Projects.
2. MAC will use its best efforts to obtain and maximize federal and state grants, including MNDOT and AIP grants.
3. Subject to the provisions of this Article, MAC may pay the Capital Cost associated with any Capital Project using funds lawfully available for such purposes as it deems appropriate, and may issue Airport Bonds and Other Forms of Indebtedness in amounts sufficient to finance any Capital Project.
4. Nothing in this Agreement, including this Article VII, shall be interpreted: (a) to impair the authority of MAC to (i) impose a Passenger Facility Charge or (ii) use the Passenger Facility Charge revenue as required by the PFC legislation or PFC Regulations; (b) to restrict MAC from financing, developing or assigning new capacity at the Airport with Passenger Facility revenue if and to the extent such restriction would not violate the PFC legislation or PFC Regulations; (c) to preclude MAC from funding, developing, or assigning new capacity at the Airport with PFC revenue in any manner required by the PFC legislation or the PFC Regulations; or (d) to prevent MAC from exercising any other right it is required to retain by the PFC legislation or PFC Regulations if and to the extent it is so required to be retained by the PFC legislation or PFC Regulations.
5. Annually MAC shall submit to each Signatory Airline a report on the Capital Projects that MAC plans to commence during a Fiscal Year. MAC may from time to time amend or supplement such report for the then-current Fiscal Year by providing supplementary notice to each Signatory Airline. The report (or supplemental report) shall contain the following information:
  - a. A description of each Capital Project, together with a statement of the need for and benefits to be derived from each Capital Project.

- b. A schedule of estimated project costs and proposed funding sources for each Capital Project.
  - c. A notice requesting MII approval of the Capital Projects, if any, that are subject to MII review.
6. If MAC determines that it is in the Airport's interest to purchase improvements, equipment or to make other capital expenditures which are outside the scope of this Agreement but which may benefit an Airline, MAC may enter into a supplemental agreement with the affected Airline to provide for the payment of the costs of such purchase.

**B. CAPITAL PROJECTS SUBJECT TO MII REVIEW**

MAC may not recover through airline rents, fees, or charges the Capital Costs, including the Off-Airport Aircraft Noise Costs, of any Capital Project in the Airfield Cost Center whose gross project costs exceed five million dollars (\$5,000,000) without being approved by a Majority-in-Interest of Signatory Airlines.

1. Each Capital Project, which is subject to this Section B, shall be deemed to be "Approved by a Majority-In-Interest of Signatory Airlines" unless MAC receives, within forty-five (45) days after emailing or mailing the report specified in Section A of this Article, either: (a) written responses from a Majority-In-Interest of Signatory Airlines and such responses signify that a Majority-In-Interest of Signatory Airlines disapprove such Capital Project or (b) a certificate from the chair of the MSP Airport Affairs Committee, with supporting documentation establishing that a Majority-In-Interest of Signatory Airlines disapprove such Capital Project.
2. MAC may proceed with any Capital Project that was disapproved by a Majority-In-Interest of Signatory Airlines; provided, however, that MAC may not recover through airline rents, fees, or charges the Capital Costs, including the Off-Airport Aircraft Noise Costs, of any disapproved Capital Project.

**C. CAPITAL PROJECTS NOT SUBJECT TO MII REVIEW**

Without the prior approval of a Majority-In-Interest of Signatory Airlines, MAC may incur costs to plan, design, and construct at such time or times as it deems appropriate, and may recover through airline rents, fees, and charges the costs of the following Capital Projects:

1. Any Capital Project that is not in the Airfield Cost Center.
2. Any Capital Project in the Airfield Cost Center that is necessary to comply with a rule, regulation, or order of any governmental agency, other than an ordinance of MAC, which has jurisdiction over the operation of the Airport.
3. Any Capital Project in the Airfield Cost Center that is necessary to satisfy a final judgment against MAC rendered by a court of competent jurisdiction.

4. Any Capital Project in the Airfield Cost Center that is necessary to repair casualty damage, the cost of which exceeds the proceeds of applicable insurance; provided that the MAC may recover the Capital Cost of such repair only to the extent that the cost of reconstruction or replacement exceeds the insurance proceeds available for such purposes.

**D. MAJORITY-IN-INTEREST WAIVER**

AIRLINE agrees that MAC may include in its capital improvement program up to \$72 million per Fiscal Year (in 2018 dollars) for miscellaneous Capital Projects (“Contingency Projects”) as determined by MAC. Notwithstanding any other provision of this Agreement, these Contingency Projects may include at MAC’s discretion projects to be included in the Airfield Cost Center, and this Agreement shall be deemed to be AIRLINE’S approval (if required) of any such Capital Project without any requirement for Majority-In-Interest review.

**E. TERMINAL 1 OPERATIONAL IMPROVEMENTS PROGRAM**

MAC is in the process of planning and implementing the OI Program. The OI Program is a series of projects through 2023 to completely overhaul Terminal 1 arrivals and departures level, for the benefit of passengers and the entire Airport community. AIRLINE acknowledges that elements of the OI Program, including but not limited to the following, will materially impact and change AIRLINE’s operations both during and after the construction of the program:

1. Remodeling and relocation of airline ticket offices and baggage service offices.
2. Installation of ticket counter backwall monitors, which will be owned and maintained by MAC. Implementation of content management system to operate ticket counter backwall monitors.
3. Installation of automated bag drop devices throughout the ticket lobby.
4. Installation of new inbound baggage system.

AIRLINE agrees to cooperate with MAC in good faith to ensure the efficient and timely completion of the OI Program and acknowledges that such cooperation may require reasonable accommodation of other Airlines within AIRLINE’s Preferential Use Space and Exclusive Use Space in accordance with Section IV.E. The drawings and the estimated timelines associated with the various phases of each project associated with the OI Program are available to AIRLINE upon request of MAC. MAC shall cooperate with AIRLINE and the other Signatory Airlines and shall use commercially reasonable efforts to minimize, to the greatest extent possible, the adverse impact of the OI Program on AIRLINE’s operations.

**F. CONCOURSE G PROJECT**

Subject to finalization of plans and financing therefor, MAC intends to improve the customer experience at Concourse G of Terminal 1 by expanding, modernizing, and reallocating square footage in Concourse G intended to improve circulation, holdroom, concession, and Airline Club space to support the current Flight activities and anticipated future Flight activities at Concourse G (collectively, the “Concourse G Project”), and



AIRLINE acknowledges that MAC intends to undertake the Concourse G Project; provided, however, that AIRLINE's acknowledgement shall in no way limit MAC's rights or obligations under the MAC Board of Commissioners-adopted Capital Improvement Program (CIP); a copy of the most recent CIP is available on the MAC website.

## VIII. INSTALLATION, MAINTENANCE, AND UTILITIES

### A. OBLIGATIONS OF MAC

1. MAC shall maintain and operate the Airport in conformance with all rules and regulations of the FAA and any other governmental agency having jurisdiction thereover, provided that nothing herein contained shall be deemed to require MAC to enlarge the Airport, to make expansions or additions to the landing areas, runways or taxiways, or other appurtenances of the Airport. In limitation of the foregoing, it is expressly agreed that if funds for the provision, maintenance and operation of the control tower, instrument landing system, ground control approach and/or other air navigation aids or other facilities required or permitted by the United States and needed by AIRLINE for AIRLINE's operation at the Airport, which are now, or may hereafter be furnished by the United States, are discontinued MAC shall not be required to furnish such facilities; provided, however, that if AIRLINE cannot operate from the Airport or its operations are materially impaired due to such services no longer being provided, AIRLINE shall have the right to seek rent abatement from MAC during such period.
2. Except as otherwise specifically provided herein, MAC during the Term of this Agreement shall, in accordance with acceptable FAA standards, and other applicable statutes or regulations, operate, maintain, and keep in good repair the Airport, including vehicular parking spaces, and all appurtenances, facilities and services therein, including, without limiting the generality hereof, all field lighting and other appurtenances, facilities and services which MAC is to furnish hereunder, Common Use Space, Joint Use Space, and public space. MAC shall make repairs thereto, though caused by negligence of AIRLINE or its employees, agents, or invitees. MAC may recover from AIRLINE such portion of the cost of such repairs caused by negligence of AIRLINE or its employees, agents, or invitees as is not recoverable through MAC's insurance on such damaged or destroyed structures or facilities.
3. It is further agreed that nothing in this Agreement shall prevent MAC from making such commitments to the Federal Government or to the State of Minnesota as may be required in order to qualify for the expenditure of Federal or State funds on the Airport. Such commitments shall be without prejudice to AIRLINE's right to claim damages therefrom. In furtherance of the foregoing, MAC shall:
  - a. Keep the Airport reasonably free from obstructions, including the removal and clearing of snow, grass, stone, or other foreign matter as necessary and with reasonable promptness from the runways, taxiways and loading areas, and areas immediately adjacent thereto in order to insure the safe, convenient, and proper use of the Airport by AIRLINE and others.

- b. Keep public areas of Terminal 1 and Terminal 2 adequately supplied, equipped, furnished and decorated, and operate and maintain a public address system and adequate directional signs in Terminal 1 and Terminal 2 and throughout the Airport, including but not limited to signs indicating the location of public restaurants, restrooms, newsstands, telephones, telegraph, baggage counters, and all other facilities for passenger or public use in Terminal 1 and Terminal 2 or elsewhere on the Airport.

4. MAC shall:

Provide and supply adequate heat, conditioned air, water and adequate lighting for Terminal 1 and Terminal 2 and loading ramps, and adequate field lighting on or for the Airport (See Section IV.B. for certain obligations), and provide reasonable access to existing sewer, water, heating/cooling, electrical and other available utilities in Terminal 1 and Terminal 2, with cost of connection to be borne by Airlines. MAC shall make diligent and commercially reasonable efforts to supply AIRLINE with these services; provided, however, that if MAC makes such diligent and commercially reasonable efforts, but fails to provide any of said utilities or services, said failure shall not constitute a constructive eviction. Further, MAC shall not be liable to AIRLINE for, and AIRLINE expressly releases and discharges MAC from, any and all claims, demands and causes of action that the AIRLINE may now or hereafter have against MAC, and any reduction in rents, fees and charges, arising or alleged to have arisen out of any interruption of utility services (i) to the extent any utility shall become unavailable from any public utility company, public authority, or any other independent person or entity supplying or distributing such utility except to the extent caused by the negligence or willful misconduct of MAC, its contractor, or subcontractor or any of their respective employees, agents, or representatives, or (ii) for any interruption in any service hereunder (including, without limitation, any heating, ventilation or air-conditioning) caused by the making of any necessary repairs or improvements except to the extent caused by the negligence or willful misconduct of MAC, its contractor, or subcontractor or any of their respective employees, agents, or representatives, or (iii) which results from any cause beyond the MAC's reasonable control and not caused by the negligence or willful misconduct of MAC, its contractor, or subcontractor or any of their respective employees, agents, or representatives; provided, however, that if (a) AIRLINE suffers damages due to the negligence or willful misconduct of MAC or its employees in connection with utilities, and (b) a Majority-In-Interest of Signatory Airlines disapprove the purchase of a policy under Section VI.M that would have provided insurance coverage for such damages and as a result such damages are not covered by insurance, AIRLINE hereby waives any claim it may have against MAC or its employees for such damages to the extent they would have been covered by the aforementioned insurance.

AIRLINE hereby waives all claims to special, indirect, and consequential damages, which shall include but not be limited to, losses of use, income, profit, financing, business and reputation, that might be asserted by AIRLINE against MAC or its commissioners, officers, employees, or directors, in connection with MAC's providing or maintaining utilities, except (a) to the extent such damages arise from the gross negligence or willful misconduct of MAC or its commissioners, officers, directors, or employees, in which case AIRLINE may recover from parties and in amounts in accordance with common law unaltered by this Agreement, or (b) damages recoverable under insurance policies described herein, or would have been so recoverable if insurance had been properly maintained in accordance with this Agreement. The foregoing shall not waive any rights or obligations under Minnesota Statutes Section 466.01 *et seq.* or limit any other form of immunity available to MAC or its commissioners, officers, employees, or directors under law or at equity. All content and data feeds on utility systems shall be subject to MAC control and written approval, not to be unreasonably withheld, conditioned, or delayed; provided, however, the foregoing shall not be deemed to grant MAC any license or right to use AIRLINE's intellectual property without AIRLINE's authorization.

- a. Provide janitors and other cleaners necessary to keep the areas outlined in Exhibit P, the unleased Rentable Space, and the field and runway areas of the Airport at all times safe, clean, neat, orderly, sanitary, and presentable. AIRLINE may provide janitorial services in its Preferential Use holdroom areas if in the judgment of MAC's Executive Director the level of cleaning meets MAC's consistently applied standards.
  - b. Provide space in Terminal 1 and Terminal 2 and arrange for the professional operation of restaurants for the purpose of selling food, beverages, and merchandise to the public.
5. MAC shall perform maintenance in Terminal 1, Terminal 2, and surrounding areas in compliance with Exhibit P and as further defined in this Article. Any changes to that responsibility must be incorporated as an amendment to this Agreement.
6. MAC by its authorized officers, employees, agents, contractors, subcontractors, or other representatives, shall have the right (at such times as may be reasonable under the circumstances and with as little interruption of AIRLINE's operation as is reasonably practicable) to enter AIRLINE's Exclusive Use Space, Preferential Use Space, Joint Use Space, or Common Use Space for the following purposes:
- a. To inspect such space to determine whether AIRLINE has complied and is currently in compliance with the terms and conditions of this Agreement.
  - b. Upon reasonable notice to perform such maintenance, cleaning, or repair as MAC's Executive Director deems necessary, if AIRLINE fails to perform its obligations under this Article VIII, and to recover the reasonable cost of such maintenance, cleaning, or repair from AIRLINE.

7. With regard to the IAF, MAC shall:
  - a. Operate, maintain, and keep the IAF space in good condition and repair and shall keep it adequately supplied, equipped, furnished and decorated, and operate and maintain adequate directional signs.
  - b. Provide janitors and other cleaners reasonably necessary to keep the IAF space, including Federal office space, safe, clean, neat, orderly, sanitary, and presentable.

**B. OBLIGATIONS OF AIRLINE**

1. Subject to MAC or its contractor providing janitorial and cleaning services as specified in Section VIII.A.4 and Exhibit P and MAC's other express obligations herein, AIRLINE shall, in accordance with Exhibit P, attached hereto, be responsible for and shall perform or cause to be performed janitorial, maintenance, and repair of its Preferential Use Space and its Exclusive Use Space such that it is in a neat and orderly condition and shall repair or replace as needed all improvements, installations, fixtures and equipment to be initially installed by it hereunder. Where damage is caused by the negligence or willful misconduct of MAC, its officers, agents, or employees, AIRLINE may recover from MAC the cost of repairs to that extent but, except as set forth in Section VI.M., only to the extent that the cost of such repairs is not recoverable through insurance of AIRLINE on such improvements, installations, fixtures and equipment. AIRLINE shall not commit nor permit any waste of or to the Premises or to apron areas adjacent to AIRLINE's holdroom. Explicitly in furtherance of the foregoing the AIRLINE shall:
  - a. Whether alone or in conjunction with other Airlines at the Airport provide sufficient porter service and common bag claim service in the area designated for the convenience of AIRLINE's passengers, and
  - b. Not permit the accumulation in its Preferential Use Space or Exclusive Use Space or on the apron area adjacent to its holdroom of rubbish, debris, waste material, or anything detrimental to health or unsightly or likely to create a fire hazard, but shall make prompt disposition thereof.
2. Subject to MAC's Rules and Regulations and Ordinances and MAC Design and Construction Standards, AIRLINE may, from time to time, install additional facilities and improvements and modify or expand existing facilities or improvements in its Exclusive Use Space and Preferential Use Space, including, without limitation, installing carpet in holdrooms, updating wall finishes, and making other cosmetic changes. Before entering into any contract for such work, or commencing work with its own personnel, AIRLINE shall first submit to MAC for its prior written approval a request (in a form reasonably prescribed by MAC) accompanied by a set of complete construction plans and specifications for the proposed work. The work shall not unreasonably interfere with the operation of the Airport and Flights to and from the same on a 24 hours per day, 7 days per week basis. In completing the work approved the AIRLINE shall:
  - a. If requested by MAC (but only to the extent required by law), require the contractor and any subcontractor to furnish a performance bond and payment bond, approved as to form and substance by MAC.

- b. Deliver to MAC “as built” drawings, if applicable, of the work actually performed by it and shall keep such drawings current showing any changes or modification made in or to its Exclusive Use Space and Preferential Use Space.
3. With regard to the IAF, AIRLINE is responsible for handling and disposing of all international waste on AIRLINE’s aircraft in accordance with the applicable requirements of the United States Department of Agriculture.

**C. OPERATION AND MAINTENANCE OF OUTBOUND BHS**

1. MAC owns the Outbound BHS. As a matter of efficiency, MAC desires DELTA to operate and maintain the Outbound BHS. In consultation with DELTA, MAC will provide the technology infrastructure necessary to host the system, including physical rooms, network and server/storage equipment. Therefore, notwithstanding anything to the contrary contained in this Agreement, but subject to the terms of this Section, DELTA and MAC have agreed that DELTA will, in accordance with acceptable FAA and TSA standards, and other applicable statutes or regulations, operate, maintain and keep in good repair the Outbound BHS. In performing such services:
  - a. DELTA and MAC have agreed that DELTA will train its personnel or cause its contractors to train their personnel in proper baggage system maintenance procedures.
  - b. DELTA and MAC have agreed that DELTA will operate, maintain and repair (or cause its contractor to operate, maintain and repair) the Outbound BHS according to manufacturer’s specifications, if any, and in accordance with industry practices.
  - c. DELTA and MAC have agreed that DELTA records of such training and maintenance will be kept by DELTA and summaries of this information will be made available to MAC as requested. Such maintenance reports will include activities related to predictive (*i.e.*, replacement of wear parts) and preventative (*i.e.*, lubrication, exercise, etc.) maintenance as well as any corrective maintenance.
  - d. Except with respect to the Baggage Re-Controls Project being constructed by DELTA on MAC’s behalf, no equipment modifications or additions will be made to the Outbound BHS without MAC’s advance written consent.
  - e. DELTA and MAC have agreed that DELTA’s operation and maintenance responsibilities for the Outbound BHS shall include purchase of any necessary maintenance parts and supplies as well as spare part replacement; provided, however, MAC shall make available to DELTA for performance of these services the spare parts from initial construction of the Outbound BHS and shall assist DELTA and its contractor in enforcing warranty claims against the supplier and installation contractor for the Outbound BHS.

- f. Except with respect to the Baggage Re-Controls Project being constructed by DELTA on MAC's behalf, DELTA and MAC have agreed that DELTA's operation and maintenance responsibilities for the Outbound BHS shall not include any obligation to incur Capital Costs or to undertake any Capital Project in connection with the Outbound BHS; provided, however, for purposes of the Outbound BHS, a "Capital Project" shall include without limitation the performance of any extraordinary, non-recurring major maintenance of the Outbound BHS, provided that any single item of the foregoing has a Capital Cost of \$30,000 or more and a useful life in excess of three years.
  - g. MAC and DELTA have agreed to cooperate on the information technology roles required by each party to accomplish the responsibilities set forth in this Section.
2. MAC shall reimburse DELTA for its actual costs, without markup, of operating and maintaining the Outbound BHS as follows:
- a. On or about September of each year, DELTA and MAC have agreed that DELTA will submit to MAC for MAC's approval, which approval shall not be unreasonably withheld, conditioned, or delayed, a maintenance schedule and budget for the Outbound BHS for the upcoming Fiscal Year. The budget will include DELTA's estimate of amounts to be paid to DELTA's contractors and employees (at fully-loaded rates) for performing the services. The budget will also include a pass-through of all rental and other charges assessed by MAC to DELTA for storage space that is used exclusively in connection with DELTA's operation and maintenance services for the Outbound BHS for such Fiscal Year (initially estimated at 3,500 square feet). The budget, as approved by MAC for a Fiscal Year, is referred to herein as the "Outbound BHS Budgeted Cost."
  - b. The Outbound BHS Budgeted Cost for a Fiscal Year shall be prorated between DELTA, on the one hand, and the other Airlines that use the Outbound BHS, on the other hand, on the basis of that proportion which the number of DELTA's Enplaned Passengers at Terminal 1 (on the one hand) and the other Airlines Enplaned Passengers at Terminal 1 (on the other hand) for such Fiscal Year bears to the total number of Enplaned Passengers of all such Airlines (DELTA and other Airlines) at Terminal 1 for such Fiscal Year.
  - c. MAC shall pay DELTA, or credit against DELTA's rents, fees and charges owed by DELTA to MAC under DELTA'S Lease, on a quarterly basis, the other Airlines' share (as determined in Section VIII.C.2.b above) of the Outbound BHS Budgeted Cost. MAC shall allocate the other Airlines' share (as determined in Section VIII.C.2.b above) of the Outbound BHS Budgeted Cost to the other Airlines by using the Joint Use Formula (omitting DELTA and its Enplaned Passengers from the calculation) and collect such amounts directly from the other Airlines.

- d. If a Signatory Airline fails to pay its share of the Outbound BHS Budgeted Cost in a timely fashion, such costs may be added to an appropriate Airport Cost Center, at MAC's sole discretion.
  - e. DELTA and MAC have agreed that DELTA will report to MAC no later than March 1 of each year DELTA's actual costs, without markup, of operating and maintaining the Outbound BHS during the previous Fiscal Year ("Outbound BHS Actual Cost"). DELTA and MAC have agreed that such report will be supported by back-up documentation to the reasonable satisfaction of MAC. The Outbound BHS Actual Cost will be reconciled against the Outbound BHS Budgeted Cost for such Fiscal Year and all payments based thereon shall be adjusted according to Section VI.H.
3. For and in consideration of DELTA's agreement to provide the operation and maintenance services for the Outbound BHS, AIRLINE hereby waives all claims to special, indirect, and consequential damages that might be asserted by AIRLINE against DELTA, MAC or their respective officers, directors, contractors, employees or agents in connection with the maintenance and operation of the Outbound BHS. AIRLINE agrees that DELTA is an express third party beneficiary of such waiver.
  4. Notwithstanding anything to the contrary contained in this Lease, if an event of default occurs under Section VIII.C of DELTA's lease due to DELTA's failure to perform its operation and maintenance obligations with respect to the Outbound BHS, MAC's sole remedy shall be for actual, direct damages and/or to terminate DELTA's right and obligation to operate and maintain the Outbound BHS.
  5. Notwithstanding anything to the contrary contained in the Agreement, DELTA may elect at a time upon no less than 180 days' advance notice to MAC to cease performing operation and maintenance services with respect to the Outbound BHS.
  6. If DELTA ceases to operate and maintain the Outbound BHS pursuant to Section VIII.C.4 or VIII.C.5 above, MAC shall appoint such other contractor or Airline to perform such services as MAC deems appropriate. Thereafter, DELTA's share (calculated as described in Section VIII.C.2.b) of MAC's or such third-party provider's actual costs of operating and maintaining the Outbound BHS shall be included in DELTA's rents, fees and charges under this Lease and MAC's payment obligation under Section VIII.C.2.c shall terminate.

7. Except as stated in this Section VIII.C, in no event shall MAC have any affirmative duty to operate, maintain, or repair the Outbound BHS, or pay for its operation, maintenance, or repair.
8. Future upgrades to the Outbound BHS may become necessary over time and MAC and DELTA have agreed to meet and mutually negotiate the scope and funding of those upgrades which will be subject to MAC Board approval.
9. Notwithstanding DELTA's or other MAC contractor's operation and maintenance of the Outbound BHS, if AIRLINE's operations unreasonably interfere with the operation of the Outbound BHS as determined by MAC in its sole yet reasonable discretion, MAC shall provide a warning to AIRLINE the first time this occurs in a twelve (12) month period. For any subsequent unreasonable interference in a twelve (12) month period, \$1,000 shall be assessed to AIRLINE as liquidated damages for each such unreasonable interference. The liquidated damages calculated pursuant to this Section are not intended as a penalty. The liquidated damages above are in addition to any other remedy available to MAC under this Agreement, at law, or in equity. Any liquidated damages collected pursuant to this Section VIII.C.9. shall be applied to reduce the carousel and conveyor charges or, if DELTA is maintaining the Outbound BHS, shall be provided to DELTA to reduce the overall Outbound BHS cost.

**D. OPERATION AND MAINTENANCE OF INBOUND BHS**

1. MAC owns the Inbound BHS. As a matter of efficiency, MAC desires DELTA to operate and maintain the Inbound BHS. Effective January 1, 2019, or another date mutually agreed to by MAC staff and DELTA, subject to the terms of this Agreement, DELTA and MAC have agreed that DELTA will, in accordance with acceptable FAA and TSA standards, and other applicable statutes or regulations, operate, maintain and keep in good repair the Inbound BHS. In performing such services:
  - a. DELTA and MAC have agreed that DELTA will train its personnel or cause its contractors to train their personnel in proper baggage system maintenance procedures.
  - b. DELTA and MAC have agreed that DELTA will operate, maintain and repair (or cause its contractor to operate, maintain and repair) the Inbound BHS according to manufacturer's specifications, if any, and in accordance with industry practices.
  - c. DELTA and MAC have agreed that DELTA that computerized records of such training and maintenance will be kept by DELTA and summaries of this information will be made available to MAC as requested. Such maintenance reports will include activities related to predictive (*i.e.*, replacement of wear parts) and preventative (*i.e.*, lubrication, exercise, etc.) maintenance as well as any corrective maintenance.



- d. Except as expressly set forth herein, no equipment modifications or additions will be made to the Inbound BHS without MAC's advance written consent.
  - e. DELTA and MAC have agreed that DELTA's operation and maintenance responsibilities for the Inbound BHS will include purchase of any necessary maintenance parts and supplies as well as spare part replacement; provided, however, MAC shall make available to DELTA for performance of these services the spare parts from initial construction of the Inbound BHS and MAC shall assist DELTA and its contractor in enforcing warranty claims against the supplier and installation contractor for the Inbound BHS.
  - f. DELTA's operation and maintenance responsibilities for the Inbound BHS shall not include any obligation to incur Capital Costs or to undertake any Capital Project in connection with the Inbound BHS; provided, however, for purposes of the Inbound BHS, a "Capital Project" shall include without limitation the performance of any extraordinary, non-recurring major maintenance of the Inbound BHS, provided that any single item of the foregoing has a Capital Cost of \$30,000 or more and a useful life in excess of three years.
2. MAC shall reimburse DELTA for its actual costs, without markup, of operating and maintaining the Inbound BHS as follows:
- a. On or about September of each year, DELTA and MAC have agreed that DELTA will submit to MAC for MAC's approval, which approval shall not be unreasonably withheld, conditioned, or delayed, a maintenance schedule and budget for the Inbound BHS for the upcoming Fiscal Year. The budget will include DELTA's estimate of amounts to be paid to DELTA's contractors and employees (at fully-loaded rates) for performing the services. The budget will also include a pass-through of any rental and other charges assessed by MAC to DELTA for storage space that is used exclusively in connection with DELTA's operation and maintenance services for the Inbound BHS. The budget, as approved by MAC for a Fiscal Year, is referred to herein as the "Inbound BHS Budgeted Cost."
  - b. The Inbound BHS Budgeted Cost for a Fiscal Year shall be allocated among the Airlines at Terminal 1 using the Joint Use Formula for such Fiscal Year.
  - c. MAC shall pay DELTA, or credit against DELTA's rents, fees and charges owed by DELTA to MAC under DELTA'S Lease, on a quarterly basis, the other Airlines' share (as determined in Section VIII.D.2.b above) of the Inbound BHS Budgeted Cost.
  - d. If any Signatory Airline fails to pay its share of the Inbound BHS Budgeted Cost in a timely fashion, such costs may be added to an appropriate Airport Cost Center, at MAC's sole discretion.

- e. DELTA and MAC have agreed that DELTA will report to MAC no later than March 1 of each Fiscal Year DELTA's actual costs, without markup, of operating and maintaining the Inbound BHS during the previous Fiscal Year ("Inbound BHS Actual Cost"). Such report shall be supported by back-up documentation to the reasonable satisfaction of MAC. The Inbound BHS Actual Cost will be reconciled against the Inbound BHS Budgeted Cost for such Fiscal Year and all payments based thereon will be adjusted according to Section VI.H. Any Inbound BHS Actual Costs that are not paid by a Signatory Airline, plus any costs incurred by MAC for the Inbound BHS, may be added to an appropriate cost center, at MAC's sole discretion.
3. For and in consideration of DELTA's agreement to provide the operation and maintenance services for the Inbound BHS, AIRLINE hereby waives all claims to special, indirect, and consequential damages that might be asserted by AIRLINE against DELTA, MAC or their respective officers, directors, contractors, employees or agents in connection with the maintenance and operation of the Inbound BHS. AIRLINE agrees that DELTA is an express third party beneficiary of such waiver.
4. Notwithstanding anything to the contrary contained in this Agreement, if an event of default occurs under Section VIII.D of DELTA's lease due to DELTA's failure to perform its operation and maintenance obligations with respect to the Inbound BHS, MAC's sole remedy shall be for actual, direct damages and/or to terminate DELTA's right and obligation to operate and maintain the Inbound BHS.
5. Notwithstanding anything to the contrary contained in this Agreement, DELTA may elect at any time upon no less than 180 days' advance notice to MAC to cease performing operation and maintenance services with respect to the Inbound BHS.
6. As part of DELTA's operation and maintenance of the Inbound BHS, DELTA has agreed, after consulting with MAC and other Terminal 1 Airlines, to assign and/or allocate the baggage carousels and other related belts and components in a reasonable and nondiscriminatory manner so that the Inbound BHS functions as intended and provides all Deplaning Passengers at Terminal 1 with checked baggage with reasonable access to the Inbound BHS. DELTA has agreed to reasonably cooperate with MAC and other Terminal 1 Airlines to develop procedures to assign and/or allocate the baggage carousels and other related belts and components. To the extent AIRLINE uses the Inbound BHS, AIRLINE agrees to reasonably cooperate with MAC and DELTA regarding assignment and allocation of the baggage carousels and other related belts and components.
  - a. If MAC or another Terminal 1 Airline believes DELTA is not assigning and/or allocating the baggage carousels and other related belts and components in the manner described above or DELTA is not following any applicable baggage carousel assignment or allocation procedures, such Airline or MAC, as applicable, must first attempt to cooperate with

- DELTA to address its concerns. If, after a reasonable attempt by MAC or such Airline and DELTA to cooperate to address such concerns, MAC shall investigate the alleged issue (if it hasn't already) and MAC may, but it not required to either:
- (a) (i) request DELTA assign or allocate the baggage carousels and other related belts and components in a specific manner to address such concerns, and (ii) if DELTA agrees with such assignment or allocation, DELTA agrees to implement such direction from MAC in such manner, or (b), if DELTA does not agree with such assignment or allocation, MAC may, after sixty (60) days' notice take over responsibility from DELTA for allocating and/or assigning the baggage carousels and other related belts and components, and DELTA agrees to relinquish such responsibility to MAC in such case, provided that (x) MAC shall assign and/or allocate the baggage carousels and other related belts and components in a reasonable and nondiscriminatory manner so that the Inbound BHS functions as intended and provides all Deplaning Passengers at Terminal 1 with checked baggage with reasonable access to the Inbound BHS, and (y) MAC shall reasonably cooperate with DELTA and other Terminal 1 Airlines to develop procedures to assign and/or allocate the baggage carousels and other related belts and components.
  - b. MAC may, if approved by a Majority-In-Interest of the Terminal 1 Signatory Airlines (excluding Affiliated Airlines) in accordance with the procedures in Section VII.B.1, implement a dynamic baggage allocation system in the Inbound BHS. In such event, DELTA shall integrate the dynamic baggage allocation system into operations consistent with the general requirements of this provision and MAC, DELTA, and other Terminal 1 Airlines will cooperate to develop the dynamic baggage allocation system procedures, rules, and parameters.
7. If DELTA ceases to operate and maintain the Inbound BHS pursuant to Section VIII.D.4 or VIII.D.5 above, MAC shall appoint such other contractor or Airline to perform such services as MAC deems appropriate. Thereafter, DELTA's share (calculated as described in Section VIII.D.2.b) of MAC's or such third-party provider's actual costs of operating and maintaining the Inbound BHS shall be included in DELTA's rents, fees and charges under this Lease and MAC's payment obligation under Section VIII.D.2.c shall terminate.
  8. Except as stated in this Section VIII.D, in no event shall MAC have any affirmative duty to operate, maintain, or repair the Inbound BHS, or pay for its operation, maintenance, or repair.

**E. PASSENGER BOARDING BRIDGES (PBBs)**

1. Provision or Replacement of PBBs

AIRLINE acknowledges that MAC may, at its discretion, provide or replace AIRLINE-owned or MAC-owned passenger boarding bridges and associated equipment where required (e.g. 400 Hz power, pre-conditioned air, luggage lifts, etc.) (“PBB(s)”) within Terminal 1.

2. Ownership and Disposal

- a. As of the date of this Agreement, MAC owns the PBBs within Terminal 1 as shown below identified by the PBBs gate number. PBBs not shown below are owned either by AIRLINE or other Signatory Airlines at the Airport. Concourse A gates, Concourse B gates, C1-C8, C11-C27, D1, D5, D6, E1-E6, E11, E13, E15, F5, F8, F10-F16, G1, G2, G4, G5, G6A/B, G8, G9, G19, G20, G22.
- b. If MAC replaces an AIRLINE-owned PBB, AIRLINE agrees to transfer the existing PBB, without warranty of any kind, to MAC at no charge and MAC agrees to dispose of the existing PBB and incorporate any salvage value into the PBB replacement project. AIRLINE shall provide MAC with a Bill of Sale or Transfer Agreement in a form reasonably acceptable to MAC and AIRLINE.
- c. Where applicable and as directed by AIRLINE, AIRLINE agrees to remove and relocate an existing PBB at no cost to MAC. Existing PBBs may be designated for refurbishment instead of being disposed.
- d. MAC will pay for and own all PBBs that it elects to replace per this Section E.

3. Maintenance and Operation

AIRLINE is responsible for all maintenance, repair, and operation of PBBs that AIRLINE owns, and shall pay all costs of maintaining, repairing and operating the PBBs that AIRLINE owns.

For Terminal 1 only, AIRLINE is responsible for all maintenance, repair, and operation of PBBs owned by MAC that AIRLINE uses, and shall pay all costs of maintaining, repairing and operating those PBBs; and shall comply with the following conditions relating to equipment training, maintenance and potential equipment modification needs.

- a. AIRLINE will train its personnel in proper PBB maintenance procedures in accordance with the recommendations and requirements noted in the training section of the O & M manuals that come with each bridge.
- b. AIRLINE will operate and maintain the PBB according to the manufacturer's specifications as again outlined in the associated O & M manual(s), or as modified by mutual agreement with MAC. Purchase of any necessary maintenance parts and supplies as well as spare part replacement shall be the responsibility of the AIRLINE. Computerized records of such training and maintenance will be kept by the AIRLINE and summaries of this information will be made available to MAC on an as requested basis. Such maintenance reports shall include activities related to predictive (i.e. replacement of wear parts) and preventative (i.e. lubrication, exercise, oil changes, etc.) maintenance as well as any corrective maintenance.
- c. Air conditioning units shall be considered as appurtenances integral to the PBB, and will be operated and maintained by the AIRLINE under the same O & M conditions as outlined in this Agreement.
- d. No equipment modifications or additions will be made without MAC's advance written consent as outlined in the standard MAC construction permit process.
- e. On or about July 1 of each year, AIRLINE shall submit to MAC for MAC's approval, which approval shall not be unreasonably withheld or denied, a 12-month maintenance schedule for each MAC-owned PBB being maintained by AIRLINE.
- f. AIRLINE shall report to MAC no later than March 1 any repair and maintenance completed on each PBB within the past Fiscal Year, and the cost expended for all repairs and maintenance.
- g. AIRLINE shall make the MAC owned PBB's available for use by other airlines that use AIRLINE's gates without additional charge.

In the event that AIRLINE fails, after the applicable notice and cure period, to meet its responsibilities under this Section VIII.E.3, MAC shall have the right, but no obligation, to perform any such responsibilities. AIRLINE shall reimburse MAC upon demand for any costs incurred by MAC plus an administrative fee of fifteen percent (15%) of such costs.

Notwithstanding anything to the contrary, AIRLINE's operation and maintenance responsibilities for MAC owned PBBs shall not include any obligation to incur Capital Costs or to undertake any Capital Project in connection with the PBBs unless such Capital Project is a direct result of AIRLINE not maintaining such PBB in accordance with this Section; provided, however, for purposes of the PBBs, a "Capital Project" shall include without limitation the performance of any extraordinary, non-recurring major maintenance of the PBBs, provided that any single item of the foregoing has a Capital Cost of \$30,000 or more and a useful life in excess of three years.

4. Insurance and Indemnification

AIRLINE agrees to indemnify and hold harmless MAC for the use and operation of any PBBs by AIRLINE, its Affiliated Airlines or its subtenants as and to the extent required by the general indemnity set forth in Section X.A.

5. Accessibility

AIRLINE is responsible for the provision of accessible facilities related to the use of both AIRLINE-owned and MAC owned PBBs used by AIRLINE to individuals with disabilities, if and to the extent required by applicable federal laws and regulations, including 49 CFR 27 and applicable Americans with Disabilities Act rules of the Department of Transportation and Department of Justice for airport operators. AIRLINE is responsible for the provision of accessible services related to the use of all PBBs used by AIRLINE to individuals with disabilities, if and to the extent required by applicable federal laws and regulations, including applicable Air Carrier Access Act rules for carriers.

**IX. DAMAGE OR DESTRUCTION OF PREMISES**

**A. DAMAGE OR DESTRUCTION**

1. If any building of MAC in which AIRLINE occupies Premises hereunder shall be partially damaged by fire, explosion, the elements, the public enemy, or other casualty, but shall not be rendered thereby untenable, the same shall be repaired with due diligence by MAC. If the damage shall be so extensive as to render such building untenable in whole or in part but capable of being repaired in ninety (90) days, the same shall be repaired with due diligence by MAC and the rent payable hereunder with respect to the portion of AIRLINE's Premises so rendered untenable shall be proportionately paid up to the time of such damage and shall thence forth cease and be abated until such time as such untenable portion of such building shall be fully restored to tenable condition.
2. If any such building is completely destroyed by fire, explosion, the elements, the public enemy, or other casualty, or be so damaged that the same cannot reasonably be repaired with due diligence by MAC within ninety (90) days of such casualty, MAC shall, within sixty (60) days of such casualty give AIRLINE written notice that it intends or does not intend to repair or reconstruct such building, as follows:
  - a. If MAC elects to repair and reconstruct the building, then the same shall be repaired with due diligence by MAC and the rent payable hereunder with respect to the portion of AIRLINE's Premises rendered untenable as a result of such casualty shall be proportionately paid up to the time of such casualty and shall thenceforth cease and be abated until such time as such untenable portion of such building shall be restored to tenable condition.

- b. If MAC determines not to repair or reconstruct such building (whether by delivery of notice to said effect or by deemed notice as hereinafter described), then this Agreement shall be deemed terminated as to the portion of the AIRLINE's Premises rendered untenable as a result of such casualty with respect to such portion, and rent payable hereunder with respect to such portion shall be proportionately paid through the date of such casualty and shall thenceforth cease.  
  
If no written notice of intention to repair and restore is timely received by AIRLINE within the above-referenced sixty (60) day period, then MAC shall be deemed to have elected not to repair or reconstruct the building. Except as expressly set forth in this Article IX, MAC shall have no obligation to repair or rebuild any of the facilities at the Airport in the event of damage by the elements, fire, explosions or other casualty or causes beyond the control of MAC.
- c. Proceeds of any insurance maintained by MAC payable with respect to such casualty shall be applied to such repair or reconstruction or shall be credited to the appropriate Airport Cost Centers.

**B. FORCE MAJEURE**

Except as expressly provided in this Agreement, neither MAC nor AIRLINE shall be deemed to be in default hereunder if either party is prevented from performing any of the obligations, other than payment of rents, fees and charges hereunder, by reason of strikes, boycotts, labor disputes, embargoes, shortages of energy or materials, acts of the public enemy, terrorism, weather conditions and the results of acts of nature, riots, rebellion, sabotage, or any other similar circumstances for which it is not responsible or which are not within its control.

**X. INDEMNITY AND LIABILITY INSURANCE**

**A. INDEMNIFICATION**

1. AIRLINE agrees to indemnify, defend, save and hold harmless MAC and its Commissioners, officers, and employees (collectively, "Indemnitees") from and against any and all liabilities, losses, damages, suits, actions, claims, judgments, settlements, fines or demands of any person other than an Indemnitee arising by reason of injury or death of any person, or damage to any property, including all reasonable costs for investigation and defense thereof (including but not limited to attorneys' fees, court costs, and expert fees), of any nature whatsoever arising out of or incident to (a) the use or occupancy of, or operations of AIRLINE at or about the Airport (unless such use or occupancy or operations are pursuant to another agreement with MAC that provides for indemnification under its terms in which case those terms shall apply), or (b) the acts or omissions of AIRLINE's officers, agents, employees, contractors, subcontractors, licensees, or invitees,

regardless of where the injury, death or damage may occur (unless such acts or omissions are pursuant to another agreement with MAC that provides for indemnification under its terms in which case those terms shall apply), unless such injury, death or damage is caused by (i) the negligent act or omission or willful misconduct of an Indemnitee whether separate or concurrent with negligence of others, including AIRLINE or (ii) the breach by an Indemnitee of this Agreement. MAC shall give AIRLINE reasonable notice of any such claims or actions. In indemnifying or defending MAC, AIRLINE shall use legal counsel reasonably acceptable to MAC and shall control the defense of such claim or action.

2. AIRLINE further agrees that if a prohibited incursion into the Air Operations Area occurs, or the safety or security of the Air Operations Area, the Airfield, or other sterile area safety or security is breached by or due to the negligence or willful act or omission of any of AIRLINE's employees, agents, or contractors and such incursion or breach results in a civil penalty action being brought against the MAC by the U.S. Government, AIRLINE agrees to reimburse MAC for all expenses, including attorney fees, incurred by MAC in defending against the civil penalty action and for any civil penalty or settlement amount paid by MAC as a result of such incursion or breach of airfield or sterile area security; provided, however, MAC shall allow AIRLINE to participate in both the defense of, and any settlement discussions to resolve, such civil penalty. MAC shall notify AIRLINE of any allegation, investigation, or proposed or actual civil penalty sought by the U.S. Government for such incursion or breach. Civil penalties and settlement and associated expenses reimbursable under this Paragraph include but are not limited to those paid or incurred as a result of violation of 49 CFR 1542, "Airport Security," FAR Part 108, "Airplane Operator Security," or FAR Part 139, "Certification and Operations: Land Airports Serving Certain Air Carriers."
3. The provisions of this Article shall survive the expiration of this Agreement with respect to matters arising before such expiration or before early termination or before relinquishment of Premises.

## **B. LIABILITY INSURANCE**

1. AIRLINE shall provide, without cost or expense to MAC, and maintain in force throughout the full Term hereof the following insurance coverages as appropriate, insuring AIRLINE and MAC against the liabilities set forth in Subsection A next above:
  - a. Aircraft liability insurance and comprehensive general public liability insurance for claims of property damage, bodily injury, or death allegedly resulting from AIRLINE's activities into, on, and leaving any part of the Airport, in an amount not less than four hundred million dollars (\$400,000,000) per occurrence for Airlines operating aircraft over one hundred (100) seats, and not less than two hundred million dollars (\$200,000,000) for Airlines operating aircraft with ninety-nine (99) or fewer seats, and not less than one hundred million dollars (\$100,000,000) for Airlines operating aircraft with fifty-nine (59) or fewer seats. For purposes of this Section, the number of seats is determined based upon the largest aircraft in AIRLINE's fleet.



- b. Liquor liability insurance for any facility of AIRLINE serving alcoholic beverages on the Airport in an amount not less than ten million dollars (\$10,000,000).
  - c. Hangarkeepers liability insurance in an amount adequate to cover any non-owned property in the care, custody and control of AIRLINE on the Airport, but in any event in an amount not less than ten million dollars (\$10,000,000).
  - d. Automobile liability insurance in an amount adequate to cover vehicles operating on the Airport in an amount not less than five million dollars (\$5,000,000) combined single limit.
2. Notwithstanding anything to the contrary in this Article, MAC may allow the insurance coverage required herein to be provided through a self-insurance plan established by AIRLINE. The self-insurance plan may consist of a combination of primary, excess umbrella insurance and self-insurance protection and must be no less than the limits stated in the Article. The self-insurance plan must be approved in writing by MAC prior to becoming effective at the Airport. If AIRLINE requests MAC's approval of a self-insurance plan, it must submit a copy of its self-insurance plan current financial statements annually showing the limits of its established self-insurance retention and proof of the primary and excess umbrella insurance, provided AIRLINE shall not be required to submit such financial statements if such financial statements are available at no charge through public sources. If the self-insurance plan is approved by the MAC and becomes effective, AIRLINE shall not increase the self-insurance retention levels stated in the self-insurance plan approved by MAC.
  3. MAC, in operating the Airport, will carry and maintain comprehensive general liability insurance in such amounts as would normally be maintained by public bodies engaged in carrying on similar activities. MAC presently carries three hundred million dollars (\$300,000,000) of comprehensive general liability insurance.
  4. MAC reserves the right to reasonably adjust the limits of coverage required hereunder from time to time throughout the period of this Agreement. In such event, MAC shall provide AIRLINE with written notice of such adjusted limits and AIRLINE shall comply within sixty (60) days of receipt thereof to the extent such coverage is available on commercially reasonable terms to AIRLINE.
  5. All policies of insurance required herein shall be with companies reasonably acceptable to MAC that are licensed, authorized, eligible, or admitted to conduct business with in the State of Minnesota and having a current A.M. Best Key Rating of at least A- VII or its international equivalent and shall name MAC as an additional insured to the extent AIRLINE is required to indemnify MAC

pursuant to Subsection A above. AIRLINE shall provide a copy of the additional insured endorsement to such policy at MAC's request. Each such policy shall provide that such policy may not be materially changed (e.g., coverage limits reduced below the minimum specified in this Agreement) or otherwise materially altered, or cancelled by the insurer during its term without first giving at least thirty (30) days written notice to MAC. Certificates of valid policies of insurance with required coverages shall be delivered to MAC. AIRLINE agrees to allow MAC to inspect, at AIRLINE's headquarters, any insurance policies required of AIRLINE under this Agreement upon reasonable notice to AIRLINE if reasonably necessary in MAC's capacity as an additional insured (or if MAC was required to be an additional insured hereunder and AIRLINE failed to include MAC as an additional insured, in connection with a claim against MAC); provided, however, that an AIRLINE representative shall have the right to be present at such inspection and neither MAC nor its employees, contractors, or representatives, may take any photographs, make any copies, or otherwise reproduce, in whole or in part, any portion of the policies nor shall such persons or entities disclose the contents thereof outside of MAC unless such disclosure is required due to pursuit of a claim by or against MAC under such insurance in its capacity as an additional insured. MAC and AIRLINE understand and agree that MAC is obligated to protect trade secret data in accordance with the Minnesota Government Data Practices Act and further, that MAC shall give AIRLINE reasonable opportunity to demonstrate the trade secret status of any data relating to AIRLINE's insurance, and to procure a court order protecting the same, prior to MAC's release of the same.

6. Before the expiration of any then current policy of insurance, AIRLINE shall deliver to MAC evidence that such insurance coverage has been renewed.
7. If at any time AIRLINE shall fail to obtain or to maintain in force the insurance required herein, MAC may notify AIRLINE of its intention to purchase such insurance for AIRLINE's account. If AIRLINE has not delivered evidence of insurance to MAC before the date on which the current insurance expires, MAC may provide such insurance by taking out policies in companies satisfactory to it. Such insurance shall be in amounts no greater than those stipulated herein or as may be in effect from time to time. The amount of the premiums paid for such insurance by MAC shall be paid by AIRLINE upon receipt of MAC's billing therefor, with interest at the prime interest rate announced by a major money center bank.
8. MAC shall cause Terminal 1 and Terminal 2 including the loading piers, but exclusive of improvements, facilities and fixtures constructed or installed by AIRLINE and concessionaires as their separate leasehold improvements, to be insured throughout the Term of the Agreement for not less than 90 percent of its and their full insurable value against perils of fire, extended coverage, vandalism, and malicious mischief. MAC shall also carry boiler and pressure vessel explosion, sprinkler leakage and glass breakage insurance. AIRLINE shall be relieved from liability under this Article X and Commission waives all right of recovery from AIRLINE hereunder for damage or destruction of its property insured hereunder to the extent but not beyond the extent that such cost of repair is recoverable through such insurance provided, however, that AIRLINE shall reimburse the Commission for any increase in premium resulting from inclusion therein of a waiver of subrogation endorsement.

9. AIRLINE shall cause all improvements, installations, fixtures and equipment installed by it hereunder to be insured throughout the Term of the Agreement for not less than 90 percent of their full insurable value against perils of fire, extended coverage, vandalism and malicious mischief, and with pressure vessel coverage.

**C. OTHER INSURANCE**

Subject to Section VI.M., MAC may carry additional insurance in such amounts and of such types as would normally be maintained by public bodies engaged in carrying on similar activities.

**D. ENVIRONMENTAL LIABILITY**

1. Indemnification

AIRLINE hereby indemnifies and agrees to defend, protect, and hold harmless, MAC and its Commissioners, officers, employees and agents, and their respective successors (hereafter "Environmental Indemnitees"), from and against any and all losses, liabilities, fines, damages, injuries, penalties, response costs, or claims of any and every kind whatsoever paid, incurred or asserted against, or threatened to be asserted against, any Environmental Indemnitee, relating to or regarding the release of any Environmentally Regulated Substances or violation of Environmental Laws arising out of or as a result of AIRLINE'S use or Lease of the Premises, including both within the Premises and on the Airport, (hereinafter "Environmental Claims") including, without limitation: (a) all consequential damages; (b) the reasonable costs of any investigation, study, removal, response or remedial action, as well as the preparation and implementation of any monitoring, closure or other required plan or response action (i) as and to the extent required under applicable Environmental Laws for the current use of the affected portions of the Airport, as directed by the MPCA or other regulating authority, or (ii) as to the extent required by applicable Environmental Laws or the MPCA to allow for a Planned Future Use; (c) all reasonable costs and expenses incurred by any Environmental Indemnitee in connection therewith, including but not limited to, reasonable attorneys' fees and reasonable fees for professional services or firefighting or pollution control equipment related to spills, releases or unintended discharges; and (d) any costs arising from any inaccuracy, incompleteness, breach or misrepresentation under Subsections D.2. of this Article and Section XVI.B.4. of this Agreement. This indemnification, and AIRLINE's obligations hereunder, shall survive the cancellation, termination or expiration of the Term of this Agreement with respect to matters arising prior thereto. This indemnity and not the general indemnity shall govern AIRLINE's indemnification, defense, and hold harmless obligations for Environmental Claims.

2. Claims Relating to Environmentally Regulated Substances

AIRLINE represents and warrants that subsequent to November 1, 1989, to the best of AIRLINE's actual knowledge, except as previously disclosed to the MAC or any applicable regulatory body as required, (a) no enforcement, investigation, cleanup, removal, remedial or response action or other governmental or regulatory actions have been asserted against AIRLINE with respect to the Premises, pursuant to any Environmental Laws or relating to Environmentally Regulated Substances; (b) no violation or noncompliance with Environmental Laws has occurred with respect to AIRLINE's past or present operations conducted on the Premises; (c) no claims have been made or been threatened by any third party against the AIRLINE with respect to the Premises relating to Environmental Laws or Environmentally Regulated Substances, including by any governmental entity, agency or representative (collectively "Governmental Entity").

3. Testing and Reports

AIRLINE shall provide to MAC within ten (10) business days of request, a copy of any notice regarding violation of any Environmental Law arising out of AIRLINE's past or present operations on the Premises, a copy of any inquiry regarding violations by Environmental Law arising out of AIRLINE's past or present operations on the Premises by any Governmental Entity, a copy of any reports required by the Environmental Laws regarding violation of any Environmental Law arising out of AIRLINE's past or present operation of the Premises, or a copy of any notice of the emission or release of Environmentally Regulated Substances in violation of any Environmental Law arising out of AIRLINE's past or present operations on the Premises. If MAC has a reasonable basis to believe that AIRLINE is not meeting the obligations of Section XVI.B.3. of this Agreement, MAC may by notice require AIRLINE to conduct a reasonable review of its records for such documents as MAC reasonably believes have not been provided and submit any such documents as required.

4. Notification

AIRLINE shall notify MAC in writing within fifteen (15) business days of any matter that AIRLINE obtains knowledge of that may give rise to an indemnified claim under Subsection D.1. of this Article or that constitutes any emission or release or any threatened emission or release of any Environmentally Regulated Substance in, on, under or about the Premises or the Airport arising out of AIRLINE's past or present operations which is or may be in violation of the Environmental Laws. AIRLINE shall promptly follow the notification procedures outlined in the MSP Integrated Spill Response and Coordination Plan ("Integrated Plan") regarding any spills, releases or accidental discharges that occur on the Airport. AIRLINE shall use commercially reasonable efforts to notify MAC of any spill of Environmentally Regulated Substances at the Premises or at the Airport which requires notification to a regulatory agency pursuant to any applicable Environmental Law.

5. Right to Investigate

Subject to Subsections D.3. and D.6. of this Article, upon reasonable notice to AIRLINE, MAC shall have the right, but not the obligation or duty, at any time from and after the date of this Agreement, to investigate, study and test the Premises (at MAC's own expense, unless otherwise provided herein) during normal business hours, except under emergency circumstances, to determine whether Environmentally Regulated Substances are located in, on or under the Premises or the Airport, or were emitted or released therefrom, which are not in compliance with Environmental Laws. In conducting such investigation, MAC shall not unreasonably interfere with AIRLINE'S operations on and use of the Premises. AIRLINE shall be entitled to have a representative present during such investigation. Upon the reasonable request of MAC, AIRLINE shall provide a list of any and all Environmentally Regulated Substances used by AIRLINE at the Airport that are required to be listed in the MSP NPDES permit.

6. Right to Take Action

MAC shall have the right, but not the duty or obligation, to take whatever reasonable action it deems appropriate to protect the Premises from any material impairment to its value resulting from any escape, seepage, leakage, spillage, discharge, deposit, disposal, emission or release of Environmentally Regulated Substances from the Premises or the Airport which is not in full accordance with any Environmental Law and arises out of AIRLINE's past or present operations during the Term of this Agreement. The MAC shall notify the AIRLINE of its intention to take such action in writing thirty (30) days before proceeding under this Subsection D.6. Within that thirty (30) day period, AIRLINE shall have the opportunity to take whatever reasonable action is deemed appropriate by MAC or provide MAC a binding commitment to do so within a reasonable time. If AIRLINE does not take such action or provide a binding commitment within the thirty (30) day period, MAC may proceed under the terms of this Subsection D.6. MAC shall not be obligated to provide such 30 days' advance notice if doing so may reasonably result in material harm to person or property, but, in such circumstance, MAC shall provide as much advance notice as reasonably practicable under the circumstances. All costs associated with any action by the MAC in connection with this provision, including but not limited to reasonable attorneys' fees, shall be subject to Subsection D.1. of this Article.

7. Environmental Responsibility

a. Spill Coordination and Responsibility

AIRLINE agrees to implement the Integrated Plan. AIRLINE is obligated to ensure that it has adequate resources to respond to a discharge, including retaining a discharge recovery contractor and providing the necessary equipment to respond to a discharge, in accordance with the Integrated Plan. AIRLINE agrees to supply, upon request by MAC, a copy of AIRLINE'S Spill Prevention, Control and

Countermeasure (“SPCC”) plan, if AIRLINE is required to maintain by MPCA or EPA, which details the steps and measures AIRLINE intends to take to prevent spills from occurring on the Airport, the spill preparedness and training that AIRLINE has in place, the response actions AIRLINE intends to take and the notification procedures to be implemented by AIRLINE in the event of a spill at the Airport (caused by AIRLINE) in accordance with the Integrated Plan.

Annually, AIRLINE shall verify to MAC that it is complying with this Section D.7 and the Integrated Plan as detailed in the plan.

Subject to all other terms of this Agreement, if MAC incurs costs related to a spill or other environmental expenses related to Environmentally Regulated Substances as a result of its exercise of its rights pursuant to Section D.6 above, unless due to the gross negligence of MAC, MAC will bill AIRLINE for all MAC’s actual third party costs incurred, plus a fifteen percent (15%) administrative fee on such incurred costs, provided that such administrative fee cannot exceed \$200,000 per incident. AIRLINE shall pay MAC within thirty (30) days of AIRLINE’S receipt of the invoice. AIRLINE may then determine which AIRLINE, AIRLINE agent, AIRLINE clientele or other party, is responsible for such costs and AIRLINE may seek reimbursement from such parties at AIRLINE’s expense.

b. Minnesota Pollution Control Agency (“MPCA”) Permits

AIRLINE agrees to make application as a co-permittee on and comply with the MSP NPDES Permit.

AIRLINE (i) shall only conduct vehicle and aircraft maintenance in accordance with the applicable terms and conditions of the MSP NPDES Permit, and (ii) shall only store waste materials outside in accordance with the applicable terms and conditions of the MSP NPDES permit. AIRLINE shall ensure its dumpsters are covered at all times except when being filled with waste and shall prevent its equipment from having releases to stormwater.

AIRLINE is prohibited from, to the extent in violation of the MSP NPDES permit, discharging wash waters with detergents or containing Environmentally Regulated Substances to stormwater, except as provided below. For products containing Environmentally Regulated Substances that may be exposed to stormwater as part of AIRLINE’S operation on the Premises (e.g. pavement deicers, rubber removal chemicals, detergents, etc.), AIRLINE use shall be limited to those products which are approved by the Minnesota Pollution Control Agency (MPCA).

c. Tanks

AIRLINE shall own and hold title to any aboveground storage tanks installed at any time by AIRLINE at the Premises, and shall apply for and obtain in AIRLINE's or any affiliated company's name any permits required by applicable laws in connection with such tanks. Installation of any underground tanks by AIRLINE shall be prohibited, and any installation of any above ground tanks shall require the written approval of MAC. AIRLINE and MAC acknowledge and agree that any tanks installed on the Premises by AIRLINE during the Term of this Agreement will remain under the ownership and control of AIRLINE until such tanks are removed from the Premises by AIRLINE or AIRLINE no longer leases the premises containing such tanks, whichever is earlier. With respect to tanks closed after January 1, 2019, at the expiration or termination of this Agreement, AIRLINE is required to remove all tanks which it installed within the Premises in accordance with applicable Environmental Laws and provide information to MAC which adequately demonstrates that the tanks have been closed and removed in accordance with applicable Environmental Laws; provided, however, that in the event AIRLINE demonstrates to the reasonable satisfaction of MAC that removal of any such tank is impractical, infeasible or unreasonably costly relative to the benefits of removal, such tank may be closed in place in accordance with applicable Environmental Laws. Provided further, that AIRLINE's obligation to remove or close any tank under this subsection may be waived upon written consent from MAC, which consent may be withheld, conditioned or delayed in its sole yet reasonable discretion. Should a release from any tank installed or operated by AIRLINE be discovered, AIRLINE shall be required to conduct all remediation or corrective action required to bring the Premises into compliance with applicable Environmental Laws or as required pursuant to Section X.D.1 above.

d. Miscellaneous Environmental Operating Conditions

AIRLINE agrees to take steps to implement, maintain and comply with the then-applicable MPCA approved plans or procedures including the Integrated Spill Plan, Recovered Fuels Plan, Oil/Water Separator Plan, and any required procedures as required by the then-applicable MPCA AST program or other MPCA regulations.

**XI. ASSIGNMENT, SUBLETTING, AND GROUND HANDLING**

**A. ADVANCE APPROVAL**

Except as provided in this Article, and except with respect to arrangements in effect on the date of execution of this Agreement for which the consent of MAC has previously been obtained, AIRLINE shall have no right to assign or sublease this Agreement, without the prior written consent of MAC, which rights of consent are granted to MAC by MAC Ordinance No. 58 §11(a), and which rights are absolute and expressly reserved to the MAC hereby.

1. AIRLINE, when requesting an approval of an assignment or sublease under this Article, shall include with its request a copy of the proposed agreement, if prepared, or a detailed summary of the material terms and conditions to be contained in such agreement. Any proposed agreement or detailed summary thereof shall provide the following information:
  - a. The Premises to be assigned, sublet or used;
  - b. The terms;
  - c. If a sublease, the rentals and fees to be charged; and
  - d. All material terms and conditions of the assignment or sublease that MAC may reasonably require.

If the agreement is subsequently executed, AIRLINE shall submit a fully executed copy of such agreement to MAC promptly upon the execution thereof.

2. MAC shall have the right to examine the terms of any agreement or arrangement submitted to it for approval pursuant to this Article and determine whether such agreement or arrangement is most appropriately characterized as an assignment or sublease, regardless of AIRLINE's characterization of such agreement or arrangement.
3. If AIRLINE fails to obtain written approval from MAC prior to the effective date of any such assignment or sublease, MAC, in addition to the rights and remedies set forth in Article XIV, shall have the right to refuse to recognize such agreement, and the assignee or sublessee Airline shall acquire no interest in this Agreement or any rights to use the Premises.

**B. ASSIGNMENT**

1. AIRLINE shall not assign this Agreement, in whole or part, without the advance written approval of MAC.
2. It shall not be unreasonable for MAC to disapprove or condition an assignment of the Agreement under any or all of the following circumstances, among others:
  - a. MAC determines that the proposed assignee is not substantially as creditworthy as the AIRLINE, unless AIRLINE agrees to guarantee the obligations of the proposed assignee.
  - b. The proposed assignment is either (1) for less than the entire Premises or (2) for less than the remainder of the Term, or both (1) and (2).



- c. The proposed assignment does not require the assignee to accept and comply with all provisions of the Agreement, including but not limited to accepting Signatory Airline status.
3. Notwithstanding the foregoing, this Section shall not be interpreted to preclude the assignment of this Agreement in whole and AIRLINE's rights and obligations hereunder to a parent, subsidiary, or merged company; provided that, such parent, subsidiary, or merged company conducts an Air Transportation Business at the Airport and that such parent, subsidiary, or merged company assumes all rights and obligations hereunder. Written notice of such assumption shall be provided by the parent, subsidiary, or merged company prior to the effective date of such assignment.

**C. SUBLEASE AGREEMENT**

1. AIRLINE shall not sublet its Premises, except to an Affiliated Airline or Alliance Partner, in whole or part, without the advance written approval of MAC. AIRLINE may sublet or license the Premises to an Affiliated Airline or an Alliance Partner without the advance written approval of MAC.
2. It shall not be unreasonable for MAC to disapprove or condition a sublease of AIRLINE's Premises if the proposed sublessee is not an Air Transportation Company and MAC reasonably concludes that the space can be used by another Air Transportation Company.
3. AIRLINE may, subject to a sublease approved by MAC, charge a sublessee of its Premises:
  - a. A reasonable charge for any services provided by AIRLINE;
  - b. A reasonable charge for any AIRLINE-owned property provided by AIRLINE or actual costs other than rentals incurred by AIRLINE; and
  - c. Reasonable rentals not to exceed one hundred fifteen percent (115%) of AIRLINE's rentals for such portion of the Premises.
4. AIRLINE shall remain fully and primarily liable during the Term of this Agreement for the payment of all rents, fees, and charges due and payable to MAC for the Premises that are subject to a sublease agreement, and the AIRLINE shall remain fully responsible for the performance of all of its other obligations hereunder, unless otherwise agreed to by MAC.

**D. GROUND HANDLING AGREEMENT**

1. AIRLINE shall be entitled to provide Ground Handling services to other Airlines in Terminal 1 and Terminal 2 and Terminal Ramp, subject to MAC's Rules and Regulations and Ordinances and Section III.C of this Agreement, if applicable.
2. AIRLINE shall not contract with other companies, excluding Signatory Airlines for Ground Handling services in Terminal 1 and Terminal 2 and Terminal Ramp for AIRLINE's aircraft, without advance written approval of MAC, which shall not be unreasonably withheld, conditioned, or delayed so long as such Ground Handling service provider has executed a permit or other agreement reasonably required by MAC to provide such services at the Airport.
3. AIRLINE shall remain fully and primarily liable during the Term of this Agreement for the payment of all rents, fees, and charges due and payable to MAC for the Premises that are subject to a Ground Handling agreement, and the AIRLINE shall remain fully responsible for the performance of all of its other obligations hereunder, unless otherwise agreed to by MAC.
4. MAC reserves the right to charge third parties other than Airlines a reasonable Ground Handling fee not to exceed 5% of gross receipts and a reasonable annual administrative fee, and require such third party to enter into a license agreement with MAC for their right to provide Ground Handling services to AIRLINE or Airlines. Notwithstanding the previous sentence, a third party that is a wholly owned subsidiary of AIRLINE, shall not be charged the Ground Handling fee for Ground Handling services provided to AIRLINE, but shall still be charged the annual administrative fee and the Ground Handling fee for Ground Handling services provided to other Airlines.
5. Ground Handling rights outside Terminal 1 and Terminal 2 will be addressed in separate agreements between MAC and the affected airlines.

**E. BANKRUPTCY**

Any receiver, trustee, custodian, or other similar official appointed pursuant to any proceeding relating to bankruptcy, reorganization, or other relief as set forth in Section XIV.A.8., herein shall agree to:

1. Perform promptly every obligation of AIRLINE under this Agreement until this Agreement is either assumed or rejected under the Federal Bankruptcy Code;
2. Pay on a current basis all rents, fees and charges set forth in this Agreement;
3. Reject or assume this Agreement within sixty (60) days of filing a petition under the Federal Bankruptcy Code;

4. Cure or provide adequate assurance of a prompt cure of any default of the AIRLINE under this Agreement;
5. Provide to MAC such adequate assurance of future performance under this Agreement as may be requested by MAC, including the procurement of a bond from a financially reputable surety covering any costs or damages incurred by MAC in the event that MAC, within five (5) years after assumption or assignment of this Agreement, exercises its rights to relet the Premises.
6. In addition to the other rights of MAC hereunder, to the extent necessary, to effect its rights under Section VI.J of the Lease in any future bankruptcy involving AIRLINE pursuant to the doctrines of setoff and/or recoupment.

## **XII. DISPUTE RESOLUTION**

Except in respect to proceedings in unlawful detainer, in the event of any dispute, claim or controversy arising out of or relating to this Agreement or the breach, termination, enforcement, interpretation or validity thereof, the parties shall use their best efforts to settle the dispute by negotiation. If MAC and AIRLINE are still unable to resolve their dispute, each agrees to consider submitting such dispute to mediation or other acceptable form of alternate dispute resolution.

## **XIII. [INTENTIONALLY OMITTED]**

## **XIV. EVENTS OF DEFAULT; REMEDIES**

### **A. EVENTS OF DEFAULT**

The occurrence and continuation of any one or more of the following shall constitute an event of default:

1. AIRLINE fails to make payment in full when due of any rents, fees, charges or any other amount payable hereunder within five business days after its receipt of written notice thereof from MAC;
2. AIRLINE shall fail to make any PFC remittance to MAC in a timely fashion and does not remedy such failure within five business days after its receipt of written notice thereof from MAC, or shall fail to timely comply with its PFC reporting requirements to the MAC and does not remedy such failure five business days after its receipt of written notice thereof from MAC, or any other entity, in connection with PFCs collected on behalf of MAC;
3. AIRLINE fails to submit a Monthly Activity Report to MAC on or before the 10th day of each month and does not submit such report within five business days after notice of such failure from MAC;

AIRLINE shall make or permit any unauthorized assignment or transfer of this Agreement, or any interest herein, or of the right to use or possession of the Premises, or any part thereof, and AIRLINE does not remedy such situation five business days after its receipt of written notice thereof from MAC;

4. Any insurance required by the terms hereof shall at any time not be in full force or effect;
5. Failure of AIRLINE to perform, comply with, or observe, in any material respect, any other term, condition or covenant of this Agreement not identified elsewhere in Section A of this Article within thirty (30) days after receipt of notice from MAC of such failure, or for such longer period of time as may be reasonably necessary to cure the event of default, but only for such longer period if: (a) AIRLINE is reasonably capable of curing the event of default and (b) AIRLINE promptly and continuously undertakes to cure and diligently pursues the curing of the event of default at all times until such event of default is cured;
6. Any representation or warranty of a material fact made by AIRLINE herein or in any certificate or statement furnished to the MAC pursuant to or in connection with this Agreement proves untrue in any material and adverse respect as of the date of issuance or making thereof;
7. (a) AIRLINE shall commence any case, proceeding or other action (i) under any existing or future law of any jurisdiction, domestic or foreign, relating to bankruptcy, insolvency, reorganization or relief of debtors, seeking to have an order for relief entered with respect to AIRLINE, or seeking to adjudicate AIRLINE a bankrupt or insolvent, or seeking reorganization, arrangement, adjustment, liquidation, dissolution, composition or other relief with respect to AIRLINE or any of its debts, or (ii) seeking appointment of a receiver, trustee, custodian or other similar official for AIRLINE or for all or any substantial part of any of its property; or (b) AIRLINE shall make a general assignment for the benefit of its creditors; or (c) there shall be commenced against AIRLINE any case, proceeding or other action of nature referred to in clause (a) above or seeking issuance of a warrant of attachment, execution, distraint or similar process against all or any substantial part of any of its property, which case, proceeding or other action results in the entry of an order for relief or remains undismissed, unvacated, undischarged and unbonded for a period of sixty (60) days; or (d) AIRLINE shall take any action consenting to or approving of any of the acts set forth in clause (a) or (b) above; or (e) AIRLINE shall generally not, or shall be unable to, pay its debts as they become due or shall admit in writing its inability generally to pay its debts as they become due;
8. Any unappealable money judgment, writ or warrant of attachment or similar process, or any combination thereof, that may reasonably materially and adversely impact AIRLINE's operations hereunder and involves an amount in excess of \$50,000,000 shall be entered or filed against the AIRLINE or any of its assets and shall remain undischarged, unvacated, unbonded and unstayed for a period of sixty (60) days or in any event later than five (5) days prior to the date of any proposed sale or execution thereunder;

9. Any act occurs that deprives AIRLINE permanently of any material right, power or privilege necessary for the conduct and operation of its Air Transportation Business; or
10. If AIRLINE ceases to provide scheduled air service at the Airport for a period of thirty (30) consecutive days or abandons or fails to use its Exclusive Use Space for a period of thirty (30) consecutive days, except when such cessation or abandonment is due to the default of MAC or the circumstances described in Section IX.B.

**B. REMEDIES**

If an event of default occurs hereunder, MAC, at its option, may at any time thereafter, do one or more of the following as MAC in its sole discretion shall elect, to the extent permitted by, and subject to compliance with any mandatory requirements of, applicable law then in effect:

1. Declare all rents, fees and other charges payable hereunder, whether currently or hereafter accruing, to be immediately due and payable;
2. Proceed by appropriate court action or actions, either at law or in equity, to enforce performance by AIRLINE of the applicable covenants and terms of this Agreement or to recover damages for the breach thereof;  
  
Enter and take possession of the Premises, (and remove and store at AIRLINE'S cost any property including aircraft owned by parties other than AIRLINE) and/or the rights of the AIRLINE hereunder without such re-entry terminating AIRLINE's obligations for the full Term hereof, which remedy shall be in addition to all other remedies at law or in equity, including action for forcible entry and lawful detainer, for ejectment or for injunction;
3. Terminate all rights of AIRLINE under this Agreement (without terminating the continuing obligation of AIRLINE to fulfill its past and future obligation hereunder) and in such case AIRLINE further agrees to indemnify and hold harmless MAC against all loss in rents, fees, and charges and other damages which MAC shall incur by reason of such termination, including, without limitation, costs of restoring and repairing the Premises and putting the same in rentable condition, costs of reletting the Premises to another Airline (including without limitation AIRLINE improvement costs and related fees), loss or diminution of rents and other damage which MAC incurs by reason of such termination, and all reasonable attorneys' fees and expenses incurred in enforcing the terms of this Agreement;
4. In the event of any default hereunder, AIRLINE shall reimburse MAC for all reasonable fees and costs incurred by MAC, including reasonable attorneys' fees, relating to such default and/or the enforcement of MAC's rights hereunder; and

5. Apply all Contract Security granted by AIRLINE to any unpaid obligations of AIRLINE hereunder.

## **XV. TERMINATION**

### **A. TERMINATION BY MAC**

This Agreement may be terminated by MAC pursuant to the provisions of Article XIV above and as otherwise specified in this Agreement.

### **B. TERMINATION BY AIRLINE**

1. If MAC shall fail to perform, comply with, or observe, in any material respect, any term, condition or covenant of this Agreement within thirty (30) days after receipt of notice from AIRLINE of such failure, or for such longer period of time as may be reasonably necessary to cure the event of default but only for such longer period if: (a) MAC is reasonably capable of curing the event of default and (b) MAC promptly and continuously undertakes to cure and diligently pursues the curing of the event of default at all times until such event of default is cured, then AIRLINE, if not then in default beyond any applicable notice and cure period, may, without limiting any of its other rights and remedies against MAC, at its option cancel this Agreement and thereby terminate this Agreement.
2. It is further understood and agreed that, at any time when AIRLINE is not then in default, it may cancel this Agreement on sixty (60) days' notice in writing to MAC upon the happening of any one of the following events:
  - a. Issuance by any court of competent jurisdiction of an injunction in any way preventing or restraining the use of the Airport or any part thereof essential for AIRLINE's operations hereunder and the remaining in force of such injunction for a period of at least ninety (90) days. Inability of the AIRLINE to use the Airport or any part thereof essential for AIRLINE's operations hereunder for a period of not less than ninety (90) days because of fire, explosion, earthquake, or other casualty or acts of God or the public enemy, unless within sixty (60) days of the casualty, MAC gave AIRLINE written notice of its intention to repair or reconstruct, as provided in Section IX.A. herein.
  - b. The lawful assumption by the United States of America or any authorized agency thereof of the operation, control, or use of the Airport and the facilities thereon or any substantial part or parts thereof, in such manner as substantially to restrict AIRLINE for a period of not less than ninety (90) days from operating thereon for the carrying of passengers, cargo, express, property, and United States mail.
  - c. Termination or the suspension or substantial modification for a period of not less than ninety (90) days of the operating authority of the AIRLINE to serve the Minneapolis-St. Paul metropolitan area through the Airport by final order of the DOT or other governmental agency, federal or state, having jurisdiction over the AIRLINE.

3. If any of the foregoing continues for a period of less than ninety (90) days, AIRLINE shall have the right upon written notice to MAC to abatement of rents, fees and charges to the extent and for the period that AIRLINE is unable to carry on its operations hereunder.

**C. TERMINATION BY GOVERNMENT TAKING**

If the Premises, or any portion thereof, shall be taken by governmental authority through exercise of its power of eminent domain or other authority justifying such taking, the Agreement shall terminate with respect to such portion of the Premises and the rents, fees and charges in respect to the Premises shall cease as of the date possession is taken by the taking authority, and MAC shall be entitled to all damages payable by reason of taking, subject to the claim of AIRLINE for the value of its leasehold, which claim or claims as to validity and amount shall be a matter for determination between AIRLINE and MAC, and if AIRLINE and MAC cannot reach a determination, then by the court having jurisdiction of such proceeding, provided that nothing herein contained shall preclude AIRLINE from asserting any claims or rights it may have against such governmental authority as to its separate property, leasehold improvements, and trade fixtures.

**XVI. GENERAL PROVISIONS**

**A. INTERPRETATION**

Nothing herein shall be construed or interpreted in any manner whatsoever as limiting, relinquishing or waiving MAC's right of control over the operation of the Airport, and it is understood and agreed that this Agreement is entered into in recognition of the aforesaid rights and functions of MAC. Subject to the foregoing, this Agreement and the rights of the parties hereunder shall be interpreted in the light of the following:

1. Severability

If any covenant, condition or provision herein is held to be invalid, illegal, or unenforceable by any court of competent jurisdiction, such covenant, condition or provision shall be deemed amended to conform to applicable laws so as to be valid or enforceable or, if it cannot be so amended without materially altering the intention of the parties, it shall be stricken. If stricken, all other covenants, conditions and provisions of this Agreement shall remain in full force and effect provided that the striking of such covenants, conditions or provisions does not materially prejudice either MAC or AIRLINE in either of their respective rights and obligations contained in the valid covenants, conditions or provisions of this Agreement.

2. No Oral Agreements

All agreements related to the conditions, agreements, and understandings between the parties concerning the use and occupancy of the Airfield, Terminal Apron, Terminal 1, and Terminal 2 shall be in writing, duly authorized and executed by the respective parties and may not be amended, changed, modified, or altered without the written consent of the parties hereto. Nothing herein shall preclude the adoption and enforcement of MAC Rules and Regulations and Ordinances and MAC Policies including but not limited to, Ordinance 115, MSP Field Rules, and Terminal 2 Operating Procedures.

**B. COMPLIANCE WITH LAW**

1. AIRLINE shall not use the Airport or any part thereof, or knowingly permit the same to be used by any of its employees, officers, agents, subtenants, invitees, or licensees for any illegal purposes. AIRLINE shall, at all times during the Term of this Agreement, comply with all applicable regulations, ordinances, and laws of any Municipal, County, or State government or of the U.S. Government, and of any political division or subdivision or agency, authority, or commission thereof which may have jurisdiction to pass laws or ordinances or to make and enforce rules or regulations with respect to the uses hereunder of the Premises (and, to the extent not in conflict with the foregoing, MAC's Rules and Regulations and Ordinances). AIRLINE agrees to indemnify, defend, and hold MAC harmless from any and all costs incurred by MAC with respect to AIRLINE's failure to comply with any applicable lawful regulations, ordinances, and laws of any Municipal, County, or State government or of the U.S. Government, and of any political division or subdivision or agency, authority, or commission thereof which may have jurisdiction to pass laws or ordinances or to make and enforce rules or regulations with respect to the uses hereunder of the Premises (and, to the extent not in conflict with the foregoing, MAC's Rules and Regulations and Ordinances) as and to the extent required under the general indemnity set forth in Section X.A. hereof. Notwithstanding the foregoing, nothing in this Agreement is intended to waive AIRLINE'S right to challenge the authority or legality of a law, ordinance or regulation.
2. At all times during the Term of this Agreement, AIRLINE shall, in connection with its activities and operations at the Airport:
  - a. Comply with and conform to all present and future applicable lawful statutes and ordinances, and regulations promulgated thereunder, of all Federal, State, and other government bodies of competent jurisdiction that apply to or affect, either directly or indirectly, AIRLINE or AIRLINE's operations and activities under this Agreement. AIRLINE shall comply with all applicable provisions of the Americans with Disabilities Act of 1990, 42 U.S.C. Section 12101 and federal regulations promulgated thereunder 28 C.F.R. parts 35, 36, and 37.
  - b. Make, at its own expense, all non-structural improvements, repairs, and alterations to its Exclusive Use Space and Preferential Use Space (subject to prior written approval of MAC), equipment, and personal property that are required to comply with or conform to any of such statutes and ordinances.



- c. Reimburse MAC for AIRLINE's proportionate share of all non-structural improvements, repairs, and alterations to its Joint Use Space that are required to comply with or conform to any of such statutes and ordinances.
- d. At all times during the Term of this Agreement, AIRLINE shall be an independent contractor.
- e. AIRLINE shall be solely and fully responsible for ensuring that Airline's operations, wherever they may occur at the Airport, and any improvements made by AIRLINE pursuant to this Agreement, shall comply with the applicable provisions of Title II and Title III of the Americans with Disabilities Act, 42 U.S.C. §§ 12101 et seq., as amended from time to time ("ADA"), and the Air Carrier Access Act, 49 U.S.C. § 41705, as amended from time to time ("ACAA"), including without limitation any obligation to provide boarding and deplaning assistance at the Airport. In the event of a violation of or non-compliance with the applicable provisions of Title II or III of the ADA or the ACAA, AIRLINE shall develop a work plan to correct such violation or non-compliance. MAC's approval of or acceptance of any aspect of AIRLINE's activities under this Agreement shall not be deemed or construed in any way as a representation that such item, activity or practice complies with the ADA or the ACAA. MAC shall comply with the ADA and the ACAA as applicable to any facilities constructed by MAC and any improvements made by MAC at the Airport as well as any operations, services, or procedures offered or controlled by MAC.

3. Compliance with Environmental Laws

AIRLINE shall keep and maintain and shall conduct its operations on the Airport in connection with this Agreement, in full compliance with all applicable Environmental Laws. AIRLINE shall further ensure that its employees, agents, contractors and subcontractors occupying or present on the Airport in connection with this Agreement, and any other invitees or persons conducting any activities on the Airport under the control of AIRLINE in connection with this Agreement comply with all applicable Environmental Laws. By virtue of its operational control of the Premises, AIRLINE shall be fully responsible for obtaining in AIRLINE'S name all necessary permits or other approvals under the Environmental Laws and shall have full responsibility for signing and submitting any necessary applications, forms, documentation, notifications or certifications relating thereto. Upon request of MAC, AIRLINE shall provide copies to MAC of any such applications, forms, documents, notifications or certifications.

**C. ADDITIONAL FEDERAL REQUIREMENTS**

1. General Civil Rights Provisions

AIRLINE agrees to comply with pertinent statutes, Executive Orders and such rules as are promulgated to ensure that no person shall, on the grounds of race, creed, color, national origin, sex, age, or disability be excluded from participating in any activity conducted with or benefiting from Federal assistance. If AIRLINE transfers its obligation to another, the transferee is obligated in the same manner as AIRLINE.

This provision obligates AIRLINE for the period during which the property is owned, used or possessed by AIRLINE and the Airport remains obligated to the Federal Aviation Administration. This provision is in addition to that required by Title VI of the Civil Rights Act of 1964.

2. Compliance with Nondiscrimination Requirements

During the performance of this Agreement, AIRLINE, for itself, its assignees, and successors in interest (hereinafter referred to as the "AIRLINE") agrees as follows:

- a. Compliance with Regulations: AIRLINE (hereinafter includes consultants) will comply with the Title VI List of Pertinent Nondiscrimination Acts and Authorities, as they may be amended from time to time, which are herein incorporated by reference and made a part of this Agreement.
- b. Nondiscrimination: AIRLINE, with regard to the work performed by it during the Agreement, will not discriminate on the grounds of race, color, or national origin in the selection and retention of subcontractors, including procurements of materials and leases of equipment. AIRLINE will not participate directly or indirectly in the discrimination prohibited by the Nondiscrimination Acts and Authorities, including employment practices when the Agreement covers any activity, project, or program set forth in Appendix B of 49 CFR part 21.
- c. Solicitations for Subcontracts, Including Procurements of Materials and Equipment: In all solicitations, either by competitive bidding, or negotiation made by AIRLINE for work to be performed under a subcontract, including procurements of materials, or leases of equipment, each potential subcontractor or supplier will be notified by AIRLINE of AIRLINE'S obligations under this Agreement and the Nondiscrimination Acts and Authorities on the grounds of race, color, or national origin.
- d. Information and Reports: AIRLINE will provide all information and reports required by the Acts, the Regulations, and directives issued pursuant thereto and will permit access to its books, records, accounts, other sources of information, and its facilities as may be determined by MAC or the Federal Aviation Administration to be pertinent to ascertain compliance with such Nondiscrimination Acts and Authorities and instructions. Where any information required of AIRLINE is in the exclusive possession of another who fails or refuses to furnish the information, AIRLINE will so certify to MAC or the Federal Aviation Administration, as appropriate, and will set forth what efforts it has made to obtain the information.

- e. Sanctions for Noncompliance: In the event of AIRLINE'S noncompliance with the nondiscrimination provisions of this Agreement, MAC will impose such contract sanctions as it or the Federal Aviation Administration may determine to be appropriate, including, but not limited to:
    - 1) Withholding payments to AIRLINE under the Agreement until AIRLINE complies; and/or
    - 2) Cancelling, terminating, or suspending the Agreement, in whole or in part.
  - f. Incorporation of Provisions: AIRLINE will include the provisions of subparagraphs (a) through (f) in every subcontract, including procurements of materials and leases of equipment, unless exempt by the Acts, the Regulations and directives issued pursuant thereto. AIRLINE will take action with respect to any subcontract or procurement as the sponsor or the Federal Aviation Administration may direct as a means of enforcing such provisions including sanctions for noncompliance. Provided, that if AIRLINE becomes involved in, or is threatened with litigation by a subcontractor, or supplier because of such direction, AIRLINE may request MAC to enter into any litigation to protect the interests of MAC. In addition, AIRLINE may request the United States to enter into the litigation to protect the interests of the United States.
3. Title VI Clauses for Transfer of Real Property Acquired or Improved Under the Airport Improvement Program
- a. AIRLINE, for itself, its heirs, personal representatives, successors in interest, and assigns, as a part of the consideration hereof, does hereby covenant and agree as a covenant running with the land that:
    - 1) In the event facilities are constructed, maintained, or otherwise operated on the property described in this Agreement for a purpose for which a Federal Aviation Administration activity, facility, or program is extended or for another purpose involving the provision of similar services or benefits, AIRLINE will maintain and operate such facilities and services in compliance with all requirements imposed by the Nondiscrimination Acts and Regulations listed in the Pertinent List of Nondiscrimination Authorities (as may be amended) such that no person on the grounds of race, color, or national origin, will be excluded from participation in, denied the benefits of, or be otherwise subjected to discrimination in the use of said facilities.
  - b. With respect to this Agreement, in the event of breach of any of the above Nondiscrimination covenants, MAC will have the right to terminate the Agreement and to enter, re-enter, and repossess said lands and facilities thereon, and hold the same as if the (lease, license, permit, etc.) had never been made or issued.

4. Clauses for Construction/Use/Access to Real Property Acquired Under the Activity, Facility or Program
  - a. AIRLINE, for itself, its heirs, personal representatives, successors in interest, and assigns, as a part of the consideration hereof, does hereby covenant and agree, as a covenant running with the land, that (1) no person on the ground of race, color, or national origin, will be excluded from participation in, denied the benefits of, or be otherwise subjected to discrimination in the use of said facilities, (2) that in the construction of any improvements on, over, or under such land, and the furnishing of services thereon, no person on the ground of race, color, or national origin, will be excluded from participation in, denied the benefits of, or otherwise be subjected to discrimination, (3) that the lessee will use the premises in compliance with all other requirements imposed by or pursuant to the List of Nondiscrimination Acts and Authorities.
  - b. With respect to this Agreement, in the event of breach of any of the above nondiscrimination covenants, MAC will have the right to terminate the lease and to enter or re-enter and repossess said land and the facilities thereon, and hold the same as if said Agreement had never been made or issued.

5. Title VI List of Pertinent Nondiscrimination Acts and Authorities

During the performance of this Agreement, AIRLINE, for itself, its assignees, and successors in interest (hereinafter referred to as the "AIRLINE") agrees to comply with the following nondiscrimination statutes and authorities; including but not limited to:

- Title VI of the Civil Rights Act of 1964 (42 USC § 2000d *et seq.*, 78 stat. 252) (prohibits discrimination on the basis of race, color, national origin);
- 49 CFR part 21 (Non-discrimination in Federally-assisted programs of the Department of Transportation—Effectuation of Title VI of the Civil Rights Act of 1964);
- The Uniform Relocation Assistance and Real Property Acquisition Policies Act of 1970, (42 USC § 4601) (prohibits unfair treatment of persons displaced or whose property has been acquired because of Federal or Federal-aid programs and projects);
- Section 504 of the Rehabilitation Act of 1973 (29 USC § 794 *et seq.*), as amended (prohibits discrimination on the basis of disability); and 49 CFR part 27;
- The Age Discrimination Act of 1975, as amended (42 USC § 6101 *et seq.*) (prohibits discrimination on the basis of age);

- Airport and Airway Improvement Act of 1982 (49 USC § 471, Section 47123), as amended (prohibits discrimination based on race, creed, color, national origin, or sex);
  - The Civil Rights Restoration Act of 1987 (PL 100-209) (broadened the scope, coverage and applicability of Title VI of the Civil Rights Act of 1964, the Age Discrimination Act of 1975 and Section 504 of the Rehabilitation Act of 1973, by expanding the definition of the terms “programs or activities” to include all of the programs or activities of the Federal-aid recipients, sub-recipients and contractors, whether such programs or activities are Federally funded or not);
  - Titles II and III of the Americans with Disabilities Act of 1990, which prohibit discrimination on the basis of disability in the operation of public entities, public and private transportation systems, places of public accommodation, and certain testing entities (42 USC §§ 12131 – 12189) as implemented by U.S. Department of Transportation regulations at 49 CFR parts 37 and 38;
  - The Federal Aviation Administration’s Nondiscrimination statute (49 USC § 47123) (prohibits discrimination on the basis of race, color, national origin, and sex);
  - Executive Order 12898, Federal Actions to Address Environmental Justice in Minority Populations and Low-Income Populations, which ensures nondiscrimination against minority populations by discouraging programs, policies, and activities with disproportionately high and adverse human health or environmental effects on minority and low-income populations;
  - Executive Order 13166, Improving Access to Services for Persons with Limited English Proficiency, and resulting agency guidance, national origin discrimination includes discrimination because of limited English proficiency (LEP). To ensure compliance with Title VI, you must take reasonable steps to ensure that LEP persons have meaningful access to your programs (70 Fed. Reg. at 74087 to 74100);
  - Title IX of the Education Amendments of 1972, as amended, which prohibits you from discriminating because of sex in education programs or activities (20 USC 1681 et seq).
6. AIRLINE, by accepting this Agreement, agrees for itself and its successors and assigns that it will not make use of the Airport premises in any manner which might interfere with the landing and taking off of aircraft from the Airport or otherwise constitute a hazard. In the event the aforesaid covenant is breached, MAC reserves the right to enter upon the Airport premises and cause the abatement of such interference at the expense of AIRLINE.

7. AIRLINE, by accepting this Agreement, expressly agrees for itself and its successors and assigns that it will not erect nor permit the erection of any structure or object, nor permit the growth of any tree on the Airport premises, above the main sea level elevation that would exceed FAR Part 77 standards or elevations affecting the Airport navigable airspace. In the event the aforesaid covenants are breached, MAC reserves the right to enter upon the permitted premises and to remove the offending structure or object and cut the offending tree, all of which shall be at the expense of AIRLINE.

**D. ECONOMIC NONDISCRIMINATION**

AIRLINE agrees to furnish service on a reasonable, and not unjustly discriminatory basis to all users thereof, and to charge reasonable, and not unjustly discriminatory prices for each unit or service, provided that AIRLINE may be allowed to make reasonable and nondiscriminatory discounts, rebates, or other similar types of price reductions to volume purchasers.

**E. GRANTING OF MORE FAVORABLE TERMS**

MAC covenants and agrees not to enter into any lease, contract, or agreement with any other Airline making use of the Airport with more favorable terms, rates or charges or which unjustly discriminates against AIRLINE's use of the Airport, unless the same rights, privileges, terms, rates, charges and concessions are concurrently and automatically made available to AIRLINE. Without limiting the generality thereof, the foregoing shall not be construed to limit the right of MAC to enter into agreement with any other Airline at varying terms, rates, and conditions for leasing hangars and ground areas.

**F. CONSENTS, APPROVALS, AND NOTICES**

1. Wherever in this Agreement the consent or approval of MAC or AIRLINE is required, such consent or approval shall mean the consent or approval of the Executive Director in writing on behalf of MAC and a representative designated by AIRLINE in writing on behalf of AIRLINE.
2. All notices required by this Agreement shall be in writing and shall be given by registered or certified mail by depositing the same in the U.S. mail in the continental United States, postage prepaid, return receipt requested, or by personal or courier delivery or by reputable overnight courier or by email with proof of delivery or receipt. Either party shall have the right, by giving written notice to the other, to change the address at which its notices are to be received. Notice shall be given to:

a. MAC:

Director of Commercial Management and Airline Affairs Metropolitan  
Airports Commission  
6040 28th Avenue South  
Minneapolis MN 55450

If by email, to the email address of the current Director of Commercial Management and Airline Affairs.

- b. AIRLINE:  
[as set forth below  
in AIRLINE's  
signature page hereto]  
If by email, to the email address of the employee designated by AIRLINE.
- c. If notice is given in another manner or place, it shall also be given at the place and in the manner specified above.
- d. The effective date of such notice, consent, or approval shall be the date of the receipt as shown by the U.S. Postal Service Return Receipt or the courier receipt, the email confirmation, or the date personal delivery is certified, unless provided otherwise in this Agreement.

**G. WAIVER**

- 1. Waiver of any provision of this Agreement by either party shall not be deemed binding unless such waiver is in writing, signed by the party making the waiver and addressed to the other party, nor shall any custom or practice which may evolve between the parties in the administration of the terms of this Agreement be construed to waive or lessen the right of either party to insist upon the performance of the other party in strict accordance with the terms of this Agreement.
- 2. Waiver by either party of breach of any covenant, condition, or agreement herein by the other party shall not operate as a waiver of any subsequent breach by such other party or release such other party from its obligation under the terms of the Agreement.

**H. APPLICABLE LAW AND FORUM SELECTION**

- 1. This Agreement shall be governed by and construed and enforced in accordance with the applicable laws of the State of Minnesota, and the Rules and Regulations and Ordinances of MAC as well as applicable federal law.
- 2. Subject to Article XII, any cause of action, claim, suit, demand, or other case, or controversy arising from or related to this Agreement shall only be brought in a state district court located in the county of Hennepin, Minnesota or in a federal district court located in Minnesota. The parties irrevocably admit themselves to, and consent to, the jurisdiction of either or both of said courts. The provisions of this Section shall survive the termination of this Agreement.

**I. SUCCESSORS**

All covenants, stipulations, and agreements in this Agreement shall extend to and bind the legal representatives, successors, and assigns of the respective parties hereto.

**J. INSPECTION**

1. MAC shall have the right, but not the obligation or duty, to inspect AIRLINE's operations at all reasonable times and upon reasonable prior written notice to AIRLINE, for any purpose connected with this Agreement, in the exercise of MAC's governmental functions, for the purpose of determining whether AIRLINE is fulfilling the obligations imposed on it under the provisions of this Agreement.
2. If inspection reveals that AIRLINE is not fulfilling such obligations or any thereof, and MAC has sent AIRLINE written notice to that effect, and AIRLINE has not within thirty (30) days proceeded to the fulfillment thereof, MAC may proceed to do the work necessary to such fulfillment, and AIRLINE shall reimburse MAC in the amount of the cost thereof plus a 15 percent administrative charge.
3. The failure of MAC to inspect or monitor or give AIRLINE notice of a default or a notice of a hazardous or unsafe condition with respect to AIRLINE's operations under this Agreement shall not release AIRLINE from its liability to perform its obligations under this Agreement or impose any liability on MAC.
4. AIRLINE shall have the right to inspect the Airport or any part thereof at any reasonable time, upon request to the Executive Director and the granting of such request by the Executive Director, such request not to be unreasonably denied, and the Executive Director or the Executive Director's representative shall accompany AIRLINE's representative on any and all inspections.

**K. QUIET ENJOYMENT**

So long as AIRLINE is not in default in its obligations hereunder, MAC covenants and agrees that AIRLINE shall have, hold and enjoy peaceful and uninterrupted possession of all of the Premises and of its rights to operate in, to and from the Airport as hereby granted.

**L. NON-LIABILITY OF AGENTS AND EMPLOYEES**

1. No member, officer, agent, director, or employee of MAC or AIRLINE shall be charged personally or held contractually liable by or to the other party under any term or provision of this Agreement or because of any breach thereof or because of its or their execution or attempted execution.



2. AIRLINE expressly agrees that MAC shall not be liable to AIRLINE, its contractors, agents, officers, employees, passengers, or invitees for personal injury or for any loss or damage to real or personal property occasioned by flood, fire, earthquake, lightning, windstorm, hail, explosion, riot, strike, civil commotion, aircraft, smoke, vandalism, malicious mischief, or acts of civil authority, or other casualty except to the extent caused by the negligence or willful misconduct of MAC, its contractors, subcontractors, agents or any of their employees or officers.
3. MAC expressly agrees that AIRLINE shall not be liable to MAC, its contractors, agents, officers, employees, or invitees for personal injury or for any loss or damage to real or personal property occasioned by flood, fire, earthquake, lightning, windstorm, hail, explosion, riot, strike, civil commotion, aircraft, smoke, vandalism, malicious mischief, or acts of civil authority, or other casualty except to the extent caused by the negligence or willful misconduct of AIRLINE, its contractors, subcontractors, agents or any of their employees or officers.
4. The provisions of this Section shall survive the termination of this Agreement.

**M. NO PARTNERSHIP OR AGENCY**

Nothing contained in this Agreement is intended or shall be construed in any respect to create or establish any relationship other than that of lessor and lessee, and nothing herein shall be construed to establish any partnership, joint venture or association or to make AIRLINE the general representative or agent of MAC for any purpose whatsoever.

**N. SECURITY**

In conjunction with AIRLINE's operations at Airport, reasonable access shall be made available for both persons and vehicles to AIRLINE's aircraft parked in designated parking areas via Terminal 1 or Terminal 2 doors, field access gates, passenger loading bridges, and the ramp gates to the SIDA, AOA, or other defined security area. In order to maintain the security of restricted areas on Airport, AIRLINE will be responsible for the control of persons and vehicles entering the SIDA via the ramp gates to and from AIRLINE's aircraft. AIRLINE agrees to implement and maintain security measures with respect to access control to and from AIRLINE's aircraft and with respect to the use of the SIDA, as required by federal regulations. Such security measures shall be reduced to writing and be provided to the Airport Security Coordinator. AIRLINE agrees to implement and maintain, as a minimum, the following security measures concerning access control to and from the SIDA:

1. During all hours, access points to the SIDA shall be secured and locked.
2. AIRLINE and its agents shall challenge any persons not recognized as being authorized to have access to the SIDA from AIRLINE's operations.
3. AIRLINE and its agents shall restrict the activities of its employees who are authorized to be in the SIDA to that portion of the SIDA in which AIRLINE is authorized to operate.

4. AIRLINE and its agents are responsible for ensuring that personnel are trained in the security procedures described in this Agreement and in all other security procedures, Rules and Regulations and Ordinances developed by MAC. MAC may require attendance at courses conducted by MAC.
5. AIRLINE and its agents shall not allow any unescorted person into the SIDA unless that person has a valid Airport identification badge. Identification badges shall not be considered valid unless the color code of the badge corresponds with the location in which such person may enter, as designated by MAC. People who do not have valid identification badges to be present on the SIDA shall be escorted at all times they are present on the SIDA by a person with a valid identification badge and valid escort endorsement. Issuance of AOA SIDA identification badges shall be made only by MAC and shall be at the sole discretion of MAC. Airport identification badges shall be denied to people not meeting security requirements.
6. AIRLINE and its agents shall abide by the Airport's security program and comply with applicable security procedures including, but not limited to, the wearing of security identification badges by AIRLINE's and its agents' personnel and clearly identifying each of AIRLINE's vehicles by placing AIRLINE's company or agent's name on each vehicle, and fully comply with any vehicle identification or licensing system adopted by MAC.
7. AIRLINE and its agents shall immediately notify the Airport Police of any suspicious activities observed in or about the SIDA.
8. Any unresolved questions concerning Airport security shall be directed to the Airport Security Coordinator.
9. AIRLINE further agrees to reimburse MAC for any penalties or fines levied against MAC by the FAA, Transportation Security Administration, or Customs and Border Patrol due to AIRLINE's or its agents' failure to abide by any applicable security measures.
10. The Airport Security Coordinator or his or her designated alternate will periodically evaluate compliance with this Section. Failure of AIRLINE to fully comply with the procedures set forth in this Section shall be sufficient grounds for MAC to immediately take any and all necessary corrective measures until security that is acceptable to MAC is restored. AIRLINE shall pay any costs of such corrective measures, plus an administrative fee of fifteen percent (15%) of such costs.
11. AIRLINE must immediately return each MAC-issued security identification badge to the airport badging office upon expiration of badge or upon termination of badgeholder's employment or contract. Further, AIRLINE must promptly report any loss or theft of an individual's MAC-issued security identification, the termination of any badgeholder whose security identification is not recovered; or the suspension of any badgeholder.

12. AIRLINE must comply within established timelines with any security audits conducted by the MAC including audits of airport-issued security badges.
13. AIRLINE and AIRLINE contractors must comply with the applicable provisions of MAC Ordinance 117 (or as amended).

**O. SUBORDINATION TO AGREEMENTS WITH THE U.S. GOVERNMENT**

This Agreement shall be subordinate and subject to the terms of any existing or future agreement between MAC and the United States, relative to the development, operation, or maintenance of the Airport, including but not limited to “Sponsor’s Grant Assurances” or like agreement that has been or may be furnished by MAC to the United States of America, its boards, commissions, or agencies, including without limitation the FAA, or any other agreement that is required by applicable laws as a condition precedent to receiving Federal financial assistance for development of the Airport and other Airport programs and activities. In the event that the FAA or its successors require any modifications or changes in this Agreement as a condition precedent to the granting of funds for the further improvement of the Airport or otherwise complying with the MAC’s assurances or like agreements, AIRLINE shall not withhold its consent to such amendments, modifications, revisions, supplements or deletions of any of the terms, conditions or requirements of this Agreement as may reasonably be required to obtain such funds. MAC agrees to provide AIRLINE with advance written notice of any provisions that would adversely modify the material terms of this Agreement.

This Agreement and all the provisions hereof shall be subject to whatever right the United States Government now has or in the future may acquire affecting the control, operation, regulation, and taking over of said Airport or the exclusive or non-exclusive use of the Airport by the United States during the time of war or national emergency.

**P. PFC ACT AND ASSURANCES**

1. Notwithstanding anything to the contrary in this Agreement, no provision of this Agreement shall impair the authority of MAC to impose a Passenger Facility Charge or to use the Passenger Facility Charge revenue as provided in the Aviation Safety and Capacity Expansion Act of 1990, 49 U.S.C. § 40117 (the “PFC Act”).
2. AIRLINE acknowledges that MAC has given to the United States of America, acting by and through the FAA, certain assurances set forth in the PFC Act and implementing regulations at 14 C.F.R. Part 158 (“PFC Assurances”), and AIRLINE agrees that this Agreement shall be subordinate and subject to the PFC Assurances.
3. In the event that the FAA or its successors require any modifications or changes in this Agreement as a condition precedent to the collection of PFCs or otherwise complying with the PFC Act, AIRLINE shall not withhold its consent to such amendments, modifications, revisions, supplements or deletions of any of the terms, conditions or requirements of this Agreement as may reasonably be required to collect PFCs or comply with the PFC Act. MAC agrees to provide AIRLINE with advance written notice of any provisions that would adversely modify material terms of this Agreement.

**Q. NO EXCLUSIVE RIGHT**

Nothing herein contained shall be deemed to grant to AIRLINE any exclusive right or privilege within the meaning of Section 308 of the Federal Aviation Act for the conduct of any activity on the Airport.

**R. CONCERNING DEPRECIATION AND INVESTMENT CREDIT**

Neither AIRLINE nor any successor of AIRLINE under this Agreement may claim depreciation or an investment credit under the Internal Revenue Code of 1986, as amended (the "Code"), with respect to the Premises. AIRLINE represents as an irrevocable election under Code Section 142(b)(1)(B) that it will not claim such depreciation or investment credit with respect to the Premises. MAC acknowledges this AIRLINE representation and election as part of its books and records.

**S. ATTORNEYS' FEES**

In any action brought by either party for the enforcement of any provisions of this Agreement, the party prevailing in said action shall be entitled to recover reasonable attorney's fees from the other party, unless the court shall otherwise award.

**T. SAVINGS**

MAC and AIRLINE acknowledge that they have thoroughly read this Agreement, including all exhibits thereto, and have sought and received whatever competent advice and counsel was necessary for them to form a full and complete understanding of all rights and obligations herein. MAC and AIRLINE further acknowledge that this Agreement is the result of extensive negotiations between them and that this Agreement shall not be construed against either party by reason of that party's preparation of all or part of this Agreement.

**U. MASTER TRUST INDENTURES**

1. Subordination of Facilities Construction Credits

The obligations of MAC under this Agreement, if any, which constitute Facilities Construction Credits or other forms of rental credits, are made subject and subordinate to the terms and payment provisions of the MAC revenue obligations issued pursuant to Minnesota Statutes, § 473.608, Subd. 12a., and the terms and provisions of Senior Trust Indenture which controls the issuance of such obligations, including MAC's obligation to meet its rate covenants under the Trust Indentures.

2. Airline Cooperation

- a. The AIRLINE agrees that it will cooperate with MAC, the underwriters and their counsel to satisfy any ongoing disclosure requirements necessary under applicable law in order to market the MAC revenue obligations, including provision of annual reports of AIRLINE or any parent.
- b. AIRLINE shall cooperate with MAC and the underwriters of MAC's revenue obligations so that the provisions of Rule 15c2-12 of the Securities Exchange Act of 1934, as amended, are complied with.

**V. AIRLINE SPECIFIC PROVISIONS**

Exhibit Z (if applicable) is hereby incorporated into this Agreement by reference.

IN WITNESS WHEREOF, the parties hereto have caused this Agreement to be executed by their duly authorized officers on the dates below.

**METROPOLITAN AIRPORTS COMMISSION**

By: /s/ Eric L. Johnson  
Eric L. Johnson

Director  
Its: Commercial Management & Airline Affairs

Date: April 23, 2019

**MN AIRLINES, LLC d/b/a SUN COUNTRY AIRLINES**

By: /s/ Jude Bricker  
Jude Bricker

Its: President & CEO

Date: \_\_\_\_\_

**Notice Address:**  
Sun Country Airlines  
Attn: General Counsel  
1300 Corporate Center Curve  
Eagan, MN 55121

STATE OF MINNESOTA )  
 )SS  
COUNTY OF HENNEPIN )

This instrument was acknowledged before me on the 23<sup>rd</sup> day of April, 2019, by Eric L. Johnson as the authorized representative of the Metropolitan Airports Commission.

(Notary Seal) /s/ Karen Racek \_\_\_\_\_  
Notary Public



STATE OF Minnesota )  
 )SS  
COUNTY OF Dakota )

This instrument was acknowledged before me on the 16<sup>th</sup> day of April, 2019, by Jude Bricker the President & CEO of MN Airlines, LLC.  
(Name) (Title) (Corporation)

(Notary Seal) /s/ Victoria Rene Palpant \_\_\_\_\_  
Notary Public

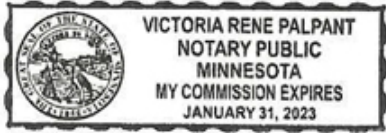





Airfield Cost  
Center

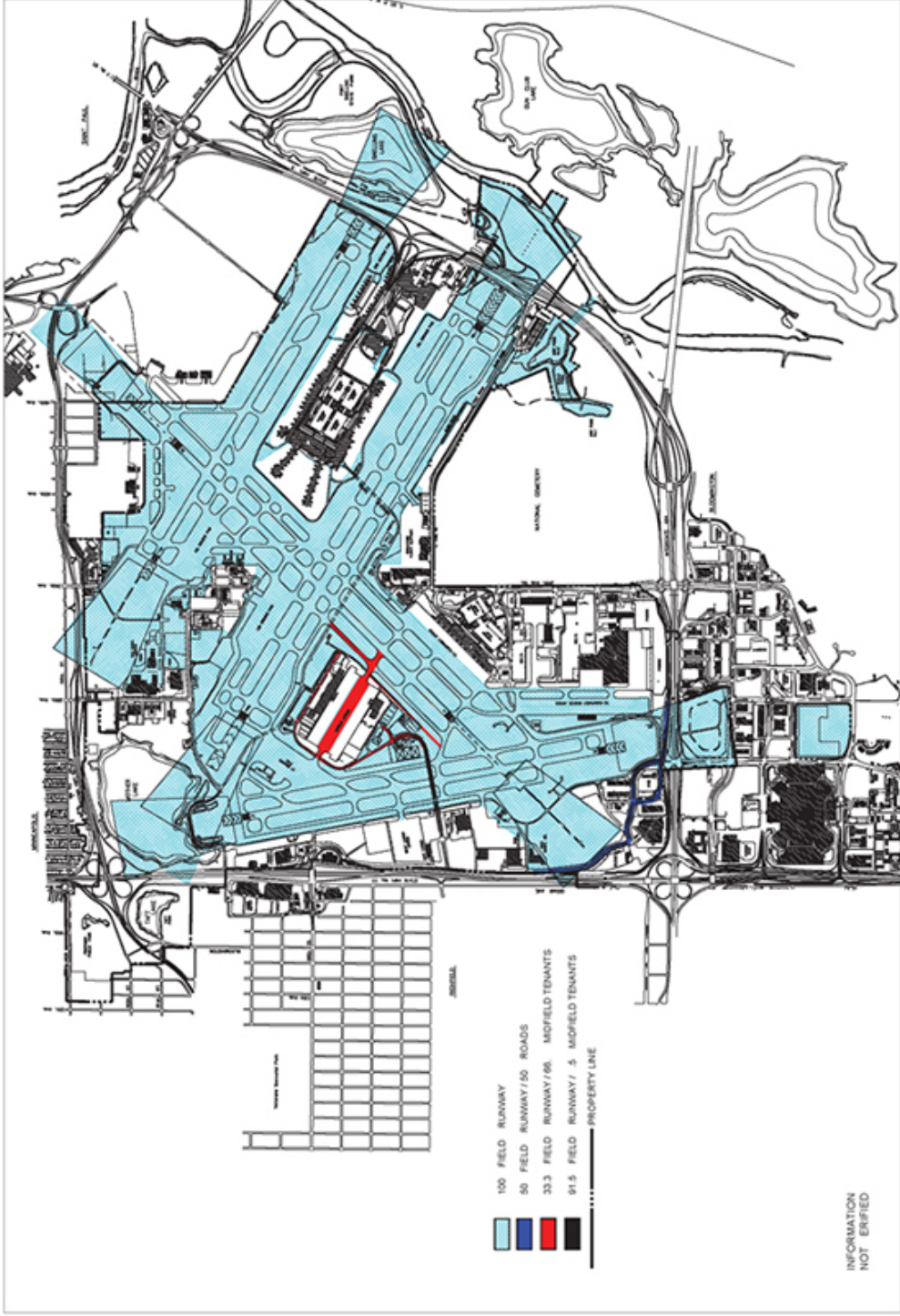

# EXHIBIT C

Date : JANUARY 1, 2019  
 Page 1 of 28

LEGEND  
 TERMINAL BUILDING  
 AREA



Metropolitan Airports Commission  
 6040 29th Avenue So.  
 Minneapolis, MN 55416

Space Category Key

1A	PUBLIC LOBBY
1B	PUBLIC LOBBY
1C	TRAVEL
1D	TRAVEL
1E	TRAVEL
1F	TRAVEL
1G	TRAVEL
1H	TRAVEL
1I	TRAVEL
1J	TRAVEL
1K	TRAVEL
1L	TRAVEL
1M	TRAVEL
1N	TRAVEL
1O	TRAVEL
1P	TRAVEL
1Q	TRAVEL
1R	TRAVEL
1S	TRAVEL
1T	TRAVEL
1U	TRAVEL
1V	TRAVEL
1W	TRAVEL
1X	TRAVEL
1Y	TRAVEL
1Z	TRAVEL
2A	TRAVEL
2B	TRAVEL
2C	TRAVEL
2D	TRAVEL
2E	TRAVEL
2F	TRAVEL
2G	TRAVEL
2H	TRAVEL
2I	TRAVEL
2J	TRAVEL
2K	TRAVEL
2L	TRAVEL
2M	TRAVEL
2N	TRAVEL
2O	TRAVEL
2P	TRAVEL
2Q	TRAVEL
2R	TRAVEL
2S	TRAVEL
2T	TRAVEL
2U	TRAVEL
2V	TRAVEL
2W	TRAVEL
2X	TRAVEL
2Y	TRAVEL
2Z	TRAVEL
3A	TRAVEL
3B	TRAVEL
3C	TRAVEL
3D	TRAVEL
3E	TRAVEL
3F	TRAVEL
3G	TRAVEL
3H	TRAVEL
3I	TRAVEL
3J	TRAVEL
3K	TRAVEL
3L	TRAVEL
3M	TRAVEL
3N	TRAVEL
3O	TRAVEL
3P	TRAVEL
3Q	TRAVEL
3R	TRAVEL
3S	TRAVEL
3T	TRAVEL
3U	TRAVEL
3V	TRAVEL
3W	TRAVEL
3X	TRAVEL
3Y	TRAVEL
3Z	TRAVEL
4A	TRAVEL
4B	TRAVEL
4C	TRAVEL
4D	TRAVEL
4E	TRAVEL
4F	TRAVEL
4G	TRAVEL
4H	TRAVEL
4I	TRAVEL
4J	TRAVEL
4K	TRAVEL
4L	TRAVEL
4M	TRAVEL
4N	TRAVEL
4O	TRAVEL
4P	TRAVEL
4Q	TRAVEL
4R	TRAVEL
4S	TRAVEL
4T	TRAVEL
4U	TRAVEL
4V	TRAVEL
4W	TRAVEL
4X	TRAVEL
4Y	TRAVEL
4Z	TRAVEL
5A	TRAVEL
5B	TRAVEL
5C	TRAVEL
5D	TRAVEL
5E	TRAVEL
5F	TRAVEL
5G	TRAVEL
5H	TRAVEL
5I	TRAVEL
5J	TRAVEL
5K	TRAVEL
5L	TRAVEL
5M	TRAVEL
5N	TRAVEL
5O	TRAVEL
5P	TRAVEL
5Q	TRAVEL
5R	TRAVEL
5S	TRAVEL
5T	TRAVEL
5U	TRAVEL
5V	TRAVEL
5W	TRAVEL
5X	TRAVEL
5Y	TRAVEL
5Z	TRAVEL
6A	TRAVEL
6B	TRAVEL
6C	TRAVEL
6D	TRAVEL
6E	TRAVEL
6F	TRAVEL
6G	TRAVEL
6H	TRAVEL
6I	TRAVEL
6J	TRAVEL
6K	TRAVEL
6L	TRAVEL
6M	TRAVEL
6N	TRAVEL
6O	TRAVEL
6P	TRAVEL
6Q	TRAVEL
6R	TRAVEL
6S	TRAVEL
6T	TRAVEL
6U	TRAVEL
6V	TRAVEL
6W	TRAVEL
6X	TRAVEL
6Y	TRAVEL
6Z	TRAVEL
7A	TRAVEL
7B	TRAVEL
7C	TRAVEL
7D	TRAVEL
7E	TRAVEL
7F	TRAVEL
7G	TRAVEL
7H	TRAVEL
7I	TRAVEL
7J	TRAVEL
7K	TRAVEL
7L	TRAVEL
7M	TRAVEL
7N	TRAVEL
7O	TRAVEL
7P	TRAVEL
7Q	TRAVEL
7R	TRAVEL
7S	TRAVEL
7T	TRAVEL
7U	TRAVEL
7V	TRAVEL
7W	TRAVEL
7X	TRAVEL
7Y	TRAVEL
7Z	TRAVEL
8A	TRAVEL
8B	TRAVEL
8C	TRAVEL
8D	TRAVEL
8E	TRAVEL
8F	TRAVEL
8G	TRAVEL
8H	TRAVEL
8I	TRAVEL
8J	TRAVEL
8K	TRAVEL
8L	TRAVEL
8M	TRAVEL
8N	TRAVEL
8O	TRAVEL
8P	TRAVEL
8Q	TRAVEL
8R	TRAVEL
8S	TRAVEL
8T	TRAVEL
8U	TRAVEL
8V	TRAVEL
8W	TRAVEL
8X	TRAVEL
8Y	TRAVEL
8Z	TRAVEL
9A	TRAVEL
9B	TRAVEL
9C	TRAVEL
9D	TRAVEL
9E	TRAVEL
9F	TRAVEL
9G	TRAVEL
9H	TRAVEL
9I	TRAVEL
9J	TRAVEL
9K	TRAVEL
9L	TRAVEL
9M	TRAVEL
9N	TRAVEL
9O	TRAVEL
9P	TRAVEL
9Q	TRAVEL
9R	TRAVEL
9S	TRAVEL
9T	TRAVEL
9U	TRAVEL
9V	TRAVEL
9W	TRAVEL
9X	TRAVEL
9Y	TRAVEL
9Z	TRAVEL

MINNEAPOLIS / ST. PAUL  
 INTERNATIONAL AIRPORT  
 TERMINAL BUILDING

Area  
 FM002

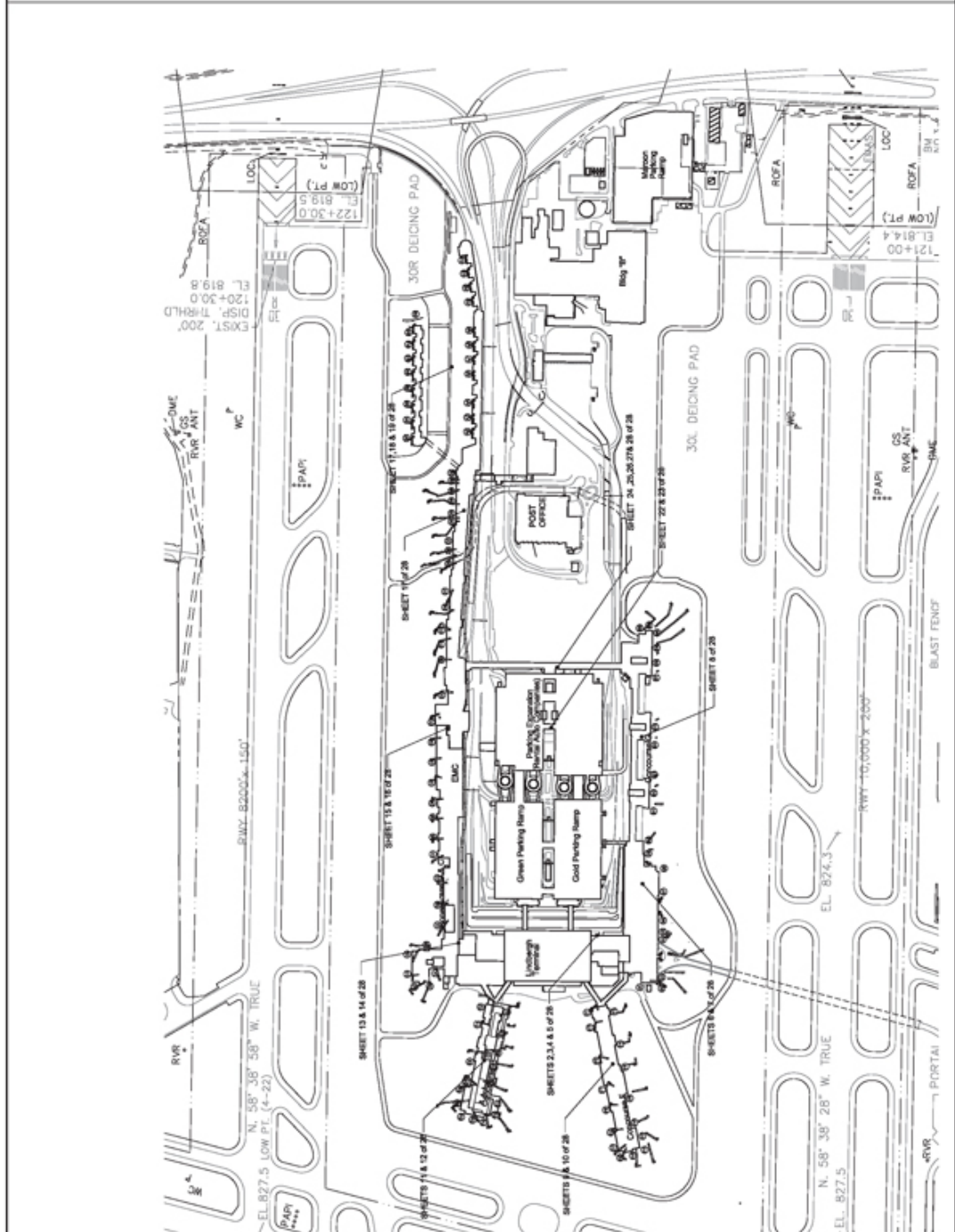

# EXHIBIT C

Date : JANUARY 1, 2019  
 Page 2 of 28

LEGEND  
 TERMINAL BUILDING AREA



Metropolitan Airports Commission  
 6040 29th Avenue So.  
 Minneapolis, MN 55416



**Space Category Key**

1A	PUBLIC CONCOURSE
1B	PUBLIC CONCOURSE
1C	PUBLIC CONCOURSE
1D	PUBLIC CONCOURSE
1E	PUBLIC CONCOURSE
1F	PUBLIC CONCOURSE
1G	PUBLIC CONCOURSE
1H	PUBLIC CONCOURSE
1I	PUBLIC CONCOURSE
1J	PUBLIC CONCOURSE
1K	PUBLIC CONCOURSE
1L	PUBLIC CONCOURSE
1M	PUBLIC CONCOURSE
1N	PUBLIC CONCOURSE
1O	PUBLIC CONCOURSE
1P	PUBLIC CONCOURSE
1Q	PUBLIC CONCOURSE
1R	PUBLIC CONCOURSE
1S	PUBLIC CONCOURSE
1T	PUBLIC CONCOURSE
1U	PUBLIC CONCOURSE
1V	PUBLIC CONCOURSE
1W	PUBLIC CONCOURSE
1X	PUBLIC CONCOURSE
1Y	PUBLIC CONCOURSE
1Z	PUBLIC CONCOURSE
2A	NON-ADJACENT FOOD & BEVERAGE
2B	NON-ADJACENT FOOD & BEVERAGE
2C	NON-ADJACENT FOOD & BEVERAGE
2D	NON-ADJACENT FOOD & BEVERAGE
2E	NON-ADJACENT FOOD & BEVERAGE
2F	NON-ADJACENT FOOD & BEVERAGE
2G	NON-ADJACENT FOOD & BEVERAGE
2H	NON-ADJACENT FOOD & BEVERAGE
2I	NON-ADJACENT FOOD & BEVERAGE
2J	NON-ADJACENT FOOD & BEVERAGE
2K	NON-ADJACENT FOOD & BEVERAGE
2L	NON-ADJACENT FOOD & BEVERAGE
2M	NON-ADJACENT FOOD & BEVERAGE
2N	NON-ADJACENT FOOD & BEVERAGE
2O	NON-ADJACENT FOOD & BEVERAGE
2P	NON-ADJACENT FOOD & BEVERAGE
2Q	NON-ADJACENT FOOD & BEVERAGE
2R	NON-ADJACENT FOOD & BEVERAGE
2S	NON-ADJACENT FOOD & BEVERAGE
2T	NON-ADJACENT FOOD & BEVERAGE
2U	NON-ADJACENT FOOD & BEVERAGE
2V	NON-ADJACENT FOOD & BEVERAGE
2W	NON-ADJACENT FOOD & BEVERAGE
2X	NON-ADJACENT FOOD & BEVERAGE
2Y	NON-ADJACENT FOOD & BEVERAGE
2Z	NON-ADJACENT FOOD & BEVERAGE
3A	ARRIVAL CONCOURSE
3B	ARRIVAL CONCOURSE
3C	ARRIVAL CONCOURSE
3D	ARRIVAL CONCOURSE
3E	ARRIVAL CONCOURSE
3F	ARRIVAL CONCOURSE
3G	ARRIVAL CONCOURSE
3H	ARRIVAL CONCOURSE
3I	ARRIVAL CONCOURSE
3J	ARRIVAL CONCOURSE
3K	ARRIVAL CONCOURSE
3L	ARRIVAL CONCOURSE
3M	ARRIVAL CONCOURSE
3N	ARRIVAL CONCOURSE
3O	ARRIVAL CONCOURSE
3P	ARRIVAL CONCOURSE
3Q	ARRIVAL CONCOURSE
3R	ARRIVAL CONCOURSE
3S	ARRIVAL CONCOURSE
3T	ARRIVAL CONCOURSE
3U	ARRIVAL CONCOURSE
3V	ARRIVAL CONCOURSE
3W	ARRIVAL CONCOURSE
3X	ARRIVAL CONCOURSE
3Y	ARRIVAL CONCOURSE
3Z	ARRIVAL CONCOURSE
4A	ARRIVAL CONCOURSE
4B	ARRIVAL CONCOURSE
4C	ARRIVAL CONCOURSE
4D	ARRIVAL CONCOURSE
4E	ARRIVAL CONCOURSE
4F	ARRIVAL CONCOURSE
4G	ARRIVAL CONCOURSE
4H	ARRIVAL CONCOURSE
4I	ARRIVAL CONCOURSE
4J	ARRIVAL CONCOURSE
4K	ARRIVAL CONCOURSE
4L	ARRIVAL CONCOURSE
4M	ARRIVAL CONCOURSE
4N	ARRIVAL CONCOURSE
4O	ARRIVAL CONCOURSE
4P	ARRIVAL CONCOURSE
4Q	ARRIVAL CONCOURSE
4R	ARRIVAL CONCOURSE
4S	ARRIVAL CONCOURSE
4T	ARRIVAL CONCOURSE
4U	ARRIVAL CONCOURSE
4V	ARRIVAL CONCOURSE
4W	ARRIVAL CONCOURSE
4X	ARRIVAL CONCOURSE
4Y	ARRIVAL CONCOURSE
4Z	ARRIVAL CONCOURSE
5A	ARRIVAL CONCOURSE
5B	ARRIVAL CONCOURSE
5C	ARRIVAL CONCOURSE
5D	ARRIVAL CONCOURSE
5E	ARRIVAL CONCOURSE
5F	ARRIVAL CONCOURSE
5G	ARRIVAL CONCOURSE
5H	ARRIVAL CONCOURSE
5I	ARRIVAL CONCOURSE
5J	ARRIVAL CONCOURSE
5K	ARRIVAL CONCOURSE
5L	ARRIVAL CONCOURSE
5M	ARRIVAL CONCOURSE
5N	ARRIVAL CONCOURSE
5O	ARRIVAL CONCOURSE
5P	ARRIVAL CONCOURSE
5Q	ARRIVAL CONCOURSE
5R	ARRIVAL CONCOURSE
5S	ARRIVAL CONCOURSE
5T	ARRIVAL CONCOURSE
5U	ARRIVAL CONCOURSE
5V	ARRIVAL CONCOURSE
5W	ARRIVAL CONCOURSE
5X	ARRIVAL CONCOURSE
5Y	ARRIVAL CONCOURSE
5Z	ARRIVAL CONCOURSE

MINNEAPOLIS / ST. PAUL INTERNATIONAL AIRPORT  
 TERMINAL BUILDING

MAIN TERMINAL  
 BASEMENT PLAN

FM100

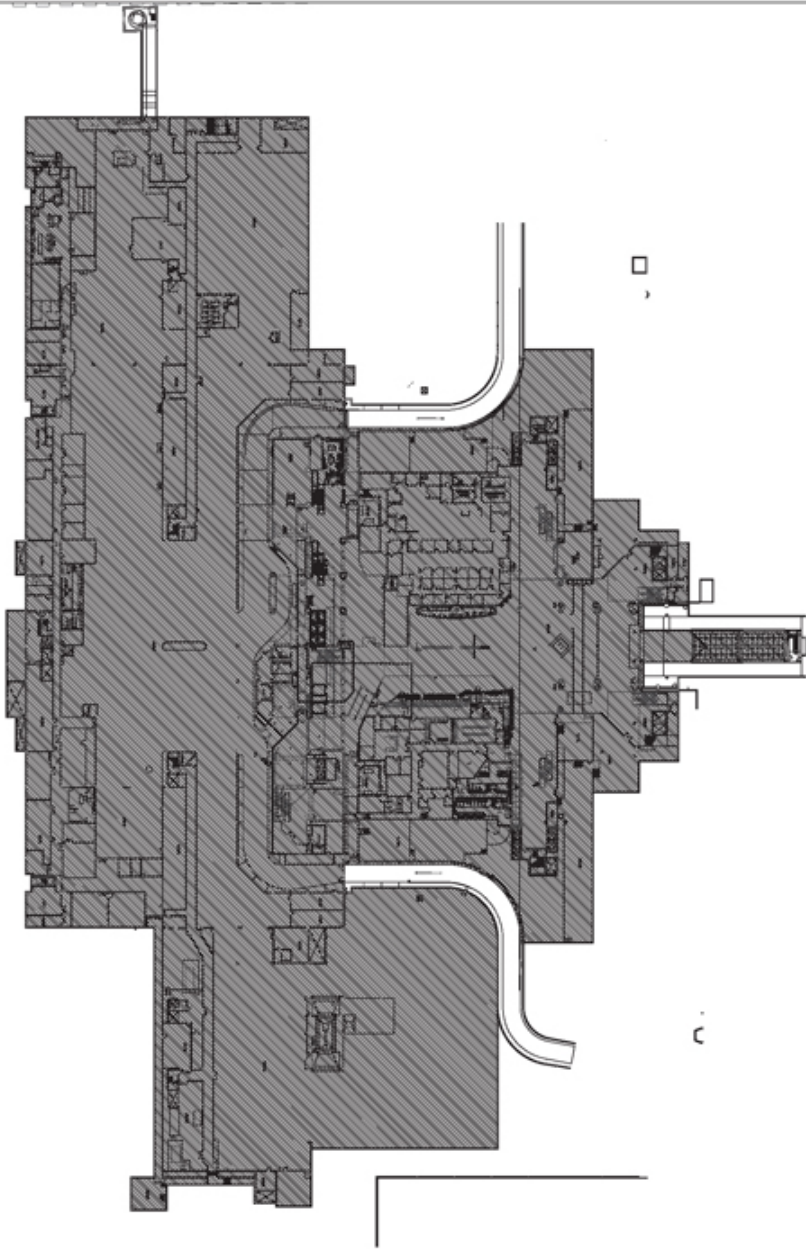



# EXHIBIT C

Date : JANUARY 1, 2019  
 Page 3 of 28

LEGEND  
 TERMINAL BUILDING AREA



Metropolitan Airports Commission  
 6040 29th Avenue So.  
 Minneapolis, MN 55416



**Space Category Key**

1A	PUBLIC CONCOURSE
1B	TRAVEL
1C	TRAVEL
1D	TRAVEL
1E	TRAVEL
1F	TRAVEL
1G	TRAVEL
1H	TRAVEL
1I	TRAVEL
1J	TRAVEL
1K	TRAVEL
1L	TRAVEL
1M	TRAVEL
1N	TRAVEL
1O	TRAVEL
1P	TRAVEL
1Q	TRAVEL
1R	TRAVEL
1S	TRAVEL
1T	TRAVEL
1U	TRAVEL
1V	TRAVEL
1W	TRAVEL
1X	TRAVEL
1Y	TRAVEL
1Z	TRAVEL
2A	TRAVEL
2B	TRAVEL
2C	TRAVEL
2D	TRAVEL
2E	TRAVEL
2F	TRAVEL
2G	TRAVEL
2H	TRAVEL
2I	TRAVEL
2J	TRAVEL
2K	TRAVEL
2L	TRAVEL
2M	TRAVEL
2N	TRAVEL
2O	TRAVEL
2P	TRAVEL
2Q	TRAVEL
2R	TRAVEL
2S	TRAVEL
2T	TRAVEL
2U	TRAVEL
2V	TRAVEL
2W	TRAVEL
2X	TRAVEL
2Y	TRAVEL
2Z	TRAVEL
3A	TRAVEL
3B	TRAVEL
3C	TRAVEL
3D	TRAVEL
3E	TRAVEL
3F	TRAVEL
3G	TRAVEL
3H	TRAVEL
3I	TRAVEL
3J	TRAVEL
3K	TRAVEL
3L	TRAVEL
3M	TRAVEL
3N	TRAVEL
3O	TRAVEL
3P	TRAVEL
3Q	TRAVEL
3R	TRAVEL
3S	TRAVEL
3T	TRAVEL
3U	TRAVEL
3V	TRAVEL
3W	TRAVEL
3X	TRAVEL
3Y	TRAVEL
3Z	TRAVEL
4A	TRAVEL
4B	TRAVEL
4C	TRAVEL
4D	TRAVEL
4E	TRAVEL
4F	TRAVEL
4G	TRAVEL
4H	TRAVEL
4I	TRAVEL
4J	TRAVEL
4K	TRAVEL
4L	TRAVEL
4M	TRAVEL
4N	TRAVEL
4O	TRAVEL
4P	TRAVEL
4Q	TRAVEL
4R	TRAVEL
4S	TRAVEL
4T	TRAVEL
4U	TRAVEL
4V	TRAVEL
4W	TRAVEL
4X	TRAVEL
4Y	TRAVEL
4Z	TRAVEL
5A	TRAVEL
5B	TRAVEL
5C	TRAVEL
5D	TRAVEL
5E	TRAVEL
5F	TRAVEL
5G	TRAVEL
5H	TRAVEL
5I	TRAVEL
5J	TRAVEL
5K	TRAVEL
5L	TRAVEL
5M	TRAVEL
5N	TRAVEL
5O	TRAVEL
5P	TRAVEL
5Q	TRAVEL
5R	TRAVEL
5S	TRAVEL
5T	TRAVEL
5U	TRAVEL
5V	TRAVEL
5W	TRAVEL
5X	TRAVEL
5Y	TRAVEL
5Z	TRAVEL
6A	TRAVEL
6B	TRAVEL
6C	TRAVEL
6D	TRAVEL
6E	TRAVEL
6F	TRAVEL
6G	TRAVEL
6H	TRAVEL
6I	TRAVEL
6J	TRAVEL
6K	TRAVEL
6L	TRAVEL
6M	TRAVEL
6N	TRAVEL
6O	TRAVEL
6P	TRAVEL
6Q	TRAVEL
6R	TRAVEL
6S	TRAVEL
6T	TRAVEL
6U	TRAVEL
6V	TRAVEL
6W	TRAVEL
6X	TRAVEL
6Y	TRAVEL
6Z	TRAVEL
7A	TRAVEL
7B	TRAVEL
7C	TRAVEL
7D	TRAVEL
7E	TRAVEL
7F	TRAVEL
7G	TRAVEL
7H	TRAVEL
7I	TRAVEL
7J	TRAVEL
7K	TRAVEL
7L	TRAVEL
7M	TRAVEL
7N	TRAVEL
7O	TRAVEL
7P	TRAVEL
7Q	TRAVEL
7R	TRAVEL
7S	TRAVEL
7T	TRAVEL
7U	TRAVEL
7V	TRAVEL
7W	TRAVEL
7X	TRAVEL
7Y	TRAVEL
7Z	TRAVEL
8A	TRAVEL
8B	TRAVEL
8C	TRAVEL
8D	TRAVEL
8E	TRAVEL
8F	TRAVEL
8G	TRAVEL
8H	TRAVEL
8I	TRAVEL
8J	TRAVEL
8K	TRAVEL
8L	TRAVEL
8M	TRAVEL
8N	TRAVEL
8O	TRAVEL
8P	TRAVEL
8Q	TRAVEL
8R	TRAVEL
8S	TRAVEL
8T	TRAVEL
8U	TRAVEL
8V	TRAVEL
8W	TRAVEL
8X	TRAVEL
8Y	TRAVEL
8Z	TRAVEL
9A	TRAVEL
9B	TRAVEL
9C	TRAVEL
9D	TRAVEL
9E	TRAVEL
9F	TRAVEL
9G	TRAVEL
9H	TRAVEL
9I	TRAVEL
9J	TRAVEL
9K	TRAVEL
9L	TRAVEL
9M	TRAVEL
9N	TRAVEL
9O	TRAVEL
9P	TRAVEL
9Q	TRAVEL
9R	TRAVEL
9S	TRAVEL
9T	TRAVEL
9U	TRAVEL
9V	TRAVEL
9W	TRAVEL
9X	TRAVEL
9Y	TRAVEL
9Z	TRAVEL

MINNEAPOLIS / ST. PAUL INTERNATIONAL AIRPORT  
 TERMINAL BUILDING

MAIN TERMINAL BAGGAGE CLAIM

FM101

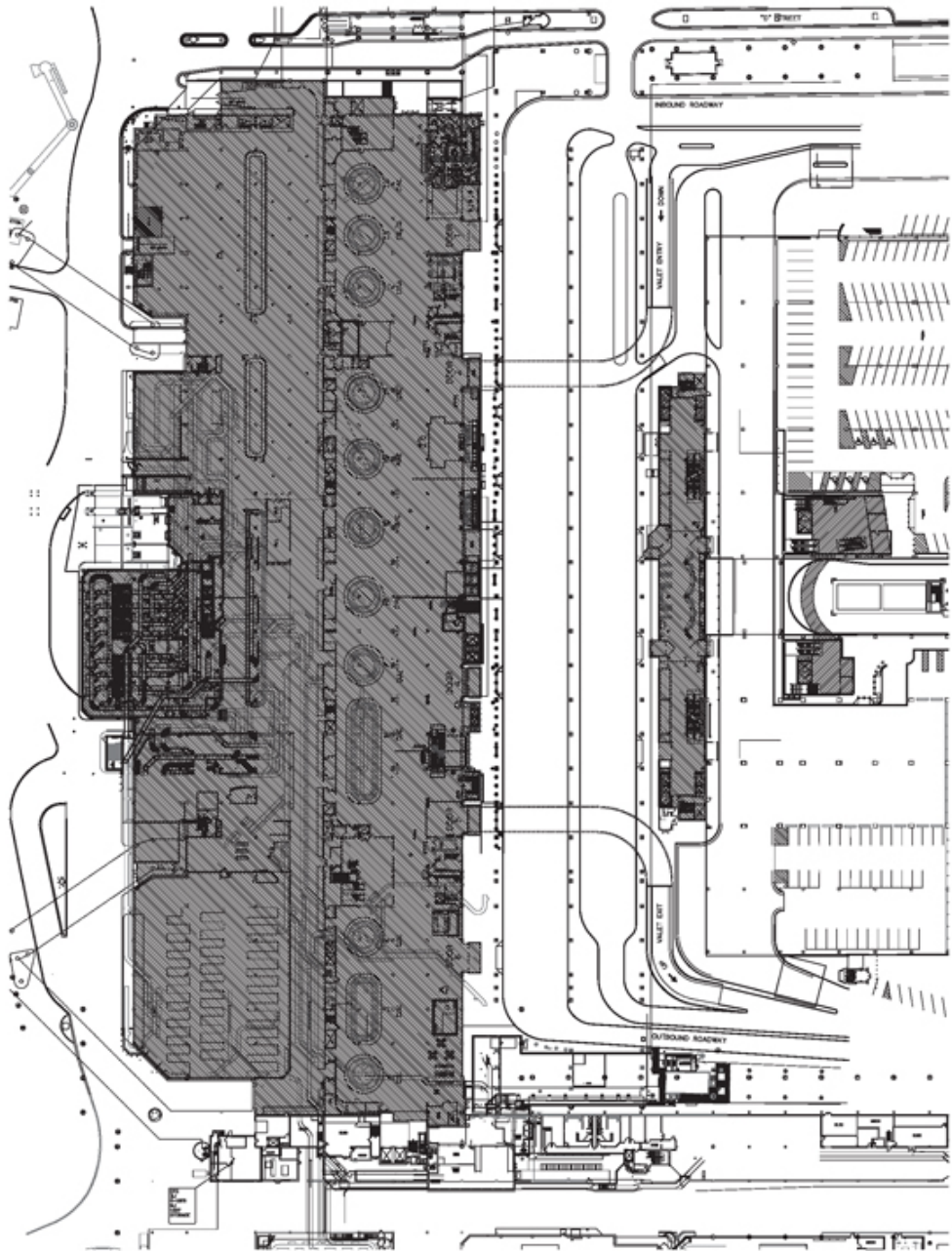

# EXHIBIT C

Date : JANUARY 1, 2019  
 Page 4 of 28

LEGEND  
 TERMINAL BUILDING  
 ASIA



Metropolitan Airports Commission  
 6040 29th Avenue So.  
 Minneapolis, MN 55410

Space Category Key

1	SPOT
2	SHIRT
3	SHIRT
4	SHIRT
5	SHIRT
6	SHIRT
7	SHIRT
8	SHIRT
9	SHIRT
10	SHIRT
11	SHIRT
12	SHIRT
13	SHIRT
14	SHIRT
15	SHIRT
16	SHIRT
17	SHIRT
18	SHIRT
19	SHIRT
20	SHIRT
21	SHIRT
22	SHIRT
23	SHIRT
24	SHIRT
25	SHIRT
26	SHIRT
27	SHIRT
28	SHIRT
29	SHIRT
30	SHIRT
31	SHIRT
32	SHIRT
33	SHIRT
34	SHIRT
35	SHIRT
36	SHIRT
37	SHIRT
38	SHIRT
39	SHIRT
40	SHIRT
41	SHIRT
42	SHIRT
43	SHIRT
44	SHIRT
45	SHIRT
46	SHIRT
47	SHIRT
48	SHIRT
49	SHIRT
50	SHIRT
51	SHIRT
52	SHIRT
53	SHIRT
54	SHIRT
55	SHIRT
56	SHIRT
57	SHIRT
58	SHIRT
59	SHIRT
60	SHIRT
61	SHIRT
62	SHIRT
63	SHIRT
64	SHIRT
65	SHIRT
66	SHIRT
67	SHIRT
68	SHIRT
69	SHIRT
70	SHIRT
71	SHIRT
72	SHIRT
73	SHIRT
74	SHIRT
75	SHIRT
76	SHIRT
77	SHIRT
78	SHIRT
79	SHIRT
80	SHIRT
81	SHIRT
82	SHIRT
83	SHIRT
84	SHIRT
85	SHIRT
86	SHIRT
87	SHIRT
88	SHIRT
89	SHIRT
90	SHIRT
91	SHIRT
92	SHIRT
93	SHIRT
94	SHIRT
95	SHIRT
96	SHIRT
97	SHIRT
98	SHIRT
99	SHIRT
100	SHIRT

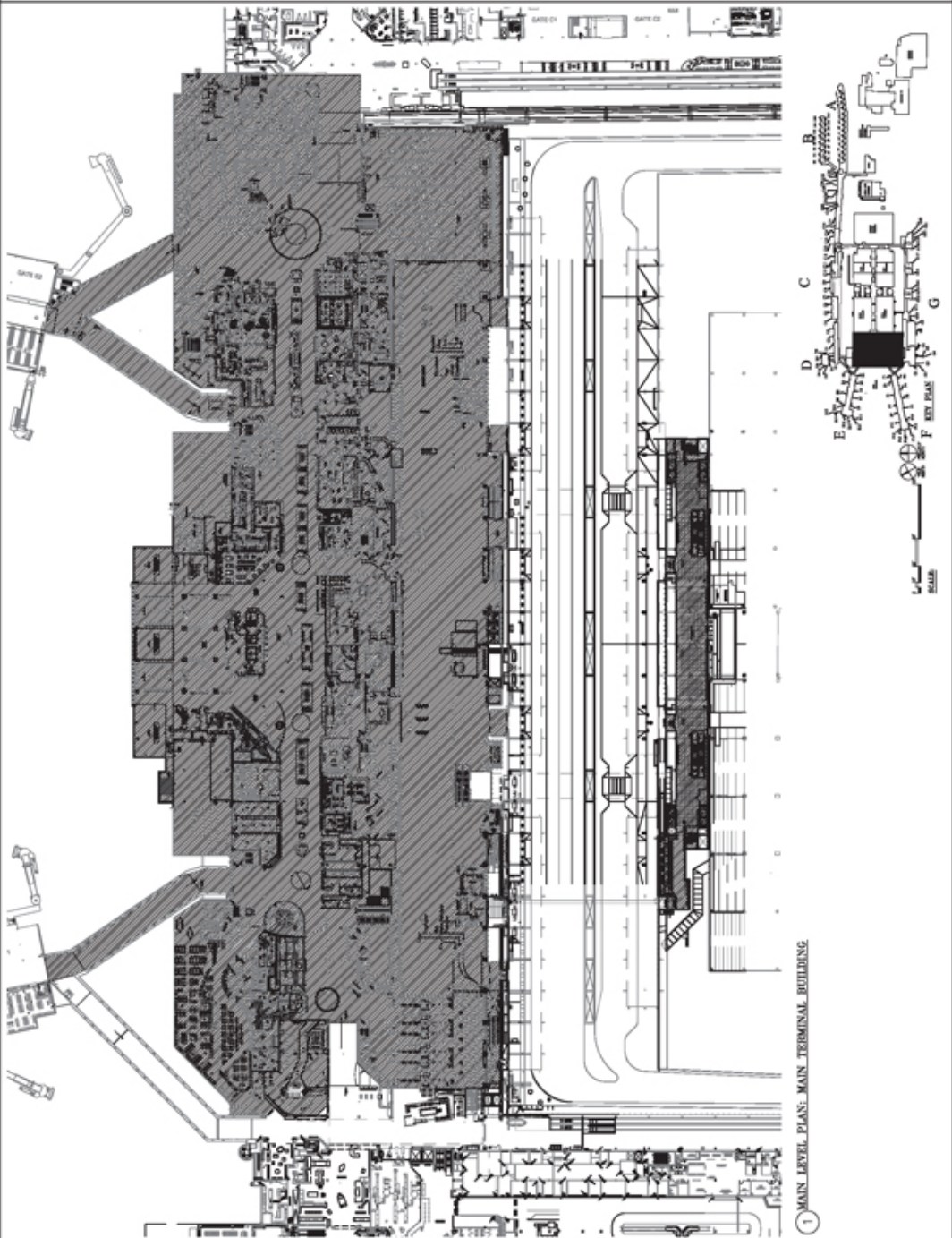

1 MAIN LEVEL PLAN: MAIN TERMINAL BUILDING

MINNEAPOLIS/ST PAUL  
 INTERNATIONAL AIRPORT  
 TERMINAL BUILDING  
 MAIN TERMINAL  
 TICKETING LEVEL  
 FM102





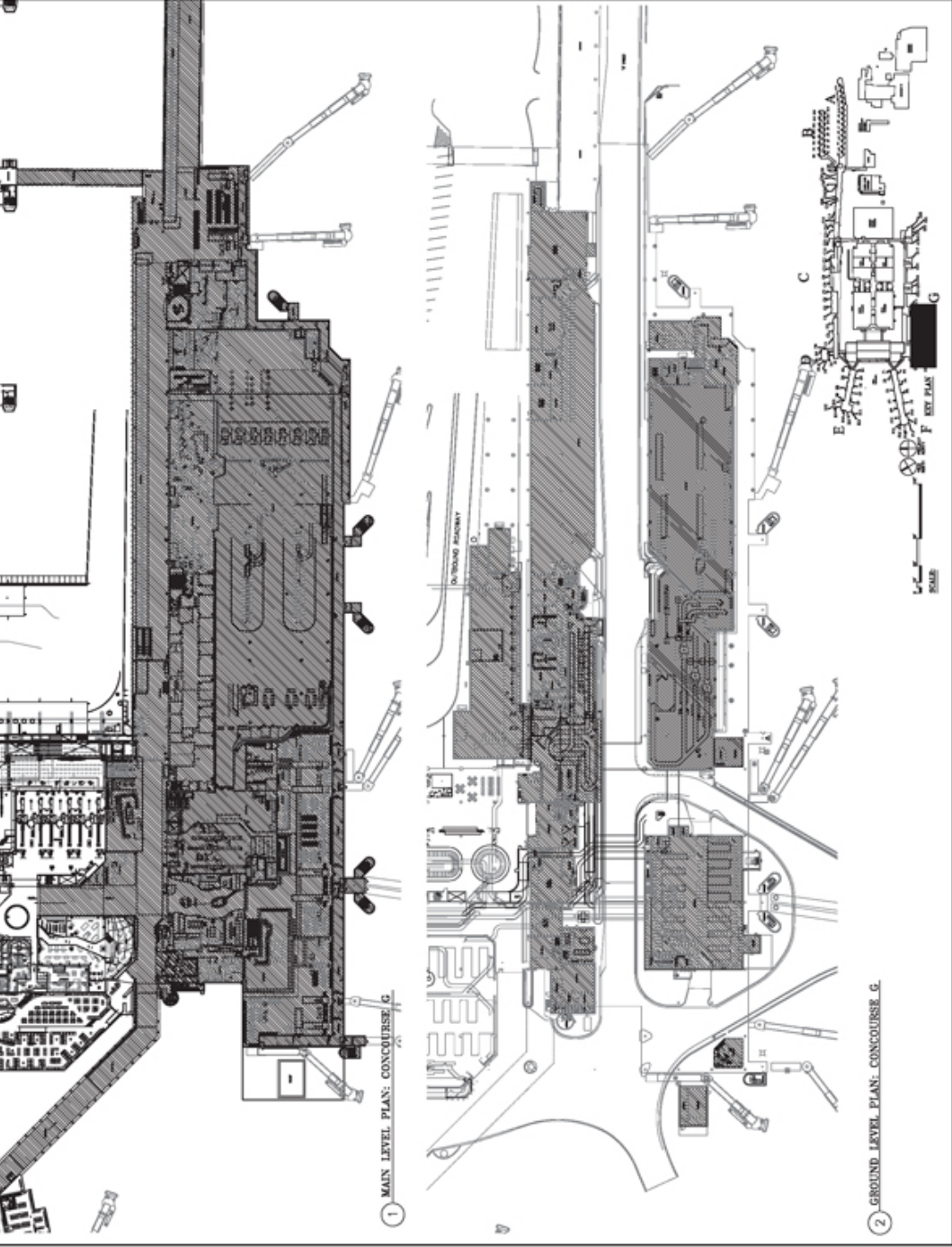

**Space Category Key**

1	TRAVEL
2	SPACE OUTDOOR
3	NON-ADJACENT
4	NON-ADJACENT
5	NON-ADJACENT
6	NON-ADJACENT
7	NON-ADJACENT
8	NON-ADJACENT
9	NON-ADJACENT
10	NON-ADJACENT
11	NON-ADJACENT
12	NON-ADJACENT
13	NON-ADJACENT
14	NON-ADJACENT
15	NON-ADJACENT
16	NON-ADJACENT
17	NON-ADJACENT
18	NON-ADJACENT
19	NON-ADJACENT
20	NON-ADJACENT
21	NON-ADJACENT
22	NON-ADJACENT
23	NON-ADJACENT
24	NON-ADJACENT
25	NON-ADJACENT
26	NON-ADJACENT
27	NON-ADJACENT
28	NON-ADJACENT
29	NON-ADJACENT
30	NON-ADJACENT
31	NON-ADJACENT
32	NON-ADJACENT
33	NON-ADJACENT
34	NON-ADJACENT
35	NON-ADJACENT
36	NON-ADJACENT
37	NON-ADJACENT
38	NON-ADJACENT
39	NON-ADJACENT
40	NON-ADJACENT
41	NON-ADJACENT
42	NON-ADJACENT
43	NON-ADJACENT
44	NON-ADJACENT
45	NON-ADJACENT
46	NON-ADJACENT
47	NON-ADJACENT
48	NON-ADJACENT
49	NON-ADJACENT
50	NON-ADJACENT
51	NON-ADJACENT
52	NON-ADJACENT
53	NON-ADJACENT
54	NON-ADJACENT
55	NON-ADJACENT
56	NON-ADJACENT
57	NON-ADJACENT
58	NON-ADJACENT
59	NON-ADJACENT
60	NON-ADJACENT
61	NON-ADJACENT
62	NON-ADJACENT
63	NON-ADJACENT
64	NON-ADJACENT
65	NON-ADJACENT
66	NON-ADJACENT
67	NON-ADJACENT
68	NON-ADJACENT
69	NON-ADJACENT
70	NON-ADJACENT
71	NON-ADJACENT
72	NON-ADJACENT
73	NON-ADJACENT
74	NON-ADJACENT
75	NON-ADJACENT
76	NON-ADJACENT
77	NON-ADJACENT
78	NON-ADJACENT
79	NON-ADJACENT
80	NON-ADJACENT
81	NON-ADJACENT
82	NON-ADJACENT
83	NON-ADJACENT
84	NON-ADJACENT
85	NON-ADJACENT
86	NON-ADJACENT
87	NON-ADJACENT
88	NON-ADJACENT
89	NON-ADJACENT
90	NON-ADJACENT
91	NON-ADJACENT
92	NON-ADJACENT
93	NON-ADJACENT
94	NON-ADJACENT
95	NON-ADJACENT
96	NON-ADJACENT
97	NON-ADJACENT
98	NON-ADJACENT
99	NON-ADJACENT
100	NON-ADJACENT

# EXHIBIT C

Date : JANUARY 1, 2019  
 Page 7 of 28

LEGEND  
 TERMINAL BUILDING AREA



Metropolitan Airports Commission  
 6040 29th Avenue So.  
 Minneapolis, MN 55416

Space Category Key

1	TRAVEL
2	TRAVEL
3	TRAVEL
4	TRAVEL
5	TRAVEL
6	TRAVEL
7	TRAVEL
8	TRAVEL
9	TRAVEL
10	TRAVEL
11	TRAVEL
12	TRAVEL
13	TRAVEL
14	TRAVEL
15	TRAVEL
16	TRAVEL
17	TRAVEL
18	TRAVEL
19	TRAVEL
20	TRAVEL
21	TRAVEL
22	TRAVEL
23	TRAVEL
24	TRAVEL
25	TRAVEL
26	TRAVEL
27	TRAVEL
28	TRAVEL
29	TRAVEL
30	TRAVEL
31	TRAVEL
32	TRAVEL
33	TRAVEL
34	TRAVEL
35	TRAVEL
36	TRAVEL
37	TRAVEL
38	TRAVEL
39	TRAVEL
40	TRAVEL
41	TRAVEL
42	TRAVEL
43	TRAVEL
44	TRAVEL
45	TRAVEL
46	TRAVEL
47	TRAVEL
48	TRAVEL
49	TRAVEL
50	TRAVEL
51	TRAVEL
52	TRAVEL
53	TRAVEL
54	TRAVEL
55	TRAVEL
56	TRAVEL
57	TRAVEL
58	TRAVEL
59	TRAVEL
60	TRAVEL
61	TRAVEL
62	TRAVEL
63	TRAVEL
64	TRAVEL
65	TRAVEL
66	TRAVEL
67	TRAVEL
68	TRAVEL
69	TRAVEL
70	TRAVEL
71	TRAVEL
72	TRAVEL
73	TRAVEL
74	TRAVEL
75	TRAVEL
76	TRAVEL
77	TRAVEL
78	TRAVEL
79	TRAVEL
80	TRAVEL
81	TRAVEL
82	TRAVEL
83	TRAVEL
84	TRAVEL
85	TRAVEL
86	TRAVEL
87	TRAVEL
88	TRAVEL
89	TRAVEL
90	TRAVEL
91	TRAVEL
92	TRAVEL
93	TRAVEL
94	TRAVEL
95	TRAVEL
96	TRAVEL
97	TRAVEL
98	TRAVEL
99	TRAVEL
100	TRAVEL

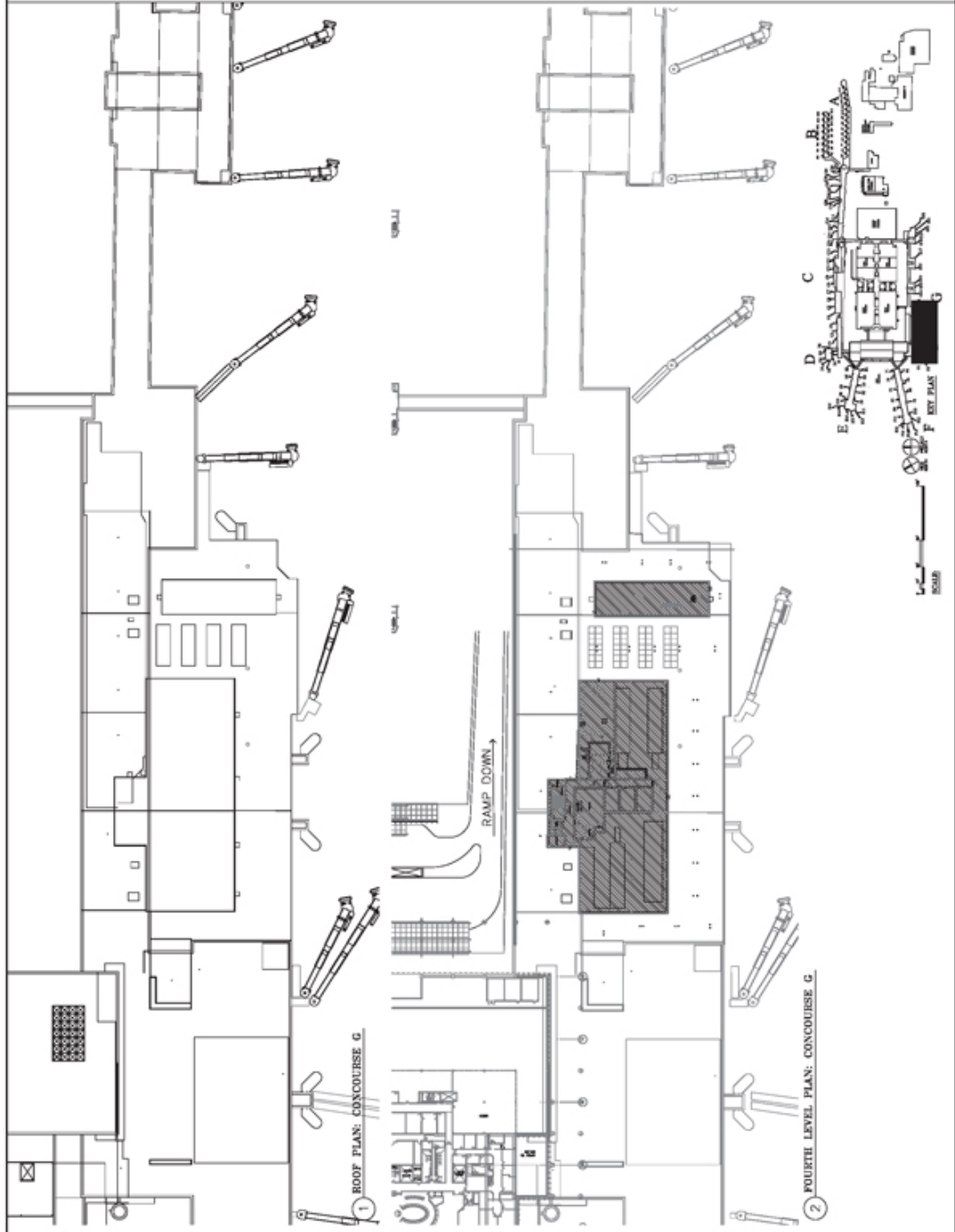



# EXHIBIT C

Date : JANUARY 1, 2019  
 Page 8 of 28

LEGEND  
 TERMINAL BUILDING  
 AREA



Metropolitan  
 Airports  
 Commission  
 6040 29th Avenue So.  
 Minneapolis, MN 55416

Space Category Key

1	TRAVEL VESTIBULE
2	TRAVEL VESTIBULE
3	TRAVEL VESTIBULE
4	TRAVEL VESTIBULE
5	TRAVEL VESTIBULE
6	TRAVEL VESTIBULE
7	TRAVEL VESTIBULE
8	TRAVEL VESTIBULE
9	TRAVEL VESTIBULE
10	TRAVEL VESTIBULE
11	TRAVEL VESTIBULE
12	TRAVEL VESTIBULE
13	TRAVEL VESTIBULE
14	TRAVEL VESTIBULE
15	TRAVEL VESTIBULE
16	TRAVEL VESTIBULE
17	TRAVEL VESTIBULE
18	TRAVEL VESTIBULE
19	TRAVEL VESTIBULE
20	TRAVEL VESTIBULE
21	TRAVEL VESTIBULE
22	TRAVEL VESTIBULE
23	TRAVEL VESTIBULE
24	TRAVEL VESTIBULE
25	TRAVEL VESTIBULE
26	TRAVEL VESTIBULE
27	TRAVEL VESTIBULE
28	TRAVEL VESTIBULE
29	TRAVEL VESTIBULE
30	TRAVEL VESTIBULE
31	TRAVEL VESTIBULE
32	TRAVEL VESTIBULE
33	TRAVEL VESTIBULE
34	TRAVEL VESTIBULE
35	TRAVEL VESTIBULE
36	TRAVEL VESTIBULE
37	TRAVEL VESTIBULE
38	TRAVEL VESTIBULE
39	TRAVEL VESTIBULE
40	TRAVEL VESTIBULE
41	TRAVEL VESTIBULE
42	TRAVEL VESTIBULE
43	TRAVEL VESTIBULE
44	TRAVEL VESTIBULE
45	TRAVEL VESTIBULE
46	TRAVEL VESTIBULE
47	TRAVEL VESTIBULE
48	TRAVEL VESTIBULE
49	TRAVEL VESTIBULE
50	TRAVEL VESTIBULE
51	TRAVEL VESTIBULE
52	TRAVEL VESTIBULE
53	TRAVEL VESTIBULE
54	TRAVEL VESTIBULE
55	TRAVEL VESTIBULE
56	TRAVEL VESTIBULE
57	TRAVEL VESTIBULE
58	TRAVEL VESTIBULE
59	TRAVEL VESTIBULE
60	TRAVEL VESTIBULE
61	TRAVEL VESTIBULE
62	TRAVEL VESTIBULE
63	TRAVEL VESTIBULE
64	TRAVEL VESTIBULE
65	TRAVEL VESTIBULE
66	TRAVEL VESTIBULE
67	TRAVEL VESTIBULE
68	TRAVEL VESTIBULE
69	TRAVEL VESTIBULE
70	TRAVEL VESTIBULE
71	TRAVEL VESTIBULE
72	TRAVEL VESTIBULE
73	TRAVEL VESTIBULE
74	TRAVEL VESTIBULE
75	TRAVEL VESTIBULE
76	TRAVEL VESTIBULE
77	TRAVEL VESTIBULE
78	TRAVEL VESTIBULE
79	TRAVEL VESTIBULE
80	TRAVEL VESTIBULE
81	TRAVEL VESTIBULE
82	TRAVEL VESTIBULE
83	TRAVEL VESTIBULE
84	TRAVEL VESTIBULE
85	TRAVEL VESTIBULE
86	TRAVEL VESTIBULE
87	TRAVEL VESTIBULE
88	TRAVEL VESTIBULE
89	TRAVEL VESTIBULE
90	TRAVEL VESTIBULE
91	TRAVEL VESTIBULE
92	TRAVEL VESTIBULE
93	TRAVEL VESTIBULE
94	TRAVEL VESTIBULE
95	TRAVEL VESTIBULE
96	TRAVEL VESTIBULE
97	TRAVEL VESTIBULE
98	TRAVEL VESTIBULE
99	TRAVEL VESTIBULE
100	TRAVEL VESTIBULE

MINNEAPOLIS / ST PAUL  
 INTERNATIONAL AIRPORT  
 TERMINAL BUILDING  
 CONCOURSE G

FM108

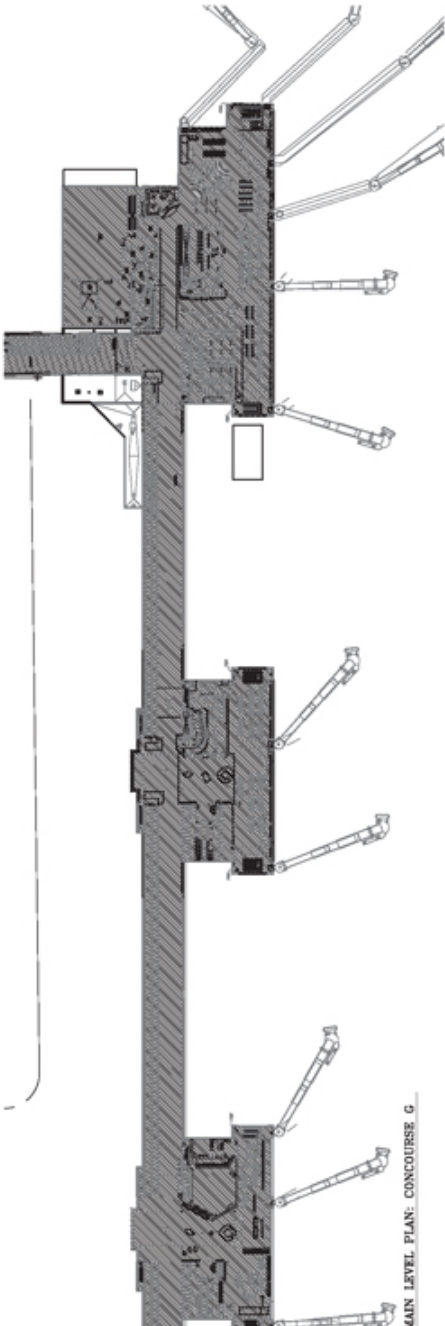

1 MAIN LEVEL PLAN: CONCOURSE G

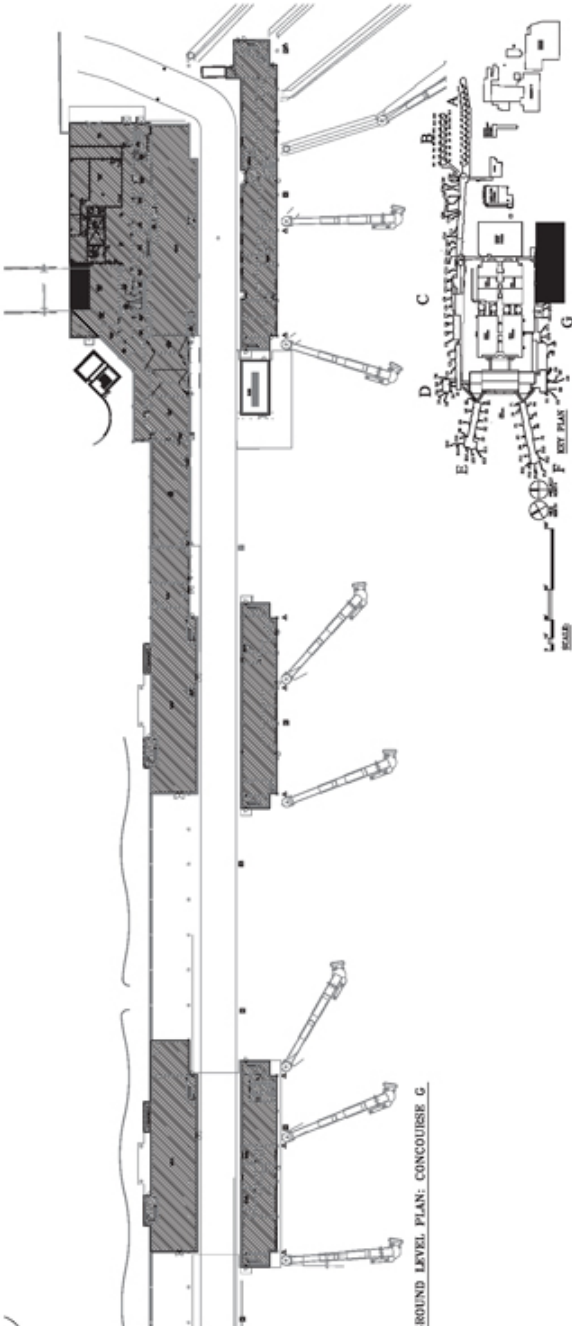

2 GROUND LEVEL PLAN: CONCOURSE G

**EXHIBIT C**

Date : JANUARY 1, 2019  
 Page 9 of 28

TERMINAL BUILDING  
 ASGA



Metropolitan  
 Airports  
 Commission  
 Minneapolis, MN 55401

**Space Category Key**

1	TRAVEL CONCOURSE
2	TRAVEL CONCOURSE
3	TRAVEL CONCOURSE
4	TRAVEL CONCOURSE
5	TRAVEL CONCOURSE
6	TRAVEL CONCOURSE
7	TRAVEL CONCOURSE
8	TRAVEL CONCOURSE
9	TRAVEL CONCOURSE
10	TRAVEL CONCOURSE
11	TRAVEL CONCOURSE
12	TRAVEL CONCOURSE
13	TRAVEL CONCOURSE
14	TRAVEL CONCOURSE
15	TRAVEL CONCOURSE
16	TRAVEL CONCOURSE
17	TRAVEL CONCOURSE
18	TRAVEL CONCOURSE
19	TRAVEL CONCOURSE
20	TRAVEL CONCOURSE
21	TRAVEL CONCOURSE
22	TRAVEL CONCOURSE
23	TRAVEL CONCOURSE
24	TRAVEL CONCOURSE
25	TRAVEL CONCOURSE
26	TRAVEL CONCOURSE
27	TRAVEL CONCOURSE
28	TRAVEL CONCOURSE
29	TRAVEL CONCOURSE
30	TRAVEL CONCOURSE
31	TRAVEL CONCOURSE
32	TRAVEL CONCOURSE
33	TRAVEL CONCOURSE
34	TRAVEL CONCOURSE
35	TRAVEL CONCOURSE
36	TRAVEL CONCOURSE
37	TRAVEL CONCOURSE
38	TRAVEL CONCOURSE
39	TRAVEL CONCOURSE
40	TRAVEL CONCOURSE
41	TRAVEL CONCOURSE
42	TRAVEL CONCOURSE
43	TRAVEL CONCOURSE
44	TRAVEL CONCOURSE
45	TRAVEL CONCOURSE
46	TRAVEL CONCOURSE
47	TRAVEL CONCOURSE
48	TRAVEL CONCOURSE
49	TRAVEL CONCOURSE
50	TRAVEL CONCOURSE
51	TRAVEL CONCOURSE
52	TRAVEL CONCOURSE
53	TRAVEL CONCOURSE
54	TRAVEL CONCOURSE
55	TRAVEL CONCOURSE
56	TRAVEL CONCOURSE
57	TRAVEL CONCOURSE
58	TRAVEL CONCOURSE
59	TRAVEL CONCOURSE
60	TRAVEL CONCOURSE
61	TRAVEL CONCOURSE
62	TRAVEL CONCOURSE
63	TRAVEL CONCOURSE
64	TRAVEL CONCOURSE
65	TRAVEL CONCOURSE
66	TRAVEL CONCOURSE
67	TRAVEL CONCOURSE
68	TRAVEL CONCOURSE
69	TRAVEL CONCOURSE
70	TRAVEL CONCOURSE
71	TRAVEL CONCOURSE
72	TRAVEL CONCOURSE
73	TRAVEL CONCOURSE
74	TRAVEL CONCOURSE
75	TRAVEL CONCOURSE
76	TRAVEL CONCOURSE
77	TRAVEL CONCOURSE
78	TRAVEL CONCOURSE
79	TRAVEL CONCOURSE
80	TRAVEL CONCOURSE
81	TRAVEL CONCOURSE
82	TRAVEL CONCOURSE
83	TRAVEL CONCOURSE
84	TRAVEL CONCOURSE
85	TRAVEL CONCOURSE
86	TRAVEL CONCOURSE
87	TRAVEL CONCOURSE
88	TRAVEL CONCOURSE
89	TRAVEL CONCOURSE
90	TRAVEL CONCOURSE
91	TRAVEL CONCOURSE
92	TRAVEL CONCOURSE
93	TRAVEL CONCOURSE
94	TRAVEL CONCOURSE
95	TRAVEL CONCOURSE
96	TRAVEL CONCOURSE
97	TRAVEL CONCOURSE
98	TRAVEL CONCOURSE
99	TRAVEL CONCOURSE
100	TRAVEL CONCOURSE

MINNEAPOLIS/ST. PAUL  
 INTERNATIONAL AIRPORT  
 TERMINAL BUILDING  
 CONCOURSE F

FM110

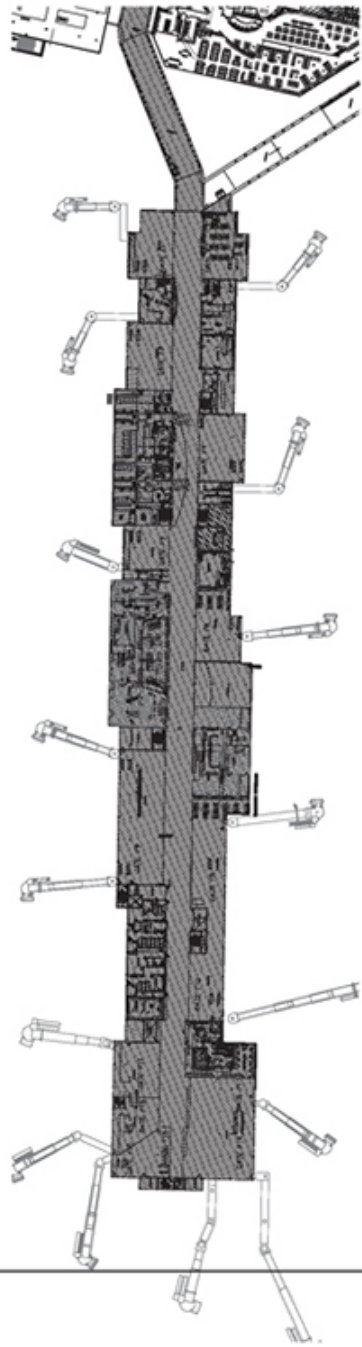

① MAIN LEVEL PLAN: CONCOURSE F

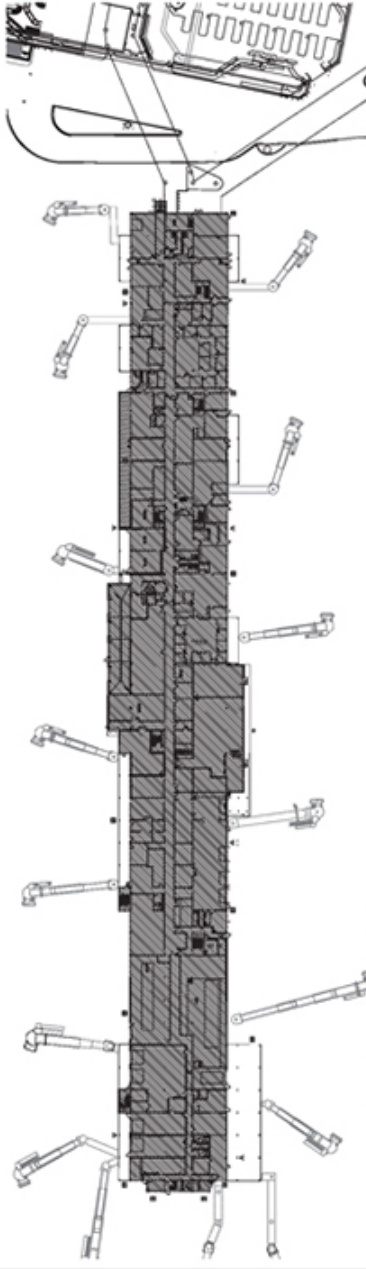

② GROUND LEVEL PLAN: CONCOURSE F

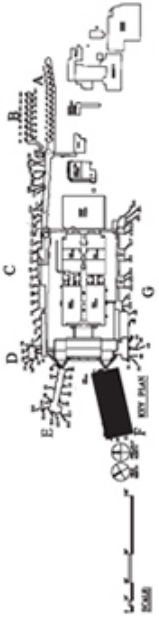



**EXHIBIT C**

Date : JANUARY 1, 2019  
 Page 11 of 28

LEGEND  
 TERMINAL BUILDING AREA



Metropolitan Airports Commission  
 6040 29th Avenue So.  
 Minneapolis, MN 55416



**Space Category Key**

1A	PUBLIC CONCOURSE
1B	PUBLIC CONCOURSE
1C	PUBLIC CONCOURSE
1D	PUBLIC CONCOURSE
1E	PUBLIC CONCOURSE
1F	PUBLIC CONCOURSE
1G	PUBLIC CONCOURSE
1H	PUBLIC CONCOURSE
1I	PUBLIC CONCOURSE
1J	PUBLIC CONCOURSE
1K	PUBLIC CONCOURSE
1L	PUBLIC CONCOURSE
1M	PUBLIC CONCOURSE
1N	PUBLIC CONCOURSE
1O	PUBLIC CONCOURSE
1P	PUBLIC CONCOURSE
1Q	PUBLIC CONCOURSE
1R	PUBLIC CONCOURSE
1S	PUBLIC CONCOURSE
1T	PUBLIC CONCOURSE
1U	PUBLIC CONCOURSE
1V	PUBLIC CONCOURSE
1W	PUBLIC CONCOURSE
1X	PUBLIC CONCOURSE
1Y	PUBLIC CONCOURSE
1Z	PUBLIC CONCOURSE
2A	NON-AIRLINE FOOD & BEVERAGE
2B	NON-AIRLINE FOOD & BEVERAGE
2C	NON-AIRLINE FOOD & BEVERAGE
2D	NON-AIRLINE FOOD & BEVERAGE
2E	NON-AIRLINE FOOD & BEVERAGE
2F	NON-AIRLINE FOOD & BEVERAGE
2G	NON-AIRLINE FOOD & BEVERAGE
2H	NON-AIRLINE FOOD & BEVERAGE
2I	NON-AIRLINE FOOD & BEVERAGE
2J	NON-AIRLINE FOOD & BEVERAGE
2K	NON-AIRLINE FOOD & BEVERAGE
2L	NON-AIRLINE FOOD & BEVERAGE
2M	NON-AIRLINE FOOD & BEVERAGE
2N	NON-AIRLINE FOOD & BEVERAGE
2O	NON-AIRLINE FOOD & BEVERAGE
2P	NON-AIRLINE FOOD & BEVERAGE
2Q	NON-AIRLINE FOOD & BEVERAGE
2R	NON-AIRLINE FOOD & BEVERAGE
2S	NON-AIRLINE FOOD & BEVERAGE
2T	NON-AIRLINE FOOD & BEVERAGE
2U	NON-AIRLINE FOOD & BEVERAGE
2V	NON-AIRLINE FOOD & BEVERAGE
2W	NON-AIRLINE FOOD & BEVERAGE
2X	NON-AIRLINE FOOD & BEVERAGE
2Y	NON-AIRLINE FOOD & BEVERAGE
2Z	NON-AIRLINE FOOD & BEVERAGE
3	ARRIVAL CONCOURSE
4	ARRIVAL CONCOURSE
5	ARRIVAL CONCOURSE
6	ARRIVAL CONCOURSE
7	ARRIVAL CONCOURSE
8	ARRIVAL CONCOURSE
9	ARRIVAL CONCOURSE
10	ARRIVAL CONCOURSE
11	ARRIVAL CONCOURSE
12	ARRIVAL CONCOURSE
13	ARRIVAL CONCOURSE
14	ARRIVAL CONCOURSE
15	ARRIVAL CONCOURSE
16	ARRIVAL CONCOURSE
17	ARRIVAL CONCOURSE
18	ARRIVAL CONCOURSE
19	ARRIVAL CONCOURSE
20	ARRIVAL CONCOURSE
21	ARRIVAL CONCOURSE
22	ARRIVAL CONCOURSE
23	ARRIVAL CONCOURSE
24	ARRIVAL CONCOURSE
25	ARRIVAL CONCOURSE
26	ARRIVAL CONCOURSE
27	ARRIVAL CONCOURSE
28	ARRIVAL CONCOURSE
29	ARRIVAL CONCOURSE
30	ARRIVAL CONCOURSE
31	ARRIVAL CONCOURSE
32	ARRIVAL CONCOURSE
33	ARRIVAL CONCOURSE
34	ARRIVAL CONCOURSE
35	ARRIVAL CONCOURSE
36	ARRIVAL CONCOURSE
37	ARRIVAL CONCOURSE
38	ARRIVAL CONCOURSE
39	ARRIVAL CONCOURSE
40	ARRIVAL CONCOURSE
41	ARRIVAL CONCOURSE
42	ARRIVAL CONCOURSE
43	ARRIVAL CONCOURSE
44	ARRIVAL CONCOURSE
45	ARRIVAL CONCOURSE
46	ARRIVAL CONCOURSE
47	ARRIVAL CONCOURSE
48	ARRIVAL CONCOURSE
49	ARRIVAL CONCOURSE
50	ARRIVAL CONCOURSE
51	ARRIVAL CONCOURSE
52	ARRIVAL CONCOURSE
53	ARRIVAL CONCOURSE
54	ARRIVAL CONCOURSE
55	ARRIVAL CONCOURSE
56	ARRIVAL CONCOURSE
57	ARRIVAL CONCOURSE
58	ARRIVAL CONCOURSE
59	ARRIVAL CONCOURSE
60	ARRIVAL CONCOURSE
61	ARRIVAL CONCOURSE
62	ARRIVAL CONCOURSE
63	ARRIVAL CONCOURSE
64	ARRIVAL CONCOURSE
65	ARRIVAL CONCOURSE
66	ARRIVAL CONCOURSE
67	ARRIVAL CONCOURSE
68	ARRIVAL CONCOURSE
69	ARRIVAL CONCOURSE
70	ARRIVAL CONCOURSE
71	ARRIVAL CONCOURSE
72	ARRIVAL CONCOURSE
73	ARRIVAL CONCOURSE
74	ARRIVAL CONCOURSE
75	ARRIVAL CONCOURSE
76	ARRIVAL CONCOURSE
77	ARRIVAL CONCOURSE
78	ARRIVAL CONCOURSE
79	ARRIVAL CONCOURSE
80	ARRIVAL CONCOURSE
81	ARRIVAL CONCOURSE
82	ARRIVAL CONCOURSE
83	ARRIVAL CONCOURSE
84	ARRIVAL CONCOURSE
85	ARRIVAL CONCOURSE
86	ARRIVAL CONCOURSE
87	ARRIVAL CONCOURSE
88	ARRIVAL CONCOURSE
89	ARRIVAL CONCOURSE
90	ARRIVAL CONCOURSE
91	ARRIVAL CONCOURSE
92	ARRIVAL CONCOURSE
93	ARRIVAL CONCOURSE
94	ARRIVAL CONCOURSE
95	ARRIVAL CONCOURSE
96	ARRIVAL CONCOURSE
97	ARRIVAL CONCOURSE
98	ARRIVAL CONCOURSE
99	ARRIVAL CONCOURSE
100	ARRIVAL CONCOURSE

MINNEAPOLIS / ST. PAUL INTERNATIONAL AIRPORT  
**TERMINAL BUILDING**  
 CONTOUR CONTOUR B

FM112

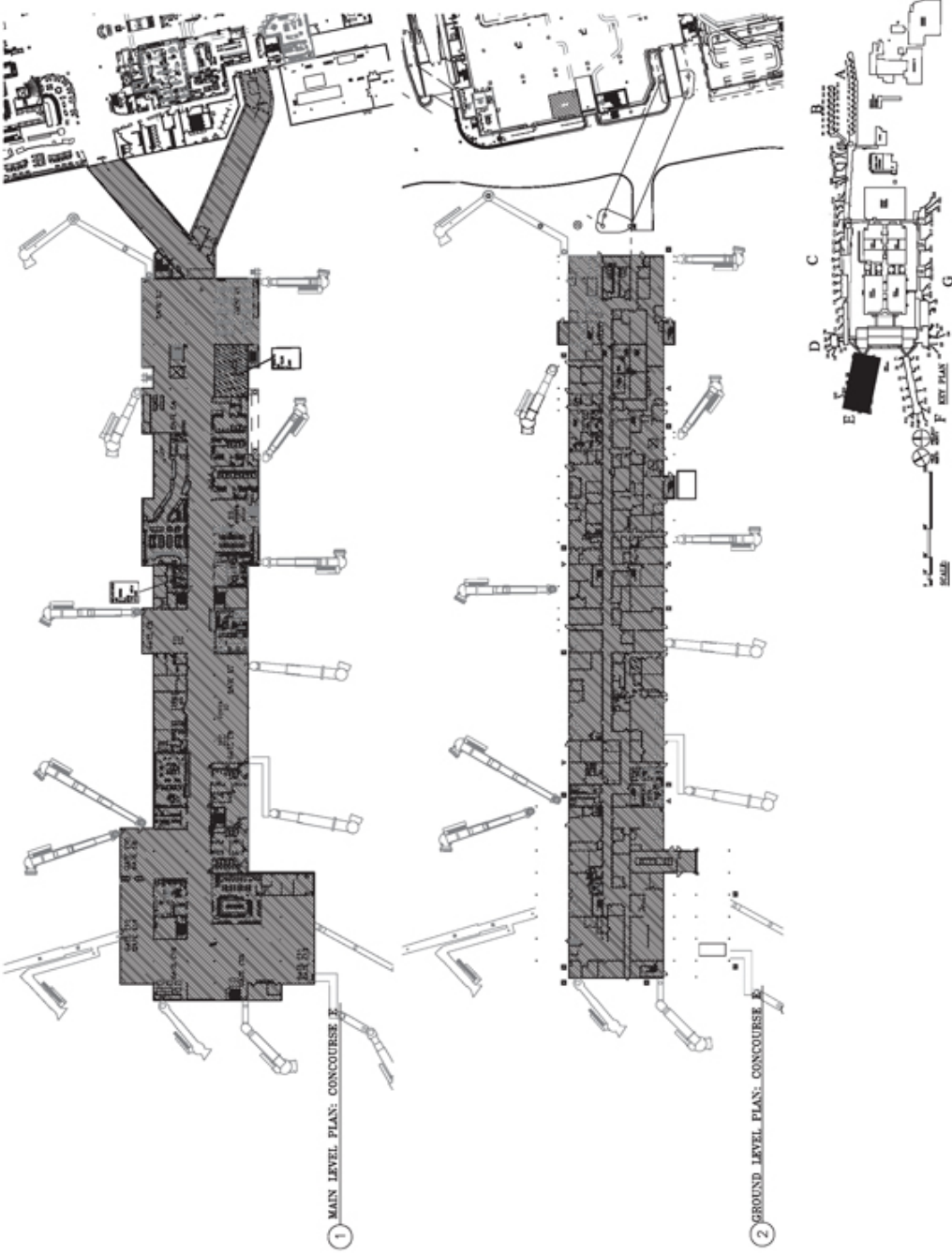

# EXHIBIT C

Date : JANUARY 1, 2019  
 Page 12 of 28

LEGEND  
 TERMINAL BUILDING  
 AREA



Metropolitan  
 Airports  
 Commission  
 6040 29th Avenue So.  
 Minneapolis, MN 55416

Space Category Key

1	TRAVEL NAME
2	TRAVEL
3	TRAVEL
4	TRAVEL
5	TRAVEL
6	TRAVEL
7	TRAVEL
8	TRAVEL
9	TRAVEL
10	TRAVEL
11	TRAVEL
12	TRAVEL
13	TRAVEL
14	TRAVEL
15	TRAVEL
16	TRAVEL
17	TRAVEL
18	TRAVEL
19	TRAVEL
20	TRAVEL
21	TRAVEL
22	TRAVEL
23	TRAVEL
24	TRAVEL
25	TRAVEL
26	TRAVEL
27	TRAVEL
28	TRAVEL
29	TRAVEL
30	TRAVEL
31	TRAVEL
32	TRAVEL
33	TRAVEL
34	TRAVEL
35	TRAVEL
36	TRAVEL
37	TRAVEL
38	TRAVEL
39	TRAVEL
40	TRAVEL
41	TRAVEL
42	TRAVEL
43	TRAVEL
44	TRAVEL
45	TRAVEL
46	TRAVEL
47	TRAVEL
48	TRAVEL
49	TRAVEL
50	TRAVEL
51	TRAVEL
52	TRAVEL
53	TRAVEL
54	TRAVEL
55	TRAVEL
56	TRAVEL
57	TRAVEL
58	TRAVEL
59	TRAVEL
60	TRAVEL
61	TRAVEL
62	TRAVEL
63	TRAVEL
64	TRAVEL
65	TRAVEL
66	TRAVEL
67	TRAVEL
68	TRAVEL
69	TRAVEL
70	TRAVEL
71	TRAVEL
72	TRAVEL
73	TRAVEL
74	TRAVEL
75	TRAVEL
76	TRAVEL
77	TRAVEL
78	TRAVEL
79	TRAVEL
80	TRAVEL
81	TRAVEL
82	TRAVEL
83	TRAVEL
84	TRAVEL
85	TRAVEL
86	TRAVEL
87	TRAVEL
88	TRAVEL
89	TRAVEL
90	TRAVEL
91	TRAVEL
92	TRAVEL
93	TRAVEL
94	TRAVEL
95	TRAVEL
96	TRAVEL
97	TRAVEL
98	TRAVEL
99	TRAVEL
100	TRAVEL

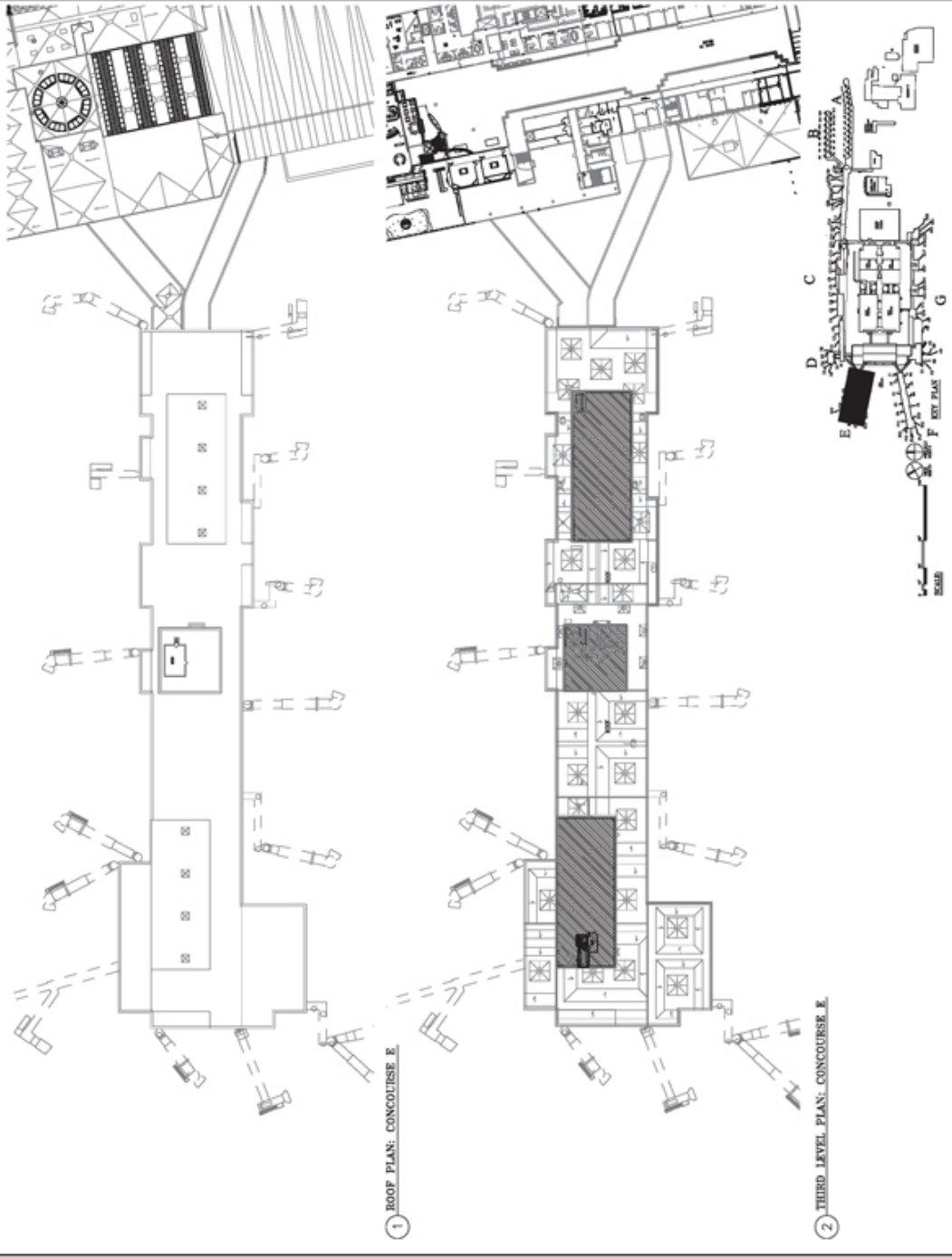

1 ROOF PLAN: CONCOURSE E

2 THIRD LEVEL PLAN: CONCOURSE E





# EXHIBIT C

Date : JANUARY 1, 2019  
 Page 14 of 28

LEGEND  
 TERMINAL BUILDING AREA



Metropolitan Airports Commission  
 6040 29th Avenue So.  
 Minneapolis, MN 55410

MIN IN SQUARE FEET

SYMBOL	SPACE NAME
1	TRAVEL
2	TRAVEL
3	TRAVEL
4	TRAVEL
5	TRAVEL
6	TRAVEL
7	TRAVEL
8	TRAVEL
9	TRAVEL
10	TRAVEL
11	TRAVEL
12	TRAVEL
13	TRAVEL
14	TRAVEL
15	TRAVEL
16	TRAVEL
17	TRAVEL
18	TRAVEL
19	TRAVEL
20	TRAVEL
21	TRAVEL
22	TRAVEL
23	TRAVEL
24	TRAVEL
25	TRAVEL
26	TRAVEL
27	TRAVEL
28	TRAVEL
29	TRAVEL
30	TRAVEL
31	TRAVEL
32	TRAVEL
33	TRAVEL
34	TRAVEL
35	TRAVEL
36	TRAVEL
37	TRAVEL
38	TRAVEL
39	TRAVEL
40	TRAVEL
41	TRAVEL
42	TRAVEL
43	TRAVEL
44	TRAVEL
45	TRAVEL
46	TRAVEL
47	TRAVEL
48	TRAVEL
49	TRAVEL
50	TRAVEL
51	TRAVEL
52	TRAVEL
53	TRAVEL
54	TRAVEL
55	TRAVEL
56	TRAVEL
57	TRAVEL
58	TRAVEL
59	TRAVEL
60	TRAVEL
61	TRAVEL
62	TRAVEL
63	TRAVEL
64	TRAVEL
65	TRAVEL
66	TRAVEL
67	TRAVEL
68	TRAVEL
69	TRAVEL
70	TRAVEL
71	TRAVEL
72	TRAVEL
73	TRAVEL
74	TRAVEL
75	TRAVEL
76	TRAVEL
77	TRAVEL
78	TRAVEL
79	TRAVEL
80	TRAVEL
81	TRAVEL
82	TRAVEL
83	TRAVEL
84	TRAVEL
85	TRAVEL
86	TRAVEL
87	TRAVEL
88	TRAVEL
89	TRAVEL
90	TRAVEL
91	TRAVEL
92	TRAVEL
93	TRAVEL
94	TRAVEL
95	TRAVEL
96	TRAVEL
97	TRAVEL
98	TRAVEL
99	TRAVEL
100	TRAVEL

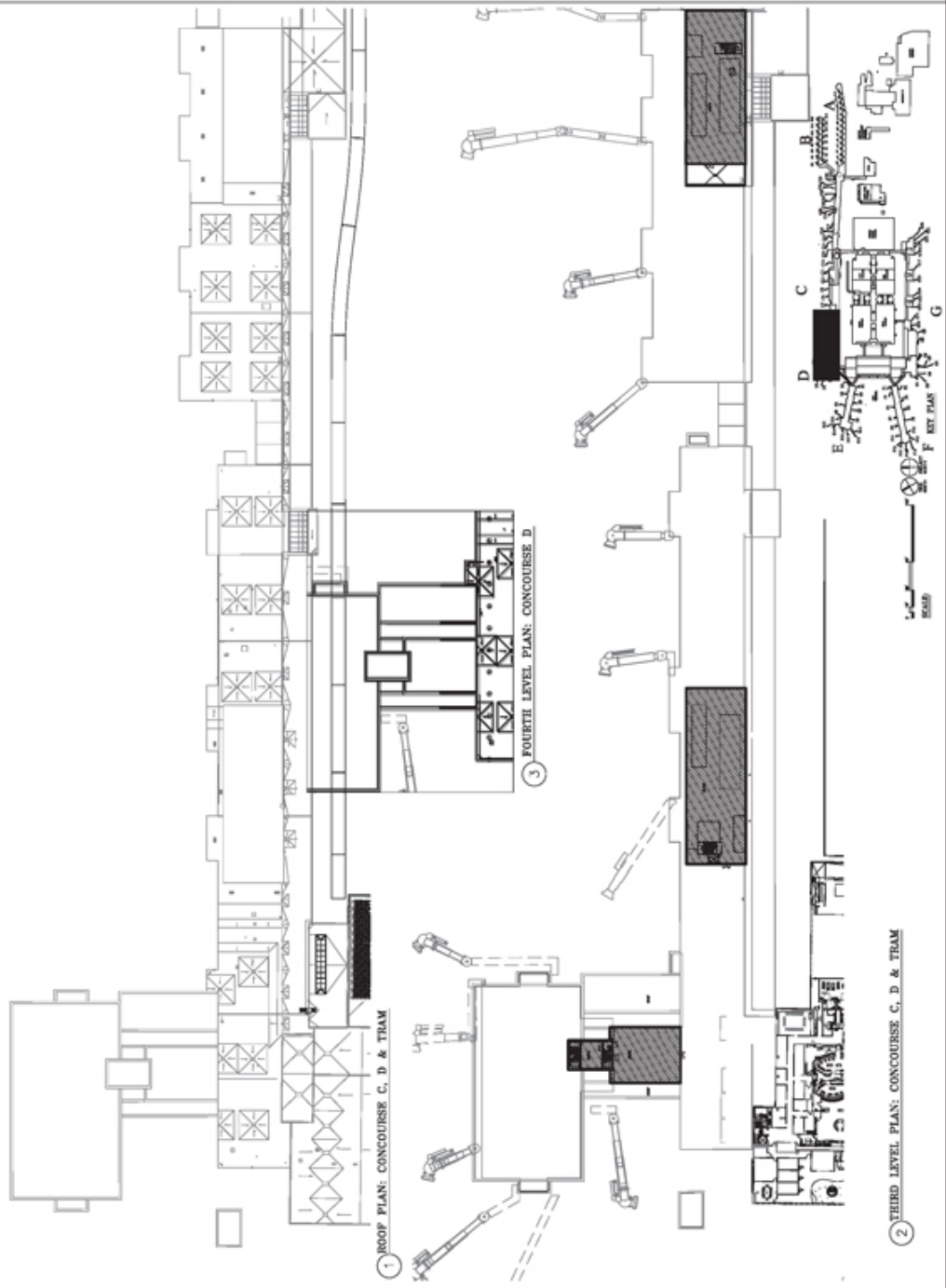

2 THIRD LEVEL PLAN: CONCOURSE C, D & TRAIN

3 FOURTH LEVEL PLAN: CONCOURSE D

1 ROOF PLAN: CONCOURSE C, D & TRAIN

MINNEAPOLIS / ST. PAUL INTERNATIONAL AIRPORT  
 TERMINAL BUILDING  
 CONCOURSE C - D  
 FM116

# EXHIBIT C

Date : JANUARY 1, 2019  
 Page 15 of 28

LEGEND  
 TERMINAL BUILDING AREA



Metropolitan  
 Airports  
 Commission  
 6040 29th Avenue So.  
 Minneapolis, MN 55410

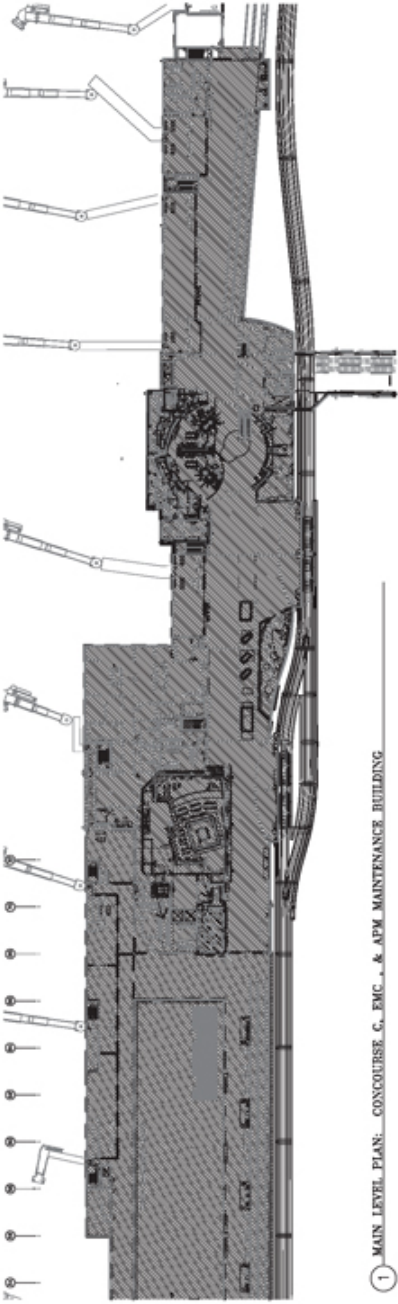

① MAIN LEVEL PLAN: CONCOURSE C, EMC, & APM MAINTENANCE BUILDING

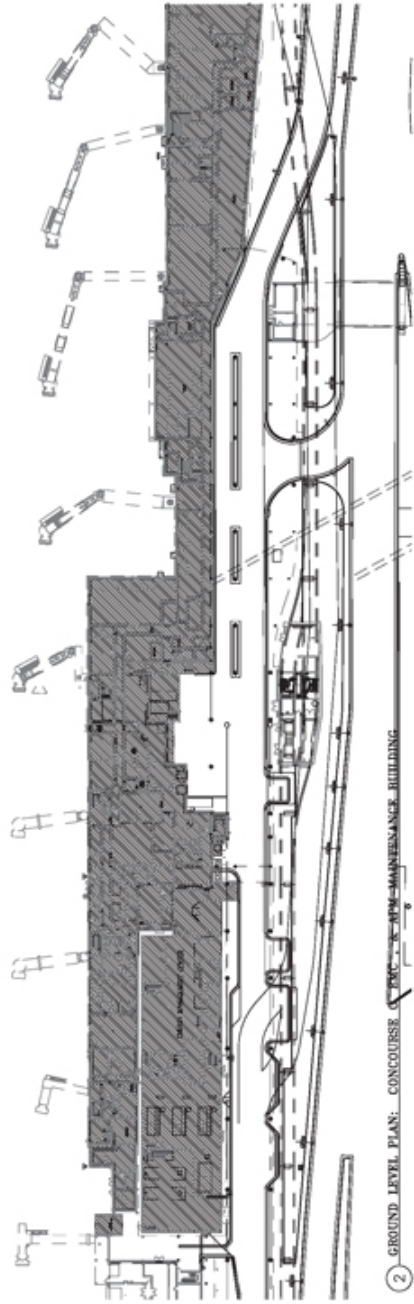

② GROUND LEVEL PLAN: CONCOURSE C, EMC, & APM MAINTENANCE BUILDING



## Space Category Key

- 1A PUBLIC LOBBY
- 1B PUBLIC LOBBY
- 1C PUBLIC LOBBY
- 1D PUBLIC LOBBY
- 1E PUBLIC LOBBY
- 1F PUBLIC LOBBY
- 1G PUBLIC LOBBY
- 1H PUBLIC LOBBY
- 1I PUBLIC LOBBY
- 1J PUBLIC LOBBY
- 1K PUBLIC LOBBY
- 1L PUBLIC LOBBY
- 1M PUBLIC LOBBY
- 1N PUBLIC LOBBY
- 1O PUBLIC LOBBY
- 1P PUBLIC LOBBY
- 1Q PUBLIC LOBBY
- 1R PUBLIC LOBBY
- 1S PUBLIC LOBBY
- 1T PUBLIC LOBBY
- 1U PUBLIC LOBBY
- 1V PUBLIC LOBBY
- 1W PUBLIC LOBBY
- 1X PUBLIC LOBBY
- 1Y PUBLIC LOBBY
- 1Z PUBLIC LOBBY
- 2A PUBLIC LOBBY
- 2B PUBLIC LOBBY
- 2C PUBLIC LOBBY
- 2D PUBLIC LOBBY
- 2E PUBLIC LOBBY
- 2F PUBLIC LOBBY
- 2G PUBLIC LOBBY
- 2H PUBLIC LOBBY
- 2I PUBLIC LOBBY
- 2J PUBLIC LOBBY
- 2K PUBLIC LOBBY
- 2L PUBLIC LOBBY
- 2M PUBLIC LOBBY
- 2N PUBLIC LOBBY
- 2O PUBLIC LOBBY
- 2P PUBLIC LOBBY
- 2Q PUBLIC LOBBY
- 2R PUBLIC LOBBY
- 2S PUBLIC LOBBY
- 2T PUBLIC LOBBY
- 2U PUBLIC LOBBY
- 2V PUBLIC LOBBY
- 2W PUBLIC LOBBY
- 2X PUBLIC LOBBY
- 2Y PUBLIC LOBBY
- 2Z PUBLIC LOBBY
- 3A PUBLIC LOBBY
- 3B PUBLIC LOBBY
- 3C PUBLIC LOBBY
- 3D PUBLIC LOBBY
- 3E PUBLIC LOBBY
- 3F PUBLIC LOBBY
- 3G PUBLIC LOBBY
- 3H PUBLIC LOBBY
- 3I PUBLIC LOBBY
- 3J PUBLIC LOBBY
- 3K PUBLIC LOBBY
- 3L PUBLIC LOBBY
- 3M PUBLIC LOBBY
- 3N PUBLIC LOBBY
- 3O PUBLIC LOBBY
- 3P PUBLIC LOBBY
- 3Q PUBLIC LOBBY
- 3R PUBLIC LOBBY
- 3S PUBLIC LOBBY
- 3T PUBLIC LOBBY
- 3U PUBLIC LOBBY
- 3V PUBLIC LOBBY
- 3W PUBLIC LOBBY
- 3X PUBLIC LOBBY
- 3Y PUBLIC LOBBY
- 3Z PUBLIC LOBBY
- 4A PUBLIC LOBBY
- 4B PUBLIC LOBBY
- 4C PUBLIC LOBBY
- 4D PUBLIC LOBBY
- 4E PUBLIC LOBBY
- 4F PUBLIC LOBBY
- 4G PUBLIC LOBBY
- 4H PUBLIC LOBBY
- 4I PUBLIC LOBBY
- 4J PUBLIC LOBBY
- 4K PUBLIC LOBBY
- 4L PUBLIC LOBBY
- 4M PUBLIC LOBBY
- 4N PUBLIC LOBBY
- 4O PUBLIC LOBBY
- 4P PUBLIC LOBBY
- 4Q PUBLIC LOBBY
- 4R PUBLIC LOBBY
- 4S PUBLIC LOBBY
- 4T PUBLIC LOBBY
- 4U PUBLIC LOBBY
- 4V PUBLIC LOBBY
- 4W PUBLIC LOBBY
- 4X PUBLIC LOBBY
- 4Y PUBLIC LOBBY
- 4Z PUBLIC LOBBY
- 5A PUBLIC LOBBY
- 5B PUBLIC LOBBY
- 5C PUBLIC LOBBY
- 5D PUBLIC LOBBY
- 5E PUBLIC LOBBY
- 5F PUBLIC LOBBY
- 5G PUBLIC LOBBY
- 5H PUBLIC LOBBY
- 5I PUBLIC LOBBY
- 5J PUBLIC LOBBY
- 5K PUBLIC LOBBY
- 5L PUBLIC LOBBY
- 5M PUBLIC LOBBY
- 5N PUBLIC LOBBY
- 5O PUBLIC LOBBY
- 5P PUBLIC LOBBY
- 5Q PUBLIC LOBBY
- 5R PUBLIC LOBBY
- 5S PUBLIC LOBBY
- 5T PUBLIC LOBBY
- 5U PUBLIC LOBBY
- 5V PUBLIC LOBBY
- 5W PUBLIC LOBBY
- 5X PUBLIC LOBBY
- 5Y PUBLIC LOBBY
- 5Z PUBLIC LOBBY
- 6A PUBLIC LOBBY
- 6B PUBLIC LOBBY
- 6C PUBLIC LOBBY
- 6D PUBLIC LOBBY
- 6E PUBLIC LOBBY
- 6F PUBLIC LOBBY
- 6G PUBLIC LOBBY
- 6H PUBLIC LOBBY
- 6I PUBLIC LOBBY
- 6J PUBLIC LOBBY
- 6K PUBLIC LOBBY
- 6L PUBLIC LOBBY
- 6M PUBLIC LOBBY
- 6N PUBLIC LOBBY
- 6O PUBLIC LOBBY
- 6P PUBLIC LOBBY
- 6Q PUBLIC LOBBY
- 6R PUBLIC LOBBY
- 6S PUBLIC LOBBY
- 6T PUBLIC LOBBY
- 6U PUBLIC LOBBY
- 6V PUBLIC LOBBY
- 6W PUBLIC LOBBY
- 6X PUBLIC LOBBY
- 6Y PUBLIC LOBBY
- 6Z PUBLIC LOBBY
- 7A PUBLIC LOBBY
- 7B PUBLIC LOBBY
- 7C PUBLIC LOBBY
- 7D PUBLIC LOBBY
- 7E PUBLIC LOBBY
- 7F PUBLIC LOBBY
- 7G PUBLIC LOBBY
- 7H PUBLIC LOBBY
- 7I PUBLIC LOBBY
- 7J PUBLIC LOBBY
- 7K PUBLIC LOBBY
- 7L PUBLIC LOBBY
- 7M PUBLIC LOBBY
- 7N PUBLIC LOBBY
- 7O PUBLIC LOBBY
- 7P PUBLIC LOBBY
- 7Q PUBLIC LOBBY
- 7R PUBLIC LOBBY
- 7S PUBLIC LOBBY
- 7T PUBLIC LOBBY
- 7U PUBLIC LOBBY
- 7V PUBLIC LOBBY
- 7W PUBLIC LOBBY
- 7X PUBLIC LOBBY
- 7Y PUBLIC LOBBY
- 7Z PUBLIC LOBBY
- 8A PUBLIC LOBBY
- 8B PUBLIC LOBBY
- 8C PUBLIC LOBBY
- 8D PUBLIC LOBBY
- 8E PUBLIC LOBBY
- 8F PUBLIC LOBBY
- 8G PUBLIC LOBBY
- 8H PUBLIC LOBBY
- 8I PUBLIC LOBBY
- 8J PUBLIC LOBBY
- 8K PUBLIC LOBBY
- 8L PUBLIC LOBBY
- 8M PUBLIC LOBBY
- 8N PUBLIC LOBBY
- 8O PUBLIC LOBBY
- 8P PUBLIC LOBBY
- 8Q PUBLIC LOBBY
- 8R PUBLIC LOBBY
- 8S PUBLIC LOBBY
- 8T PUBLIC LOBBY
- 8U PUBLIC LOBBY
- 8V PUBLIC LOBBY
- 8W PUBLIC LOBBY
- 8X PUBLIC LOBBY
- 8Y PUBLIC LOBBY
- 8Z PUBLIC LOBBY
- 9A PUBLIC LOBBY
- 9B PUBLIC LOBBY
- 9C PUBLIC LOBBY
- 9D PUBLIC LOBBY
- 9E PUBLIC LOBBY
- 9F PUBLIC LOBBY
- 9G PUBLIC LOBBY
- 9H PUBLIC LOBBY
- 9I PUBLIC LOBBY
- 9J PUBLIC LOBBY
- 9K PUBLIC LOBBY
- 9L PUBLIC LOBBY
- 9M PUBLIC LOBBY
- 9N PUBLIC LOBBY
- 9O PUBLIC LOBBY
- 9P PUBLIC LOBBY
- 9Q PUBLIC LOBBY
- 9R PUBLIC LOBBY
- 9S PUBLIC LOBBY
- 9T PUBLIC LOBBY
- 9U PUBLIC LOBBY
- 9V PUBLIC LOBBY
- 9W PUBLIC LOBBY
- 9X PUBLIC LOBBY
- 9Y PUBLIC LOBBY
- 9Z PUBLIC LOBBY
- 10A PUBLIC LOBBY
- 10B PUBLIC LOBBY
- 10C PUBLIC LOBBY
- 10D PUBLIC LOBBY
- 10E PUBLIC LOBBY
- 10F PUBLIC LOBBY
- 10G PUBLIC LOBBY
- 10H PUBLIC LOBBY
- 10I PUBLIC LOBBY
- 10J PUBLIC LOBBY
- 10K PUBLIC LOBBY
- 10L PUBLIC LOBBY
- 10M PUBLIC LOBBY
- 10N PUBLIC LOBBY
- 10O PUBLIC LOBBY
- 10P PUBLIC LOBBY
- 10Q PUBLIC LOBBY
- 10R PUBLIC LOBBY
- 10S PUBLIC LOBBY
- 10T PUBLIC LOBBY
- 10U PUBLIC LOBBY
- 10V PUBLIC LOBBY
- 10W PUBLIC LOBBY
- 10X PUBLIC LOBBY
- 10Y PUBLIC LOBBY
- 10Z PUBLIC LOBBY

MINNEAPOLIS / ST. PAUL  
 INTERNATIONAL AIRPORT  
 TERMINAL BUILDING  
 CONCOURSE C



# EXHIBIT C

Date : JANUARY 1, 2019  
 Page 16 of 28

LEGEND  
 TERMINAL BUILDING AREA



Metropolitan Airports Commission  
 6040 29th Avenue So.  
 Minneapolis, MN 55416



**Space Category Key**

1A	PUBLIC LOBBY/RECEPTION
1B	ARRIVAL CONCOURSE
1C	TRAVEL CONCOURSE
1D	ARRIVAL CONCOURSE
1E	ARRIVAL CONCOURSE
1F	ARRIVAL CONCOURSE
1G	ARRIVAL CONCOURSE
1H	ARRIVAL CONCOURSE
1I	ARRIVAL CONCOURSE
1J	ARRIVAL CONCOURSE
1K	ARRIVAL CONCOURSE
1L	ARRIVAL CONCOURSE
1M	ARRIVAL CONCOURSE
1N	ARRIVAL CONCOURSE
1O	ARRIVAL CONCOURSE
1P	ARRIVAL CONCOURSE
1Q	ARRIVAL CONCOURSE
1R	ARRIVAL CONCOURSE
1S	ARRIVAL CONCOURSE
1T	ARRIVAL CONCOURSE
1U	ARRIVAL CONCOURSE
1V	ARRIVAL CONCOURSE
1W	ARRIVAL CONCOURSE
1X	ARRIVAL CONCOURSE
1Y	ARRIVAL CONCOURSE
1Z	ARRIVAL CONCOURSE
2A	MEZZANINE
2B	MEZZANINE
2C	MEZZANINE
2D	MEZZANINE
2E	MEZZANINE
2F	MEZZANINE
2G	MEZZANINE
2H	MEZZANINE
2I	MEZZANINE
2J	MEZZANINE
2K	MEZZANINE
2L	MEZZANINE
2M	MEZZANINE
2N	MEZZANINE
2O	MEZZANINE
2P	MEZZANINE
2Q	MEZZANINE
2R	MEZZANINE
2S	MEZZANINE
2T	MEZZANINE
2U	MEZZANINE
2V	MEZZANINE
2W	MEZZANINE
2X	MEZZANINE
2Y	MEZZANINE
2Z	MEZZANINE
3A	PENTHOUSE
3B	PENTHOUSE
3C	PENTHOUSE
3D	PENTHOUSE
3E	PENTHOUSE
3F	PENTHOUSE
3G	PENTHOUSE
3H	PENTHOUSE
3I	PENTHOUSE
3J	PENTHOUSE
3K	PENTHOUSE
3L	PENTHOUSE
3M	PENTHOUSE
3N	PENTHOUSE
3O	PENTHOUSE
3P	PENTHOUSE
3Q	PENTHOUSE
3R	PENTHOUSE
3S	PENTHOUSE
3T	PENTHOUSE
3U	PENTHOUSE
3V	PENTHOUSE
3W	PENTHOUSE
3X	PENTHOUSE
3Y	PENTHOUSE
3Z	PENTHOUSE

MINNEAPOLIS / ST. PAUL INTERNATIONAL AIRPORT  
**TERMINAL BUILDING**  
 CONTOUR CONTOUR C

FM1.20

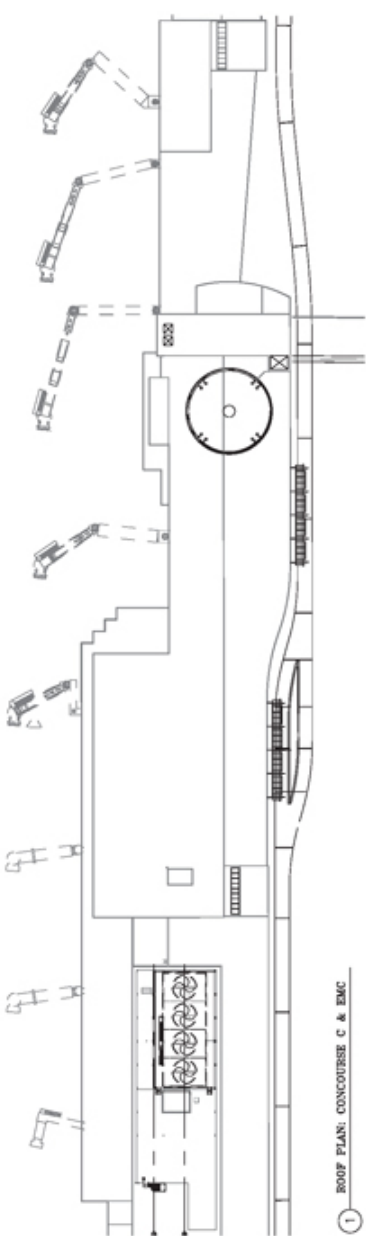

1 ROOF PLAN: CONCOURSE C & EMC

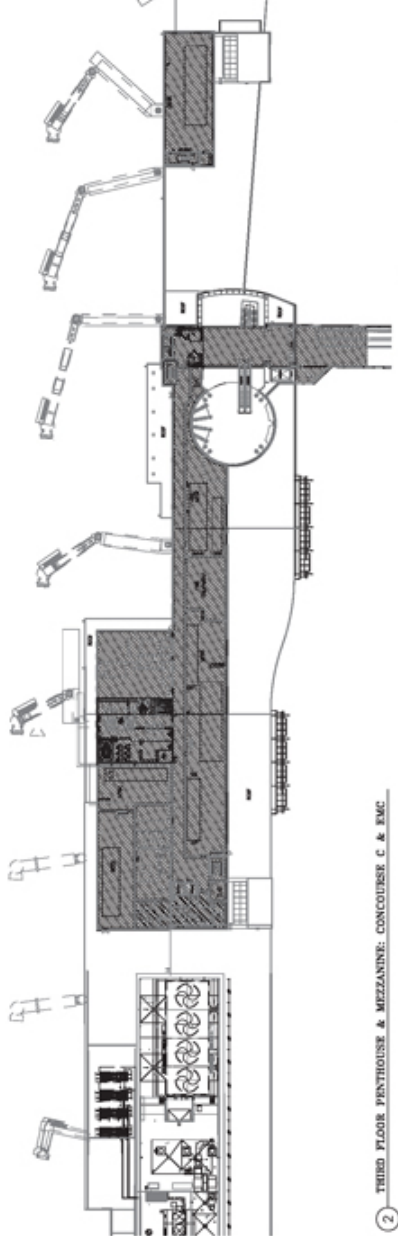

2 THIRD FLOOR PENTHOUSE & MEZZANINE: CONCOURSE C & EMC

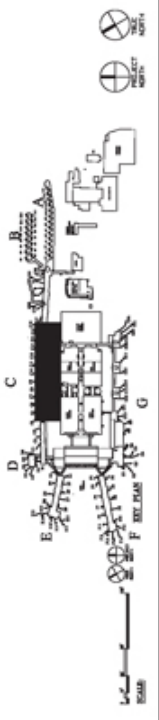



# EXHIBIT C

Date : JANUARY 1, 2019  
 Page 18 of 28

LEGEND  
 TERMINAL BUILDING AREA



Metropolitan Airports Commission  
 6040 29th Avenue So.  
 Minneapolis, MN 55416

Space Category Key

10	TRAVEL WAIT
11	TRAVEL CATEGORY
12	TRAVEL WAIT
13	TRAVEL WAIT
14	TRAVEL WAIT
15	TRAVEL WAIT
16	TRAVEL WAIT
17	TRAVEL WAIT
18	TRAVEL WAIT
19	TRAVEL WAIT
20	TRAVEL WAIT
21	TRAVEL WAIT
22	TRAVEL WAIT
23	TRAVEL WAIT
24	TRAVEL WAIT
25	TRAVEL WAIT
26	TRAVEL WAIT
27	TRAVEL WAIT
28	TRAVEL WAIT
29	TRAVEL WAIT
30	TRAVEL WAIT
31	TRAVEL WAIT
32	TRAVEL WAIT
33	TRAVEL WAIT
34	TRAVEL WAIT
35	TRAVEL WAIT
36	TRAVEL WAIT
37	TRAVEL WAIT
38	TRAVEL WAIT
39	TRAVEL WAIT
40	TRAVEL WAIT
41	TRAVEL WAIT
42	TRAVEL WAIT
43	TRAVEL WAIT
44	TRAVEL WAIT
45	TRAVEL WAIT
46	TRAVEL WAIT
47	TRAVEL WAIT
48	TRAVEL WAIT
49	TRAVEL WAIT
50	TRAVEL WAIT
51	TRAVEL WAIT
52	TRAVEL WAIT
53	TRAVEL WAIT
54	TRAVEL WAIT
55	TRAVEL WAIT
56	TRAVEL WAIT
57	TRAVEL WAIT
58	TRAVEL WAIT
59	TRAVEL WAIT
60	TRAVEL WAIT
61	TRAVEL WAIT
62	TRAVEL WAIT
63	TRAVEL WAIT
64	TRAVEL WAIT
65	TRAVEL WAIT
66	TRAVEL WAIT
67	TRAVEL WAIT
68	TRAVEL WAIT
69	TRAVEL WAIT
70	TRAVEL WAIT
71	TRAVEL WAIT
72	TRAVEL WAIT
73	TRAVEL WAIT
74	TRAVEL WAIT
75	TRAVEL WAIT
76	TRAVEL WAIT
77	TRAVEL WAIT
78	TRAVEL WAIT
79	TRAVEL WAIT
80	TRAVEL WAIT
81	TRAVEL WAIT
82	TRAVEL WAIT
83	TRAVEL WAIT
84	TRAVEL WAIT
85	TRAVEL WAIT
86	TRAVEL WAIT
87	TRAVEL WAIT
88	TRAVEL WAIT
89	TRAVEL WAIT
90	TRAVEL WAIT
91	TRAVEL WAIT
92	TRAVEL WAIT
93	TRAVEL WAIT
94	TRAVEL WAIT
95	TRAVEL WAIT
96	TRAVEL WAIT
97	TRAVEL WAIT
98	TRAVEL WAIT
99	TRAVEL WAIT
100	TRAVEL WAIT

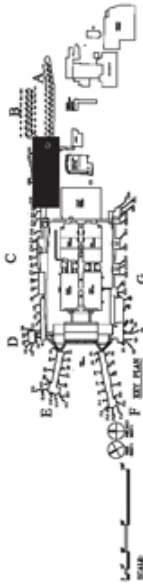
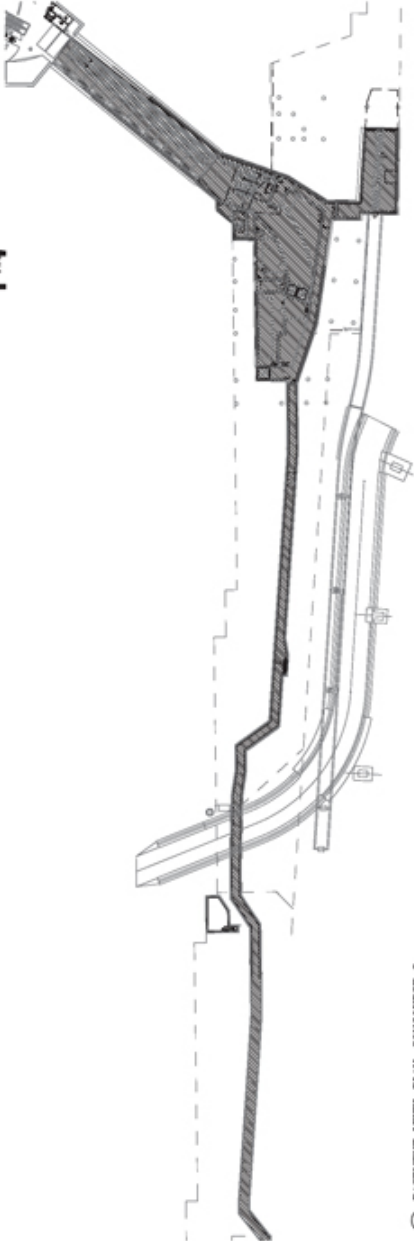
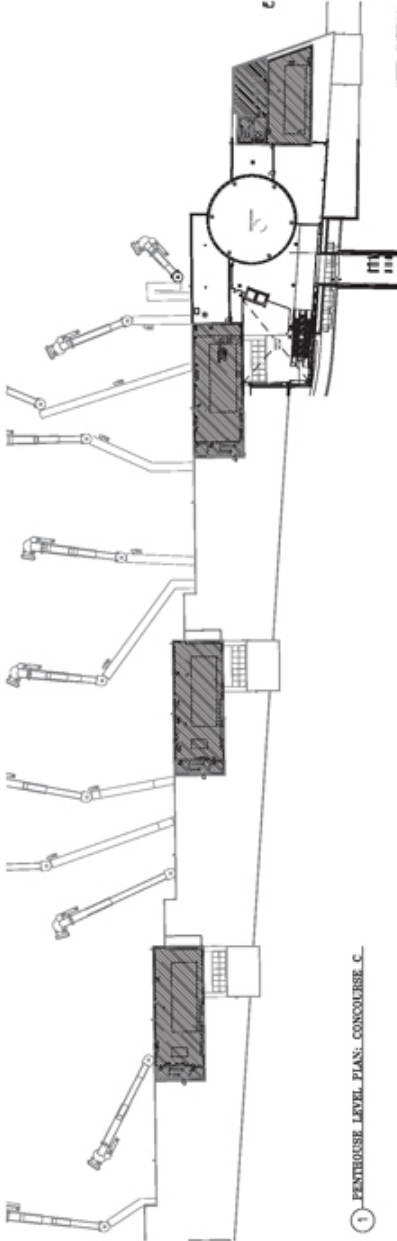

# EXHIBIT C

Date : JANUARY 1, 2019  
 Page 19 of 28

LEGEND  
 TERMINAL BUILDING AREA



Metropolitan Airports Commission  
 6040 29th Avenue So.  
 Minneapolis, MN 55416

Space Category Key

KEY	SPACE NAME
1	TRAVEL
2	SPACE OUTDOOR
3	SHOW NUMBER
4	NON-ADJACENT
5	OR ADJACENT
6	SEE IN TOURER VIEW
1A	PUBLIC LOBBY
1B	PUBLIC LOBBY
1C	PUBLIC LOBBY
1D	PUBLIC LOBBY
1E	PUBLIC LOBBY
1F	PUBLIC LOBBY
1G	PUBLIC LOBBY
1H	PUBLIC LOBBY
1I	PUBLIC LOBBY
1J	PUBLIC LOBBY
1K	PUBLIC LOBBY
1L	PUBLIC LOBBY
1M	PUBLIC LOBBY
1N	PUBLIC LOBBY
1O	PUBLIC LOBBY
1P	PUBLIC LOBBY
1Q	PUBLIC LOBBY
1R	PUBLIC LOBBY
1S	PUBLIC LOBBY
1T	PUBLIC LOBBY
1U	PUBLIC LOBBY
1V	PUBLIC LOBBY
1W	PUBLIC LOBBY
1X	PUBLIC LOBBY
1Y	PUBLIC LOBBY
1Z	PUBLIC LOBBY
2A	NON-ADJACENT
2B	NON-ADJACENT
2C	NON-ADJACENT
2D	NON-ADJACENT
2E	NON-ADJACENT
2F	NON-ADJACENT
2G	NON-ADJACENT
2H	NON-ADJACENT
2I	NON-ADJACENT
2J	NON-ADJACENT
2K	NON-ADJACENT
2L	NON-ADJACENT
2M	NON-ADJACENT
2N	NON-ADJACENT
2O	NON-ADJACENT
2P	NON-ADJACENT
2Q	NON-ADJACENT
2R	NON-ADJACENT
2S	NON-ADJACENT
2T	NON-ADJACENT
2U	NON-ADJACENT
2V	NON-ADJACENT
2W	NON-ADJACENT
2X	NON-ADJACENT
2Y	NON-ADJACENT
2Z	NON-ADJACENT
3A	NON-ADJACENT
3B	NON-ADJACENT
3C	NON-ADJACENT
3D	NON-ADJACENT
3E	NON-ADJACENT
3F	NON-ADJACENT
3G	NON-ADJACENT
3H	NON-ADJACENT
3I	NON-ADJACENT
3J	NON-ADJACENT
3K	NON-ADJACENT
3L	NON-ADJACENT
3M	NON-ADJACENT
3N	NON-ADJACENT
3O	NON-ADJACENT
3P	NON-ADJACENT
3Q	NON-ADJACENT
3R	NON-ADJACENT
3S	NON-ADJACENT
3T	NON-ADJACENT
3U	NON-ADJACENT
3V	NON-ADJACENT
3W	NON-ADJACENT
3X	NON-ADJACENT
3Y	NON-ADJACENT
3Z	NON-ADJACENT
4A	NON-ADJACENT
4B	NON-ADJACENT
4C	NON-ADJACENT
4D	NON-ADJACENT
4E	NON-ADJACENT
4F	NON-ADJACENT
4G	NON-ADJACENT
4H	NON-ADJACENT
4I	NON-ADJACENT
4J	NON-ADJACENT
4K	NON-ADJACENT
4L	NON-ADJACENT
4M	NON-ADJACENT
4N	NON-ADJACENT
4O	NON-ADJACENT
4P	NON-ADJACENT
4Q	NON-ADJACENT
4R	NON-ADJACENT
4S	NON-ADJACENT
4T	NON-ADJACENT
4U	NON-ADJACENT
4V	NON-ADJACENT
4W	NON-ADJACENT
4X	NON-ADJACENT
4Y	NON-ADJACENT
4Z	NON-ADJACENT
5A	NON-ADJACENT
5B	NON-ADJACENT
5C	NON-ADJACENT
5D	NON-ADJACENT
5E	NON-ADJACENT
5F	NON-ADJACENT
5G	NON-ADJACENT
5H	NON-ADJACENT
5I	NON-ADJACENT
5J	NON-ADJACENT
5K	NON-ADJACENT
5L	NON-ADJACENT
5M	NON-ADJACENT
5N	NON-ADJACENT
5O	NON-ADJACENT
5P	NON-ADJACENT
5Q	NON-ADJACENT
5R	NON-ADJACENT
5S	NON-ADJACENT
5T	NON-ADJACENT
5U	NON-ADJACENT
5V	NON-ADJACENT
5W	NON-ADJACENT
5X	NON-ADJACENT
5Y	NON-ADJACENT
5Z	NON-ADJACENT
6A	NON-ADJACENT
6B	NON-ADJACENT
6C	NON-ADJACENT
6D	NON-ADJACENT
6E	NON-ADJACENT
6F	NON-ADJACENT
6G	NON-ADJACENT
6H	NON-ADJACENT
6I	NON-ADJACENT
6J	NON-ADJACENT
6K	NON-ADJACENT
6L	NON-ADJACENT
6M	NON-ADJACENT
6N	NON-ADJACENT
6O	NON-ADJACENT
6P	NON-ADJACENT
6Q	NON-ADJACENT
6R	NON-ADJACENT
6S	NON-ADJACENT
6T	NON-ADJACENT
6U	NON-ADJACENT
6V	NON-ADJACENT
6W	NON-ADJACENT
6X	NON-ADJACENT
6Y	NON-ADJACENT
6Z	NON-ADJACENT
7A	NON-ADJACENT
7B	NON-ADJACENT
7C	NON-ADJACENT
7D	NON-ADJACENT
7E	NON-ADJACENT
7F	NON-ADJACENT
7G	NON-ADJACENT
7H	NON-ADJACENT
7I	NON-ADJACENT
7J	NON-ADJACENT
7K	NON-ADJACENT
7L	NON-ADJACENT
7M	NON-ADJACENT
7N	NON-ADJACENT
7O	NON-ADJACENT
7P	NON-ADJACENT
7Q	NON-ADJACENT
7R	NON-ADJACENT
7S	NON-ADJACENT
7T	NON-ADJACENT
7U	NON-ADJACENT
7V	NON-ADJACENT
7W	NON-ADJACENT
7X	NON-ADJACENT
7Y	NON-ADJACENT
7Z	NON-ADJACENT
8A	NON-ADJACENT
8B	NON-ADJACENT
8C	NON-ADJACENT
8D	NON-ADJACENT
8E	NON-ADJACENT
8F	NON-ADJACENT
8G	NON-ADJACENT
8H	NON-ADJACENT
8I	NON-ADJACENT
8J	NON-ADJACENT
8K	NON-ADJACENT
8L	NON-ADJACENT
8M	NON-ADJACENT
8N	NON-ADJACENT
8O	NON-ADJACENT
8P	NON-ADJACENT
8Q	NON-ADJACENT
8R	NON-ADJACENT
8S	NON-ADJACENT
8T	NON-ADJACENT
8U	NON-ADJACENT
8V	NON-ADJACENT
8W	NON-ADJACENT
8X	NON-ADJACENT
8Y	NON-ADJACENT
8Z	NON-ADJACENT

MINNEAPOLIS / ST. PAUL  
 INTERNATIONAL AIRPORT  
 TERMINAL BUILDING  
 CONCOURSE A

FM124

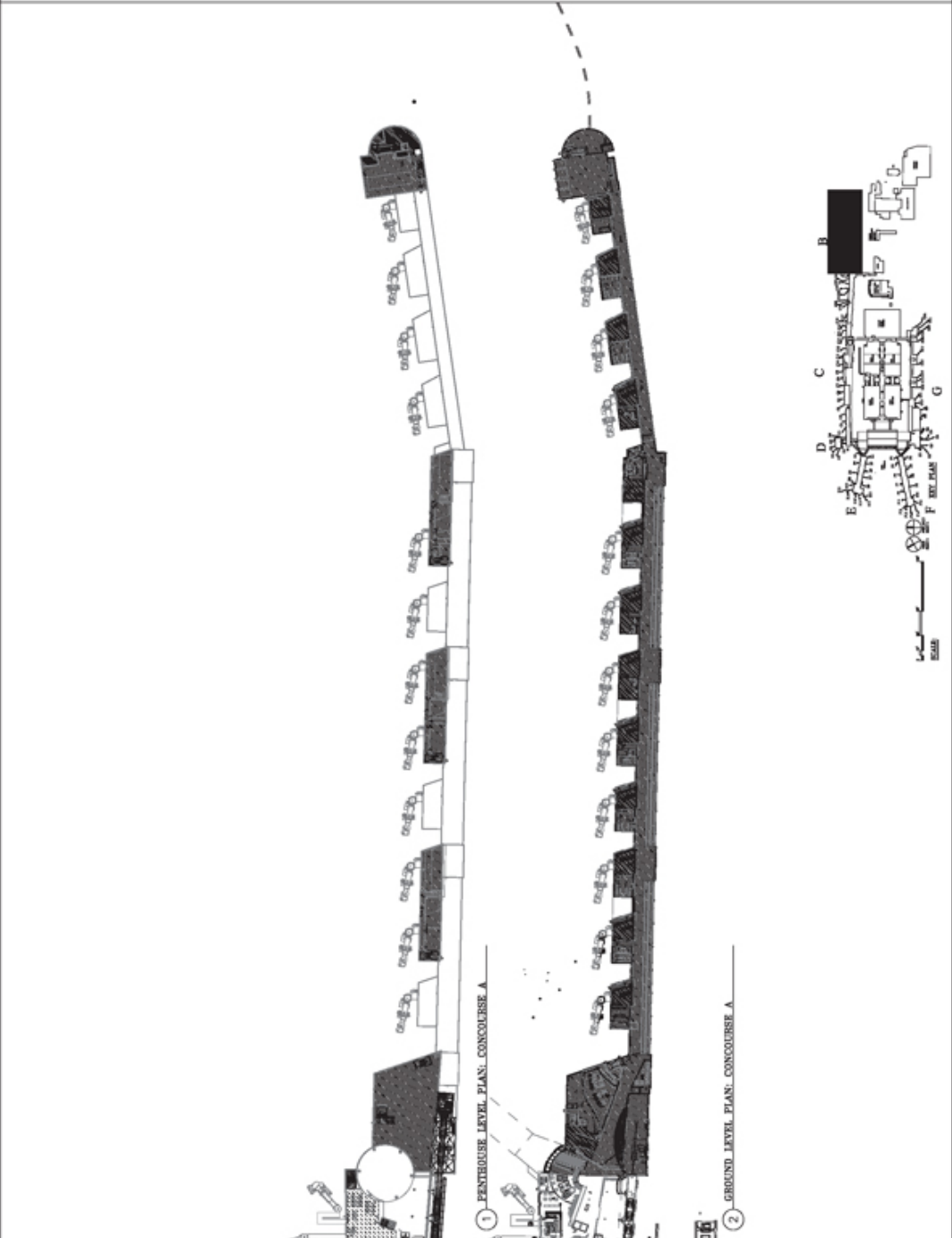

**EXHIBIT C**

Date : JANUARY 1, 2019  
 Page 20 of 28

LEGEND  
 TERMINAL BUILDING AREA



Metropolitan Airports Commission  
 6040 29th Avenue So.  
 Minneapolis, MN 55410



- Space Category Key**
- 1A PUBLIC CONCOURSE
  - 1B PUBLIC CONCOURSE
  - 1C PUBLIC CONCOURSE
  - 1D PUBLIC CONCOURSE
  - 1E PUBLIC CONCOURSE
  - 1F PUBLIC CONCOURSE
  - 1G PUBLIC CONCOURSE
  - 1H PUBLIC CONCOURSE
  - 1I PUBLIC CONCOURSE
  - 1J PUBLIC CONCOURSE
  - 1K PUBLIC CONCOURSE
  - 1L PUBLIC CONCOURSE
  - 1M PUBLIC CONCOURSE
  - 1N PUBLIC CONCOURSE
  - 1O PUBLIC CONCOURSE
  - 1P PUBLIC CONCOURSE
  - 1Q PUBLIC CONCOURSE
  - 1R PUBLIC CONCOURSE
  - 1S PUBLIC CONCOURSE
  - 1T PUBLIC CONCOURSE
  - 1U PUBLIC CONCOURSE
  - 1V PUBLIC CONCOURSE
  - 1W PUBLIC CONCOURSE
  - 1X PUBLIC CONCOURSE
  - 1Y PUBLIC CONCOURSE
  - 1Z PUBLIC CONCOURSE
  - 2A PUBLIC CONCOURSE
  - 2B PUBLIC CONCOURSE
  - 2C PUBLIC CONCOURSE
  - 2D PUBLIC CONCOURSE
  - 2E PUBLIC CONCOURSE
  - 2F PUBLIC CONCOURSE
  - 2G PUBLIC CONCOURSE
  - 2H PUBLIC CONCOURSE
  - 2I PUBLIC CONCOURSE
  - 2J PUBLIC CONCOURSE
  - 2K PUBLIC CONCOURSE
  - 2L PUBLIC CONCOURSE
  - 2M PUBLIC CONCOURSE
  - 2N PUBLIC CONCOURSE
  - 2O PUBLIC CONCOURSE
  - 2P PUBLIC CONCOURSE
  - 2Q PUBLIC CONCOURSE
  - 2R PUBLIC CONCOURSE
  - 2S PUBLIC CONCOURSE
  - 2T PUBLIC CONCOURSE
  - 2U PUBLIC CONCOURSE
  - 2V PUBLIC CONCOURSE
  - 2W PUBLIC CONCOURSE
  - 2X PUBLIC CONCOURSE
  - 2Y PUBLIC CONCOURSE
  - 2Z PUBLIC CONCOURSE
  - 3A PUBLIC CONCOURSE
  - 3B PUBLIC CONCOURSE
  - 3C PUBLIC CONCOURSE
  - 3D PUBLIC CONCOURSE
  - 3E PUBLIC CONCOURSE
  - 3F PUBLIC CONCOURSE
  - 3G PUBLIC CONCOURSE
  - 3H PUBLIC CONCOURSE
  - 3I PUBLIC CONCOURSE
  - 3J PUBLIC CONCOURSE
  - 3K PUBLIC CONCOURSE
  - 3L PUBLIC CONCOURSE
  - 3M PUBLIC CONCOURSE
  - 3N PUBLIC CONCOURSE
  - 3O PUBLIC CONCOURSE
  - 3P PUBLIC CONCOURSE
  - 3Q PUBLIC CONCOURSE
  - 3R PUBLIC CONCOURSE
  - 3S PUBLIC CONCOURSE
  - 3T PUBLIC CONCOURSE
  - 3U PUBLIC CONCOURSE
  - 3V PUBLIC CONCOURSE
  - 3W PUBLIC CONCOURSE
  - 3X PUBLIC CONCOURSE
  - 3Y PUBLIC CONCOURSE
  - 3Z PUBLIC CONCOURSE

MINNEAPOLIS / ST. PAUL INTERNATIONAL AIRPORT  
**TERMINAL BUILDING**  
 CONTOUR  
 CONTOUR B

FM125

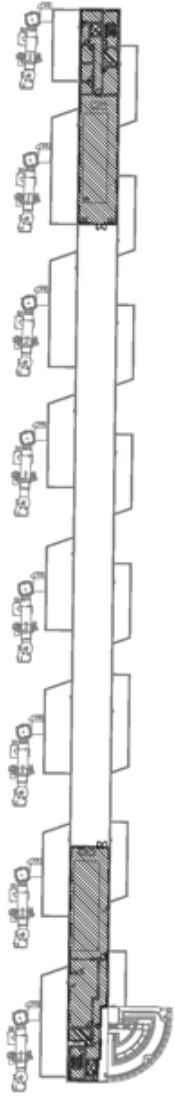

③ PENTHOUSE PLAN: CONCOURSE B

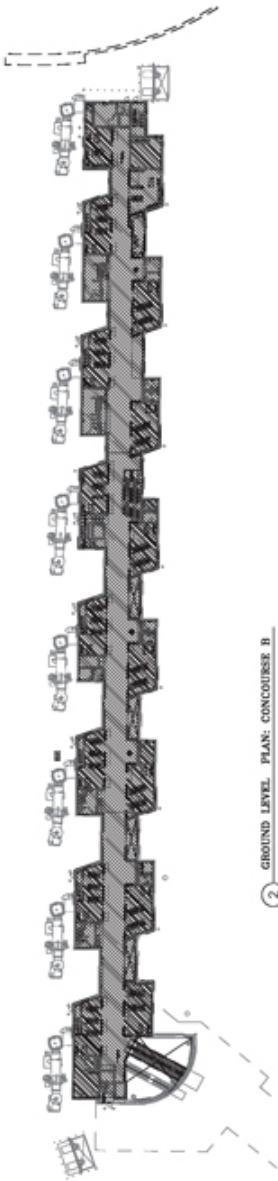

② GROUND LEVEL PLAN: CONCOURSE B

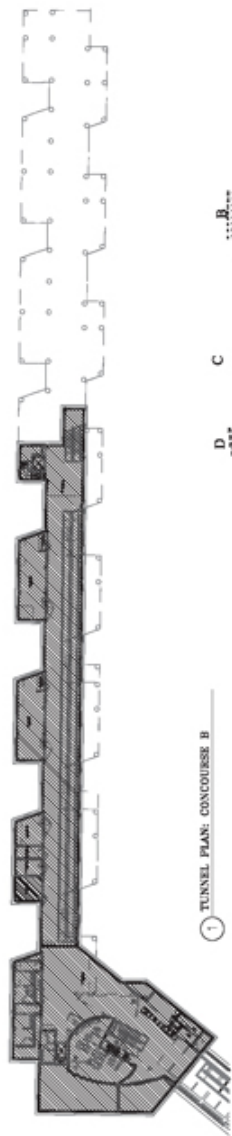

① TUNNEL PLAN: CONCOURSE B

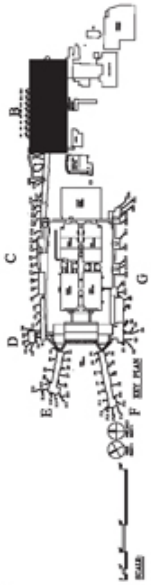

# EXHIBIT C

Date : JANUARY 1, 2019  
 Page 21 of 28

LEGEND  
 TERMINAL BUILDING AREA



Metropolitan Airports Commission  
 6040 29th Avenue So.  
 Minneapolis, MN 55416



**Space Category Key**

1A	PUBLIC CONCOURSE
1B	PUBLIC CONCOURSE
1C	PUBLIC CONCOURSE
1D	PUBLIC CONCOURSE
1E	PUBLIC CONCOURSE
1F	PUBLIC CONCOURSE
1G	PUBLIC CONCOURSE
1H	PUBLIC CONCOURSE
1I	PUBLIC CONCOURSE
1J	PUBLIC CONCOURSE
1K	PUBLIC CONCOURSE
1L	PUBLIC CONCOURSE
1M	PUBLIC CONCOURSE
1N	PUBLIC CONCOURSE
1O	PUBLIC CONCOURSE
1P	PUBLIC CONCOURSE
1Q	PUBLIC CONCOURSE
1R	PUBLIC CONCOURSE
1S	PUBLIC CONCOURSE
1T	PUBLIC CONCOURSE
1U	PUBLIC CONCOURSE
1V	PUBLIC CONCOURSE
1W	PUBLIC CONCOURSE
1X	PUBLIC CONCOURSE
1Y	PUBLIC CONCOURSE
1Z	PUBLIC CONCOURSE
2A	NON-AMINE FOOD & BEVERAGE
2B	NON-AMINE FOOD & BEVERAGE
2C	NON-AMINE FOOD & BEVERAGE
2D	NON-AMINE FOOD & BEVERAGE
2E	NON-AMINE FOOD & BEVERAGE
2F	NON-AMINE FOOD & BEVERAGE
2G	NON-AMINE FOOD & BEVERAGE
2H	NON-AMINE FOOD & BEVERAGE
2I	NON-AMINE FOOD & BEVERAGE
2J	NON-AMINE FOOD & BEVERAGE
2K	NON-AMINE FOOD & BEVERAGE
2L	NON-AMINE FOOD & BEVERAGE
2M	NON-AMINE FOOD & BEVERAGE
2N	NON-AMINE FOOD & BEVERAGE
2O	NON-AMINE FOOD & BEVERAGE
2P	NON-AMINE FOOD & BEVERAGE
2Q	NON-AMINE FOOD & BEVERAGE
2R	NON-AMINE FOOD & BEVERAGE
2S	NON-AMINE FOOD & BEVERAGE
2T	NON-AMINE FOOD & BEVERAGE
2U	NON-AMINE FOOD & BEVERAGE
2V	NON-AMINE FOOD & BEVERAGE
2W	NON-AMINE FOOD & BEVERAGE
2X	NON-AMINE FOOD & BEVERAGE
2Y	NON-AMINE FOOD & BEVERAGE
2Z	NON-AMINE FOOD & BEVERAGE
3A	MECHANICAL
3B	MECHANICAL
3C	MECHANICAL
3D	MECHANICAL
3E	MECHANICAL
3F	MECHANICAL
3G	MECHANICAL
3H	MECHANICAL
3I	MECHANICAL
3J	MECHANICAL
3K	MECHANICAL
3L	MECHANICAL
3M	MECHANICAL
3N	MECHANICAL
3O	MECHANICAL
3P	MECHANICAL
3Q	MECHANICAL
3R	MECHANICAL
3S	MECHANICAL
3T	MECHANICAL
3U	MECHANICAL
3V	MECHANICAL
3W	MECHANICAL
3X	MECHANICAL
3Y	MECHANICAL
3Z	MECHANICAL
4A	MECHANICAL
4B	MECHANICAL
4C	MECHANICAL
4D	MECHANICAL
4E	MECHANICAL
4F	MECHANICAL
4G	MECHANICAL
4H	MECHANICAL
4I	MECHANICAL
4J	MECHANICAL
4K	MECHANICAL
4L	MECHANICAL
4M	MECHANICAL
4N	MECHANICAL
4O	MECHANICAL
4P	MECHANICAL
4Q	MECHANICAL
4R	MECHANICAL
4S	MECHANICAL
4T	MECHANICAL
4U	MECHANICAL
4V	MECHANICAL
4W	MECHANICAL
4X	MECHANICAL
4Y	MECHANICAL
4Z	MECHANICAL

MINNEAPOLIS / ST. PAUL INTERNATIONAL AIRPORT  
**TERMINAL BUILDING**  
 HUB AREA  
 BASEMENT PLAN

FM126

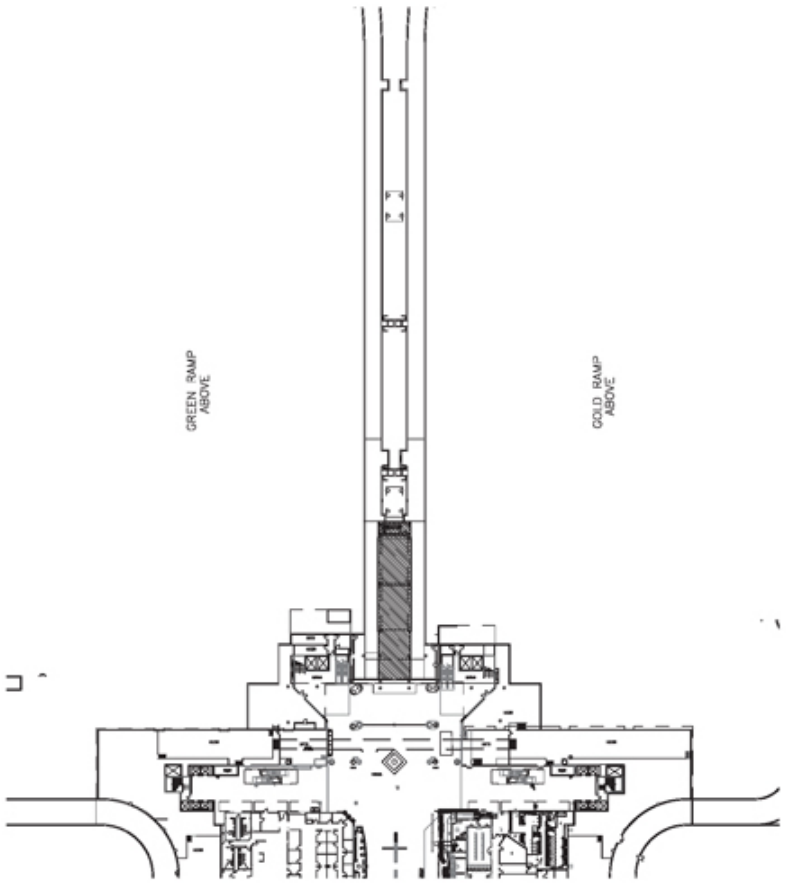

1 BASEMENT LEVEL PLAN: GREEN/GOLD PARKING & HUB TRAM

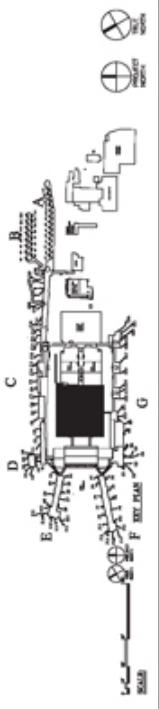



# EXHIBIT C

Date : JANUARY 1, 2019  
 Page 22 of 28

LEGEND  
 TERMINAL BUILDING AREA



Metropolitan  
 Airports  
 Commission  
 6040 29th Avenue So.  
 Minneapolis, MN 55410



Space Category Key

1A	PUBLIC CONCOURSE
1B	PUBLIC CONCOURSE
1C	PUBLIC CONCOURSE
1D	PUBLIC CONCOURSE
1E	PUBLIC CONCOURSE
1F	PUBLIC CONCOURSE
1G	PUBLIC CONCOURSE
1H	PUBLIC CONCOURSE
1I	PUBLIC CONCOURSE
1J	PUBLIC CONCOURSE
1K	PUBLIC CONCOURSE
1L	PUBLIC CONCOURSE
1M	PUBLIC CONCOURSE
1N	PUBLIC CONCOURSE
1O	PUBLIC CONCOURSE
1P	PUBLIC CONCOURSE
1Q	PUBLIC CONCOURSE
1R	PUBLIC CONCOURSE
1S	PUBLIC CONCOURSE
1T	PUBLIC CONCOURSE
1U	PUBLIC CONCOURSE
1V	PUBLIC CONCOURSE
1W	PUBLIC CONCOURSE
1X	PUBLIC CONCOURSE
1Y	PUBLIC CONCOURSE
1Z	PUBLIC CONCOURSE
2A	NON-ARRIVAL CONCOURSE
2B	NON-ARRIVAL CONCOURSE
2C	NON-ARRIVAL CONCOURSE
2D	NON-ARRIVAL CONCOURSE
2E	NON-ARRIVAL CONCOURSE
2F	NON-ARRIVAL CONCOURSE
2G	NON-ARRIVAL CONCOURSE
2H	NON-ARRIVAL CONCOURSE
2I	NON-ARRIVAL CONCOURSE
2J	NON-ARRIVAL CONCOURSE
2K	NON-ARRIVAL CONCOURSE
2L	NON-ARRIVAL CONCOURSE
2M	NON-ARRIVAL CONCOURSE
2N	NON-ARRIVAL CONCOURSE
2O	NON-ARRIVAL CONCOURSE
2P	NON-ARRIVAL CONCOURSE
2Q	NON-ARRIVAL CONCOURSE
2R	NON-ARRIVAL CONCOURSE
2S	NON-ARRIVAL CONCOURSE
2T	NON-ARRIVAL CONCOURSE
2U	NON-ARRIVAL CONCOURSE
2V	NON-ARRIVAL CONCOURSE
2W	NON-ARRIVAL CONCOURSE
2X	NON-ARRIVAL CONCOURSE
2Y	NON-ARRIVAL CONCOURSE
2Z	NON-ARRIVAL CONCOURSE
3A	NON-ARRIVAL CONCOURSE
3B	NON-ARRIVAL CONCOURSE
3C	NON-ARRIVAL CONCOURSE
3D	NON-ARRIVAL CONCOURSE
3E	NON-ARRIVAL CONCOURSE
3F	NON-ARRIVAL CONCOURSE
3G	NON-ARRIVAL CONCOURSE
3H	NON-ARRIVAL CONCOURSE
3I	NON-ARRIVAL CONCOURSE
3J	NON-ARRIVAL CONCOURSE
3K	NON-ARRIVAL CONCOURSE
3L	NON-ARRIVAL CONCOURSE
3M	NON-ARRIVAL CONCOURSE
3N	NON-ARRIVAL CONCOURSE
3O	NON-ARRIVAL CONCOURSE
3P	NON-ARRIVAL CONCOURSE
3Q	NON-ARRIVAL CONCOURSE
3R	NON-ARRIVAL CONCOURSE
3S	NON-ARRIVAL CONCOURSE
3T	NON-ARRIVAL CONCOURSE
3U	NON-ARRIVAL CONCOURSE
3V	NON-ARRIVAL CONCOURSE
3W	NON-ARRIVAL CONCOURSE
3X	NON-ARRIVAL CONCOURSE
3Y	NON-ARRIVAL CONCOURSE
3Z	NON-ARRIVAL CONCOURSE
4A	NON-ARRIVAL CONCOURSE
4B	NON-ARRIVAL CONCOURSE
4C	NON-ARRIVAL CONCOURSE
4D	NON-ARRIVAL CONCOURSE
4E	NON-ARRIVAL CONCOURSE
4F	NON-ARRIVAL CONCOURSE
4G	NON-ARRIVAL CONCOURSE
4H	NON-ARRIVAL CONCOURSE
4I	NON-ARRIVAL CONCOURSE
4J	NON-ARRIVAL CONCOURSE
4K	NON-ARRIVAL CONCOURSE
4L	NON-ARRIVAL CONCOURSE
4M	NON-ARRIVAL CONCOURSE
4N	NON-ARRIVAL CONCOURSE
4O	NON-ARRIVAL CONCOURSE
4P	NON-ARRIVAL CONCOURSE
4Q	NON-ARRIVAL CONCOURSE
4R	NON-ARRIVAL CONCOURSE
4S	NON-ARRIVAL CONCOURSE
4T	NON-ARRIVAL CONCOURSE
4U	NON-ARRIVAL CONCOURSE
4V	NON-ARRIVAL CONCOURSE
4W	NON-ARRIVAL CONCOURSE
4X	NON-ARRIVAL CONCOURSE
4Y	NON-ARRIVAL CONCOURSE
4Z	NON-ARRIVAL CONCOURSE
5A	NON-ARRIVAL CONCOURSE
5B	NON-ARRIVAL CONCOURSE
5C	NON-ARRIVAL CONCOURSE
5D	NON-ARRIVAL CONCOURSE
5E	NON-ARRIVAL CONCOURSE
5F	NON-ARRIVAL CONCOURSE
5G	NON-ARRIVAL CONCOURSE
5H	NON-ARRIVAL CONCOURSE
5I	NON-ARRIVAL CONCOURSE
5J	NON-ARRIVAL CONCOURSE
5K	NON-ARRIVAL CONCOURSE
5L	NON-ARRIVAL CONCOURSE
5M	NON-ARRIVAL CONCOURSE
5N	NON-ARRIVAL CONCOURSE
5O	NON-ARRIVAL CONCOURSE
5P	NON-ARRIVAL CONCOURSE
5Q	NON-ARRIVAL CONCOURSE
5R	NON-ARRIVAL CONCOURSE
5S	NON-ARRIVAL CONCOURSE
5T	NON-ARRIVAL CONCOURSE
5U	NON-ARRIVAL CONCOURSE
5V	NON-ARRIVAL CONCOURSE
5W	NON-ARRIVAL CONCOURSE
5X	NON-ARRIVAL CONCOURSE
5Y	NON-ARRIVAL CONCOURSE
5Z	NON-ARRIVAL CONCOURSE
6A	NON-ARRIVAL CONCOURSE
6B	NON-ARRIVAL CONCOURSE
6C	NON-ARRIVAL CONCOURSE
6D	NON-ARRIVAL CONCOURSE
6E	NON-ARRIVAL CONCOURSE
6F	NON-ARRIVAL CONCOURSE
6G	NON-ARRIVAL CONCOURSE
6H	NON-ARRIVAL CONCOURSE
6I	NON-ARRIVAL CONCOURSE
6J	NON-ARRIVAL CONCOURSE
6K	NON-ARRIVAL CONCOURSE
6L	NON-ARRIVAL CONCOURSE
6M	NON-ARRIVAL CONCOURSE
6N	NON-ARRIVAL CONCOURSE
6O	NON-ARRIVAL CONCOURSE
6P	NON-ARRIVAL CONCOURSE
6Q	NON-ARRIVAL CONCOURSE
6R	NON-ARRIVAL CONCOURSE
6S	NON-ARRIVAL CONCOURSE
6T	NON-ARRIVAL CONCOURSE
6U	NON-ARRIVAL CONCOURSE
6V	NON-ARRIVAL CONCOURSE
6W	NON-ARRIVAL CONCOURSE
6X	NON-ARRIVAL CONCOURSE
6Y	NON-ARRIVAL CONCOURSE
6Z	NON-ARRIVAL CONCOURSE
7A	NON-ARRIVAL CONCOURSE
7B	NON-ARRIVAL CONCOURSE
7C	NON-ARRIVAL CONCOURSE
7D	NON-ARRIVAL CONCOURSE
7E	NON-ARRIVAL CONCOURSE
7F	NON-ARRIVAL CONCOURSE
7G	NON-ARRIVAL CONCOURSE
7H	NON-ARRIVAL CONCOURSE
7I	NON-ARRIVAL CONCOURSE
7J	NON-ARRIVAL CONCOURSE
7K	NON-ARRIVAL CONCOURSE
7L	NON-ARRIVAL CONCOURSE
7M	NON-ARRIVAL CONCOURSE
7N	NON-ARRIVAL CONCOURSE
7O	NON-ARRIVAL CONCOURSE
7P	NON-ARRIVAL CONCOURSE
7Q	NON-ARRIVAL CONCOURSE
7R	NON-ARRIVAL CONCOURSE
7S	NON-ARRIVAL CONCOURSE
7T	NON-ARRIVAL CONCOURSE
7U	NON-ARRIVAL CONCOURSE
7V	NON-ARRIVAL CONCOURSE
7W	NON-ARRIVAL CONCOURSE
7X	NON-ARRIVAL CONCOURSE
7Y	NON-ARRIVAL CONCOURSE
7Z	NON-ARRIVAL CONCOURSE
8A	NON-ARRIVAL CONCOURSE
8B	NON-ARRIVAL CONCOURSE
8C	NON-ARRIVAL CONCOURSE
8D	NON-ARRIVAL CONCOURSE
8E	NON-ARRIVAL CONCOURSE
8F	NON-ARRIVAL CONCOURSE
8G	NON-ARRIVAL CONCOURSE
8H	NON-ARRIVAL CONCOURSE
8I	NON-ARRIVAL CONCOURSE
8J	NON-ARRIVAL CONCOURSE
8K	NON-ARRIVAL CONCOURSE
8L	NON-ARRIVAL CONCOURSE
8M	NON-ARRIVAL CONCOURSE
8N	NON-ARRIVAL CONCOURSE
8O	NON-ARRIVAL CONCOURSE
8P	NON-ARRIVAL CONCOURSE
8Q	NON-ARRIVAL CONCOURSE
8R	NON-ARRIVAL CONCOURSE
8S	NON-ARRIVAL CONCOURSE
8T	NON-ARRIVAL CONCOURSE
8U	NON-ARRIVAL CONCOURSE
8V	NON-ARRIVAL CONCOURSE
8W	NON-ARRIVAL CONCOURSE
8X	NON-ARRIVAL CONCOURSE
8Y	NON-ARRIVAL CONCOURSE
8Z	NON-ARRIVAL CONCOURSE

MINNEAPOLIS / ST. PAUL  
 INTERNATIONAL AIRPORT  
 TERMINAL BUILDING  
 HUB AREA  
 BASEMENT

FM135

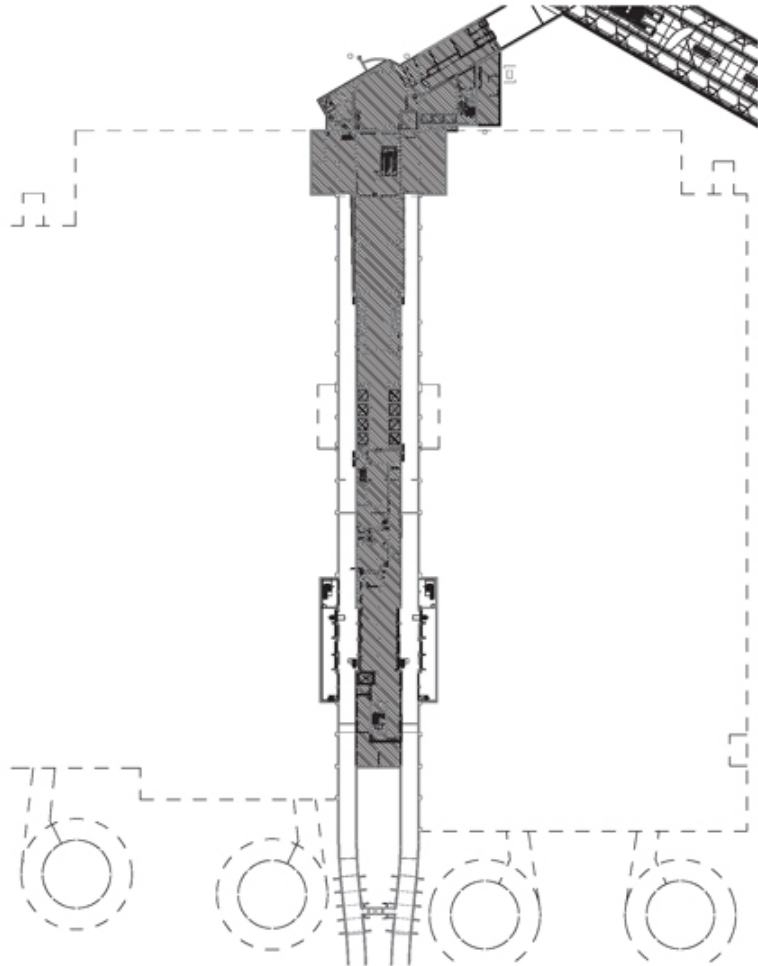

① BASEMENT LEVEL PLAN: BLUE/RED PARKING & HUB TRAIN

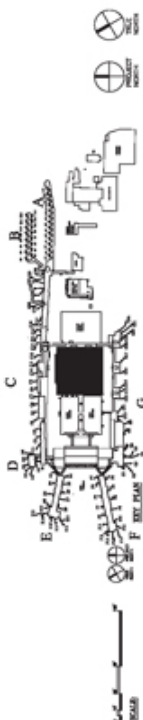

# EXHIBIT C

Date : JANUARY 1, 2019  
 Page 23 of 28

LEGEND  
 TERMINAL BUILDING  
 AREA



Metropolitan  
 Airports  
 Commission  
 6040 29th Avenue So.  
 Minneapolis, MN 55416

WITH A SQUARE FOOT

SPACE NAME	SPACE CATEGORY
1A	PUBLIC CONCOURSE
1B	PUBLIC CONCOURSE
1C	PUBLIC CONCOURSE
1D	PUBLIC CONCOURSE
1E	PUBLIC CONCOURSE
1F	PUBLIC CONCOURSE
1G	PUBLIC CONCOURSE
1H	PUBLIC CONCOURSE
1I	PUBLIC CONCOURSE
1J	PUBLIC CONCOURSE
1K	PUBLIC CONCOURSE
1L	PUBLIC CONCOURSE
1M	PUBLIC CONCOURSE
1N	PUBLIC CONCOURSE
1O	PUBLIC CONCOURSE
1P	PUBLIC CONCOURSE
1Q	PUBLIC CONCOURSE
1R	PUBLIC CONCOURSE
1S	PUBLIC CONCOURSE
1T	PUBLIC CONCOURSE
1U	PUBLIC CONCOURSE
1V	PUBLIC CONCOURSE
1W	PUBLIC CONCOURSE
1X	PUBLIC CONCOURSE
1Y	PUBLIC CONCOURSE
1Z	PUBLIC CONCOURSE
2A	ARRIVAL CONCOURSE
2B	ARRIVAL CONCOURSE
2C	ARRIVAL CONCOURSE
2D	ARRIVAL CONCOURSE
2E	ARRIVAL CONCOURSE
2F	ARRIVAL CONCOURSE
2G	ARRIVAL CONCOURSE
2H	ARRIVAL CONCOURSE
2I	ARRIVAL CONCOURSE
2J	ARRIVAL CONCOURSE
2K	ARRIVAL CONCOURSE
2L	ARRIVAL CONCOURSE
2M	ARRIVAL CONCOURSE
2N	ARRIVAL CONCOURSE
2O	ARRIVAL CONCOURSE
2P	ARRIVAL CONCOURSE
2Q	ARRIVAL CONCOURSE
2R	ARRIVAL CONCOURSE
2S	ARRIVAL CONCOURSE
2T	ARRIVAL CONCOURSE
2U	ARRIVAL CONCOURSE
2V	ARRIVAL CONCOURSE
2W	ARRIVAL CONCOURSE
2X	ARRIVAL CONCOURSE
2Y	ARRIVAL CONCOURSE
2Z	ARRIVAL CONCOURSE
3A	ARRIVAL CONCOURSE
3B	ARRIVAL CONCOURSE
3C	ARRIVAL CONCOURSE
3D	ARRIVAL CONCOURSE
3E	ARRIVAL CONCOURSE
3F	ARRIVAL CONCOURSE
3G	ARRIVAL CONCOURSE
3H	ARRIVAL CONCOURSE
3I	ARRIVAL CONCOURSE
3J	ARRIVAL CONCOURSE
3K	ARRIVAL CONCOURSE
3L	ARRIVAL CONCOURSE
3M	ARRIVAL CONCOURSE
3N	ARRIVAL CONCOURSE
3O	ARRIVAL CONCOURSE
3P	ARRIVAL CONCOURSE
3Q	ARRIVAL CONCOURSE
3R	ARRIVAL CONCOURSE
3S	ARRIVAL CONCOURSE
3T	ARRIVAL CONCOURSE
3U	ARRIVAL CONCOURSE
3V	ARRIVAL CONCOURSE
3W	ARRIVAL CONCOURSE
3X	ARRIVAL CONCOURSE
3Y	ARRIVAL CONCOURSE
3Z	ARRIVAL CONCOURSE
4A	ARRIVAL CONCOURSE
4B	ARRIVAL CONCOURSE
4C	ARRIVAL CONCOURSE
4D	ARRIVAL CONCOURSE
4E	ARRIVAL CONCOURSE
4F	ARRIVAL CONCOURSE
4G	ARRIVAL CONCOURSE
4H	ARRIVAL CONCOURSE
4I	ARRIVAL CONCOURSE
4J	ARRIVAL CONCOURSE
4K	ARRIVAL CONCOURSE
4L	ARRIVAL CONCOURSE
4M	ARRIVAL CONCOURSE
4N	ARRIVAL CONCOURSE
4O	ARRIVAL CONCOURSE
4P	ARRIVAL CONCOURSE
4Q	ARRIVAL CONCOURSE
4R	ARRIVAL CONCOURSE
4S	ARRIVAL CONCOURSE
4T	ARRIVAL CONCOURSE
4U	ARRIVAL CONCOURSE
4V	ARRIVAL CONCOURSE
4W	ARRIVAL CONCOURSE
4X	ARRIVAL CONCOURSE
4Y	ARRIVAL CONCOURSE
4Z	ARRIVAL CONCOURSE
5A	ARRIVAL CONCOURSE
5B	ARRIVAL CONCOURSE
5C	ARRIVAL CONCOURSE
5D	ARRIVAL CONCOURSE
5E	ARRIVAL CONCOURSE
5F	ARRIVAL CONCOURSE
5G	ARRIVAL CONCOURSE
5H	ARRIVAL CONCOURSE
5I	ARRIVAL CONCOURSE
5J	ARRIVAL CONCOURSE
5K	ARRIVAL CONCOURSE
5L	ARRIVAL CONCOURSE
5M	ARRIVAL CONCOURSE
5N	ARRIVAL CONCOURSE
5O	ARRIVAL CONCOURSE
5P	ARRIVAL CONCOURSE
5Q	ARRIVAL CONCOURSE
5R	ARRIVAL CONCOURSE
5S	ARRIVAL CONCOURSE
5T	ARRIVAL CONCOURSE
5U	ARRIVAL CONCOURSE
5V	ARRIVAL CONCOURSE
5W	ARRIVAL CONCOURSE
5X	ARRIVAL CONCOURSE
5Y	ARRIVAL CONCOURSE
5Z	ARRIVAL CONCOURSE
6A	ARRIVAL CONCOURSE
6B	ARRIVAL CONCOURSE
6C	ARRIVAL CONCOURSE
6D	ARRIVAL CONCOURSE
6E	ARRIVAL CONCOURSE
6F	ARRIVAL CONCOURSE
6G	ARRIVAL CONCOURSE
6H	ARRIVAL CONCOURSE
6I	ARRIVAL CONCOURSE
6J	ARRIVAL CONCOURSE
6K	ARRIVAL CONCOURSE
6L	ARRIVAL CONCOURSE
6M	ARRIVAL CONCOURSE
6N	ARRIVAL CONCOURSE
6O	ARRIVAL CONCOURSE
6P	ARRIVAL CONCOURSE
6Q	ARRIVAL CONCOURSE
6R	ARRIVAL CONCOURSE
6S	ARRIVAL CONCOURSE
6T	ARRIVAL CONCOURSE
6U	ARRIVAL CONCOURSE
6V	ARRIVAL CONCOURSE
6W	ARRIVAL CONCOURSE
6X	ARRIVAL CONCOURSE
6Y	ARRIVAL CONCOURSE
6Z	ARRIVAL CONCOURSE
7A	ARRIVAL CONCOURSE
7B	ARRIVAL CONCOURSE
7C	ARRIVAL CONCOURSE
7D	ARRIVAL CONCOURSE
7E	ARRIVAL CONCOURSE
7F	ARRIVAL CONCOURSE
7G	ARRIVAL CONCOURSE
7H	ARRIVAL CONCOURSE
7I	ARRIVAL CONCOURSE
7J	ARRIVAL CONCOURSE
7K	ARRIVAL CONCOURSE
7L	ARRIVAL CONCOURSE
7M	ARRIVAL CONCOURSE
7N	ARRIVAL CONCOURSE
7O	ARRIVAL CONCOURSE
7P	ARRIVAL CONCOURSE
7Q	ARRIVAL CONCOURSE
7R	ARRIVAL CONCOURSE
7S	ARRIVAL CONCOURSE
7T	ARRIVAL CONCOURSE
7U	ARRIVAL CONCOURSE
7V	ARRIVAL CONCOURSE
7W	ARRIVAL CONCOURSE
7X	ARRIVAL CONCOURSE
7Y	ARRIVAL CONCOURSE
7Z	ARRIVAL CONCOURSE
8A	ARRIVAL CONCOURSE
8B	ARRIVAL CONCOURSE
8C	ARRIVAL CONCOURSE
8D	ARRIVAL CONCOURSE
8E	ARRIVAL CONCOURSE
8F	ARRIVAL CONCOURSE
8G	ARRIVAL CONCOURSE
8H	ARRIVAL CONCOURSE
8I	ARRIVAL CONCOURSE
8J	ARRIVAL CONCOURSE
8K	ARRIVAL CONCOURSE
8L	ARRIVAL CONCOURSE
8M	ARRIVAL CONCOURSE
8N	ARRIVAL CONCOURSE
8O	ARRIVAL CONCOURSE
8P	ARRIVAL CONCOURSE
8Q	ARRIVAL CONCOURSE
8R	ARRIVAL CONCOURSE
8S	ARRIVAL CONCOURSE
8T	ARRIVAL CONCOURSE
8U	ARRIVAL CONCOURSE
8V	ARRIVAL CONCOURSE
8W	ARRIVAL CONCOURSE
8X	ARRIVAL CONCOURSE
8Y	ARRIVAL CONCOURSE
8Z	ARRIVAL CONCOURSE
9A	ARRIVAL CONCOURSE
9B	ARRIVAL CONCOURSE
9C	ARRIVAL CONCOURSE
9D	ARRIVAL CONCOURSE
9E	ARRIVAL CONCOURSE
9F	ARRIVAL CONCOURSE
9G	ARRIVAL CONCOURSE
9H	ARRIVAL CONCOURSE
9I	ARRIVAL CONCOURSE
9J	ARRIVAL CONCOURSE
9K	ARRIVAL CONCOURSE
9L	ARRIVAL CONCOURSE
9M	ARRIVAL CONCOURSE
9N	ARRIVAL CONCOURSE
9O	ARRIVAL CONCOURSE
9P	ARRIVAL CONCOURSE
9Q	ARRIVAL CONCOURSE
9R	ARRIVAL CONCOURSE
9S	ARRIVAL CONCOURSE
9T	ARRIVAL CONCOURSE
9U	ARRIVAL CONCOURSE
9V	ARRIVAL CONCOURSE
9W	ARRIVAL CONCOURSE
9X	ARRIVAL CONCOURSE
9Y	ARRIVAL CONCOURSE
9Z	ARRIVAL CONCOURSE

MINNEAPOLIS / ST. PAUL  
 INTERNATIONAL AIRPORT  
 TERMINAL BUILDING  
 HUB AREA  
 GROUND LEVEL

FM137

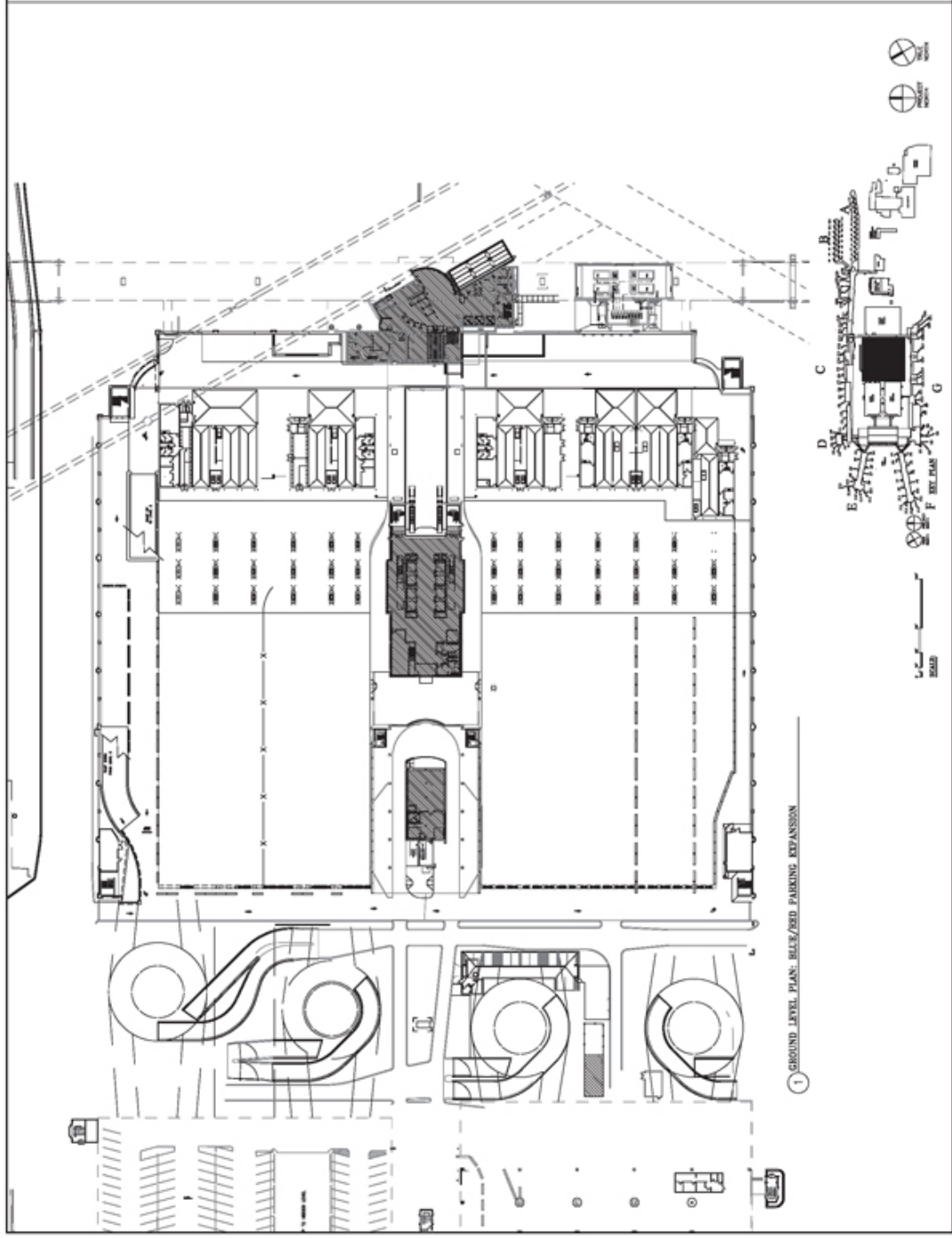

① GROUND LEVEL PLAN: BLUE/RED PARKING EXPANSION



# EXHIBIT C

Date : JANUARY 1, 2019  
 Page 24 of 28

LEGEND  
 TERMINAL BUILDING AREA



Metropolitan Airports Commission  
 6040 29th Avenue So.  
 Minneapolis, MN 55416

Space Category Key

1	TRAVEL
2	SPACE OUTDOOR
3	NON-ADJACENT
4	NON-ADJACENT OR ADJACENT
5	NON-ADJACENT
6	NON-ADJACENT
7	NON-ADJACENT
8	NON-ADJACENT
9	NON-ADJACENT
10	NON-ADJACENT
11	NON-ADJACENT
12	NON-ADJACENT
13	NON-ADJACENT
14	NON-ADJACENT
15	NON-ADJACENT
16	NON-ADJACENT
17	NON-ADJACENT
18	NON-ADJACENT
19	NON-ADJACENT
20	NON-ADJACENT
21	NON-ADJACENT
22	NON-ADJACENT
23	NON-ADJACENT
24	NON-ADJACENT
25	NON-ADJACENT
26	NON-ADJACENT
27	NON-ADJACENT
28	NON-ADJACENT
29	NON-ADJACENT
30	NON-ADJACENT
31	NON-ADJACENT
32	NON-ADJACENT
33	NON-ADJACENT
34	NON-ADJACENT
35	NON-ADJACENT
36	NON-ADJACENT
37	NON-ADJACENT
38	NON-ADJACENT
39	NON-ADJACENT
40	NON-ADJACENT
41	NON-ADJACENT
42	NON-ADJACENT
43	NON-ADJACENT
44	NON-ADJACENT
45	NON-ADJACENT
46	NON-ADJACENT
47	NON-ADJACENT
48	NON-ADJACENT
49	NON-ADJACENT
50	NON-ADJACENT
51	NON-ADJACENT
52	NON-ADJACENT
53	NON-ADJACENT
54	NON-ADJACENT
55	NON-ADJACENT
56	NON-ADJACENT
57	NON-ADJACENT
58	NON-ADJACENT
59	NON-ADJACENT
60	NON-ADJACENT
61	NON-ADJACENT
62	NON-ADJACENT
63	NON-ADJACENT
64	NON-ADJACENT
65	NON-ADJACENT
66	NON-ADJACENT
67	NON-ADJACENT
68	NON-ADJACENT
69	NON-ADJACENT
70	NON-ADJACENT
71	NON-ADJACENT
72	NON-ADJACENT
73	NON-ADJACENT
74	NON-ADJACENT
75	NON-ADJACENT
76	NON-ADJACENT
77	NON-ADJACENT
78	NON-ADJACENT
79	NON-ADJACENT
80	NON-ADJACENT
81	NON-ADJACENT
82	NON-ADJACENT
83	NON-ADJACENT
84	NON-ADJACENT
85	NON-ADJACENT
86	NON-ADJACENT
87	NON-ADJACENT
88	NON-ADJACENT
89	NON-ADJACENT
90	NON-ADJACENT
91	NON-ADJACENT
92	NON-ADJACENT
93	NON-ADJACENT
94	NON-ADJACENT
95	NON-ADJACENT
96	NON-ADJACENT
97	NON-ADJACENT
98	NON-ADJACENT
99	NON-ADJACENT
100	NON-ADJACENT

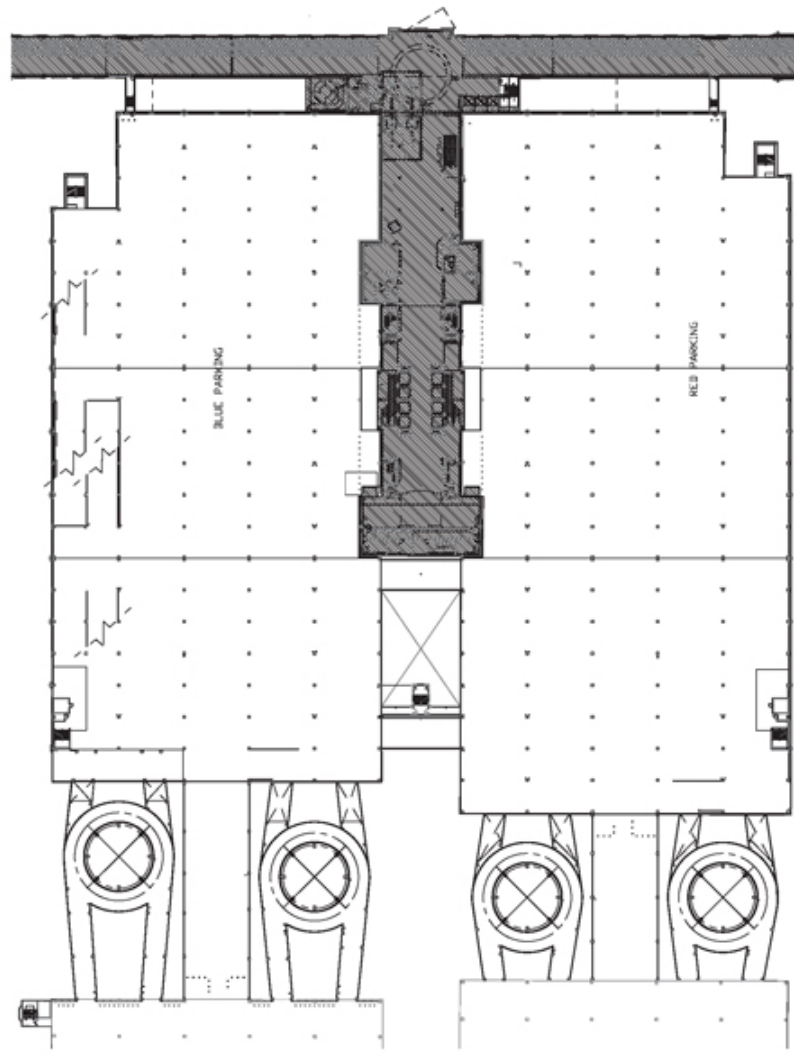

① SECOND FLOOR PLAN: BLUE/RED PARKING EXPANSION

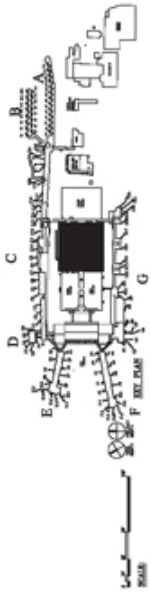

MINNEAPOLIS/ST. PAUL INTERNATIONAL AIRPORT  
 TERMINAL BUILDING  
 RED AND BLUE RAMP

# EXHIBIT C

Date : JANUARY 1, 2019  
 Page 25 of 28

LEGEND  
 TERMINAL BUILDING AREA



Metropolitan Airports Commission  
 6040 29th Avenue So.  
 Minneapolis, MN 55410

Space Category Key

1A	PUBLIC CONCOURSE
1B	TRAVEL CONCOURSE
1C	TRAVEL CONCOURSE
1D	TRAVEL CONCOURSE
1E	TRAVEL CONCOURSE
1F	TRAVEL CONCOURSE
1G	TRAVEL CONCOURSE
1H	TRAVEL CONCOURSE
1I	TRAVEL CONCOURSE
1J	TRAVEL CONCOURSE
1K	TRAVEL CONCOURSE
1L	TRAVEL CONCOURSE
1M	TRAVEL CONCOURSE
1N	TRAVEL CONCOURSE
1O	TRAVEL CONCOURSE
1P	TRAVEL CONCOURSE
1Q	TRAVEL CONCOURSE
1R	TRAVEL CONCOURSE
1S	TRAVEL CONCOURSE
1T	TRAVEL CONCOURSE
1U	TRAVEL CONCOURSE
1V	TRAVEL CONCOURSE
1W	TRAVEL CONCOURSE
1X	TRAVEL CONCOURSE
1Y	TRAVEL CONCOURSE
1Z	TRAVEL CONCOURSE
2A	TRAVEL CONCOURSE
2B	TRAVEL CONCOURSE
2C	TRAVEL CONCOURSE
2D	TRAVEL CONCOURSE
2E	TRAVEL CONCOURSE
2F	TRAVEL CONCOURSE
2G	TRAVEL CONCOURSE
2H	TRAVEL CONCOURSE
2I	TRAVEL CONCOURSE
2J	TRAVEL CONCOURSE
2K	TRAVEL CONCOURSE
2L	TRAVEL CONCOURSE
2M	TRAVEL CONCOURSE
2N	TRAVEL CONCOURSE
2O	TRAVEL CONCOURSE
2P	TRAVEL CONCOURSE
2Q	TRAVEL CONCOURSE
2R	TRAVEL CONCOURSE
2S	TRAVEL CONCOURSE
2T	TRAVEL CONCOURSE
2U	TRAVEL CONCOURSE
2V	TRAVEL CONCOURSE
2W	TRAVEL CONCOURSE
2X	TRAVEL CONCOURSE
2Y	TRAVEL CONCOURSE
2Z	TRAVEL CONCOURSE
3A	TRAVEL CONCOURSE
3B	TRAVEL CONCOURSE
3C	TRAVEL CONCOURSE
3D	TRAVEL CONCOURSE
3E	TRAVEL CONCOURSE
3F	TRAVEL CONCOURSE
3G	TRAVEL CONCOURSE
3H	TRAVEL CONCOURSE
3I	TRAVEL CONCOURSE
3J	TRAVEL CONCOURSE
3K	TRAVEL CONCOURSE
3L	TRAVEL CONCOURSE
3M	TRAVEL CONCOURSE
3N	TRAVEL CONCOURSE
3O	TRAVEL CONCOURSE
3P	TRAVEL CONCOURSE
3Q	TRAVEL CONCOURSE
3R	TRAVEL CONCOURSE
3S	TRAVEL CONCOURSE
3T	TRAVEL CONCOURSE
3U	TRAVEL CONCOURSE
3V	TRAVEL CONCOURSE
3W	TRAVEL CONCOURSE
3X	TRAVEL CONCOURSE
3Y	TRAVEL CONCOURSE
3Z	TRAVEL CONCOURSE
4A	TRAVEL CONCOURSE
4B	TRAVEL CONCOURSE
4C	TRAVEL CONCOURSE
4D	TRAVEL CONCOURSE
4E	TRAVEL CONCOURSE
4F	TRAVEL CONCOURSE
4G	TRAVEL CONCOURSE
4H	TRAVEL CONCOURSE
4I	TRAVEL CONCOURSE
4J	TRAVEL CONCOURSE
4K	TRAVEL CONCOURSE
4L	TRAVEL CONCOURSE
4M	TRAVEL CONCOURSE
4N	TRAVEL CONCOURSE
4O	TRAVEL CONCOURSE
4P	TRAVEL CONCOURSE
4Q	TRAVEL CONCOURSE
4R	TRAVEL CONCOURSE
4S	TRAVEL CONCOURSE
4T	TRAVEL CONCOURSE
4U	TRAVEL CONCOURSE
4V	TRAVEL CONCOURSE
4W	TRAVEL CONCOURSE
4X	TRAVEL CONCOURSE
4Y	TRAVEL CONCOURSE
4Z	TRAVEL CONCOURSE
5A	TRAVEL CONCOURSE
5B	TRAVEL CONCOURSE
5C	TRAVEL CONCOURSE
5D	TRAVEL CONCOURSE
5E	TRAVEL CONCOURSE
5F	TRAVEL CONCOURSE
5G	TRAVEL CONCOURSE
5H	TRAVEL CONCOURSE
5I	TRAVEL CONCOURSE
5J	TRAVEL CONCOURSE
5K	TRAVEL CONCOURSE
5L	TRAVEL CONCOURSE
5M	TRAVEL CONCOURSE
5N	TRAVEL CONCOURSE
5O	TRAVEL CONCOURSE
5P	TRAVEL CONCOURSE
5Q	TRAVEL CONCOURSE
5R	TRAVEL CONCOURSE
5S	TRAVEL CONCOURSE
5T	TRAVEL CONCOURSE
5U	TRAVEL CONCOURSE
5V	TRAVEL CONCOURSE
5W	TRAVEL CONCOURSE
5X	TRAVEL CONCOURSE
5Y	TRAVEL CONCOURSE
5Z	TRAVEL CONCOURSE
6A	TRAVEL CONCOURSE
6B	TRAVEL CONCOURSE
6C	TRAVEL CONCOURSE
6D	TRAVEL CONCOURSE
6E	TRAVEL CONCOURSE
6F	TRAVEL CONCOURSE
6G	TRAVEL CONCOURSE
6H	TRAVEL CONCOURSE
6I	TRAVEL CONCOURSE
6J	TRAVEL CONCOURSE
6K	TRAVEL CONCOURSE
6L	TRAVEL CONCOURSE
6M	TRAVEL CONCOURSE
6N	TRAVEL CONCOURSE
6O	TRAVEL CONCOURSE
6P	TRAVEL CONCOURSE
6Q	TRAVEL CONCOURSE
6R	TRAVEL CONCOURSE
6S	TRAVEL CONCOURSE
6T	TRAVEL CONCOURSE
6U	TRAVEL CONCOURSE
6V	TRAVEL CONCOURSE
6W	TRAVEL CONCOURSE
6X	TRAVEL CONCOURSE
6Y	TRAVEL CONCOURSE
6Z	TRAVEL CONCOURSE
7A	TRAVEL CONCOURSE
7B	TRAVEL CONCOURSE
7C	TRAVEL CONCOURSE
7D	TRAVEL CONCOURSE
7E	TRAVEL CONCOURSE
7F	TRAVEL CONCOURSE
7G	TRAVEL CONCOURSE
7H	TRAVEL CONCOURSE
7I	TRAVEL CONCOURSE
7J	TRAVEL CONCOURSE
7K	TRAVEL CONCOURSE
7L	TRAVEL CONCOURSE
7M	TRAVEL CONCOURSE
7N	TRAVEL CONCOURSE
7O	TRAVEL CONCOURSE
7P	TRAVEL CONCOURSE
7Q	TRAVEL CONCOURSE
7R	TRAVEL CONCOURSE
7S	TRAVEL CONCOURSE
7T	TRAVEL CONCOURSE
7U	TRAVEL CONCOURSE
7V	TRAVEL CONCOURSE
7W	TRAVEL CONCOURSE
7X	TRAVEL CONCOURSE
7Y	TRAVEL CONCOURSE
7Z	TRAVEL CONCOURSE
8A	TRAVEL CONCOURSE
8B	TRAVEL CONCOURSE
8C	TRAVEL CONCOURSE
8D	TRAVEL CONCOURSE
8E	TRAVEL CONCOURSE
8F	TRAVEL CONCOURSE
8G	TRAVEL CONCOURSE
8H	TRAVEL CONCOURSE
8I	TRAVEL CONCOURSE
8J	TRAVEL CONCOURSE
8K	TRAVEL CONCOURSE
8L	TRAVEL CONCOURSE
8M	TRAVEL CONCOURSE
8N	TRAVEL CONCOURSE
8O	TRAVEL CONCOURSE
8P	TRAVEL CONCOURSE
8Q	TRAVEL CONCOURSE
8R	TRAVEL CONCOURSE
8S	TRAVEL CONCOURSE
8T	TRAVEL CONCOURSE
8U	TRAVEL CONCOURSE
8V	TRAVEL CONCOURSE
8W	TRAVEL CONCOURSE
8X	TRAVEL CONCOURSE
8Y	TRAVEL CONCOURSE
8Z	TRAVEL CONCOURSE
9A	TRAVEL CONCOURSE
9B	TRAVEL CONCOURSE
9C	TRAVEL CONCOURSE
9D	TRAVEL CONCOURSE
9E	TRAVEL CONCOURSE
9F	TRAVEL CONCOURSE
9G	TRAVEL CONCOURSE
9H	TRAVEL CONCOURSE
9I	TRAVEL CONCOURSE
9J	TRAVEL CONCOURSE
9K	TRAVEL CONCOURSE
9L	TRAVEL CONCOURSE
9M	TRAVEL CONCOURSE
9N	TRAVEL CONCOURSE
9O	TRAVEL CONCOURSE
9P	TRAVEL CONCOURSE
9Q	TRAVEL CONCOURSE
9R	TRAVEL CONCOURSE
9S	TRAVEL CONCOURSE
9T	TRAVEL CONCOURSE
9U	TRAVEL CONCOURSE
9V	TRAVEL CONCOURSE
9W	TRAVEL CONCOURSE
9X	TRAVEL CONCOURSE
9Y	TRAVEL CONCOURSE
9Z	TRAVEL CONCOURSE
10A	TRAVEL CONCOURSE
10B	TRAVEL CONCOURSE
10C	TRAVEL CONCOURSE
10D	TRAVEL CONCOURSE
10E	TRAVEL CONCOURSE
10F	TRAVEL CONCOURSE
10G	TRAVEL CONCOURSE
10H	TRAVEL CONCOURSE
10I	TRAVEL CONCOURSE
10J	TRAVEL CONCOURSE
10K	TRAVEL CONCOURSE
10L	TRAVEL CONCOURSE
10M	TRAVEL CONCOURSE
10N	TRAVEL CONCOURSE
10O	TRAVEL CONCOURSE
10P	TRAVEL CONCOURSE
10Q	TRAVEL CONCOURSE
10R	TRAVEL CONCOURSE
10S	TRAVEL CONCOURSE
10T	TRAVEL CONCOURSE
10U	TRAVEL CONCOURSE
10V	TRAVEL CONCOURSE
10W	TRAVEL CONCOURSE
10X	TRAVEL CONCOURSE
10Y	TRAVEL CONCOURSE
10Z	TRAVEL CONCOURSE

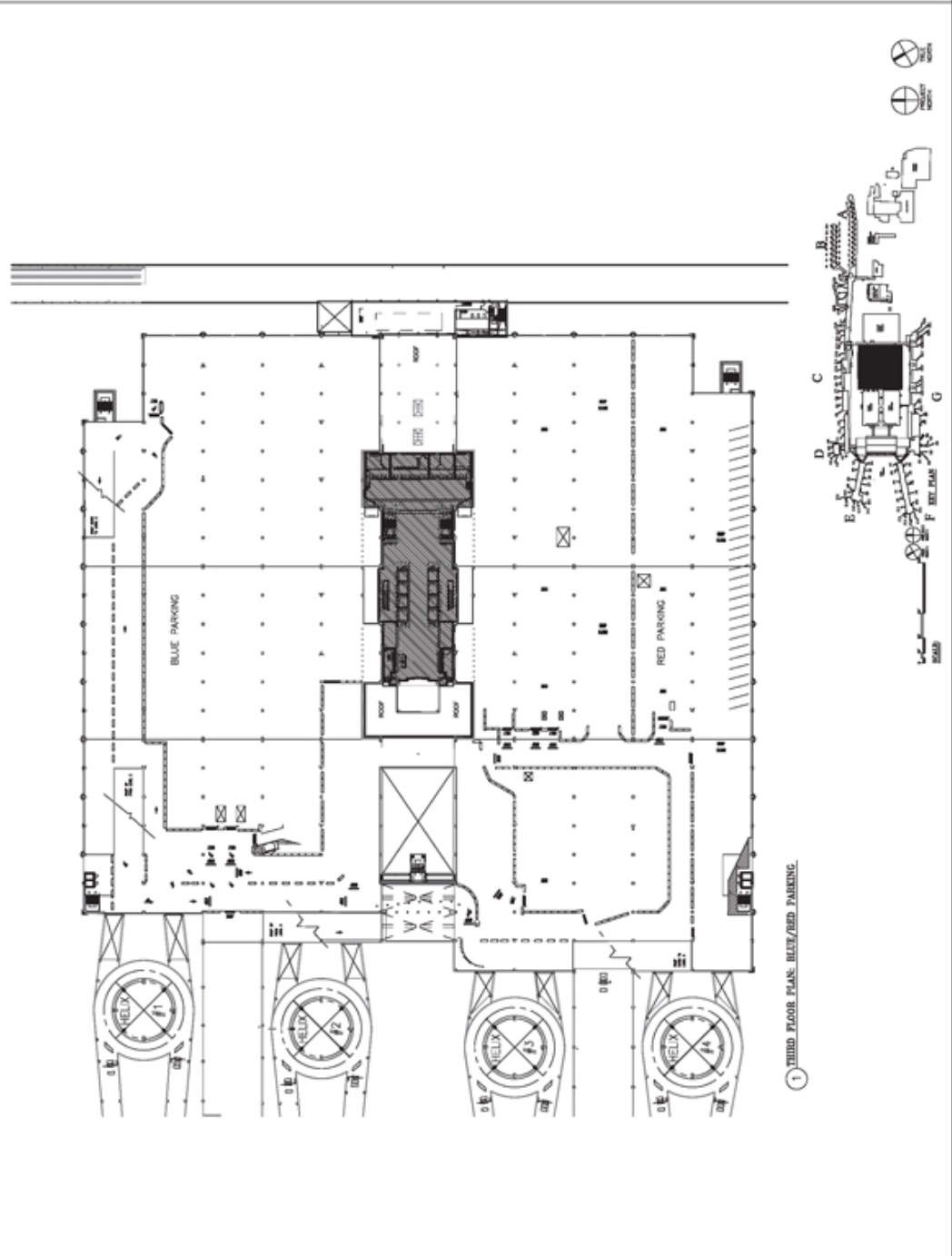

# EXHIBIT C

Date : JANUARY 1, 2019  
 Page 26 of 28

LEGEND  
 TERMINAL BUILDING AREA



Metropolitan Airports Commission  
 6040 29th Avenue So.  
 Minneapolis, MN 55416



**Space Category Key**

1A	PUBLIC CONCOURSE
1B	PUBLIC CONCOURSE
1C	PUBLIC CONCOURSE
1D	PUBLIC CONCOURSE
1E	PUBLIC CONCOURSE
1F	PUBLIC CONCOURSE
1G	PUBLIC CONCOURSE
1H	PUBLIC CONCOURSE
1I	PUBLIC CONCOURSE
1J	PUBLIC CONCOURSE
1K	PUBLIC CONCOURSE
1L	PUBLIC CONCOURSE
1M	PUBLIC CONCOURSE
1N	PUBLIC CONCOURSE
1O	PUBLIC CONCOURSE
1P	PUBLIC CONCOURSE
1Q	PUBLIC CONCOURSE
1R	PUBLIC CONCOURSE
1S	PUBLIC CONCOURSE
1T	PUBLIC CONCOURSE
1U	PUBLIC CONCOURSE
1V	PUBLIC CONCOURSE
1W	PUBLIC CONCOURSE
1X	PUBLIC CONCOURSE
1Y	PUBLIC CONCOURSE
1Z	PUBLIC CONCOURSE
2A	NON-ARRIVAL CONCOURSE
2B	NON-ARRIVAL CONCOURSE
2C	NON-ARRIVAL CONCOURSE
2D	NON-ARRIVAL CONCOURSE
2E	NON-ARRIVAL CONCOURSE
2F	NON-ARRIVAL CONCOURSE
2G	NON-ARRIVAL CONCOURSE
2H	NON-ARRIVAL CONCOURSE
2I	NON-ARRIVAL CONCOURSE
2J	NON-ARRIVAL CONCOURSE
2K	NON-ARRIVAL CONCOURSE
2L	NON-ARRIVAL CONCOURSE
2M	NON-ARRIVAL CONCOURSE
2N	NON-ARRIVAL CONCOURSE
2O	NON-ARRIVAL CONCOURSE
2P	NON-ARRIVAL CONCOURSE
2Q	NON-ARRIVAL CONCOURSE
2R	NON-ARRIVAL CONCOURSE
2S	NON-ARRIVAL CONCOURSE
2T	NON-ARRIVAL CONCOURSE
2U	NON-ARRIVAL CONCOURSE
2V	NON-ARRIVAL CONCOURSE
2W	NON-ARRIVAL CONCOURSE
2X	NON-ARRIVAL CONCOURSE
2Y	NON-ARRIVAL CONCOURSE
2Z	NON-ARRIVAL CONCOURSE
3A	NON-ARRIVAL CONCOURSE
3B	NON-ARRIVAL CONCOURSE
3C	NON-ARRIVAL CONCOURSE
3D	NON-ARRIVAL CONCOURSE
3E	NON-ARRIVAL CONCOURSE
3F	NON-ARRIVAL CONCOURSE
3G	NON-ARRIVAL CONCOURSE
3H	NON-ARRIVAL CONCOURSE
3I	NON-ARRIVAL CONCOURSE
3J	NON-ARRIVAL CONCOURSE
3K	NON-ARRIVAL CONCOURSE
3L	NON-ARRIVAL CONCOURSE
3M	NON-ARRIVAL CONCOURSE
3N	NON-ARRIVAL CONCOURSE
3O	NON-ARRIVAL CONCOURSE
3P	NON-ARRIVAL CONCOURSE
3Q	NON-ARRIVAL CONCOURSE
3R	NON-ARRIVAL CONCOURSE
3S	NON-ARRIVAL CONCOURSE
3T	NON-ARRIVAL CONCOURSE
3U	NON-ARRIVAL CONCOURSE
3V	NON-ARRIVAL CONCOURSE
3W	NON-ARRIVAL CONCOURSE
3X	NON-ARRIVAL CONCOURSE
3Y	NON-ARRIVAL CONCOURSE
3Z	NON-ARRIVAL CONCOURSE
4A	NON-ARRIVAL CONCOURSE
4B	NON-ARRIVAL CONCOURSE
4C	NON-ARRIVAL CONCOURSE
4D	NON-ARRIVAL CONCOURSE
4E	NON-ARRIVAL CONCOURSE
4F	NON-ARRIVAL CONCOURSE
4G	NON-ARRIVAL CONCOURSE
4H	NON-ARRIVAL CONCOURSE
4I	NON-ARRIVAL CONCOURSE
4J	NON-ARRIVAL CONCOURSE
4K	NON-ARRIVAL CONCOURSE
4L	NON-ARRIVAL CONCOURSE
4M	NON-ARRIVAL CONCOURSE
4N	NON-ARRIVAL CONCOURSE
4O	NON-ARRIVAL CONCOURSE
4P	NON-ARRIVAL CONCOURSE
4Q	NON-ARRIVAL CONCOURSE
4R	NON-ARRIVAL CONCOURSE
4S	NON-ARRIVAL CONCOURSE
4T	NON-ARRIVAL CONCOURSE
4U	NON-ARRIVAL CONCOURSE
4V	NON-ARRIVAL CONCOURSE
4W	NON-ARRIVAL CONCOURSE
4X	NON-ARRIVAL CONCOURSE
4Y	NON-ARRIVAL CONCOURSE
4Z	NON-ARRIVAL CONCOURSE

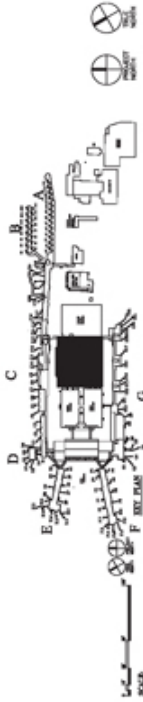
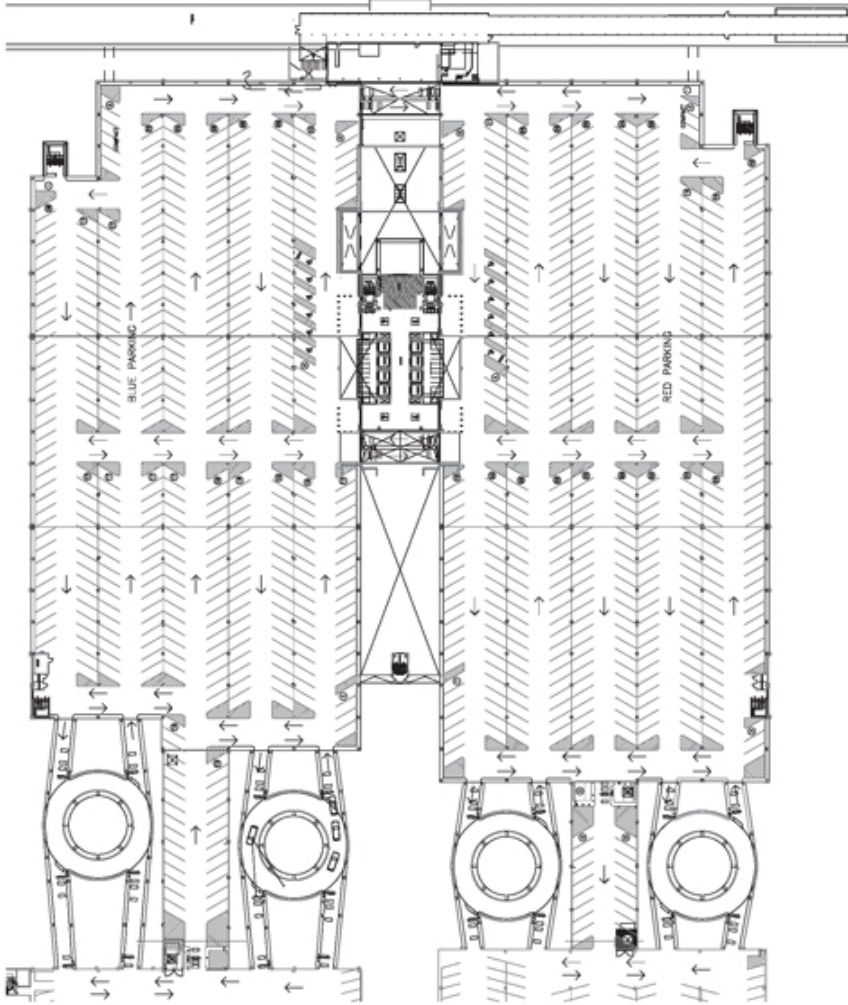

① FOURTH FLOOR PLANS: BLUE/RED PARKING



MINNEAPOLIS / ST. PAUL  
 INTERNATIONAL AIRPORT  
 TERMINAL BUILDING

HUB AREA  
 FOURTH FLOOR





**Minneapolis-St. Paul International Airport  
Airline Operating Agreement and Terminal Building Lease  
Exhibit D**

**TERMINAL APRON EFFECTIVE JANUARY 1, 2019**

<u>Airline</u>	<u>January 1, 2019</u>
American (E11, E12, E13, E14, E15, E16)	590
Frontier (E3)	139
MAC (E1, B Hardstand)	219
Delta (A, B, C, D, F, G)	8,966
United (E5, E6, E7, E8, E9, E10)	785
Spirit (E2, E4)	302
<b>Total (lineal feet)</b>	<b><u>11,001</u></b>



# EXHIBIT D

Date : JANUARY 1, 2019  
 Page 1 of 2  
 LEGEND



TERMINAL APRON



Metropolitan Airports Commission  
 6010 29th Avenue So.  
 Minneapolis, MN 55410



- Space Category Key**
- 1A PUBLIC CONCOURSE
  - 1B PUBLIC CONCOURSE
  - 1C PUBLIC CONCOURSE
  - 2A AIRSIDE FOREST COVERED
  - 2B AIRSIDE BRIDGE
  - 2C AIRSIDE BRIDGE
  - 2D AIRSIDE BRIDGE
  - 2E AIRSIDE BRIDGE
  - 2F AIRSIDE BRIDGE
  - 2G AIRSIDE BRIDGE
  - 2H AIRSIDE BRIDGE
  - 2I AIRSIDE BRIDGE
  - 2J AIRSIDE BRIDGE
  - 2K AIRSIDE BRIDGE
  - 2L AIRSIDE BRIDGE
  - 2M AIRSIDE BRIDGE
  - 2N AIRSIDE BRIDGE
  - 2O AIRSIDE BRIDGE
  - 2P AIRSIDE BRIDGE
  - 2Q AIRSIDE BRIDGE
  - 2R AIRSIDE BRIDGE
  - 2S AIRSIDE BRIDGE
  - 2T AIRSIDE BRIDGE
  - 2U AIRSIDE BRIDGE
  - 2V AIRSIDE BRIDGE
  - 2W AIRSIDE BRIDGE
  - 2X AIRSIDE BRIDGE
  - 2Y AIRSIDE BRIDGE
  - 2Z AIRSIDE BRIDGE
  - 3A AIRSIDE BRIDGE
  - 3B AIRSIDE BRIDGE
  - 3C AIRSIDE BRIDGE
  - 3D AIRSIDE BRIDGE
  - 3E AIRSIDE BRIDGE
  - 3F AIRSIDE BRIDGE
  - 3G AIRSIDE BRIDGE
  - 3H AIRSIDE BRIDGE
  - 3I AIRSIDE BRIDGE
  - 3J AIRSIDE BRIDGE
  - 3K AIRSIDE BRIDGE
  - 3L AIRSIDE BRIDGE
  - 3M AIRSIDE BRIDGE
  - 3N AIRSIDE BRIDGE
  - 3O AIRSIDE BRIDGE
  - 3P AIRSIDE BRIDGE
  - 3Q AIRSIDE BRIDGE
  - 3R AIRSIDE BRIDGE
  - 3S AIRSIDE BRIDGE
  - 3T AIRSIDE BRIDGE
  - 3U AIRSIDE BRIDGE
  - 3V AIRSIDE BRIDGE
  - 3W AIRSIDE BRIDGE
  - 3X AIRSIDE BRIDGE
  - 3Y AIRSIDE BRIDGE
  - 3Z AIRSIDE BRIDGE
  - 4A AIRSIDE BRIDGE
  - 4B AIRSIDE BRIDGE
  - 4C AIRSIDE BRIDGE
  - 4D AIRSIDE BRIDGE
  - 4E AIRSIDE BRIDGE
  - 4F AIRSIDE BRIDGE
  - 4G AIRSIDE BRIDGE
  - 4H AIRSIDE BRIDGE
  - 4I AIRSIDE BRIDGE
  - 4J AIRSIDE BRIDGE
  - 4K AIRSIDE BRIDGE
  - 4L AIRSIDE BRIDGE
  - 4M AIRSIDE BRIDGE
  - 4N AIRSIDE BRIDGE
  - 4O AIRSIDE BRIDGE
  - 4P AIRSIDE BRIDGE
  - 4Q AIRSIDE BRIDGE
  - 4R AIRSIDE BRIDGE
  - 4S AIRSIDE BRIDGE
  - 4T AIRSIDE BRIDGE
  - 4U AIRSIDE BRIDGE
  - 4V AIRSIDE BRIDGE
  - 4W AIRSIDE BRIDGE
  - 4X AIRSIDE BRIDGE
  - 4Y AIRSIDE BRIDGE
  - 4Z AIRSIDE BRIDGE
  - 5A AIRSIDE BRIDGE
  - 5B AIRSIDE BRIDGE
  - 5C AIRSIDE BRIDGE
  - 5D AIRSIDE BRIDGE
  - 5E AIRSIDE BRIDGE
  - 5F AIRSIDE BRIDGE
  - 5G AIRSIDE BRIDGE
  - 5H AIRSIDE BRIDGE
  - 5I AIRSIDE BRIDGE
  - 5J AIRSIDE BRIDGE
  - 5K AIRSIDE BRIDGE
  - 5L AIRSIDE BRIDGE
  - 5M AIRSIDE BRIDGE
  - 5N AIRSIDE BRIDGE
  - 5O AIRSIDE BRIDGE
  - 5P AIRSIDE BRIDGE
  - 5Q AIRSIDE BRIDGE
  - 5R AIRSIDE BRIDGE
  - 5S AIRSIDE BRIDGE
  - 5T AIRSIDE BRIDGE
  - 5U AIRSIDE BRIDGE
  - 5V AIRSIDE BRIDGE
  - 5W AIRSIDE BRIDGE
  - 5X AIRSIDE BRIDGE
  - 5Y AIRSIDE BRIDGE
  - 5Z AIRSIDE BRIDGE
  - 6A AIRSIDE BRIDGE
  - 6B AIRSIDE BRIDGE
  - 6C AIRSIDE BRIDGE
  - 6D AIRSIDE BRIDGE
  - 6E AIRSIDE BRIDGE
  - 6F AIRSIDE BRIDGE
  - 6G AIRSIDE BRIDGE
  - 6H AIRSIDE BRIDGE
  - 6I AIRSIDE BRIDGE
  - 6J AIRSIDE BRIDGE
  - 6K AIRSIDE BRIDGE
  - 6L AIRSIDE BRIDGE
  - 6M AIRSIDE BRIDGE
  - 6N AIRSIDE BRIDGE
  - 6O AIRSIDE BRIDGE
  - 6P AIRSIDE BRIDGE
  - 6Q AIRSIDE BRIDGE
  - 6R AIRSIDE BRIDGE
  - 6S AIRSIDE BRIDGE
  - 6T AIRSIDE BRIDGE
  - 6U AIRSIDE BRIDGE
  - 6V AIRSIDE BRIDGE
  - 6W AIRSIDE BRIDGE
  - 6X AIRSIDE BRIDGE
  - 6Y AIRSIDE BRIDGE
  - 6Z AIRSIDE BRIDGE
  - 7A AIRSIDE BRIDGE
  - 7B AIRSIDE BRIDGE
  - 7C AIRSIDE BRIDGE
  - 7D AIRSIDE BRIDGE
  - 7E AIRSIDE BRIDGE
  - 7F AIRSIDE BRIDGE
  - 7G AIRSIDE BRIDGE
  - 7H AIRSIDE BRIDGE
  - 7I AIRSIDE BRIDGE
  - 7J AIRSIDE BRIDGE
  - 7K AIRSIDE BRIDGE
  - 7L AIRSIDE BRIDGE
  - 7M AIRSIDE BRIDGE
  - 7N AIRSIDE BRIDGE
  - 7O AIRSIDE BRIDGE
  - 7P AIRSIDE BRIDGE
  - 7Q AIRSIDE BRIDGE
  - 7R AIRSIDE BRIDGE
  - 7S AIRSIDE BRIDGE
  - 7T AIRSIDE BRIDGE
  - 7U AIRSIDE BRIDGE
  - 7V AIRSIDE BRIDGE
  - 7W AIRSIDE BRIDGE
  - 7X AIRSIDE BRIDGE
  - 7Y AIRSIDE BRIDGE
  - 7Z AIRSIDE BRIDGE
  - 8A AIRSIDE BRIDGE
  - 8B AIRSIDE BRIDGE
  - 8C AIRSIDE BRIDGE
  - 8D AIRSIDE BRIDGE
  - 8E AIRSIDE BRIDGE
  - 8F AIRSIDE BRIDGE
  - 8G AIRSIDE BRIDGE
  - 8H AIRSIDE BRIDGE
  - 8I AIRSIDE BRIDGE
  - 8J AIRSIDE BRIDGE
  - 8K AIRSIDE BRIDGE
  - 8L AIRSIDE BRIDGE
  - 8M AIRSIDE BRIDGE
  - 8N AIRSIDE BRIDGE
  - 8O AIRSIDE BRIDGE
  - 8P AIRSIDE BRIDGE
  - 8Q AIRSIDE BRIDGE
  - 8R AIRSIDE BRIDGE
  - 8S AIRSIDE BRIDGE
  - 8T AIRSIDE BRIDGE
  - 8U AIRSIDE BRIDGE
  - 8V AIRSIDE BRIDGE
  - 8W AIRSIDE BRIDGE
  - 8X AIRSIDE BRIDGE
  - 8Y AIRSIDE BRIDGE
  - 8Z AIRSIDE BRIDGE
  - 9A AIRSIDE BRIDGE
  - 9B AIRSIDE BRIDGE
  - 9C AIRSIDE BRIDGE
  - 9D AIRSIDE BRIDGE
  - 9E AIRSIDE BRIDGE
  - 9F AIRSIDE BRIDGE
  - 9G AIRSIDE BRIDGE
  - 9H AIRSIDE BRIDGE
  - 9I AIRSIDE BRIDGE
  - 9J AIRSIDE BRIDGE
  - 9K AIRSIDE BRIDGE
  - 9L AIRSIDE BRIDGE
  - 9M AIRSIDE BRIDGE
  - 9N AIRSIDE BRIDGE
  - 9O AIRSIDE BRIDGE
  - 9P AIRSIDE BRIDGE
  - 9Q AIRSIDE BRIDGE
  - 9R AIRSIDE BRIDGE
  - 9S AIRSIDE BRIDGE
  - 9T AIRSIDE BRIDGE
  - 9U AIRSIDE BRIDGE
  - 9V AIRSIDE BRIDGE
  - 9W AIRSIDE BRIDGE
  - 9X AIRSIDE BRIDGE
  - 9Y AIRSIDE BRIDGE
  - 9Z AIRSIDE BRIDGE
  - 10A AIRSIDE BRIDGE
  - 10B AIRSIDE BRIDGE
  - 10C AIRSIDE BRIDGE
  - 10D AIRSIDE BRIDGE
  - 10E AIRSIDE BRIDGE
  - 10F AIRSIDE BRIDGE
  - 10G AIRSIDE BRIDGE
  - 10H AIRSIDE BRIDGE
  - 10I AIRSIDE BRIDGE
  - 10J AIRSIDE BRIDGE
  - 10K AIRSIDE BRIDGE
  - 10L AIRSIDE BRIDGE
  - 10M AIRSIDE BRIDGE
  - 10N AIRSIDE BRIDGE
  - 10O AIRSIDE BRIDGE
  - 10P AIRSIDE BRIDGE
  - 10Q AIRSIDE BRIDGE
  - 10R AIRSIDE BRIDGE
  - 10S AIRSIDE BRIDGE
  - 10T AIRSIDE BRIDGE
  - 10U AIRSIDE BRIDGE
  - 10V AIRSIDE BRIDGE
  - 10W AIRSIDE BRIDGE
  - 10X AIRSIDE BRIDGE
  - 10Y AIRSIDE BRIDGE
  - 10Z AIRSIDE BRIDGE

MINNEAPOLIS/ST. PAUL INTERNATIONAL AIRPORT  
**TERMINAL APRON DETAIL**

FM001

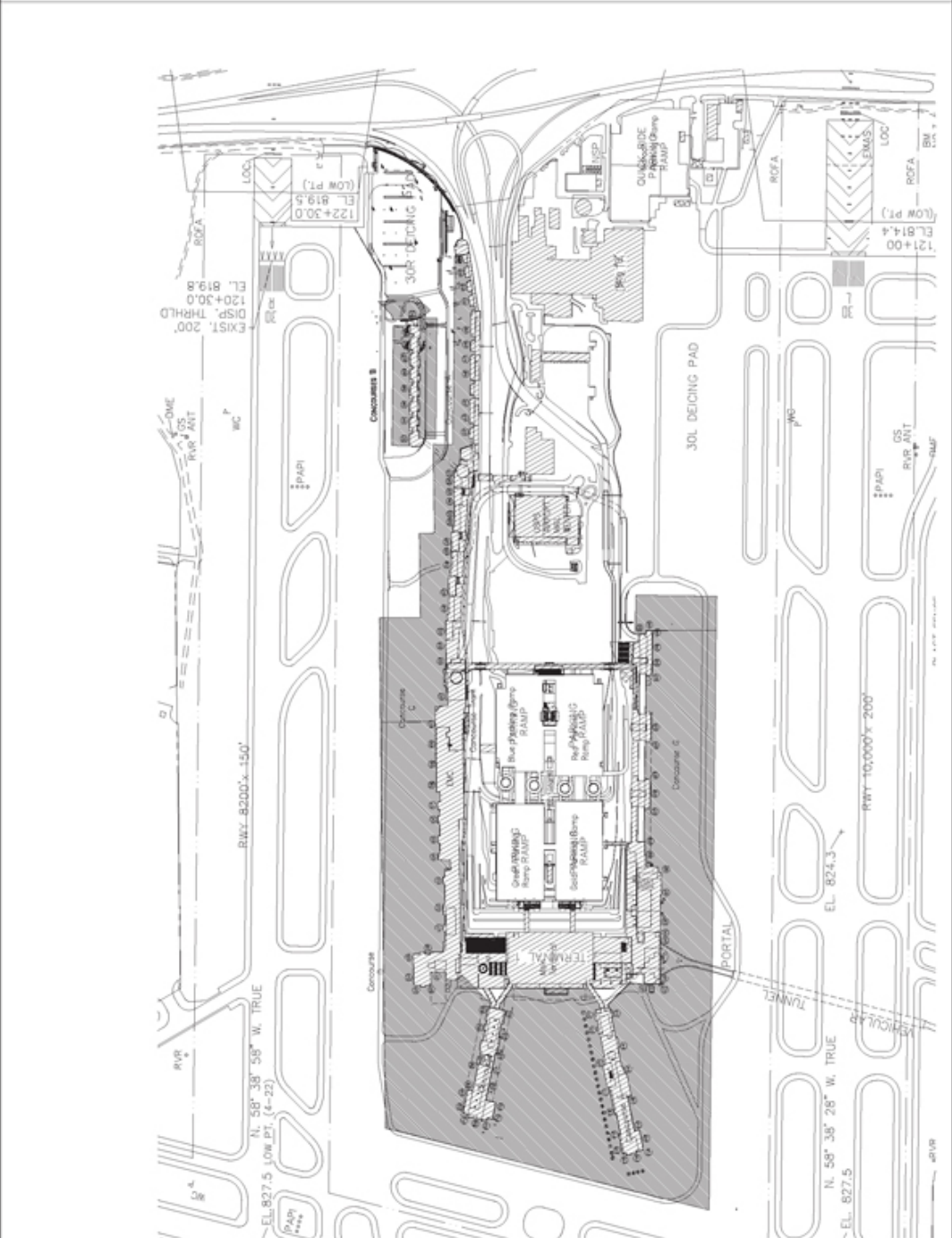





# EXHIBIT E

Date : JANUARY 1, 2019  
 Page 1 of 4

LEGEND  
 TERMINAL BUILDING AREA



Metropolitan Airports Commission  
 6040 29th Avenue So.  
 Minneapolis, MN 55416



**Space Category Key**

1A	PUBLIC CONCOURSE
1B	PUBLIC CONCOURSE
1C	PUBLIC CONCOURSE
1D	PUBLIC CONCOURSE
1E	PUBLIC CONCOURSE
1F	PUBLIC CONCOURSE
1G	PUBLIC CONCOURSE
1H	PUBLIC CONCOURSE
1I	PUBLIC CONCOURSE
1J	PUBLIC CONCOURSE
1K	PUBLIC CONCOURSE
1L	PUBLIC CONCOURSE
1M	PUBLIC CONCOURSE
1N	PUBLIC CONCOURSE
1O	PUBLIC CONCOURSE
1P	PUBLIC CONCOURSE
1Q	PUBLIC CONCOURSE
1R	PUBLIC CONCOURSE
1S	PUBLIC CONCOURSE
1T	PUBLIC CONCOURSE
1U	PUBLIC CONCOURSE
1V	PUBLIC CONCOURSE
1W	PUBLIC CONCOURSE
1X	PUBLIC CONCOURSE
1Y	PUBLIC CONCOURSE
1Z	PUBLIC CONCOURSE
2A	NON-ADJACENT CONCOURSE
2B	NON-ADJACENT CONCOURSE
2C	NON-ADJACENT CONCOURSE
2D	NON-ADJACENT CONCOURSE
2E	NON-ADJACENT CONCOURSE
2F	NON-ADJACENT CONCOURSE
2G	NON-ADJACENT CONCOURSE
2H	NON-ADJACENT CONCOURSE
2I	NON-ADJACENT CONCOURSE
2J	NON-ADJACENT CONCOURSE
2K	NON-ADJACENT CONCOURSE
2L	NON-ADJACENT CONCOURSE
2M	NON-ADJACENT CONCOURSE
2N	NON-ADJACENT CONCOURSE
2O	NON-ADJACENT CONCOURSE
2P	NON-ADJACENT CONCOURSE
2Q	NON-ADJACENT CONCOURSE
2R	NON-ADJACENT CONCOURSE
2S	NON-ADJACENT CONCOURSE
2T	NON-ADJACENT CONCOURSE
2U	NON-ADJACENT CONCOURSE
2V	NON-ADJACENT CONCOURSE
2W	NON-ADJACENT CONCOURSE
2X	NON-ADJACENT CONCOURSE
2Y	NON-ADJACENT CONCOURSE
2Z	NON-ADJACENT CONCOURSE
3A	NON-ADJACENT CONCOURSE
3B	NON-ADJACENT CONCOURSE
3C	NON-ADJACENT CONCOURSE
3D	NON-ADJACENT CONCOURSE
3E	NON-ADJACENT CONCOURSE
3F	NON-ADJACENT CONCOURSE
3G	NON-ADJACENT CONCOURSE
3H	NON-ADJACENT CONCOURSE
3I	NON-ADJACENT CONCOURSE
3J	NON-ADJACENT CONCOURSE
3K	NON-ADJACENT CONCOURSE
3L	NON-ADJACENT CONCOURSE
3M	NON-ADJACENT CONCOURSE
3N	NON-ADJACENT CONCOURSE
3O	NON-ADJACENT CONCOURSE
3P	NON-ADJACENT CONCOURSE
3Q	NON-ADJACENT CONCOURSE
3R	NON-ADJACENT CONCOURSE
3S	NON-ADJACENT CONCOURSE
3T	NON-ADJACENT CONCOURSE
3U	NON-ADJACENT CONCOURSE
3V	NON-ADJACENT CONCOURSE
3W	NON-ADJACENT CONCOURSE
3X	NON-ADJACENT CONCOURSE
3Y	NON-ADJACENT CONCOURSE
3Z	NON-ADJACENT CONCOURSE
4A	NON-ADJACENT CONCOURSE
4B	NON-ADJACENT CONCOURSE
4C	NON-ADJACENT CONCOURSE
4D	NON-ADJACENT CONCOURSE
4E	NON-ADJACENT CONCOURSE
4F	NON-ADJACENT CONCOURSE
4G	NON-ADJACENT CONCOURSE
4H	NON-ADJACENT CONCOURSE
4I	NON-ADJACENT CONCOURSE
4J	NON-ADJACENT CONCOURSE
4K	NON-ADJACENT CONCOURSE
4L	NON-ADJACENT CONCOURSE
4M	NON-ADJACENT CONCOURSE
4N	NON-ADJACENT CONCOURSE
4O	NON-ADJACENT CONCOURSE
4P	NON-ADJACENT CONCOURSE
4Q	NON-ADJACENT CONCOURSE
4R	NON-ADJACENT CONCOURSE
4S	NON-ADJACENT CONCOURSE
4T	NON-ADJACENT CONCOURSE
4U	NON-ADJACENT CONCOURSE
4V	NON-ADJACENT CONCOURSE
4W	NON-ADJACENT CONCOURSE
4X	NON-ADJACENT CONCOURSE
4Y	NON-ADJACENT CONCOURSE
4Z	NON-ADJACENT CONCOURSE

MINNEAPOLIS/ST. PAUL INTERNATIONAL AIRPORT  
 HUMPHREY TERMINAL  
 FM000

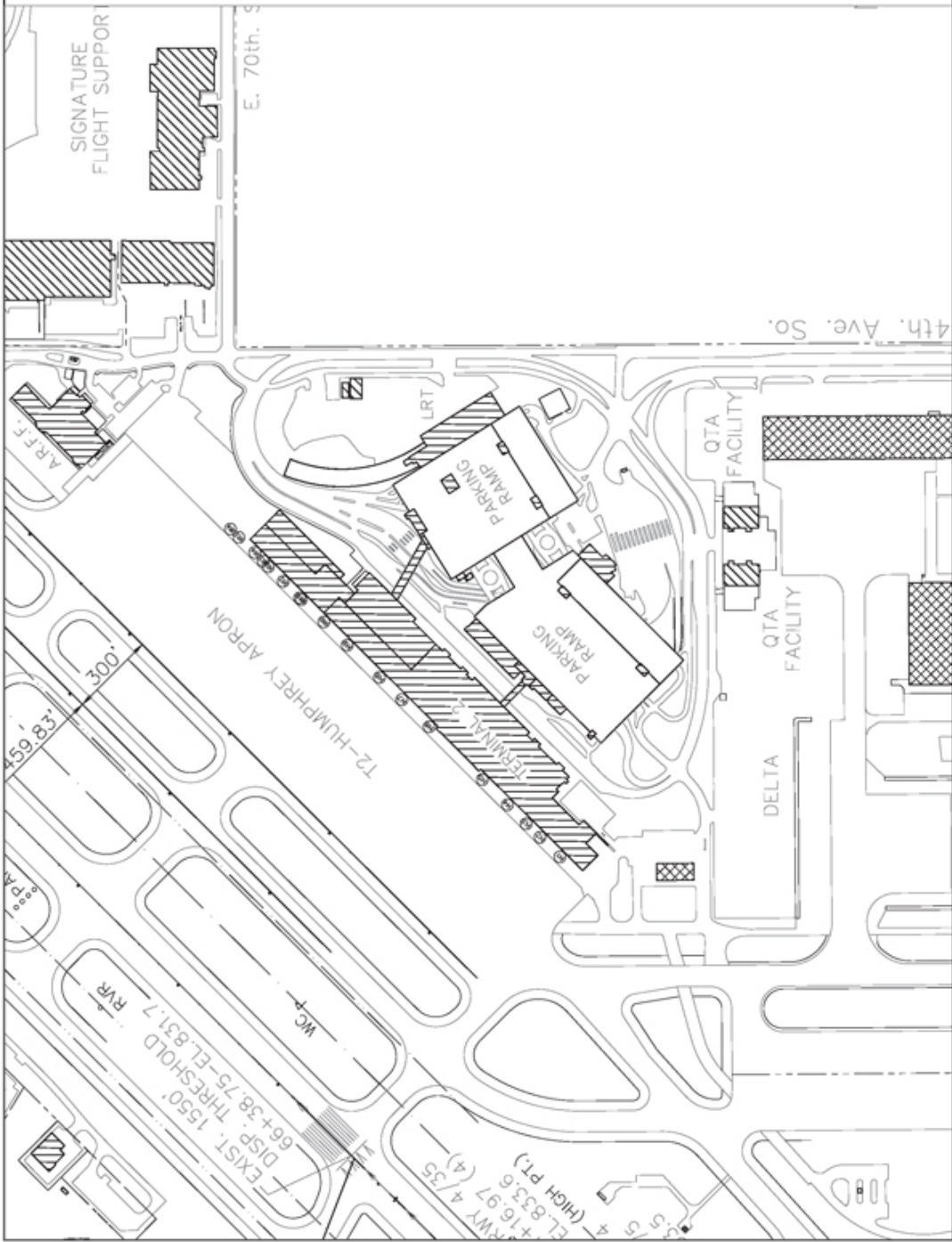



**EXHIBIT E**

Date : JANUARY 1, 2019  
 Page 3 of 4

LEGEND  
 TERMINAL BUILDING AREA



Metropolitan  
 Airports  
 Commission  
 6040 29th Avenue So.  
 Minneapolis, MN 55416

Space Category Key

1	TRAVEL NAME
2	TRAVEL NAME
3	TRAVEL NAME
4	TRAVEL NAME
5	TRAVEL NAME
6	TRAVEL NAME
7	TRAVEL NAME
8	TRAVEL NAME
9	TRAVEL NAME
10	TRAVEL NAME
11	TRAVEL NAME
12	TRAVEL NAME
13	TRAVEL NAME
14	TRAVEL NAME
15	TRAVEL NAME
16	TRAVEL NAME
17	TRAVEL NAME
18	TRAVEL NAME
19	TRAVEL NAME
20	TRAVEL NAME
21	TRAVEL NAME
22	TRAVEL NAME
23	TRAVEL NAME
24	TRAVEL NAME
25	TRAVEL NAME
26	TRAVEL NAME
27	TRAVEL NAME
28	TRAVEL NAME
29	TRAVEL NAME
30	TRAVEL NAME
31	TRAVEL NAME
32	TRAVEL NAME
33	TRAVEL NAME
34	TRAVEL NAME
35	TRAVEL NAME
36	TRAVEL NAME
37	TRAVEL NAME
38	TRAVEL NAME
39	TRAVEL NAME
40	TRAVEL NAME
41	TRAVEL NAME
42	TRAVEL NAME
43	TRAVEL NAME
44	TRAVEL NAME
45	TRAVEL NAME
46	TRAVEL NAME
47	TRAVEL NAME
48	TRAVEL NAME
49	TRAVEL NAME
50	TRAVEL NAME
51	TRAVEL NAME
52	TRAVEL NAME
53	TRAVEL NAME
54	TRAVEL NAME
55	TRAVEL NAME
56	TRAVEL NAME
57	TRAVEL NAME
58	TRAVEL NAME
59	TRAVEL NAME
60	TRAVEL NAME
61	TRAVEL NAME
62	TRAVEL NAME
63	TRAVEL NAME
64	TRAVEL NAME
65	TRAVEL NAME
66	TRAVEL NAME
67	TRAVEL NAME
68	TRAVEL NAME
69	TRAVEL NAME
70	TRAVEL NAME
71	TRAVEL NAME
72	TRAVEL NAME
73	TRAVEL NAME
74	TRAVEL NAME
75	TRAVEL NAME
76	TRAVEL NAME
77	TRAVEL NAME
78	TRAVEL NAME
79	TRAVEL NAME
80	TRAVEL NAME
81	TRAVEL NAME
82	TRAVEL NAME
83	TRAVEL NAME
84	TRAVEL NAME
85	TRAVEL NAME
86	TRAVEL NAME
87	TRAVEL NAME
88	TRAVEL NAME
89	TRAVEL NAME
90	TRAVEL NAME
91	TRAVEL NAME
92	TRAVEL NAME
93	TRAVEL NAME
94	TRAVEL NAME
95	TRAVEL NAME
96	TRAVEL NAME
97	TRAVEL NAME
98	TRAVEL NAME
99	TRAVEL NAME
100	TRAVEL NAME

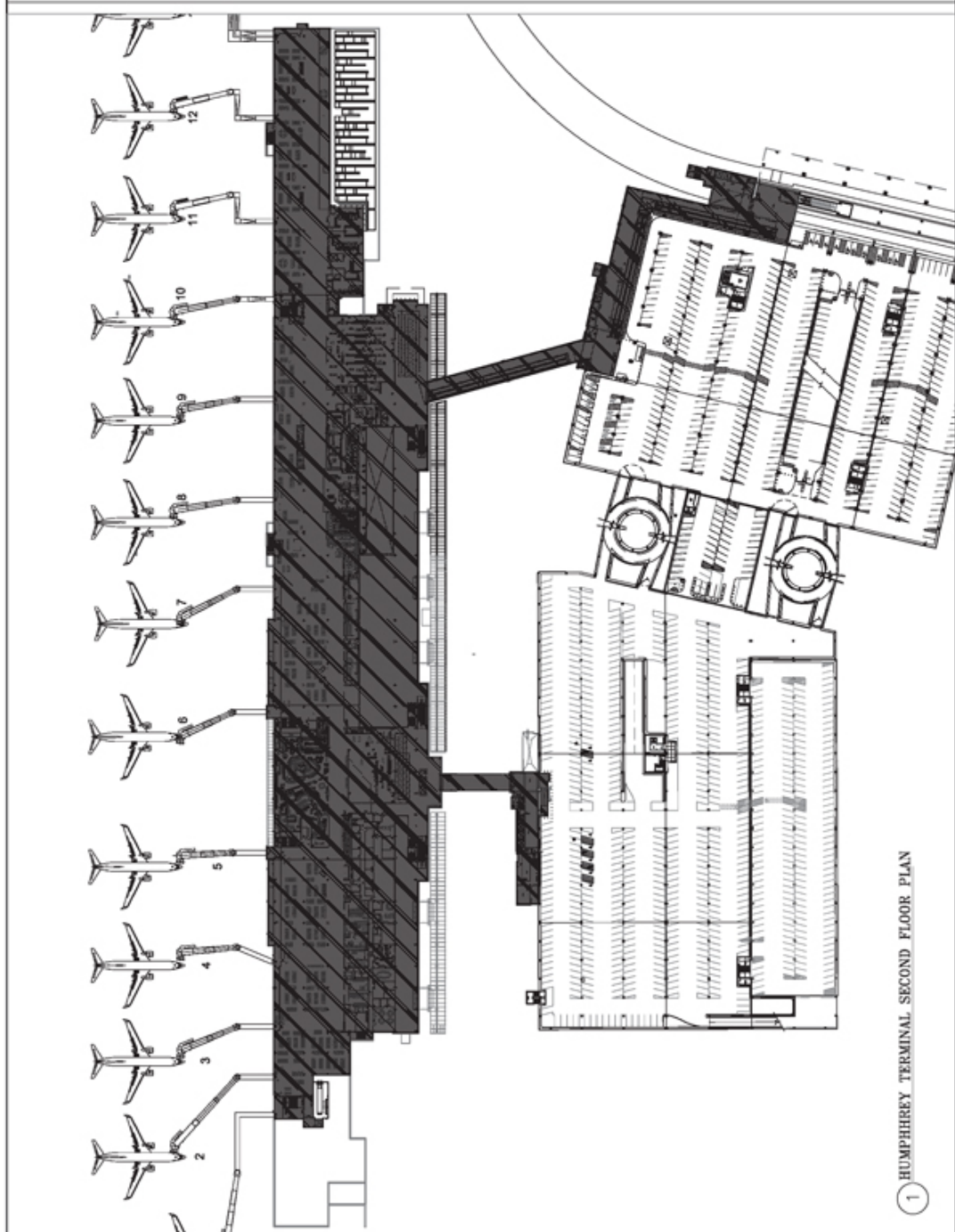

1 HUMPHREY TERMINAL SECOND FLOOR PLAN

# EXHIBIT E

Date : JANUARY 1, 2019  
 Page 4 OF 4

LEGEND  
 TERMINAL BUILDING AREA



Metropolitan Airports Commission  
 6010 29th Avenue SE,  
 Minneapolis, MN 55410

Space Category Key

10	PUBLIC CONCOURSE
11	PUBLIC CONCOURSE
12	PUBLIC CONCOURSE
13	PUBLIC CONCOURSE
14	PUBLIC CONCOURSE
15	PUBLIC CONCOURSE
16	PUBLIC CONCOURSE
17	PUBLIC CONCOURSE
18	PUBLIC CONCOURSE
19	PUBLIC CONCOURSE
20	PUBLIC CONCOURSE
21	PUBLIC CONCOURSE
22	PUBLIC CONCOURSE
23	PUBLIC CONCOURSE
24	PUBLIC CONCOURSE
25	PUBLIC CONCOURSE
26	PUBLIC CONCOURSE
27	PUBLIC CONCOURSE
28	PUBLIC CONCOURSE
29	PUBLIC CONCOURSE
30	PUBLIC CONCOURSE
31	PUBLIC CONCOURSE
32	PUBLIC CONCOURSE
33	PUBLIC CONCOURSE
34	PUBLIC CONCOURSE
35	PUBLIC CONCOURSE
36	PUBLIC CONCOURSE
37	PUBLIC CONCOURSE
38	PUBLIC CONCOURSE
39	PUBLIC CONCOURSE
40	PUBLIC CONCOURSE
41	PUBLIC CONCOURSE
42	PUBLIC CONCOURSE
43	PUBLIC CONCOURSE
44	PUBLIC CONCOURSE
45	PUBLIC CONCOURSE
46	PUBLIC CONCOURSE
47	PUBLIC CONCOURSE
48	PUBLIC CONCOURSE
49	PUBLIC CONCOURSE
50	PUBLIC CONCOURSE
51	PUBLIC CONCOURSE
52	PUBLIC CONCOURSE
53	PUBLIC CONCOURSE
54	PUBLIC CONCOURSE
55	PUBLIC CONCOURSE
56	PUBLIC CONCOURSE
57	PUBLIC CONCOURSE
58	PUBLIC CONCOURSE
59	PUBLIC CONCOURSE
60	PUBLIC CONCOURSE
61	PUBLIC CONCOURSE
62	PUBLIC CONCOURSE
63	PUBLIC CONCOURSE
64	PUBLIC CONCOURSE
65	PUBLIC CONCOURSE
66	PUBLIC CONCOURSE
67	PUBLIC CONCOURSE
68	PUBLIC CONCOURSE
69	PUBLIC CONCOURSE
70	PUBLIC CONCOURSE
71	PUBLIC CONCOURSE
72	PUBLIC CONCOURSE
73	PUBLIC CONCOURSE
74	PUBLIC CONCOURSE
75	PUBLIC CONCOURSE
76	PUBLIC CONCOURSE
77	PUBLIC CONCOURSE
78	PUBLIC CONCOURSE
79	PUBLIC CONCOURSE
80	PUBLIC CONCOURSE
81	PUBLIC CONCOURSE
82	PUBLIC CONCOURSE
83	PUBLIC CONCOURSE
84	PUBLIC CONCOURSE
85	PUBLIC CONCOURSE
86	PUBLIC CONCOURSE
87	PUBLIC CONCOURSE
88	PUBLIC CONCOURSE
89	PUBLIC CONCOURSE
90	PUBLIC CONCOURSE
91	PUBLIC CONCOURSE
92	PUBLIC CONCOURSE
93	PUBLIC CONCOURSE
94	PUBLIC CONCOURSE
95	PUBLIC CONCOURSE
96	PUBLIC CONCOURSE
97	PUBLIC CONCOURSE
98	PUBLIC CONCOURSE
99	PUBLIC CONCOURSE
100	PUBLIC CONCOURSE

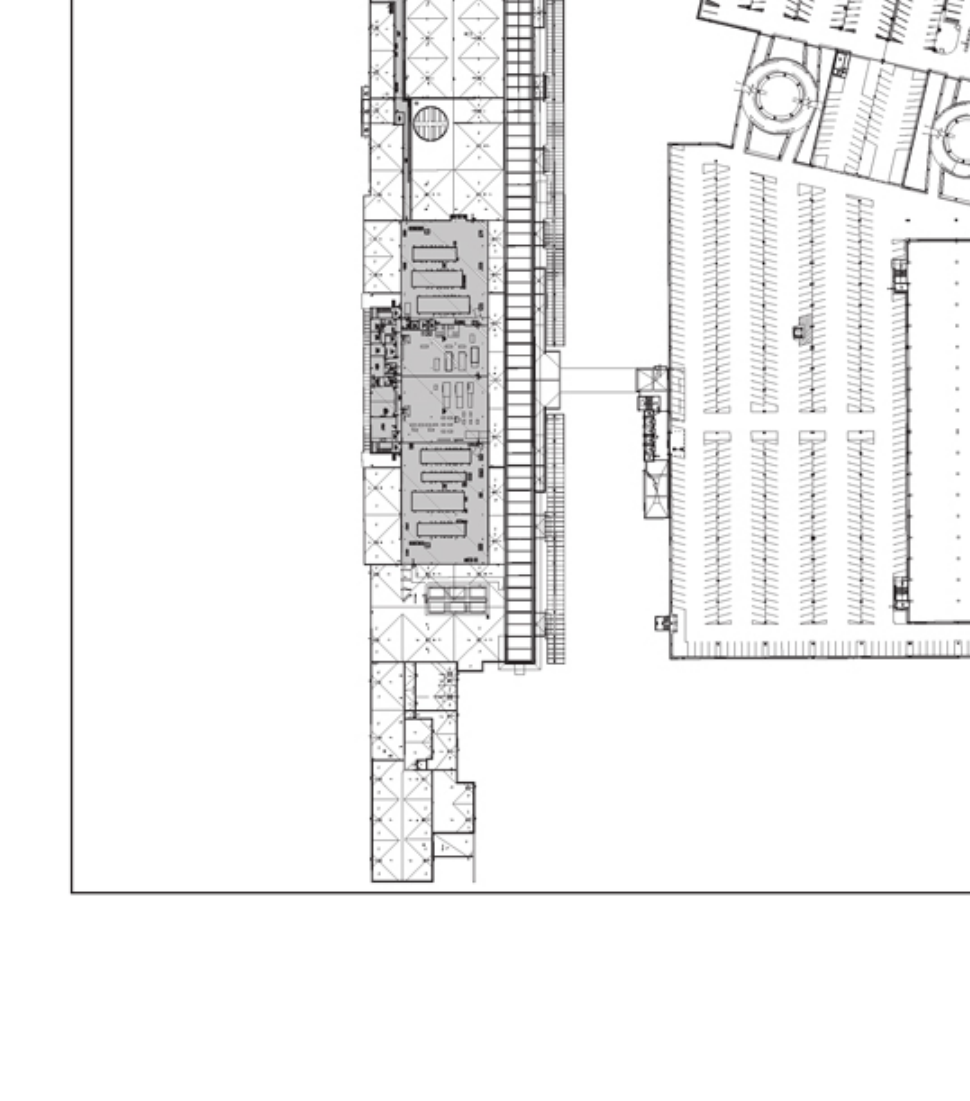

1 TERMINAL 2 THIRD FLOOR PLAN

MINNEAPOLIS / ST. PAUL INTERNATIONAL AIRPORT  
 HUMPHREY TERMINAL  
 THIRD FLOOR PLAN





**Other Areas**

Other Areas includes, but is not limited to, the following MAC facilities:

- Cargo Area
- Other Roads (Non AOA and Non Terminal Area)
- Hangars and Other Buildings (Includes any other MAC facility not flowing to airline rates and charges)

Exhibit G Other Areas

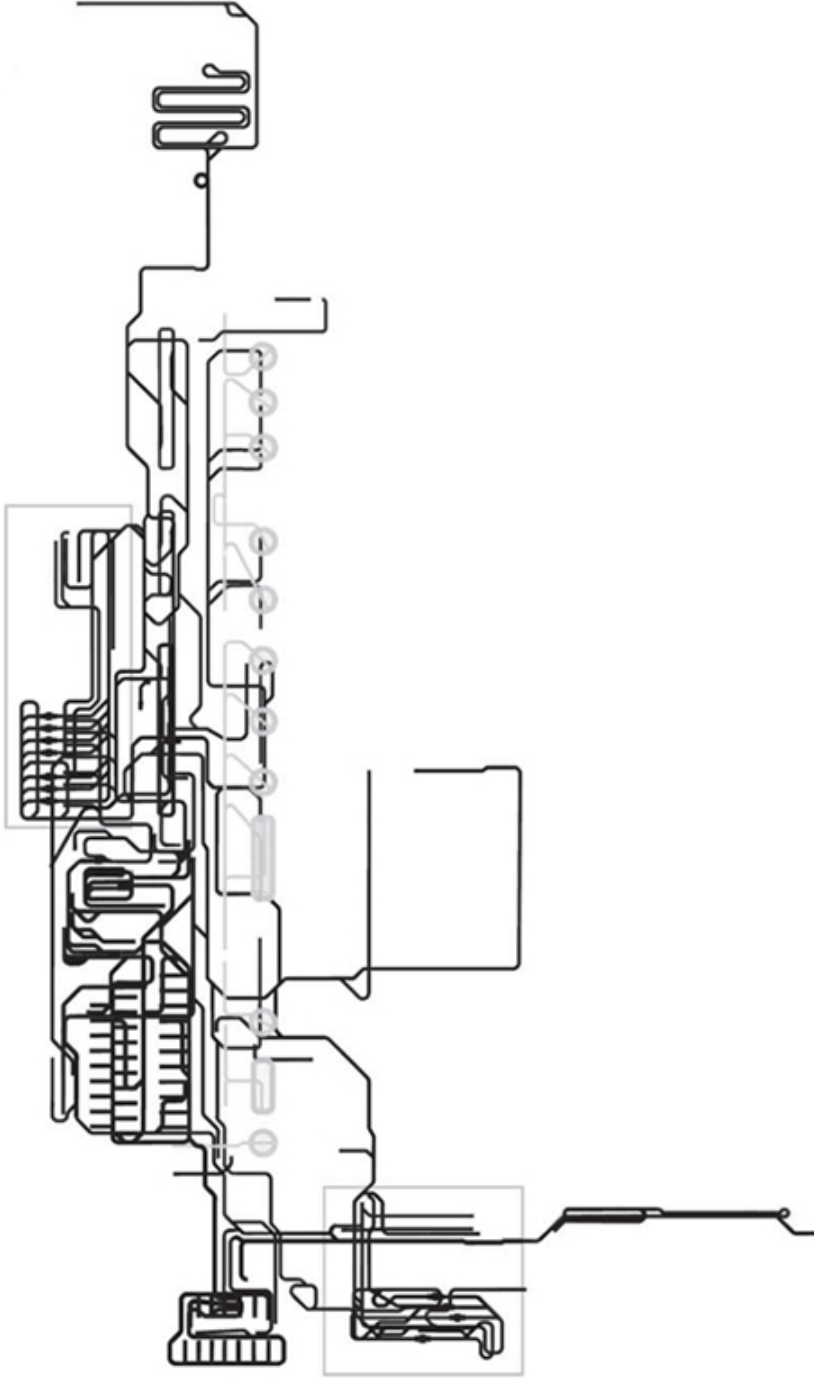

- NBOUND  
TOTAL LENGTH OF SYSTEM: 2,682' - 7"
- OUTBOUND  
TOTAL LENGTH OF SYSTEM: 31,270' - 11"
- TOTAL LENGTH OF CBS: 33,954' - 6"

**Leased Premises**

Not applicable.



Metropolitan Airports Commission  
Minneapolis-St. Paul International Airport  
Indirect Cost Center Allocations

Cost Center	Indirect Cost Centers				
	Maintenance Labor(%)	Equipment Building (%)	ARFF (%)	Police (%)	Administration (%) /1
Airfield	47.50	52.5	70.0	22.50	
Terminal One	17.25	1.5	20.0	18.00	
Terminal Apron	9.00	30.5			
Humphrey Terminal 2	4.00	1.0	2.5	5.00	
International Arrivals Facility	0.75		1.0	1.25	
Landside Area	11.50	8.0	2.5	30.25	
Other Areas	8.00	6.5	4.0	23.00	
Equipment Buildings	2.00				
<b>Total</b>	<b>100.0</b>	<b>100.0</b>	<b>100.0</b>	<b>100.0</b>	<b>100.0</b>

/1 The annual costs associated with Administration shall be allocated to each of the Airport Cost Centers according to the following calculation: (1) the ratio of (a) (i) the annual costs associated with a particular direct Airport Cost Center plus (ii) the annual amount allocated to such direct Airports Cost Center from the indirect Airport Cost Centers (other than Administration) to (b) the total annual cost of all Airport Cost Centers (other than Administration), times (2) the total annual costs for the Administration Airport Cost Center.

Example:

Terminal Building annual cost	\$ 10,000,000	
Indirect cost center allocations to Terminal Building:		
Maintenance labor	650,000	
Equipment buildings	50,000	
ARFF	200,000	
Police	1,000,000	
Subtotal	\$ 11,900,000	[A]
Total annual costs of all cost centers	\$ 80,000,000	[B]
Terminal Building share of total annual costs of all cost centers	14.9%	[C=A/B]
Administration annual costs	\$ 15,000,000	[D]
Terminal Building share of Administration annual costs	\$ 2,231,250	[C*D]

Metropolitan Airports Commission  
Minneapolis-St. Paul International Airport  
Indirect Cost Center Allocations

Cost Center	Indirect Cost Centers				
	Maintenance Labor(%)	Equipment Building (%)	ARFF (%)	Police (%)	Administration (%) /1
Airfield	50.0	55.0	70.0	25.0	
Terminal One	20.0	2.0	20.0	25.0	
Terminal Apron	10.0	25.0			
Humphrey Terminal 2	6.0	1.0	3.0	8.0	
International Arrivals Facility	1.0		1.0	1.5	
Landside Area	10.0	12.0	2.0	20.5	
Other Areas	3.0	5.0	4.0	20.0	
Equipment Buildings					
<b>Total</b>	<b>100.0</b>	<b>100.0</b>	<b>100.0</b>	<b>100.0</b>	<b>100.0</b>

/1 The annual costs associated with Administration shall be allocated to each of the Airport Cost Centers according to the following calculation: (1) the ratio of (a)(i) the annual costs associated with a particular direct Airport Cost Center plus (ii) the annual amount allocated to such direct Airports Cost Center from the indirect Airport Cost Centers (other than Administration) to (b) the total annual cost of all Airport Cost Centers (other than Administration), times (2) the total annual costs for the Administration Airport Cost Center.

Example:

Terminal Building annual cost	\$ 10,000,000	
Indirect cost center allocations to Terminal Building:		
Maintenance labor	650,000	
Equipment buildings	50,000	
ARFF	200,000	
Police	1,000,000	
Subtotal	\$ 11,900,000	[A]
Total annual costs of all cost centers	\$ 80,000,000	[B]
Terminal Building share of total annual costs of all cost centers	14.9%	[C=AIB]
Administration annual costs	\$ 15,000,000	[D]
Terminal Building share of Administration annual costs	\$ 2,231,250	[C*D]

Metropolitan Airports Commission  
 Minneapolis St Paul International Airport  
 Illustration of Calculation of Rates for Rents, Fees and Charges  
 Calculation of Landing Fees

Article Reference		201x
VI.C.1	Direct Operation and Maintenance Expense	\$ 16,233,184
	Direct Debt Service	7,295,269
	Maintenance Labor Allocation	10,657,735
	Equipment Building Allocation	4,432,320
	Fire Allocation	6,649,950
	Police Allocation	4,366,093
	Administration Allocation	6,725,738
	Fine, Assessment, Judgement, Settlement	0
	Debt Service Reserve Fund Deposit	0
	Operation Reserve Account Deposit	0
	Coverage Account Deposit	0
	Landing Fee Repair and Replacement Amount	14,988,467
	Cost of Runway 17/35 Deferral	79,535
	<b>Total Airfield Cost</b>	<b>\$ 71,428,291</b>
	<b>Less:</b>	
VI.C.2	Service Fees	\$ (232,275)
	General Aviation and Non-Signatory Landing Fees	(995,000)
	Debt Service on Capital Costs Disapproved by a Majority-In-Interest of Signatory Airlines	0
	<b>Total Adjustments</b>	<b>\$ (1,227,275)</b>
	<b>Net Airfield Cost</b>	<b>\$ 70,201,016</b>
VI.C.3	Total Landed Weight of Signatory Airlines (1,000-lbs Units)	23,186,000
	Landing Fee Rate per 1,000 lbs	\$ 3.03

Metropolitan Airports Commission  
 Minneapolis St Paul International Airport  
 Illustration of Calculation of Rates for Rents, Fees and Charges  
 Calculation of Terminal Apron Rates

<u>Article Reference</u>		<u>201x</u>
VI.D.1	Direct Operation and Maintenance Expense	\$ 273,645
	Direct Debt Service	10,931
	Maintenance Labor Allocation	2,019,360
	Equipment Building Allocation	2,574,967
	Administration Allocation	661,116
	Debt Service Reserve Fund Deposit	0
	Operation Reserve Account Deposit	0
	Coverage Account Deposit	0
	Ramp Fee Repair and Replacement Amount	868,234
	Concourse A and B Apron Deferral	159,950
	<b>Total Terminal Apron Cost</b>	<b>\$ 6,568,203</b>
VI.D2	Lineal Feet of Terminal Apron	11,001
	Terminal Apron Rate per Lineal Foot	<b>\$ 597.06</b>

Metropolitan Airports Commission  
 Minneapolis St Paul International Airport  
 Illustration of Calculation of Rates for Rents, Fees and Charges  
 Calculation of Terminal Building Rates, Fees and Charges (Janitored and Unjanitored Space)

Article Reference	201x
VI.E.1.a	
Direct Operation and Maintenance Expense	\$ 45,643,223
Direct Debt Service	25,806,918
Maintenance Labor Allocation	3,870,440
Equipment Building Allocation	126,638
Fire Allocation	1,899,986
Police Allocation	3,492,874
Administration Allocation	10,954,248
Debt Service Reserve Fund Deposit	0
Operation Reserve Account Deposit	0
Coverage Account Deposit	0
Cost of Concourse A, B, C and D Deferral	2,910,537
<b>Total Terminal Building Cost</b>	<b>\$ 94,704,864</b>
<b>Less:</b>	
VI.E.1.b	
IAF Maintenance and Operations Expense	\$ (1,854,994)
Ground Power	(974,701)
Loading Dock	(2,108,485)
Carrousel and Conveyors	0
Concession Utilities	(1,554,996)
Items in V1.K	(3,142,896)
Janitorial Operation and Maintenance Expense	(10,481,262)
<b>Total Adjustments</b>	<b>\$ (20,117,334)</b>
<b>Net Terminal Building Cost</b>	<b>\$ 74,587,530</b>
VI.E.1c	
Total Rentable Space	1,192,437
Terminal Building Rental Rate per square foot for Unjanitored Space	<b>\$ 62.55</b>
<b>Janitored Space Rate Calculation</b>	
VI.E.2	
Total Direct Janitored Operation and Maint. Exp.	\$ 10,481,262
Total Janitored Space /1	1,164,341
Janitored Rate per square Foot	\$ 9.00
Terminal Building Rental Rate per square foot for Unjanitored Space	<b>\$ 62.55</b>
Terminal Building Rental Rate per square foot for Janitored space	<b>\$ 71.55</b>

/1 Excludes MAC and Mechanical Space

Metropolitan Airports Commission  
 Minneapolis St Paul International Airport  
 Illustration of Calculation of Rates for Rents, Fees and Charges  
 Calculation of Cost per Enplaned Passenger

	<u>Budget 2019</u>
Landing Fees-Signatory	\$ 70,201,016
Landing Fees-T2 Non-Signatory	45,000
Landing Fees-Commuter Non-Signatory	150,000
Ramp Fees-Signatory	6,568,203
Ramp Fees-T2 Non-Signatory	200,000
Airline Repair and Replacement	4,814,528
Terminal 1 Building Rentals	39,645,504
IAF Fees	3,981,832
Queue Line, MUFIDS, PA System, EE Screening	2,235,544
Gate Fee for E1 and B15	429,000
Baggage Maintenance Fee (including Carrousel & Conveyors)	1,550,000
Porter Service Fee-T1	310,000
T2 Lobby Fees	10,992,739
T2 FIS Surcharge	1,885,009
T2 Building Rentals	955,119
Revenue Sharing	(16,181,148)
<b>Total Costs</b>	<b>\$ 127,782,346</b>
Enplaned Passengers	18,700,000
<b>Airline Cost per Enplaned Passenger</b>	<b>\$ 6.83</b>

**Metropolitan Airports Commission  
Minneapolis-St. Paul International Airport  
Table of Initial Rentable Square Footage**

The table of initial rentable square footage presented below includes the amount and breakdown of rentable square footage as of January 1, 2019, which amount may change from time to time.

Type of Space	Rentable Square Footage									Total
	Lindbergh Terminal	HUB Building	G Concourse	F Concourse	E Concourse	D Concourse	C Concourse	B Concourse	A Concourse	
Airline Space	52,260	1,509	32,720	47,585	26,071	17,314	97,722	2,163	10,542	287,886
Holdroom	—	—	34,572	34,324	26,564	12,238	49,674	10,488	11,317	179,177
Concession	101,756	946	35,049	20,828	12,984	9,070	26,605	3,571	5,877	216,686
Baggage Makeup	65,527	—	7,003	—	—	—	—	—	—	72,530
Tug Drive	44,105	—	—	—	—	—	—	—	—	44,105
Baggage Claim	38,476	—	—	—	—	—	—	—	—	38,476
Ticket Counter	8,736	—	—	—	—	—	—	—	—	8,736
Other*	259,409	23,228	532	3,584	17,145	3,447	32,787	2,531	2,178	344,841
<b>Total</b>	<b>570,269</b>	<b>25,683</b>	<b>109,876</b>	<b>106,321</b>	<b>82,764</b>	<b>42,069</b>	<b>206,788</b>	<b>18,753</b>	<b>29,914</b>	<b>1,192,437</b>

\* Other includes non-airline space, other/unoccupied space, holdroom stairs, airline toilets, miscellaneous space and garage.

Metropolitan Airports Commission  
 Minneapolis-St. Paul International Airport  
 Maintenance Responsibility Matrix

SPACE CATEGORY SPACE TYPE (Note 1)	TICKET (3) COUNTERS	AIRLINE (3) OFFICES	* HOLDROOMS	MEZZ OFFICES	OPERATIONS OFFICES
	E	E	P	E	E
<b>RESPONSIBILITY (Note 2)</b>					
<b><u>Interior Room</u></b>					
1. Custodial Service	T	O	M	O	O
2. Cleaning, painting, & repair of interior floor covering, walls, ceilings, windows, doors	M	T	M	T	T
3. Trash removal	T	T	M	T	T
4. Door locks & keys	M	M	M	M	M
5. Pest Extermination	M	M	M	M	M
6. Gate Hold Podium/Backwall/Airline Improvements	T	T	T	T	T
<b><u>Electrical &amp; Lighting</u></b>					
1. Relamping	M	T	M	T	T
2. Replace ballasts	M	T	M	T	T
3. Replace fixtures	M	T	M	T	T
4. Repair of outlets & fixtures	M	T	M	T	T
<b><u>HVAC</u></b>					
1. Maint. & repair of internal distribution system	M	M	M	M	M
2. Conditioned air	M	M	M	M	M
3. Outlets	M	T	M	T	T
<b><u>Plumbing &amp; Sewer System</u></b>					
1. Maintenance & Repair of internal distribution system	NA	T	NA	T	T
2. Maint. & Repair of fixtures and drains.	NA	T	NA	T	T
<b><u>Bag Make Up Devices</u></b>					
1. Maint & Repair of conveyors	T	NA	NA	NA	NA
2. Cleaning	T	NA	NA	NA	NA
<b><u>Bag Claim Devices</u></b>					
1. Maint. & Repair of carousels	M	NA	NA	NA	NA
2. Cleaning	M	NA	NA	NA	NA
<b><u>Elevators &amp; Escalators</u></b>					
1. Maint. & Repair	NA	NA	NA	NA	NA
2. Cleaning	NA	NA	NA	NA	NA

\* Please note VIII., Sec. A. #4a.



Metropolitan Airports Commission  
 Minneapolis-St. Paul International Airport  
 Maintenance Responsibility Matrix

**EXHIBIT P**  
 1/1/2019  
 Page 2 of 6

<b>SPACE CATEGORY</b>	<b>TICKET (3) COUNTERS</b>	<b>AIRLINE (3) OFFICES</b>	<b>* HOLDROOMS</b>	<b>MEZZ OFFICES</b>	<b>OPERATIONS OFFICES</b>
<b><u>Structural &amp; Exterior</u></b>					
<b>1. Roof</b>	M	M	M	M	M
<b>2. Exterior Walls</b>	M	M	M	M	M
<b>3. Foundation</b>	M	M	NA	NA	M
<b>4. Floors</b>	M	T	T	T	T
<b>5. Windows</b>	NA	T	M	M	M
<b>6. Public access Doors</b>	NA	T	M	T	T
<b>7. Bag cart o/h Doors</b>	NA	NA	NA	NA	NA
<b>8. Sidewalks</b>	NA	NA	NA	NA	NA

**NOTES:**

**#1 Key to Space Type**

- E= Exclusive Space
- C = Common Use Space
- M= MAC Space
- P = Public Space

**#2 Key to Responsibility**

- T- Tenant ( Airline or Concessionaire or Other)
- M- MAC
- O- Optional
- N/A- Not Applicable

**#3.Space Type in Auto Rental Building treated the same excel.maintmatrix**

\* Please note VIII., Sec. A. #4a.

Metropolitan Airports Commission  
 Minneapolis-St. Paul International Airport  
 Maintenance Responsibility Matrix

SPACE CATEGORY SPACE TYPE (Note 1) RESPONSIBILITY (Note 2)	<u>OPERATIONS AREAS</u>	<u>BAG MAKE UP</u>	<u>BAG CLAIM</u>	<u>CONCESSION</u>	<u>CIRCULATION (3)</u>
	E	E	C	E	P
<b><u>Interior Room</u></b>					
1. Custodial Service	T	T	M	T	M
2. Cleaning, painting, & repair of interior floor covering, walls, ceilings, windows, doors	T	T	M	T	M
3. Trash removal	T	T	M	T	M
4. Door locks & keys	M	M	M	T	M
5. Pest Extermination	M	M	M	T	M
6. Gate Hold Podium/Backwall/Airline Improvements	T	T	T	T	T
<b><u>Electrical &amp; Lighting</u></b>					
1. Relamping	T	T	M	T	M
2. Replace ballasts	T	T	M	T	M
3. Replace fixtures	T	T	M	T	M
4. Repair of outlets & fixtures	T	T	M	T	M
<b><u>HVAC</u></b>					
1. Maint. & repair of internal distribution system	M	M	M	M	M
2. Conditioned air	M	M	M	M	M
3. Outlets	T	M	M	T	M
<b><u>Plumbing &amp; Sewer System</u></b>					
1. Maintenance & Repair of internal distribution system	T	T	M	T	M
2. Maint. & Repair of fixtures and drains.	T	T	M	T	M
<b><u>Bag Make Up Devices</u></b>					
1. Maint & Repair of conveyors	NA	T	NA	NA	NA
2. Cleaning	NA	T	NA	NA	NA
<b><u>Bag Claim Devices</u></b>					
1. Maint. & Repair of carousels	NA	NA	M	NA	NA
2. Cleaning	NA	NA	M	NA	NA
<b><u>Elevators &amp; Escalators</u></b>					
1. Maint. & Repair	NA	NA	M	NA	M
2. Cleaning	NA	NA	M	NA	M

\* Please note VIII., Sec. A. #4a.

<b>SPACE CATEGORY</b>	<b>OPERATIONS AREAS</b>	<b>BAG MAKE UP</b>	<b>BAG CLAIM</b>	<b>CONCESSION</b>	<b>CIRCULATION (3)</b>
<b>Structural &amp; Exterior</b>					
<b>1. Roof</b>	M	M	NA	M	M
<b>2. Exterior Walls</b>	M	M	M	M	M
<b>3. Foundation</b>	M	M	M	M	M
<b>4. Floors</b>	T	T	M	T	M
<b>5. Windows</b>	T & M	T	M	T & M	M
<b>6. Public access Doors</b>	NA	NA	M	T	M
<b>7. Bag cart o/h Doors</b>	T	M	M	NA	NA
<b>8. Sidewalks</b>	NA	NA	M	NA	M

**NOTES:**

**#1 Key to Space Type**

- E= Exclusive Space
- C = Common Use Space
- M= MAC Space
- P = Public Space

**#2 Key to Responsibility**

- T- Tenant ( Airline or Concessionaire or Other)
- M- MAC
- O- Optional
- N/A- Not Applicable

**#3.Space Type in Auto Rental**

Building treated the same excel.maintmatrix

\* Please note VIII., Sec. A. #4a.

Metropolitan Airports Commission  
 Minneapolis-St. Paul International Airport  
 Maintenance Responsibility Matrix

**EXHIBIT P**  
 1/1/2019  
 Page 5 of 6

SPACE CATEGORY SPACE TYPE (Note 1)	<u>REST (3) ROOMS</u> P	<u>MECH. (3) ROOMS</u> M	<u>MAC OFFICES</u> M	<u>TERMINAL RAMP</u> P	<u>TUG DRIVE</u> C
<b>RESPONSIBILITY (Note 2)</b>					
<b><u>Interior Room</u></b>					
1. Custodial Service	M	M	M	NA	M
2. Cleaning, painting, & repair of interior floor covering, walls, ceilings, windows, doors	M	M	M	NA	M
3. Trash removal	M	M	M	T	M
4. Door locks & keys	M	M	M	NA	M
5. Pest Extermination	M	M	M	M	M
6. Gate Hold Podium/Backwall/Airline Improvements	T	NA	NA	T	T
<b><u>Electrical &amp; Lighting</u></b>					
1. Relamping	M	M	M	M	M
2. Replace ballasts	M	M	M	M	M
3. Replace fixtures	M	M	M	M	M
4. Repair of outlets & fixtures	M	M	M	M	M
<b><u>HVAC</u></b>					
1. Maint. & repair of internal distribution system	M	M	M	NA	M
2. Conditioned air	M	M	M	NA	M
3. Outlets	M	M	M	NA	M
<b><u>Plumbing &amp; Sewer System</u></b>					
1. Maintenance & Repair of internal distribution system	M	M	M	NA	M
2. Maint. & Repair of fixtures and drains.	M	M	M	NA	M
<b><u>Bag Make Up Devices</u></b>					
1. Maint & Repair of conveyors	NA	NA	NA	NA	T
2. Cleaning	NA	NA	NA	NA	T
<b><u>Bag Claim Devices</u></b>					
1. Maint. & Repair of carousels	NA	NA	NA	NA	NA
2. Cleaning	NA	NA	NA	NA	NA
<b><u>Elevators &amp; Escalators</u></b>					
1. Maint. & Repair	NA	NA	NA	NA	NA
2. Cleaning	NA	NA	NA	NA	NA

\* Please note VIII., Sec. A. #4a.

Metropolitan Airports Commission  
 Minneapolis-St. Paul International Airport  
 Maintenance Responsibility Matrix

<b>SPACE CATEGORY</b>	<b><u>REST (3)</u></b> <b><u>ROOMS</u></b>	<b><u>MECH (3)</u></b> <b><u>ROOMS</u></b>	<b><u>MAC</u></b> <b><u>OFFICES</u></b>	<b><u>TERMINAL</u></b> <b><u>RAMP</u></b>	<b><u>TUG</u></b> <b><u>DRIVE</u></b>
<b><u>Structural &amp; Exterior</u></b>					
<b>1. Roof</b>	M	M	M	NA	M
<b>2. Exterior Walls</b>	M	M	M	NA	M
<b>3. Foundation</b>	M	M	M	NA	M
<b>4. Floors</b>	M	M	M	NA	M
<b>5. Windows</b>	NA	NA	M	NA	NA
<b>6. Public access Doors</b>	NA	NA	M	NA	NA
<b>7. Bag cart o/h Doors</b>	NA	NA	NA	NA	NA
<b>8. Sidewalks</b>	NA	NA	M	NA	NA

**NOTES:**

**#1 Key to Space Type**

- E= Exclusive Space
- C = Common Use Space
- M= MAC Space
- P = Public Space

**#2 Key to Responsibility**

- T- Tenant ( Airline or Concessionaire or Other)
- M- MAC
- O- Optional
- N/A- Not Applicable

**#3. Space Type in Auto Rental**

Building treated the same excel.maintmatrix

\* Please note VIII., Sec. A. #4a.

**Month-To-Month Premises**

The following premise will be leased on a month-to-month basis:

- Airline e-ticket machines, kiosks and cash-to-card machines
- EAS airline space
- Temporary use as a result of construction or other building alternation
- Temporary use for operational necessity

Month-to-month premises will be marked MTM on Exhibit J.

Exhibit T Month-To-Month Premises

**Short Term Gate Summary**

The following is a summary of Terminal 1-Lindbergh Short Term Gates:

- D1 (potential substitute B16)
- D2
- D3
- D4
- D5 (potential substitute B14)
- D6
- E2
- E3
- E6
- E11

Exhibit V Short Term Gate Summary

**EXHIBIT V**

Date : JANUARY 1, 2019  
 Page 1 of 3

**LEGEND**

	TERMINAL BUILDING LEASED AREA
	SHARED AREA
	MTM LEASED AREA
	SHORT TERM LEASE AREA



Metropolitan Airports Commission  
 6040 29th Avenue So.  
 Minneapolis, MN 55416

**Space Category Key**

INT	INTERIOR
EXT	EXTERIOR
ST	STAIR
TR	TRAVEL
PL	PUBLIC LOBBY
1A	1A PUBLIC LOBBY
1B	1B PUBLIC LOBBY
1C	1C PUBLIC LOBBY
1D	1D PUBLIC LOBBY
1E	1E PUBLIC LOBBY
1F	1F PUBLIC LOBBY
1G	1G PUBLIC LOBBY
1H	1H PUBLIC LOBBY
1I	1I PUBLIC LOBBY
1J	1J PUBLIC LOBBY
1K	1K PUBLIC LOBBY
1L	1L PUBLIC LOBBY
1M	1M PUBLIC LOBBY
1N	1N PUBLIC LOBBY
1O	1O PUBLIC LOBBY
1P	1P PUBLIC LOBBY
1Q	1Q PUBLIC LOBBY
1R	1R PUBLIC LOBBY
1S	1S PUBLIC LOBBY
1T	1T PUBLIC LOBBY
1U	1U PUBLIC LOBBY
1V	1V PUBLIC LOBBY
1W	1W PUBLIC LOBBY
1X	1X PUBLIC LOBBY
1Y	1Y PUBLIC LOBBY
1Z	1Z PUBLIC LOBBY
2A	2A PUBLIC LOBBY
2B	2B PUBLIC LOBBY
2C	2C PUBLIC LOBBY
2D	2D PUBLIC LOBBY
2E	2E PUBLIC LOBBY
2F	2F PUBLIC LOBBY
2G	2G PUBLIC LOBBY
2H	2H PUBLIC LOBBY
2I	2I PUBLIC LOBBY
2J	2J PUBLIC LOBBY
2K	2K PUBLIC LOBBY
2L	2L PUBLIC LOBBY
2M	2M PUBLIC LOBBY
2N	2N PUBLIC LOBBY
2O	2O PUBLIC LOBBY
2P	2P PUBLIC LOBBY
2Q	2Q PUBLIC LOBBY
2R	2R PUBLIC LOBBY
2S	2S PUBLIC LOBBY
2T	2T PUBLIC LOBBY
2U	2U PUBLIC LOBBY
2V	2V PUBLIC LOBBY
2W	2W PUBLIC LOBBY
2X	2X PUBLIC LOBBY
2Y	2Y PUBLIC LOBBY
2Z	2Z PUBLIC LOBBY
3A	3A PUBLIC LOBBY
3B	3B PUBLIC LOBBY
3C	3C PUBLIC LOBBY
3D	3D PUBLIC LOBBY
3E	3E PUBLIC LOBBY
3F	3F PUBLIC LOBBY
3G	3G PUBLIC LOBBY
3H	3H PUBLIC LOBBY
3I	3I PUBLIC LOBBY
3J	3J PUBLIC LOBBY
3K	3K PUBLIC LOBBY
3L	3L PUBLIC LOBBY
3M	3M PUBLIC LOBBY
3N	3N PUBLIC LOBBY
3O	3O PUBLIC LOBBY
3P	3P PUBLIC LOBBY
3Q	3Q PUBLIC LOBBY
3R	3R PUBLIC LOBBY
3S	3S PUBLIC LOBBY
3T	3T PUBLIC LOBBY
3U	3U PUBLIC LOBBY
3V	3V PUBLIC LOBBY
3W	3W PUBLIC LOBBY
3X	3X PUBLIC LOBBY
3Y	3Y PUBLIC LOBBY
3Z	3Z PUBLIC LOBBY
4A	4A PUBLIC LOBBY
4B	4B PUBLIC LOBBY
4C	4C PUBLIC LOBBY
4D	4D PUBLIC LOBBY
4E	4E PUBLIC LOBBY
4F	4F PUBLIC LOBBY
4G	4G PUBLIC LOBBY
4H	4H PUBLIC LOBBY
4I	4I PUBLIC LOBBY
4J	4J PUBLIC LOBBY
4K	4K PUBLIC LOBBY
4L	4L PUBLIC LOBBY
4M	4M PUBLIC LOBBY
4N	4N PUBLIC LOBBY
4O	4O PUBLIC LOBBY
4P	4P PUBLIC LOBBY
4Q	4Q PUBLIC LOBBY
4R	4R PUBLIC LOBBY
4S	4S PUBLIC LOBBY
4T	4T PUBLIC LOBBY
4U	4U PUBLIC LOBBY
4V	4V PUBLIC LOBBY
4W	4W PUBLIC LOBBY
4X	4X PUBLIC LOBBY
4Y	4Y PUBLIC LOBBY
4Z	4Z PUBLIC LOBBY
5A	5A PUBLIC LOBBY
5B	5B PUBLIC LOBBY
5C	5C PUBLIC LOBBY
5D	5D PUBLIC LOBBY
5E	5E PUBLIC LOBBY
5F	5F PUBLIC LOBBY
5G	5G PUBLIC LOBBY
5H	5H PUBLIC LOBBY
5I	5I PUBLIC LOBBY
5J	5J PUBLIC LOBBY
5K	5K PUBLIC LOBBY
5L	5L PUBLIC LOBBY
5M	5M PUBLIC LOBBY
5N	5N PUBLIC LOBBY
5O	5O PUBLIC LOBBY
5P	5P PUBLIC LOBBY
5Q	5Q PUBLIC LOBBY
5R	5R PUBLIC LOBBY
5S	5S PUBLIC LOBBY
5T	5T PUBLIC LOBBY
5U	5U PUBLIC LOBBY
5V	5V PUBLIC LOBBY
5W	5W PUBLIC LOBBY
5X	5X PUBLIC LOBBY
5Y	5Y PUBLIC LOBBY
5Z	5Z PUBLIC LOBBY
6A	6A PUBLIC LOBBY
6B	6B PUBLIC LOBBY
6C	6C PUBLIC LOBBY
6D	6D PUBLIC LOBBY
6E	6E PUBLIC LOBBY
6F	6F PUBLIC LOBBY
6G	6G PUBLIC LOBBY
6H	6H PUBLIC LOBBY
6I	6I PUBLIC LOBBY
6J	6J PUBLIC LOBBY
6K	6K PUBLIC LOBBY
6L	6L PUBLIC LOBBY
6M	6M PUBLIC LOBBY
6N	6N PUBLIC LOBBY
6O	6O PUBLIC LOBBY
6P	6P PUBLIC LOBBY
6Q	6Q PUBLIC LOBBY
6R	6R PUBLIC LOBBY
6S	6S PUBLIC LOBBY
6T	6T PUBLIC LOBBY
6U	6U PUBLIC LOBBY
6V	6V PUBLIC LOBBY
6W	6W PUBLIC LOBBY
6X	6X PUBLIC LOBBY
6Y	6Y PUBLIC LOBBY
6Z	6Z PUBLIC LOBBY
7A	7A PUBLIC LOBBY
7B	7B PUBLIC LOBBY
7C	7C PUBLIC LOBBY
7D	7D PUBLIC LOBBY
7E	7E PUBLIC LOBBY
7F	7F PUBLIC LOBBY
7G	7G PUBLIC LOBBY
7H	7H PUBLIC LOBBY
7I	7I PUBLIC LOBBY
7J	7J PUBLIC LOBBY
7K	7K PUBLIC LOBBY
7L	7L PUBLIC LOBBY
7M	7M PUBLIC LOBBY
7N	7N PUBLIC LOBBY
7O	7O PUBLIC LOBBY
7P	7P PUBLIC LOBBY
7Q	7Q PUBLIC LOBBY
7R	7R PUBLIC LOBBY
7S	7S PUBLIC LOBBY
7T	7T PUBLIC LOBBY
7U	7U PUBLIC LOBBY
7V	7V PUBLIC LOBBY
7W	7W PUBLIC LOBBY
7X	7X PUBLIC LOBBY
7Y	7Y PUBLIC LOBBY
7Z	7Z PUBLIC LOBBY
8A	8A PUBLIC LOBBY
8B	8B PUBLIC LOBBY
8C	8C PUBLIC LOBBY
8D	8D PUBLIC LOBBY
8E	8E PUBLIC LOBBY
8F	8F PUBLIC LOBBY
8G	8G PUBLIC LOBBY
8H	8H PUBLIC LOBBY
8I	8I PUBLIC LOBBY
8J	8J PUBLIC LOBBY
8K	8K PUBLIC LOBBY
8L	8L PUBLIC LOBBY
8M	8M PUBLIC LOBBY
8N	8N PUBLIC LOBBY
8O	8O PUBLIC LOBBY
8P	8P PUBLIC LOBBY
8Q	8Q PUBLIC LOBBY
8R	8R PUBLIC LOBBY
8S	8S PUBLIC LOBBY
8T	8T PUBLIC LOBBY
8U	8U PUBLIC LOBBY
8V	8V PUBLIC LOBBY
8W	8W PUBLIC LOBBY
8X	8X PUBLIC LOBBY
8Y	8Y PUBLIC LOBBY
8Z	8Z PUBLIC LOBBY
9A	9A PUBLIC LOBBY
9B	9B PUBLIC LOBBY
9C	9C PUBLIC LOBBY
9D	9D PUBLIC LOBBY
9E	9E PUBLIC LOBBY
9F	9F PUBLIC LOBBY
9G	9G PUBLIC LOBBY
9H	9H PUBLIC LOBBY
9I	9I PUBLIC LOBBY
9J	9J PUBLIC LOBBY
9K	9K PUBLIC LOBBY
9L	9L PUBLIC LOBBY
9M	9M PUBLIC LOBBY
9N	9N PUBLIC LOBBY
9O	9O PUBLIC LOBBY
9P	9P PUBLIC LOBBY
9Q	9Q PUBLIC LOBBY
9R	9R PUBLIC LOBBY
9S	9S PUBLIC LOBBY
9T	9T PUBLIC LOBBY
9U	9U PUBLIC LOBBY
9V	9V PUBLIC LOBBY
9W	9W PUBLIC LOBBY
9X	9X PUBLIC LOBBY
9Y	9Y PUBLIC LOBBY
9Z	9Z PUBLIC LOBBY

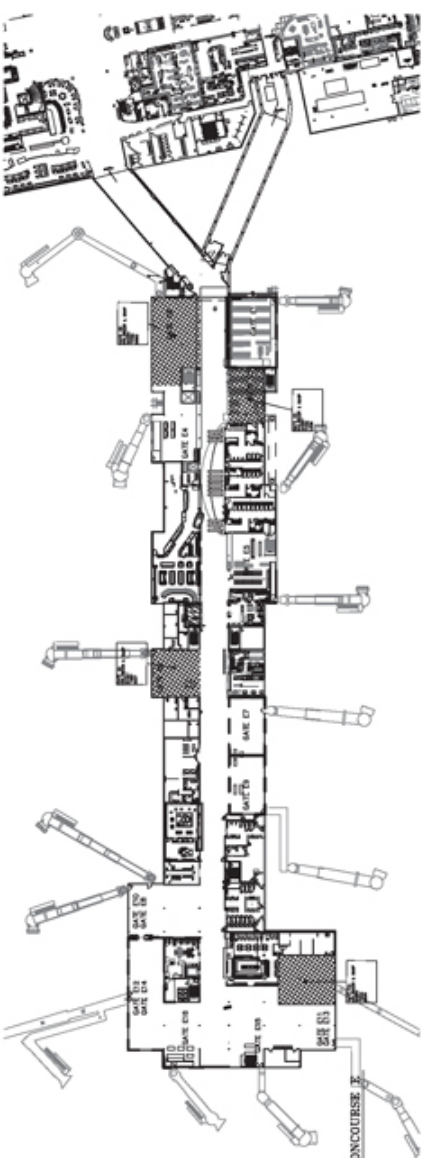

1 MAIN LEVEL PLAN: CONCOURSE E

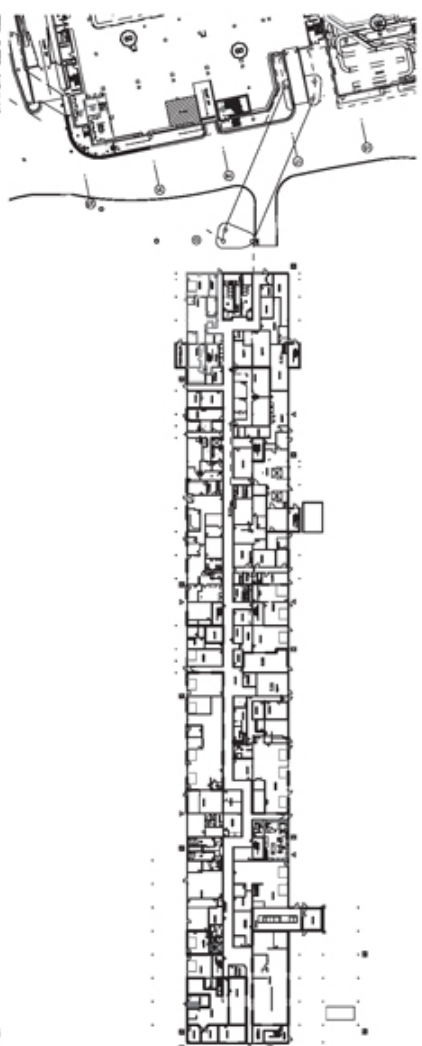

2 GROUND LEVEL PLAN: CONCOURSE E

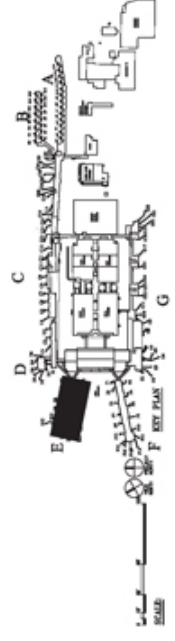



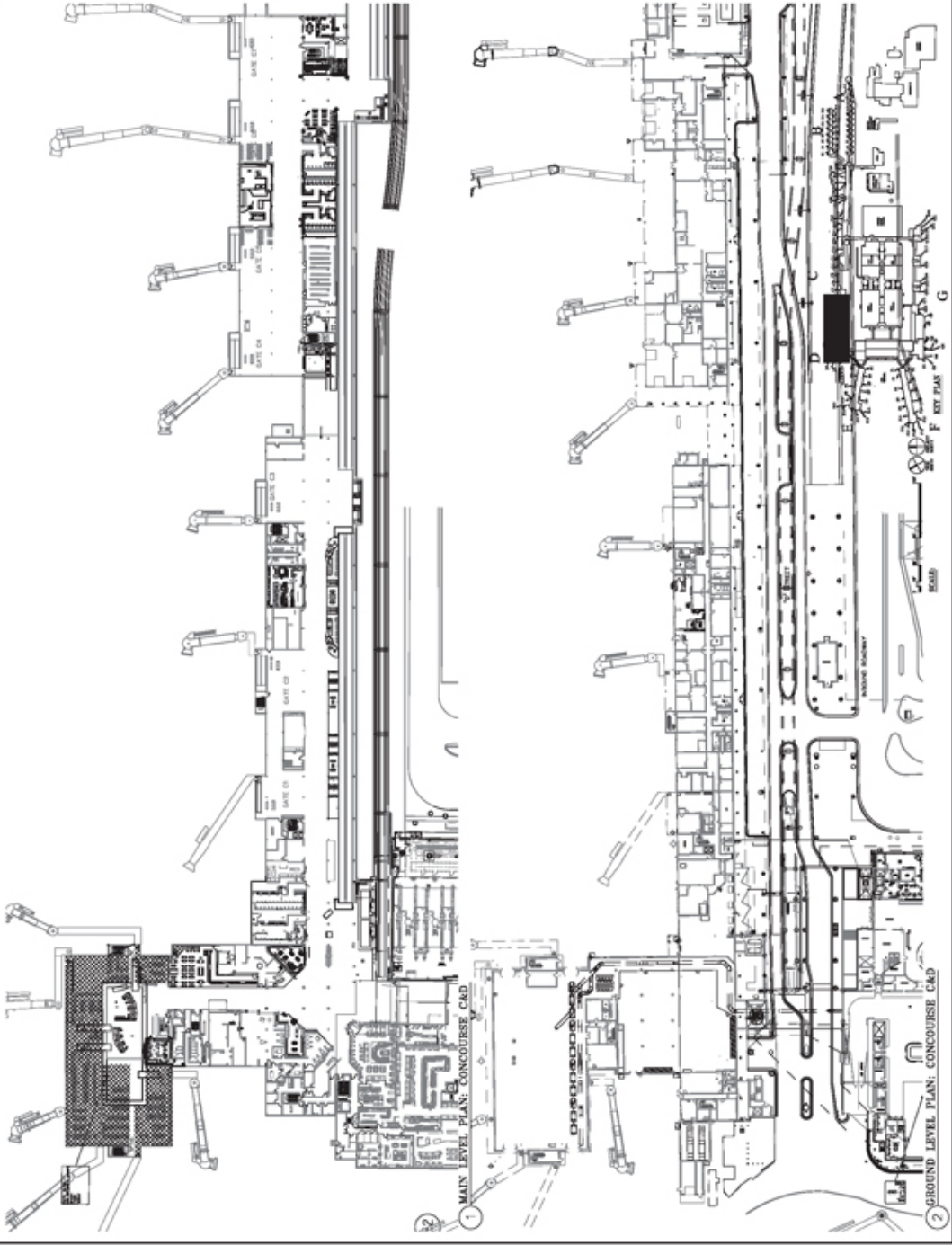

**EXHIBIT V**

Date : JANUARY 1, 2019  
 Page 2 of 3

**LEGEND**

TERMINAL BUILDING  
 LEASED AREA  
 SHARED AREA  
 MTM LEASED AREA  
 SHORT TERM LEASE AREA

**Metropolitan Airports Commission**  
 6040 29th Avenue So.  
 Minneapolis, MN 55410

**Space Category Key**

1. PUBLIC CONCOURSE  
 2. PUBLIC CONCOURSE  
 3. PUBLIC CONCOURSE  
 4. PUBLIC CONCOURSE  
 5. PUBLIC CONCOURSE  
 6. PUBLIC CONCOURSE  
 7. PUBLIC CONCOURSE  
 8. PUBLIC CONCOURSE  
 9. PUBLIC CONCOURSE  
 10. PUBLIC CONCOURSE  
 11. PUBLIC CONCOURSE  
 12. PUBLIC CONCOURSE  
 13. PUBLIC CONCOURSE  
 14. PUBLIC CONCOURSE  
 15. PUBLIC CONCOURSE  
 16. PUBLIC CONCOURSE  
 17. PUBLIC CONCOURSE  
 18. PUBLIC CONCOURSE  
 19. PUBLIC CONCOURSE  
 20. PUBLIC CONCOURSE  
 21. PUBLIC CONCOURSE  
 22. PUBLIC CONCOURSE  
 23. PUBLIC CONCOURSE  
 24. PUBLIC CONCOURSE  
 25. PUBLIC CONCOURSE  
 26. PUBLIC CONCOURSE  
 27. PUBLIC CONCOURSE  
 28. PUBLIC CONCOURSE  
 29. PUBLIC CONCOURSE  
 30. PUBLIC CONCOURSE  
 31. PUBLIC CONCOURSE  
 32. PUBLIC CONCOURSE  
 33. PUBLIC CONCOURSE  
 34. PUBLIC CONCOURSE  
 35. PUBLIC CONCOURSE  
 36. PUBLIC CONCOURSE  
 37. PUBLIC CONCOURSE  
 38. PUBLIC CONCOURSE  
 39. PUBLIC CONCOURSE  
 40. PUBLIC CONCOURSE  
 41. PUBLIC CONCOURSE  
 42. PUBLIC CONCOURSE  
 43. PUBLIC CONCOURSE  
 44. PUBLIC CONCOURSE  
 45. PUBLIC CONCOURSE  
 46. PUBLIC CONCOURSE  
 47. PUBLIC CONCOURSE  
 48. PUBLIC CONCOURSE  
 49. PUBLIC CONCOURSE  
 50. PUBLIC CONCOURSE  
 51. PUBLIC CONCOURSE  
 52. PUBLIC CONCOURSE  
 53. PUBLIC CONCOURSE  
 54. PUBLIC CONCOURSE  
 55. PUBLIC CONCOURSE  
 56. PUBLIC CONCOURSE  
 57. PUBLIC CONCOURSE  
 58. PUBLIC CONCOURSE  
 59. PUBLIC CONCOURSE  
 60. PUBLIC CONCOURSE  
 61. PUBLIC CONCOURSE  
 62. PUBLIC CONCOURSE  
 63. PUBLIC CONCOURSE  
 64. PUBLIC CONCOURSE  
 65. PUBLIC CONCOURSE  
 66. PUBLIC CONCOURSE  
 67. PUBLIC CONCOURSE  
 68. PUBLIC CONCOURSE  
 69. PUBLIC CONCOURSE  
 70. PUBLIC CONCOURSE  
 71. PUBLIC CONCOURSE  
 72. PUBLIC CONCOURSE  
 73. PUBLIC CONCOURSE  
 74. PUBLIC CONCOURSE  
 75. PUBLIC CONCOURSE  
 76. PUBLIC CONCOURSE  
 77. PUBLIC CONCOURSE  
 78. PUBLIC CONCOURSE  
 79. PUBLIC CONCOURSE  
 80. PUBLIC CONCOURSE  
 81. PUBLIC CONCOURSE  
 82. PUBLIC CONCOURSE  
 83. PUBLIC CONCOURSE  
 84. PUBLIC CONCOURSE  
 85. PUBLIC CONCOURSE  
 86. PUBLIC CONCOURSE  
 87. PUBLIC CONCOURSE  
 88. PUBLIC CONCOURSE  
 89. PUBLIC CONCOURSE  
 90. PUBLIC CONCOURSE  
 91. PUBLIC CONCOURSE  
 92. PUBLIC CONCOURSE  
 93. PUBLIC CONCOURSE  
 94. PUBLIC CONCOURSE  
 95. PUBLIC CONCOURSE  
 96. PUBLIC CONCOURSE  
 97. PUBLIC CONCOURSE  
 98. PUBLIC CONCOURSE  
 99. PUBLIC CONCOURSE  
 100. PUBLIC CONCOURSE

MINNEAPOLIS / ST. PAUL INTERNATIONAL AIRPORT  
 TERMINAL BUILDING  
 CONCOURSE C & D

FW115

# EXHIBIT V

Date : JANUARY 1, 2019  
 Page 3 of 3

- LEGEND**
- TERMINAL BUILDING LEASED AREA
  - SHARED AREA
  - MTM LEASED AREA
  - SHORT TERM LEASE AREA



Metropolitan  
 Airports  
 Commission  
 6040 29th Avenue So.  
 Minneapolis, MN 55416



- Space Category Key**
- 1A PUBLIC CONCOURSE
  - 1B PUBLIC CONCOURSE
  - 1C PUBLIC CONCOURSE
  - 1D PUBLIC CONCOURSE
  - 1E PUBLIC CONCOURSE
  - 1F PUBLIC CONCOURSE
  - 1G PUBLIC CONCOURSE
  - 1H PUBLIC CONCOURSE
  - 1I PUBLIC CONCOURSE
  - 1J PUBLIC CONCOURSE
  - 1K PUBLIC CONCOURSE
  - 1L PUBLIC CONCOURSE
  - 1M PUBLIC CONCOURSE
  - 1N PUBLIC CONCOURSE
  - 1O PUBLIC CONCOURSE
  - 1P PUBLIC CONCOURSE
  - 1Q PUBLIC CONCOURSE
  - 1R PUBLIC CONCOURSE
  - 1S PUBLIC CONCOURSE
  - 1T PUBLIC CONCOURSE
  - 1U PUBLIC CONCOURSE
  - 1V PUBLIC CONCOURSE
  - 1W PUBLIC CONCOURSE
  - 1X PUBLIC CONCOURSE
  - 1Y PUBLIC CONCOURSE
  - 1Z PUBLIC CONCOURSE
  - 2A PUBLIC CONCOURSE
  - 2B PUBLIC CONCOURSE
  - 2C PUBLIC CONCOURSE
  - 2D PUBLIC CONCOURSE
  - 2E PUBLIC CONCOURSE
  - 2F PUBLIC CONCOURSE
  - 2G PUBLIC CONCOURSE
  - 2H PUBLIC CONCOURSE
  - 2I PUBLIC CONCOURSE
  - 2J PUBLIC CONCOURSE
  - 2K PUBLIC CONCOURSE
  - 2L PUBLIC CONCOURSE
  - 2M PUBLIC CONCOURSE
  - 2N PUBLIC CONCOURSE
  - 2O PUBLIC CONCOURSE
  - 2P PUBLIC CONCOURSE
  - 2Q PUBLIC CONCOURSE
  - 2R PUBLIC CONCOURSE
  - 2S PUBLIC CONCOURSE
  - 2T PUBLIC CONCOURSE
  - 2U PUBLIC CONCOURSE
  - 2V PUBLIC CONCOURSE
  - 2W PUBLIC CONCOURSE
  - 2X PUBLIC CONCOURSE
  - 2Y PUBLIC CONCOURSE
  - 2Z PUBLIC CONCOURSE
  - 3A PUBLIC CONCOURSE
  - 3B PUBLIC CONCOURSE
  - 3C PUBLIC CONCOURSE
  - 3D PUBLIC CONCOURSE
  - 3E PUBLIC CONCOURSE
  - 3F PUBLIC CONCOURSE
  - 3G PUBLIC CONCOURSE
  - 3H PUBLIC CONCOURSE
  - 3I PUBLIC CONCOURSE
  - 3J PUBLIC CONCOURSE
  - 3K PUBLIC CONCOURSE
  - 3L PUBLIC CONCOURSE
  - 3M PUBLIC CONCOURSE
  - 3N PUBLIC CONCOURSE
  - 3O PUBLIC CONCOURSE
  - 3P PUBLIC CONCOURSE
  - 3Q PUBLIC CONCOURSE
  - 3R PUBLIC CONCOURSE
  - 3S PUBLIC CONCOURSE
  - 3T PUBLIC CONCOURSE
  - 3U PUBLIC CONCOURSE
  - 3V PUBLIC CONCOURSE
  - 3W PUBLIC CONCOURSE
  - 3X PUBLIC CONCOURSE
  - 3Y PUBLIC CONCOURSE
  - 3Z PUBLIC CONCOURSE

MINNEAPOLIS / ST. PAUL  
 INTERNATIONAL AIRPORT  
**TERMINAL BUILDING**  
 CONTOUR B

FM125

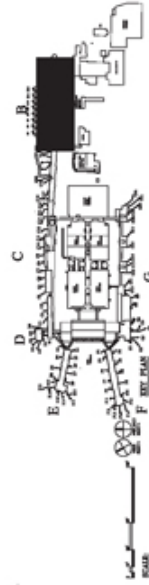
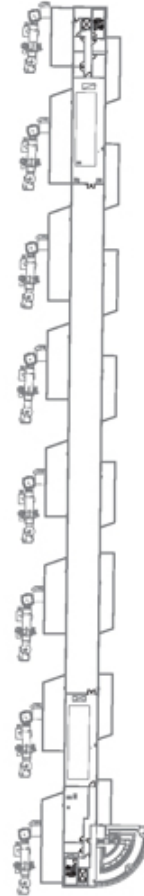
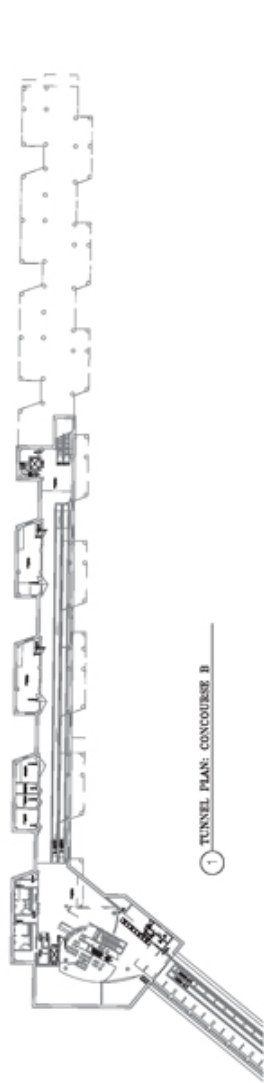

**Memorandum of Understanding  
For Ground Handling on Terminal 1 FIS Gates**

This Memorandum of Understanding (“MOU”) is made the \_\_\_\_\_ day of \_\_\_\_\_, 20XX, between the Metropolitan Airports Commission, a public corporation of the State of Minnesota (“MAC”), (insert airline name) authorized to do business in the State of Minnesota (“AIRLINE”), and Delta Air Lines, Inc., a Delaware corporation authorized to do business in the State of Minnesota (“Delta”).

WHEREAS, the parties to this MOU desire to establish the terms and conditions by which AIRLINE permitted to contract with a 3rd party for the provision of ground handling services while operating from Terminal 1 of the Minneapolis-St. Paul International Airport (“Airport”).

NOW, THEREFORE, in consideration of the foregoing and mutual promises and covenants set forth, the parties hereby agree as follows:

**1. Background Information**

AIRLINE has requested from MAC the ability to contract with a 3rd party ground handling company (“Ground Handling Company”) for the provision of below-wing ground handling services for its international operations which occur on Gates G1-G10 of Terminal 1 (the “Gates”).

**1. Airline Operating Agreement & Terminal Building Lease**

Pursuant to the Airline Operating Agreement and Terminal Building Lease (“Airline Agreement”) that both AIRLINE and Delta have separately entered into with the MAC, Airlines operating on the Gates have the option to either self-handle or utilize Delta for below-wing ground handling services. However, MAC, AIRLINE, and Delta would like to establish alternate terms and conditions by which AIRLINE is permitted to contract with a Ground Handling Company for the provision of below-wing ground handling services at the Gates without amending the Airline Agreement.

**3. Effective Date & Term**

The effective date of this MOU shall be \_\_\_\_\_.

This MOU is terminable by any party providing 90 days advance written notice to the other two parties in accordance with this MOU.

**4. MAC Commitments**

- A. Ensure the Ground Handling Company selected by AIRLINE executes and adheres to all of the requirements of MAC’s Limited Commercial Services License. This License establishes the insurance, indemnification, environmental, and financial requirements for operating at the Airport consistent with AIP grant assurances.
- B. Assist AIRLINE and Delta with ensuring the Ground Handling Company operates within the parameters established by this MOU and the Limited Commercial Services License.
- C. Assist with ensuring AIRLINE is provided access to FIS accessible gates in accordance with the Airline Agreement.
- D. In the event an aircraft is not able to depart the gate within the two hour limit for narrow-body aircraft and the three hour limit for wide-body aircraft identified in Section 5.D. and Delta is requiring use of the gate, MAC shall to the best of its ability assist AIRLINE in relocation of the aircraft to either another gate location designated by Delta or to a remote parking area designated by MAC or MAC’s agent.
- E. Establish ticket counters for AIRLINE and the Ground Handling Company independent of ticket counters occupied by Delta.

**5. AIRLINE Commitments**

- A. Provide in advance Delta and MAC with AIRLINE's schedule on a monthly basis and the specific time in advance of the aircraft arrival that AIRLINE requests the Ground Handling Company to be allowed to stage equipment on the Delta designated gate. In most cases, Gate TBD shall be the gate designated by Delta; however this gate assignment is subject to change by Delta based on the operating conditions of any given day.
- B. Provide Delta with as much notice as possible of aircraft arrival and departure time changes that occur for various reasons on a day-to-day basis to ensure proper access to gates and the FIS bag room.
- C. To the best of AIRLINE's ability, ensure only ground handling equipment incidental to the servicing of its aircraft operations may be positioned on the ramp adjacent to the applicable gate. Equipment may be staged on the gate no more than 20 minutes in advance of aircraft arrival and must be removed promptly upon departure of the aircraft.
- D. To the best of AIRLINE's ability, ensure its aircraft does not remain on the gate after arrival any longer than two hours for narrow-body aircraft and three hours for wide-body aircraft. In the event an aircraft is not able to depart the gate within the applicable two or three hour limit and Delta is requiring use of the gate, AIRLINE shall relocate the aircraft to either another gate location designated by Delta or to a remote parking area designated by MAC or MAC's agent. AIRLINE shall be responsible for the cost of parking its aircraft on another gate designated by Delta or within a remote parking area designated by MAC.
- E. AIRLINE assumes responsibility for its above-wing operations through use of AIRLINE's employees or a 3rd party handler.
- F. AIRLINE shall secure ticket counter and outbound baggage areas from MAC and shall be responsible for all costs relating to the use of or construction of such areas.
- G. AIRLINE shall pay MAC all fees related to its use of a gate and the FIS facility as required by the Airline Agreement.
- H. In the event Airline exercises its rights pursuant to Section III.C.3 of the Agreement, AIRLINE agrees to indemnify, defend, save and hold harmless MAC and Delta and their respective Commissioners, officers, and employees (collectively, "Indemnitees") from and against any and all liabilities, losses, damages, suits, actions, claims, judgments, settlements, fines or demands of any person other than an Indemnitee arising by reason of injury or death of any person, or damage to any property, including all reasonable costs for investigation and defense thereof (including but not limited to attorneys' fees, court costs, and expert fees), of any nature whatsoever arising out of or incident to the use or occupancy of, or operations of AIRLINE at or about the Gates unless such injury, death or damage is caused by (i) the negligent act or omission of an Indemnitee whether separate or concurrent with negligence of others, including AIRLINE. MAC and Delta shall give AIRLINE reasonable notice of any such claims or actions. In indemnifying or defending MAC and Delta, AIRLINE shall use legal counsel reasonably acceptable to MAC and Delta and shall control the defense of such claim or action.

**6. Delta's Commitments**

- A. AIRLINE will have gate access in accordance with Article III.C. of the Airline Agreement.
- B. To the best of Delta's ability, the gate designated for AIRLINE's operation shall be clear of Delta's equipment and accessories 30 minutes in advance of the AIRLINE's scheduled arrival.
- C. To the best of Delta's ability, neither Delta nor its equipment shall prevent the Ground Handling Company from reasonable use of and access to the FIS bag room in accordance with this MOU.

**7. Notices**

All notices and other communications under this Agreement shall be effective two (2) business days after deposit with the United States Postal Service, first class, postage prepaid, or when hand delivered or transmitted by Email, and shall be in writing and addressed to the parties at the following addresses:

To Delta: Delta Air Lines, Inc.  
1030 Delta Blvd.  
Atlanta, GA 30320  
Email: hank.moody@delta.com

To AIRLINE: \_\_\_\_\_  
\_\_\_\_\_  
\_\_\_\_\_

To MAC: Metropolitan Airports Commission  
6040 28th Avenue South  
Minneapolis, MN 55450  
Attn: Director, Commercial Management & Airline Affairs

Either party may change the address at which notice is to be made by providing notice of the change to the other party, in writing, in the manner provided for in this Section 6.

**8. Governing Law**

This Agreement shall be governed by and construed in accordance with the laws of the State of Minnesota.

**9. Integration; Amendment and Modification**

This Agreement embodies the entire agreement between the parties hereto relative to the subject matter hereof and shall not be modified, changed or altered in any respect except in writing.

**10. Counterparts**

This Agreement may be executed in two or more counterparts, each of which shall be deemed an original but all of which shall constitute one agreement.

## EXHIBIT Y

## Alternate Rate Structure

Pursuant to Section VI.J of the Agreement, in the event that MAC elects to exercise its rights under that section, MAC shall use the “Alternate Section V.B.” and “Alternate Article VI” below to calculate rates and charges. Capitalized terms in this Exhibit Y shall have the meanings given to them in the Agreement.

## ALTERNATE SECTION V.B. RENTS, FEES, AND CHARGES

## B. RENTS, FEES, AND CHARGES

1. **Landing Fees.** AIRLINE shall pay to MAC monthly landing fees to be determined by multiplying the number of 1,000-pound units of AIRLINE’s Total Landed Weight during the month by the then-current landing fee rate. The landing fee rate shall be calculated according to procedures set forth in Article VI.
2. **Common Use Space Charges.** AIRLINE shall pay for its use of the Common Use Space, calculated according to procedures set forth in Article VI.
3. **Terminal Apron Fees.** AIRLINE shall pay to MAC monthly Terminal Apron fees to be determined by multiplying the number of lineal feet of Terminal Apron Preferential Use Space that is leased to AIRLINE (excluding Concourses A and B) during the month by the then-current Terminal Apron rate. AIRLINE shall pay to MAC monthly Terminal Apron fees associated with the Terminal Apron Preferential Use Space that is leased to AIRLINE for Concourses A and B shall be determined by multiplying the number of lineal feet at the rate of fifty percent (50%) of the lineal feet associated with the Terminal Apron of Concourses A and B during the month by the then-current Terminal Apron rate. The Terminal Apron rate shall be calculated according to the procedures set forth in Article VI hereof.
4. **Terminal 1 Building Rents.** AIRLINE shall pay to MAC monthly Terminal 1 rentals for its Exclusive Use Space (janitored and unjanitored), Preferential Use Space and Joint Use Space in Terminal 1. The Terminal 1 rental rates shall be calculated according to procedures set forth in Article VI.  
 Terminal 1 rentals for Joint Use Space (except the IAF) shall be prorated among Signatory Airlines using the Joint Use Formula.  
 Terminal 1 rentals for Preferential Use Space and Exclusive Use Space shall be determined by multiplying the square feet of the space times the then current Terminal 1 rental rate in accordance with the procedures of Article VI.
5. **Carrousel and Conveyor Charges.** AIRLINE shall pay to MAC monthly carrousel and conveyor charges based upon Operation and Maintenance Expenses and direct depreciation and interest costs. The carrousel and conveyor charges shall be calculated according to the procedures set forth in Article VI and shall be prorated among Signatory Airlines using the Joint Use Formula, provided however, that as long as DELTA operates and maintains the Inbound BHS and Outbound BHS, such costs incurred by DELTA will be charged to AIRLINE as specified in Sections VIII.C and VIII.D.
6. **IAF Gate Fees.** If AIRLINE does not lease the applicable IAF gate as Preferential Use Space, AIRLINE shall pay to MAC monthly IAF gate fees determined by multiplying the number of arrivals at the IAF by AIRLINE’s propeller aircraft, narrow-body jet aircraft, and wide-body jet aircraft by \$400, \$800, and \$1,200, respectively. MAC may reasonably increase these rates at any time with 60 day advance written notice to AIRLINE.

7. **IAF Use Fees.** AIRLINE shall pay to MAC monthly IAF use fees determined by multiplying the number of AIRLINE's international passengers arriving at the IAF during the month by the IAF use fee rate. The IAF use fee rate shall be calculated according to procedures set forth in Article VI.
8. **Other Fees and Charges.** AIRLINE shall pay to MAC reasonable fees for the various other services provided by MAC to AIRLINE. These services include, but may not be limited to, the following:
  - a. Use of Terminal 2 and the Terminal 2 ramp at rates established from time to time by MAC.
  - b. Use of valet parking for AIRLINE's employees at rates set forth in MAC Policies.
  - c. Use of designated employee parking facilities by AIRLINE's employees at rates established from time to time by MAC.
  - d. Nonroutine Terminal Apron cleaning and other special services requested by AIRLINE at rates that reflect the costs incurred by MAC.
  - e. Security and personnel identification badges for AIRLINE's personnel at rates established from time to time by MAC.
  - f. Charges for the cost of separately metered water and sewer and other such utilities not otherwise included in the calculation of rents, fees, and charges.
  - g. Other charges as described in Section VI.M.
  - h. Other charges as described in Section VI.K.

## **ALTERNATE ARTICLE VI. CALCULATION OF RENTS, FEES, AND CHARGES**

### **A. GENERAL**

Each Fiscal Year, rents, fees, and charges will be reviewed and recalculated based on the principles and procedures set forth in this Article VI. The annual costs associated with each of the indirect cost centers shall be allocated to each of the applicable Airport Cost Centers based on the allocations as set forth in Exhibit M, Indirect Cost Center Allocation, which allocations may be reasonably adjusted from time to time by MAC and approved by a Majority-In-Interest of Signatory Airlines. Such approval may not be unreasonably withheld. Such allocation adjustment shall be deemed approved by a Majority-In-Interest of Signatory Airlines unless MAC receives, within forty-five (45) days after emailing or mailing such allocation adjustment: (a) written responses from a Majority-In-Interest of Signatory Airlines and such responses signify that a Majority-In-Interest of Signatory Airlines disapprove of such allocation adjustment or (b) a certificate from the chair of the MSP Airport Affairs Committee stating such disapproval, with supporting documentation establishing that a Majority-In-Interest of Signatory Airlines disapprove of such allocation adjustment.

**B. CALCULATION/COORDINATION PROCEDURES**

1. AIRLINE shall provide to MAC: (a) on or before August 1 of each year a preliminary estimate of Total Landed Weight for the succeeding calendar year of AIRLINE and each Affiliated Airline, unless separately reported to MAC by such Affiliated Airline; and (b) on or before October 1 of each year a final estimate of such weight. If the final estimate is not so received, MAC may continue to rely on the preliminary estimate for the MAC budgeting process. MAC will utilize the forecast in developing its preliminary calculation of Total Landed Weight for use in the calculation of rents, fees, and charges for the ensuing Fiscal Year.
2. On or before October 15 of each Fiscal Year, MAC shall submit to AIRLINE a preliminary calculation of rents, fees, and charges for the ensuing Fiscal Year. The preliminary calculation of rents, fees, and charges will include, among others, MAC's estimate of all revenue items, Operation and Maintenance Expenses, depreciation and imputed interest, Capital Outlays, required deposits, including amounts necessary to be deposited in the Coverage Account in order to meet MAC's rate covenant under the Trust Indenture, and Rentable Space. The calculation of depreciation and imputed interest will be based on MAC's determination of the useful life of each asset and the weighted average cost of capital, respectively, under generally accepted accounting principles, except that unless specifically prohibited by generally accepted accounting principles applicable to a particular project, (a) Terminal 1 projects involving building or structural changes added to the rate calculation after January 1, 1999 and which would otherwise have been depreciated over 20-25 years shall be depreciated over 30 years, and (b) ramp and runway projects involving replacement concrete or ramp work added to the rate calculation after January 1, 1999 and which would otherwise have been depreciated over 20-25 years shall be depreciated over 30 years.
3. Within fifteen (15) days after receipt of the preliminary calculation of rents, fees, and charges, if requested by the Signatory Airlines, a meeting shall be scheduled between MAC and the Signatory Airlines to review and discuss the proposed rents, fees, and charges.
4. MAC shall then complete a calculation of rents, fees, and charges at such time as the budget is approved, taking into consideration the comments or suggestions of AIRLINE and the other Signatory Airlines.
5. If, for any reason, MAC's annual budget has not been adopted by the first day of any Fiscal Year, the rents, fees, and charges for the Fiscal Year will initially be established based on the preliminary calculation of rents, fees, and charges until such time as the annual budget has been adopted by MAC. At such time as the annual budget has been adopted by MAC, the rents, fees, and charges will be recalculated, if necessary, to reflect the adopted annual budget and made retroactive to the first day of the Fiscal Year and any difference shall be charged, credited, or refunded to AIRLINE and paid or credit by AIRLINE or MAC, as applicable, within thirty (30) days thereafter.
6. If, during the course of the year, MAC believes significant variances exist in budgeted or estimated amounts that were used to calculate rents, fees, and charges for the then current Fiscal Year, MAC may after notice to Airlines adjust the rents, fees, and charges for future reports to reflect current estimated amounts.

**C. LANDING FEES**

MAC shall calculate the landing fee rate in the following manner:

1. The total estimated Airfield Cost shall be calculated by totaling the following annual amounts:



- a. The total estimated direct and allocated indirect Operation and Maintenance Expenses allocable to the Airfield cost center.
  - b. The estimated direct and allocated indirect depreciation and imputed interest on the net Capital Cost (after grants and PFCs) allocable to the Airfield cost center. MAC agrees to defer the start of recovery through landing fees of depreciation and imputed interest on \$49.683 million of project costs included in the Runway 17/35 Program from their original date of beneficial occupancy to 2006. Carrying costs for such projects during this deferral period shall be calculated with the amount added to the original project cost (which, if debt funded, includes the allocated portion of capitalized interest, debt service reserve funds, issuance costs, and other such cost elements related to such debt) for recovery through the project's depreciation and imputed interest calculations starting in 2006. Depreciation and imputed interest on these projects shall be recovered over the depreciation periods set forth in Section VI.B.2.
  - c. The estimated imputed interest (net of grants and PFCs) on the historical cost of MAC's investment in land.
  - d. The total estimated direct and allocated indirect cost (net of grants and PFCs) of Capital Outlays allocable to the Airfield cost center.
  - e. The amount of any fine, assessment, judgment, settlement, or extraordinary charge (net of insurance proceeds) paid by MAC in connection with the operations on the Airfield, to the extent not otherwise covered by Article X.
  - f. The amounts required to be deposited to funds and accounts pursuant to the terms of the Trust Indenture, including, but not limited to, its debt service reserve funds allocable to the Airfield cost center. MAC agrees to exclude from the calculation of landing fees the amounts which it may deposit from time to time to the maintenance and operation reserve account and the Coverage Account established and maintained pursuant to the Trust Indenture except for such amounts which are necessary to be deposited to the Coverage Account in order for MAC to meet its rate covenant under the Trust Indenture.
2. The total estimated Airfield Cost shall be adjusted by the total estimated annual amounts of the following items to determine the Net Airfield Cost:
    - a. Service fees received from the military, to the extent such fees relate to the use of the Airfield;
    - b. General aviation and nonsignatory landing fees; and
    - c. Depreciation and imputed interest on the Capital Cost, if any, disapproved by a Majority-In-Interest of Signatory Airlines.
  3. The Net Airfield Cost shall then be divided by the estimated Total Landed Weight (expressed in thousands of pounds) of the Signatory Airlines operating at the Airport to determine the landing fee rate per 1,000 pounds of aircraft weight for a given Fiscal Year.

**D. TERMINAL APRON FEES**

MAC shall calculate the terminal apron rate in the following manner:

1. The total estimated Terminal Apron Cost shall be calculated by totaling the following annual amounts:
  - a. The total estimated direct and allocated indirect Operation and Maintenance Expenses allocable to the Terminal Apron cost center.
  - b. The estimated direct and allocated indirect depreciation and imputed interest on the net Capital Cost (after grants and PFCs) allocable to the Terminal Apron cost center (excluding hydrant fueling repairs and modifications).
  - c. The total estimated direct and allocated indirect cost (net of grants and PFCs) of Capital Outlays allocable to the Terminal Apron cost center.
  - d. The amounts required to be deposited to funds and accounts pursuant to the terms of the Trust Indenture, including, but not limited to, its debt service reserve funds allocable to the Airfield cost center. MAC agrees to exclude from the calculation of landing fees the amounts which it may deposit from time to time to the maintenance and operation reserve account and the Coverage Account established and maintained pursuant to the Trust Indenture except for such amounts which are necessary to be deposited to the Coverage Account in order for MAC to meet its rate covenant under the Trust Indenture.
2. The Terminal Apron Cost shall then be divided by the total estimated lineal feet of Terminal Apron, to determine the terminal apron rate per lineal foot for a given Fiscal Year. For the purposes of this calculation, lineal feet of Terminal Apron shall be computed as the sum of the following:
  - a. Lineal feet of the Terminal Apron (excluding the Terminal Apron associated with Concourses A & B); and
  - b. Fifty percent (50%) of lineal feet of the Terminal Apron associated with Concourse A & B.

#### **E. TERMINAL 1 RENTS**

MAC shall calculate the Terminal 1 rental rate for unjanitored and janitored space in Terminal 1 as set forth in Subsections 1 and 2 of this Section.

1. MAC shall calculate the Terminal 1 rental rate for unjanitored space in Terminal 1 in the following manner and as illustrated in Exhibit N.
  - a. The total estimated Terminal Building Cost shall be calculated by totaling the following annual amounts:
    - 1) The total estimated direct and allocated indirect Operation and Maintenance Expenses allocable to the Terminal 1 cost center.
    - 2) The estimated direct and allocated indirect depreciation and imputed interest on the net Capital Cost (after grants and PFCs) allocable to the Terminal 1 cost center. MAC agrees to defer the start of recovery through Terminal 1 rents of depreciation and imputed interest on \$121.574 million of project costs included in the Green Concourse Extension Program from their original date of beneficial occupancy to 2006. Carrying costs for such projects

during this deferral period shall be calculated with the amount added to the original project cost (which, if debt funded, includes the allocated portion of capitalized interest, issuance costs, and other such cost elements related to such debt) for recovery through the project's depreciation and imputed interest calculations starting in 2006. Depreciation and imputed interest on these projects shall be recovered over the depreciation periods set forth by in Section VI. B. 2.

- 3) The total estimated direct and allocated indirect cost (net of grants and PFCs) of Capital Outlays allocable to the Terminal 1 cost center.
  - 4) The amounts required to be deposited to funds and accounts pursuant to the terms of the Trust Indenture, including, but not limited to, its debt service reserve funds allocable to the Airfield cost center. MAC agrees to exclude from the calculation of landing fees the amounts which it may deposit from time to time to the maintenance and operation reserve account and the Coverage Account established and maintained pursuant to the Trust Indenture except for such amounts which are necessary to be deposited to the Coverage Account in order for MAC to meet its rate covenant under the Trust Indenture.
- b. The total estimated Terminal Building Cost shall be reduced by the total estimated annual amounts of the following items to determine the Net Terminal Building Cost:
- 1) Reimbursed expense:
    - a) IAF Operation and Maintenance Expenses;
    - b) Carrousel and conveyor Capital cost and Operation and Maintenance Expense;
    - c) Ground power;
    - d) Loading dock;
    - e) Concession utilities, and
    - f) Items described in Section VI.K and VI.M. to the extent directly reimbursed.
  - 2) Janitorial Operation and Maintenance Expenses, as incurred by MAC.
- c. The Net Terminal Building Cost shall then be divided by the total estimated Rentable Space in the Terminal 1 to determine the Terminal 1 rental rate per square foot for unjanitored space for a given Fiscal Year. (See Initial Rentable Square Footage, Exhibit O).
2. MAC shall calculate the Terminal 1 rental rate for janitored space by totaling the following rates:

- a. The Terminal 1 rental rate per square foot for unjanitored space for a given Fiscal Year, as calculated in this Section; and
- b. An additional rate per square foot, the janitored rate, calculated by dividing the total estimated direct janitorial Operation and Maintenance Expenses, as determined by MAC, by the total janitored space in the Terminal 1 (excluding MAC and mechanical space).

**F. CARROUSEL AND CONVEYOR CHARGE**

1. MAC shall calculate the carrousel and conveyor charge, by totaling the following annual amounts: equipment charges associated with the carrousel and conveyor, including annual depreciation and imputed interest, Operation and Maintenance Expense, and service charge.
2. MAC shall prorate the carrousel and conveyor charge among the Signatory Airlines using the Joint Use Formula.
3. Notwithstanding anything herein to the contrary, so long as DELTA operates and maintains the Inbound BHS and Outbound BHS, such costs incurred by DELTA will be charged to AIRLINE as specified in Sections VIII.C and VIII.D.

**G. IAF USE FEES**

The IAF use fee for use of the IAF and any associated gates shall be based upon:

1. The cost of the maintenance and operation of the International Arrivals Facility which may include, but is not limited to:
  - a. utilities;
  - b. cleaning;
  - c. maintenance (including the costs of maintaining the security equipment that existed as of April 1998), repair and replacement cost allocation;
  - d. police, fire, and administrative cost allocation;
  - e. costs of providing passenger baggage carts, if any;
  - f. costs of providing staff parking for federal inspections agency staff; and
  - g. \$35,064 per month for recoupment for lost rental area in the G Concourse.
2. Costs associated with the operation of dual international arrivals facility locations at the Airport, based on the appropriate allocation of costs between the two facilities, not otherwise funded by the federal inspections agencies including, but not limited to additional personnel and equipment used by those agencies; and
3. Excess construction and financing costs, if any.

Each Fiscal Year, the IAF use fee shall be calculated by first summing the budgeted costs for items (1) through (4) above and then dividing by total estimated passengers arriving at the IAF. AIRLINE shall be billed for IAF use fees monthly, and such use fees shall be set annually at an estimated charge through MAC's budget process and then adjusted at year end for actual costs and actual passengers arriving at the IAF pursuant to certified audit by MAC's external auditors and such difference shall be charged, refunded, or credited to AIRLINE and paid or credited by AIRLINE or MAC within thirty (30) days thereafter.

On a monthly basis for compensation for use of gates G1-G10 for scheduled international aircraft arrivals, MAC shall pay DELTA, \$400, \$800 and \$1,200, for each arrival by, respectively, propeller aircraft, narrow-body jet aircraft or wide-body aircraft at the IAF. MAC may reasonably increase these rates at any time with 60 day advance written notice to DELTA.

#### **H. YEAR-END ADJUSTMENTS OF RENTS, FEES, AND CHARGES**

1. As soon as practical following the close of each Fiscal Year, but in no event later than July 1, MAC shall furnish AIRLINE with an accounting of the costs actually incurred and revenues and credits actually realized during such Fiscal Year with respect to each of the components of the calculation of the rents, fees, and charges calculated pursuant to this Section broken down by rate making Cost Center.
2. In the event AIRLINE's rents, fees, and charges billed during the Fiscal Year exceed the amount of AIRLINE's rents, fees, and charges required (as recalculated based on actual costs and revenues), such excess shall be refunded or credited to AIRLINE.
3. In the event AIRLINE's rents, fees, and charges billed during the Fiscal Year are less than the amount of AIRLINE's rents, fees, and charges required (as recalculated based on actual costs and revenues), such deficiency shall be charged to AIRLINE in a supplemental billing.
4. This section does not apply to Common Use Space charges. This provision shall survive an expiration or termination of this Agreement.

#### **I. [INTENTIONALLY OMITTED]**

#### **J. [INTENTIONALLY OMITTED]**

#### **K. AIRLINE SERVICES PROVIDED BY MAC IN TERMINAL 1**

##### **1. SCOPE AND COSTS**

In accordance with the terms of this Section VI.K, AIRLINE agrees to reimburse MAC for providing the services described in this Section that generally benefit the Signatory Airlines using Terminal 1 or that primarily benefit AIRLINE. Except as and to the extent set forth in Section VI.K.4. below, MAC is under no obligation to provide any of these airline services. However, if MAC agrees to provide the services it shall charge AIRLINE as specified in this Section VI.K.

##### **2. EXISTING SERVICES**

For existing services historically provided by Airlines, the costs of providing such services will be recovered by MAC as follows: (a) if the services generally benefit the Airlines utilizing Terminal 1, the costs will be assessed using the Joint Use Formula; or (b) if the services primarily benefit a limited number of Airlines utilizing Terminal 1, MAC will directly bill those Airlines benefiting from the services their pro rata share based on Enplaned Passengers.

These airline services include but are not limited to porter services, security line management services, and technology related services such as flight information displays, ticket counter back wall monitors, and content management systems (but exclude future services, Employee Screening services, and services addressed elsewhere in this Agreement), the costs of which are not otherwise included in and recovered through the other rents, fees and charges assessed under this Article VI. Additionally, these airline services shall also include security costs for law enforcement officers within the ticketing or baggage claim or concourse areas of Terminal 1 to the extent these law enforcement officers are specifically requested by one or more Signatory Airlines and are in addition to the law enforcement officers MAC typically provides.

### 3. **FUTURE SERVICES**

For future related airline services provided by MAC, AIRLINE shall reimburse MAC for the costs of such services in the manner described in Section VI.K.2, unless such costs are disapproved by a Majority-In-Interest of the Terminal 1 Signatory Airlines in accordance with the procedures in Section VII.B.1. Majority-In-Interest review shall not be required any services that primarily benefit a limited number of Airlines if those Airlines agree to pay for and be directly billed for those services.

### 4. **TERMINAL 1 AIRLINE EMPLOYEE SCREENING**

Effective January 1, 2019, MAC shall begin performing (through a 3rd party contractor) the screening of AIRLINE's and its contractors' and subcontractors' employees who enter secure areas from within Terminal 1 ("Employee Screening."). This does not include AIRLINE employees entering secure, SIDA, or AOA areas from outside Terminal 1 such as the Airfield gates or other buildings at the Airport. The indemnification obligations of AIRLINE set forth in Section IX.A shall apply to this Section. MAC shall have sole and absolute discretion establishing Employee Screening locations and, subject to fulfilling its obligations in this Section, MAC makes no guarantee that existing AIRLINE or MAC screening locations will continue to be operated or available for screening functions; provided, however, that such locations shall be sufficient to perform the Employee Screening in a timely manner. Should MAC elect not to provide Employee Screening at an existing AIRLINE operated Employee Screening location, AIRLINE may continue to provide Employee Screening for its own employees and contractors at its own cost and expense at such location, provided that MAC may require such location to be closed at any time, in MAC's sole discretion, and AIRLINE may elect to close such location at any time. Employee Screening will be performed at locations that screen employees of other tenants, contractors, and subcontractors at the Airport and/or MAC's and its contractors' and subcontractors' employees. At any time, MAC may elect to transfer responsibility for Employee Screening to the Transportation Security Administration (or successor agency) if and to the extent the Transportation Security Administration (or successor agency) is willing to assume such responsibility, and AIRLINE shall reasonably cooperate with MAC to facilitate such move. Any expense MAC incurs for Employee Screening attributed to Signatory Airlines will be prorated among the Signatory Airlines using the Joint Use Formula and AIRLINE's proportionate share shall be billed to AIRLINE directly. MAC may, upon 365 days' advance notice to AIRLINE, stop performing Employee Screening.

**L. TERMINAL 1 COMMON USE SPACE CHARGES**

Use of and charges for Common Use Space in Terminal 1 shall be governed under a Memorandum of Understanding between MAC and any Airline that desires to use such Common Use Space at Terminal 1. AIRLINE agrees that such Memorandum of Understanding will be superseded and no longer in effect if a MAC Ordinance and/or Rules or Regulations are adopted that governs use of and charges for Common Use Space at Terminal 1.

**M. MAC-OWNED SYSTEMS AND EQUIPMENT AND UTILITIES INSURANCE COSTS**

MAC may seek to procure certain insurance policies, additional coverages and/or additional limits for the benefit of MAC and/or Airlines that insure against losses incurred by MAC and/or Airlines related to the failure or outage of MAC-Owned Systems and Equipment and/or the failure or outage of utilities or services described in Section VIII.A.4 (such as power, water, gas, fiber, HVAC, etc.). In connection with such procurement, upon AIRLINE's timely request, AIRLINE shall have the opportunity to participate in the procurement and review of any such insurance policies (including the continuation of policies not yet in place as of the effective date of this Agreement if premiums will increase by more than 10%), and MAC shall consider, in good faith, AIRLINE's comments, position, and concerns regarding such procurement. If any such policies are procured, AIRLINE shall reimburse MAC for premiums and other related costs of such insurance policies in the manner described below, unless such insurance policies are disapproved by a Majority-In-Interest of Signatory Airlines in accordance with the procedures in Section VII.B.1 and as modified below, in which case MAC may still elect to procure such insurance policies, but may not charge such insurance premium costs directly to Airlines, but such insurance premium costs will be reasonably allocated by MAC to all Airport Cost Centers that benefit from such insurance policies. Eighty percent (80%) of the premium costs for such insurance policies that are not disapproved by a Majority-In-Interest of Signatory Airlines (except that, for purposes of disapproval under this section, the MII rules will be altered by replacing references to a majority of all Signatory Airlines with reference to a majority of all Signatory Airlines responding to the notice) shall be allocated on a reasonable basis by MAC to Terminal 1 and Terminal 2, and twenty percent (20%) of such premium costs shall be reasonably allocated to other Airport Cost Center(s) that benefit from such insurance policies. Such insurance premium costs allocated to Terminal 1 will be charged to Terminal 1 Signatory Airlines using the Joint Use Formula. Such allocated insurance premium costs allocated to Terminal 2 will be included in Terminal 2 rates and charges prescribed by MAC Ordinance. Notwithstanding anything herein to the contrary, any insurance policies procured under this Section VI.M. shall be primary with respect to any damages covered thereby and respond prior to any insurance AIRLINE is required to maintain hereunder, provided that where more than one party is at fault each party's insurance shall be primary with respect to that party's portion of the liability.

**EXHIBIT Z**  
**SUN COUNTRY ONLY PROVISIONS**

**I. DEFINITIONS**

- A. "Sun Country" means MN Airlines LLC, d.b.a Sun Country Airlines

**II. COMMUNITY NOISE GROUP**

The MSP Noise Oversight Committee (NOC) was established in August 2002 as an advisory board appointed to address aircraft noise issues associated with MSP, and SUN COUNTRY and MAC agree to participate in the NOC, or any successor organization or other organization in lieu thereof that is formed principally to explore programs and procedures working toward the goal of mitigating the impacts caused by aircraft noise.



**Certain identified information has been excluded from this exhibit because it is both (i) not material and (ii) would be competitively harmful if publicly disclosed. [\*\*\*] indicates that information has been redacted.**

**AIR TRANSPORTATION SERVICES AGREEMENT**

DATED AS OF DECEMBER 13, 2019

BETWEEN

SUN COUNTRY, INC.

AND

AMAZON.COM SERVICES, INC.

## TABLE OF CONTENTS

<b>1. DEFINITIONS</b>	<b>1</b>
<b>2. SERVICES</b>	<b>8</b>
2.1 Services	8
2.2 Third Party Carriers	8
2.3 Forecasts and Non-Binding Estimates	9
2.4 Service Levels; Reporting	9
2.5 Non-Reimbursable Expenses	9
2.6 Reimbursable Expenses	10
2.7 Fuel	12
2.8 Ground Handling; ULDs	12
2.9 Training Provided by the Carrier	15
2.10 Schedule; Modifications	16
2.11 Aircraft Operations	17
2.12 Operations for Third Parties	19
2.13 Force Majeure	20
2.14 Unavailability	21
2.15 Destruction or Casualty Loss of Aircraft	21
2.16 Sustainability; Fuel Conservation	21
2.17 Reports, Audits and Record Retention	22
2.18 Access to Information Technology Systems	23
2.19 Designated Point of Contact	23
2.20 Continuous Improvement	23
2.21 Aircraft Maintenance Technician	24
2.22 IATA BSP; Electronic Data Interchange	24
2.23 Maintenance Process	24
<b>3. PAYMENT</b>	<b>24</b>
3.1 Fixed Monthly Charge; Variable Charges	24
3.2 Startup Costs.	24
3.3 Payment for Cancellation of Flights	24
3.4 Invoices and Payment	25
<b>4. TERM AND TERMINATION</b>	<b>25</b>
4.1 Term; Renewal Option	25
4.2 Amazon Terminations	25
4.3 Payment of Amazon Termination Fee	25
4.4 Sun Country Termination for Convenience	26
4.5 Events of Default; Remedies	26
4.6 No Termination or Other Payment on Expiration	27
4.7 Work Orders	28
4.8 Subleases	28
4.9 Post-Expiration Agreement	28
4.10 Survival	28

<b>5. REPRESENTATIONS AND WARRANTIES; COVENANTS</b>	<b>28</b>
5.1 Authority	28
5.2 Organization; Binding Agreement	29
5.3 Service Representations	29
5.4 Proprietary Rights	29
5.5 Compliance	29
5.6 Common Carrier	30
5.7 Filings	30
5.8 No Liens	30
5.9 Flight Operations	30
5.10 Trade Restrictions	31
<b>6. CONFIDENTIALITY; PROPRIETARY RIGHTS</b>	<b>31</b>
6.1 Confidentiality	31
6.2 Publicity Restriction	32
6.3 Work Product Ownership	32
6.4 Personal Information	32
<b>7. DEFENSE/INDEMNITY</b>	<b>33</b>
<b>8. LOSS OR DAMAGE TO GOODS</b>	<b>35</b>
8.1 Liability Limit	35
8.2 Additional Coverage	35
8.3 Claims	35
8.4 Cooperation	35
<b>9. INSURANCE</b>	<b>36</b>
9.1 Sun Country Provider Insurance Coverage	36
9.2 Additional Policy Requirements	37
9.3 Amazon Insurance	38
<b>10. PERSONNEL; INDEPENDENT CONTRACTORS</b>	<b>38</b>
10.1 Relationship of the Parties	38
10.2 Personnel	38
10.3 Subcontractors	39
<b>11. TAXES</b>	<b>40</b>
<b>12. CARRIER WORK ORDERS AND AIRCRAFT SUBLEASES</b>	<b>40</b>
12.1 Committed Aircraft.	40
12.2 Additional Aircraft.	41
12.3 Delivery Process; Modifications	41
<b>13. GENERAL</b>	<b>41</b>
13.1 Assignment or Change of Control by Sun Country Providers	41
13.2 Assignment by Amazon	42
13.3 Governing Law/Venue	42

13.4	Notices	42
13.5	Amendment and Waiver	42
13.6	Remedies	43
13.7	Construction	43
13.8	Third Party Shippers	43
13.9	Work Orders	44
13.10	Hazardous Materials Notifications	44
13.11	Counterparts	44
13.12	LIMITATION OF LIABILITIES	44
13.13	Entire Agreement	45
13.14	Cooperation	45
13.15	Further Assurances	45
13.16	Priority Over Standard Forms	46

Exhibit A: Committed Aircraft

Exhibit B: Form of Carrier Work Order

Exhibit C: Performance Standards

Exhibit D: Invoices; Payments; Deposits; Weekly Statement

Exhibit E: Form of Aircraft Sublease Agreement

Exhibit F: Price Schedule

Exhibit G: USPS Provisions

Exhibit H: Aircraft Delivery Specification & Modifications

**AIR TRANSPORTATION SERVICES AGREEMENT**

This Air Transportation Services Agreement, attached Exhibits and Schedules, and applicable Work Orders (collectively, this “Agreement”) dated as of December 13, 2019 (“Effective Date”) is entered into between Sun Country, Inc., a corporation organized and existing under the laws of the State of Minnesota (“Sun Country”), and Amazon.com Services, Inc., a corporation organized and existing under the laws of the State of Delaware (“ASI”).

**RECITALS**

Sun Country, through the Sun Country Providers, provides air cargo transportation and related services;

Amazon operates an international e-commerce business distribution network; and

The Parties desire to enter into an arrangement for Sun Country to provide air cargo transportation and related services to Amazon pursuant to the terms and conditions of this Agreement.

The Parties also desire to have Sun Country issue warrants to Amazon.com, Inc. (a Delaware corporation of which ASI and its Affiliates are wholly owned subsidiaries) to purchase shares representing a total of 15% of Sun Country’s common stock.

In consideration of the premises, and of the representations, warranties, covenants, and agreements set forth herein, and intending to be legally bound, the signatories to this Agreement agree as set forth herein.

**AGREEMENT**

**1. DEFINITIONS**

“Additional Aircraft” means any Aircraft not listed in Exhibit A that becomes subject to a Sublease between Amazon and a Carrier after the Effective Date.

“Additional Insureds” is defined in Section 9.2.

“Affiliate” means, with respect to a specified entity, any other entity that, directly or indirectly, controls, is controlled by, or is under common control with such specified entity, where “control” means the possession, direct or indirect, of the power to direct or cause the direction of the management and policies of an entity, whether through the ownership of voting securities, or otherwise, provided that when used herein Apollo Global Management and its subsidiaries shall not be deemed Affiliates of Sun Country or any Sun Country Provider.

“Agreed Value” means the Agreed Value specified in an Aircraft Sublease.

“Agreement” is defined in the Preamble.

“Aircraft” means: (a) the Committed Aircraft and any Additional Aircraft; (b) unless otherwise specified, any Spare Aircraft, Substitute Aircraft, or Network Spare; and (c) any other aircraft to be operated under this Agreement as agreed to by the Parties.

“Aircraft Sublease” means a sublease for an Aircraft entered into between Amazon (or one of its Affiliates) and a Carrier under this Agreement.

“Amazon” means collectively, unless otherwise specified, ASI and any of its Affiliates for which a Sun Country Provider performs Services pursuant to a Work Order in accordance with Section 13.9.

“Amazon Indemnified Parties” is defined in Section 7.1.

“Amazon Leadership Representative” means a Vice President of Amazon, or such individual(s) as Amazon may designate from time to time in writing.

“Amazon Parties” is defined in Section 9.1.5.

“Amazon Spare Request” is defined in Section 2.11.2.

“Amazon Subcontractor Claim” is defined in Section 10.3.

“Amazon Termination Fee” is defined in Section 4.2.

“Arrival Performance” is defined in Section 4 of Exhibit C.

“ASI” is defined in the Preamble.

“Availability Window” means a time period designated by Amazon on the Flight Schedule during which the Carrier will staff a Network Spare so as to be available to depart its current location within [\*\*\*] minutes of Amazon’s request.

“Block Hour” means each hour that the Aircraft is operated on a flight in the performance of the Services, computed from removal of the wheel chocks from the front of the Aircraft until the placement of wheels chocks in front of the Aircraft at the end of such flight and rounded to the nearest tenth of an hour.

“Boeing” means The Boeing Company.

“Business Days” is defined in Section 13.7.

“Carrier” is defined in Section 2.2.

“Carrier Delay” is defined in Exhibit C.

“Carrier Work Order” is defined in Section 2.2.

“Carrier Work Order Term” is defined in Section 3.1.

“Change Fee” is defined in Section 2.10.2.

“Change of Control” means, with respect to SCA Acquisition Holdings, Sun Country, or a Sun Country Provider: (a) other than in connection with an initial public offering, any consolidation, merger, reorganization, or similar transaction involving SCA Acquisition Holdings or its subsidiaries (for clarity, including Sun Country or any Sun Country Provider) in which SCA Acquisition Holdings, as applicable, is not the surviving entity or pursuant to which SCA Acquisition Holdings’ equityholders immediately prior to such transaction own, immediately after such transaction, less than 50% of the voting securities of the applicable surviving entity, or (b) other than in connection with an initial public offering, any transaction or series of related transactions in which 50% or more of SCA Acquisition Holdings, Sun Country, or a Sun Country Providers’ voting power is transferred to persons other than SCA Acquisition Holdings’ equityholders immediately prior to such transaction or series of transactions, (c) the sale, lease, exclusive license, or other transfer, in any transaction or series of related transactions, of all or substantially all of the assets of SCA Acquisition Holdings, Sun Country or any Sun Country Provider.

“Charters” is defined in Section 2.12.2.

“Claims” is defined in Section 7.1

“Committed Aircraft” means the 10 Boeing 737-800 Aircraft listed in Exhibit A that will be leased to Amazon by a third party lessor.

“Common Carrier” means an individual, a company, or a public utility that is in the regular business of providing transportation services or transporting people or freight (as distinguished from a private carrier that only transports occasionally or as a one-time-only event).

“Compliance Requirements” is defined in Section 5.5.

“Contract Year” means each period during the term of this Agreement beginning December 13 through the next following December 12.

“Effective Date” is defined in the Preamble.

“ETOPS” is defined in Section 2.5.1.

“Event of Default” is defined in Section 4.5.

“Excluded Claims” is defined in Section 8.1.

“Expiration Date” is defined in Section 4.7.

“FAA” means the United States Federal Aviation Administration.

“Fixed Monthly Charge” is defined in the Price Schedule.

“Flight Crew” means a flight crew consisting of one captain and one first officer.

“Flight Cycle” means a cycle consisting of one takeoff and one landing.

“Flight Operations Requirements” is defined in Section 5.9.

“Flight Schedule” is defined in Section 2.10.1.

“Force Majeure” is defined in Section 2.13.

“Fuel Optimization Program” is defined in Section 2.16.1.

“GOM” means a Carrier’s FAA-approved Ground Operations Manual.

“Governmental Entity” means: (a) any national government, any political subdivision thereof, or local authority therein, whether foreign or domestic; (b) any agency, board, commission, department, division, organ, instrumentality, or court of any of the foregoing, however constituted; and (c) any organization, association, or institution, of which any of the foregoing is a member or to whose jurisdiction it is subject or in whose activities it is a participant.

“GPU” means ground power unit.

“Ground Services Work Order” is defined in Section 2.8.1.

“Hazardous Materials” is defined in Section 13.10.

“Heavy Maintenance” means: (a) C-Checks and above (including structural inspection program and Airworthiness Limitation Item (AWL) inspections, but excluding Sun Country C Check Costs); (b) overhaul of landing gear (including overhaul of rotatable components accomplished concurrently with landing gear overhaul); (c) Performance Restorations of engines and APUs; (d) to the extent occurring concurrently with or separately from a Performance Restoration of an engine or APU, the replacement of engine life limited parts (or, for clarity, the replacement of an entire engine or APU) and maintenance performed specifically to accomplish such replacement; and (e) the repair of airframe structural issues that would not have been reasonably discovered [\*\*\*], in each case to the extent not related to or arising out of an act or omission of a Carrier or otherwise the responsibility of a Sun Country Provider under this Agreement or the applicable Aircraft Sublease.

“IATA” means the International Air Transportation Association.

“ICAO” means the International Civil Aviation Organization.

“Income Taxes” is defined in Section 11.

“Insurance Requirements” is defined in Section 9.2.



“Law” means: (a) any statute, regulation, by-law, ordinance, or subordinate legislation in force to which a Party is subject including all Federal and state securities laws; (b) the common law as applicable to the Parties; (c) any binding court order, judgment, or decree; (d) any applicable industry code, policy or standard, in each case enforceable by law; and (e) all applicable statutory and all other rules, guidance regulations, instruments and provisions in force including the rules, codes of conduct, codes of practice, practice requirements guidance, and accreditation terms stipulated by any Governmental Entity to which any Party is subject.

“LIBOR” means the average of the London interbank offered rate for deposits in U.S. dollars as set forth by the Bloomberg Information Service (or any successor benchmark commonly accepted as a replacement to LIBOR) determined as of approximately 11:00 a.m. (London time) for each day that the relevant interest accrues.

“Maintenance Fuel” means any aircraft fuel used outside of the loading/unloading process in connection with maintenance (e.g., for engine runs or to power the APU), calculated using a deemed fuel burn rate of [\*\*\*] lbs. of fuel per hour.

“Monthly Invoice” is defined in Exhibit D.

“NDA” is defined in Section 6.1.

“Network Spare” is defined in Section 2.11.3.

“NTSB” means the National Transportation Safety Board.

“Operating Authority” is defined in Section 5.9.

“Party” means Sun Country and ASI and, as applicable, any Sun Country Provider or Amazon to the extent that such Sun Country Provider or Amazon is a party to a current Work Order.

“Pay-Protected Block Hours” means the Block Hours representing the minimum amount of time to which a pilot is assigned to, and is guaranteed to be paid by Carrier for, according to the Flight Schedule [\*\*\*], all in accordance with the Carrier’s collective bargaining agreement.

“Performance Restoration” means: (a) with respect to an engine, the performance of engine maintenance accomplished in accordance with the original equipment manufacturer’s Workscope Planning Guide (WPG) and Engine Shop Manual (ESM), including at a minimum, a performance restoration workscope (or overhaul) for such engine’s high pressure compressor, combustor and high pressure turbine modules, together with other work conducted on any other of such engine’s modules, as required by the ESM, which is intended to restore the hardware integrity of the flow path and performance of the engine; and (b) with respect to an APU, the performance of any uninstalled APU maintenance.

“Performance Standards” is defined in Section 2.4.

“Person” means any body, corporate entity, association, partnership, joint venture, organization, individual, business or other trust or any other entity or organization of any kind or character, including a court or other Governmental Entity.

“Personal Information” is defined in Section 6.4.

“Personnel” means the employees, contractors, subcontractors, agents, and representatives of an entity.

“Post-Expiration Agreement” is defined in Section 4.9.

“Price Schedule” means: (a) with respect to Carrier Work Orders, the Price Schedule attached as Exhibit F to this Agreement; and (b) with respect to all other Work Orders, the Price Schedule attached to such Work Order.

“Proprietary Rights” is defined in Section 5.4.

“Records” is defined in Section 2.17.

“Remaining Pay-Protected Block Hours” the number of Pay-Protected Block Hours for which Carrier must pay a pilot after the following: [\*\*\*].

“Rotation” means a flight or a series of flights, in a duty day, to which a crew has been assigned according to the Flight Schedule in accordance with the Carrier’s collective bargaining agreement.

“Rotation Change” means either that Amazon either: (a) completely cancels a Rotation; or (b) changes a rotation [\*\*\*].

“SCA Acquisition Holdings” means SCA Acquisition Holdings, LLC, the parent company of Sun Country.

“Scheduled Termination Date” means the date immediately preceding the six year anniversary of the Work Order Effective Date of the first Carrier Work Order entered into under this Agreement.

“Scheduling Constraints” means, collectively: (a) flight or duty limits under the applicable FAA regulations or the Carrier’s collective bargaining agreement with its pilot employees; (b) landing and/or take-off curfews or slot restrictions; (c) regularly scheduled aircraft maintenance requirements as provided for in the Carrier’s FAA-approved maintenance program (subject to Section 2.11.1); (d) flight times based on Boeing’s 85% average winds, adjusted twice each year for seasonal changes; (e) historical taxi times (time of day and seasonally adjusted); and (f) other industry standard material operational factors, including air traffic control, airport-specific congestion, and seasonality constraints from mutually agreed sources.

“Security Programs” is defined in Section 2.8.3.

“Services” is defined in Section 2.1.

“Services Commencement Date” means the date that Sun Country will begin providing Services using an Aircraft and, with respect to the Committed Aircraft, is listed in Exhibit A.

“SGHA” is defined in Section 2.8.1.

“Spare Aircraft” is defined in Section 2.11.2.

“Substitute Aircraft” is defined in Section 2.11.1.

“Sun Country” is defined in the Preamble.

“Sun Country C Check Costs” means the costs (including labor, materials, and ancillary costs) of the following, all of which, for clarity, will be the responsibility of Sun Country even if performed in connection with a C check: (i) all engineering orders with an inspection or performance interval of less than [\*\*\*] flight hours, [\*\*\*] Flight Cycles, or [\*\*\*] months, as applicable; and (ii) tasks with an inspection or performance interval less than or equal to [\*\*\*] days.

“Sun Country Indemnified Parties” is defined in Section 7.3.

“Sun Country Providers” means collectively, unless otherwise specified, any Sun Country Affiliate that performs Services for Amazon pursuant to a Work Order in accordance with Section 13.9.

“Sun Country Subcontractor Claim” is defined in Section 10.3.

“Supplemental Flying” is defined in Section 2.12.

“Taxes” is defined in Section 11.

“Temporary Schedule Change” is defined in Section 2.10.3.

“Third Party Carrier” is defined in Section 2.2.

“Third Party Shipper” is defined in Section 13.8.

“Training” is defined in Section 2.9.

“Transfer Taxes” is defined in Section 11.

“TSA” means United States Transportation Security Administration.

“Two-Six Window” means, with respect to a change in the Flight Schedule, the period of time [\*\*\*].

“Unit Load Devices” or “ULDs” is defined in Section 5.9.

“Unscheduled Stop” means an aircraft stop requested by Amazon that adds another destination/stop to a route contained in the Flight Schedule.

“USPS” is defined in Section 2.8.11.

“USPS Prime Contracts” is defined in Section 2.8.11.

“Variable Charge Per Block Hour” means the rate specified in the Price Schedule for each Block Hour (or portion thereof) flown by an Aircraft in the performance of the Services.

“Variable Charge Per Cycle” means the rate specified in the Price Schedule for each Flight Cycle flown by an Aircraft in the performance of the Services.

“Variable Charges” means, collectively, the Variable Charge Per Block Hour and the Variable Charge Per Cycle.

“Weekly Activity Statement” is defined in Section 3 of Exhibit D.

“Weekly Fuel Charge” means the actual amount to be reimbursed by Amazon to Sun Country Providers in accordance with Sections 2.6 and 2.7 of the Agreement during each week for aircraft fuel and into-plane services purchased by Sun Country and any Sun Country Provider for Services provided by the Carriers.

“Work Order” means a Carrier Work Order, Ground Services Work Order, or any other work orders entered into under this Agreement.

“Work Order Effective Date” is defined in the relevant Work Order.

## **2. SERVICES**

2.1 Services. Sun Country will provide, by itself or through Sun Country Providers, the air cargo transportation, ground handling, fuel, and other related services described in this Section 2 and in the Work Orders entered into between Amazon and Sun Country or any Sun Country Provider (collectively, the “Services”). Other than Aircraft that Carriers may sublease from Amazon and ground equipment or functions that Amazon may be responsible for pursuant to Section 2.5, Sun Country and the Sun Country Providers will provide all equipment, Personnel, software, and supplies required to perform the Services.

2.2 Third Party Carriers. With the prior written consent of an Amazon Leadership Representative (which may be granted or withheld in Amazon’s sole discretion), Sun Country may contract for the performance of Services with one or more third party certificated cargo air carriers (a “Third Party Carrier”). Sun Country and any Third Party Carrier is referred to individually as a “Carrier.” References to Third Party Carriers in this Agreement does not imply that the use of Third Party Carriers will be permitted and, if Amazon consents to the use of a Third Party Carrier: (a) Amazon’s payment obligations will not exceed the amount that would have been paid by Amazon had the flights been operated by Sun Country under the relevant Carrier Work Order; and (b) Sun Country will be solely responsible for the performance of the Third Party Carrier with respect to the determination of whether Sun Country has met the Performance Standards. Sun Country will remain jointly and severally responsible for the provision of Services notwithstanding any contracting of Services to any Carrier. Each Carrier performing Services under this Agreement will enter into a Carrier Work Order in the form of Exhibit B (a “Carrier Work Order”).

2.3 Forecasts and Non-Binding Estimates. Except as expressly provided in this Agreement, Amazon makes no promises or representations whatsoever as to the amount of business Sun Country or any of the Carriers can expect at any time under this Agreement. Amazon may give volume and other projections to Sun Country or any Carrier, but any projections are speculative only and will not give rise to Amazon liability. Amazon may, in Amazon's sole discretion, engage the services of other companies that perform the same or similar services as those provided by the Sun Country and/or the Sun Country Providers.

2.4 Service Levels; Reporting. Sun Country and the Sun Country Providers will comply with the service levels, procedures, reporting requirements, tracking requirements, and other performance standards set forth in the attached Exhibit C or any applicable Carrier Work Order (the "Performance Standards").

2.5 Non-Reimbursable Expenses. Sun Country (by itself or through the applicable Sun Country Provider) will be responsible for and provide, or cause to be provided, the following Personnel, services, equipment, and other items at their expense, without reimbursement by Amazon:

2.5.1 Flight Crews which will: (a) possess current, valid licenses; (b) be fully qualified to operate the Aircraft on the Flight Schedule in compliance with all applicable Laws; (c) be employees of the Carrier; and (d) as required to provide Services in support of the Flight Schedule, be qualified for Extended-range Twin-engine Operational Performance Standards ("ETOPS") (provided that Amazon will give at least [\*\*\*]advance notice (including through the Flight Schedule) of any intended operation requiring ETOPS qualification and will be responsible for any documented costs agreed in writing in advance associated with making an Aircraft ETOPs qualified).

2.5.2 For each Flight Crew: (a) operational oversight and training; (b) catering and meals; (c) visas, work permits, endorsements, airport ID/badges/access cards; and (d) compensation, benefits, transportation, hotel accommodations, and per diem, as well as any increases in such expenses resulting from changes to, or in the interpretation of, the Carrier's collective bargaining agreements (unless directly attributable to a change in applicable Law relating directly to crew duty times and rest periods, in which case the Carrier will provide notice to Amazon of the specific change in applicable Law and supporting data and documentation that must be reasonably acceptable to Amazon);

2.5.3 All maintenance for the Aircraft that is not Heavy Maintenance and coordination and oversight of the scheduling, induction, maintenance provider management, and return to service of Aircraft in connection with all maintenance;

2.5.4 Aircraft hull and liability insurance and other insurance in accordance with the Insurance Requirements;

2.5.5 Dispatch, flight planning, and flight-following services, including ARINC or other radio communications services;

2.5.6 In-flight communications;

2.5.7 Exterior cleaning of the Aircraft;

2.5.8 Spare parts, including engine spare parts, avionics, rotables, expendables, tires, brakes, and accessory items (including transportation costs) to the extent that the spare parts are not otherwise subject to a separate agreement between the Parties or the responsibility of Amazon under Section 2.6.11, except that the Carrier may transport onboard each Aircraft, without charge: (a) a fly-away kit; and (b) aircraft parts and materials for the Aircraft on a reasonable, space-available basis;

2.5.9 All administrative and overhead services of the Carrier, including with respect to the provision of the authorizations, permits, and approvals subject to Section 2.6.2;

2.5.10 All facilities necessary for the provision of the Services;

2.5.11 All existing ground equipment, including GPUs, towing/pushback equipment and air start units that are owned by Sun Country or a Sun Country Provider and located at the locations identified in the Flight Schedule, except that Amazon will be responsible for the operation, maintenance, and repair of such equipment to the extent that: (a) such equipment is provided by Sun Country or a Sun Country Provider for Amazon's exclusive use; and (b) Amazon's responsibilities, if any, are expressly provided for under a Work Order, as described in Section 2.8.1; and

2.5.12 Maintenance Fuel.

2.6 Reimbursable Expenses. Except to the extent provided in accordance with Section 2.5, a Work Order, or this Section 2.6, and without limiting its obligations under this Agreement, Sun Country or the relevant Sun Country Provider will provide or cause to be provided the Personnel, Services, equipment, and other items set forth in this Section 2.6, subject to reimbursement by Amazon to Sun Country or the relevant Sun Country Provider (as applicable) of the reasonable, documented out of pocket costs actually incurred and paid, directly or indirectly, by Sun Country or the Sun Country Provider to a third party that is not Sun Country or one of its Affiliates, which will be included in invoices provided in accordance with Exhibit D:

2.6.1 Aircraft fuel (including taxes and environmental assessments, but excluding Maintenance Fuel and net of any fuel tax credits received by Sun Country or a Sun Country Provider) for operations conducted under this Agreement, subject to the requirements of Section 2.7;

2.6.2 Enroute fees, air traffic control fees, navigational fees, and airport charges (slot application fees, ramp fees, landing/departure fees);

2.6.3 Aircraft handling charges (inclusive of any airport concession costs), including with respect to pushbacks, marshaling, lavatory, water, cleaning of cargo compartments, use of GPU, air start units, steps, and towing;

2.6.4 Deicing fluid and deicing services;

2.6.5 Legal fees arising directly from the assignment, modification, or restructuring of an Aircraft Sublease;

2.6.6 Customs fees, permits, duties, and import/export fees;

2.6.7 All costs associated with or resulting from diversions due to adverse weather or leaking, smoking, or damaged cargo to the extent tendered by Amazon in such condition;

2.6.8 Positioning or de-positioning of the Aircraft for schedule changes not included in the Flight Schedule or other non-scheduled moves made at Amazon's request, as well as initial positioning of an Aircraft at the commencement of a Carrier Work Order and final de-positioning of an Aircraft subject to a terminated Carrier Work Order;

2.6.9 Noise and emission taxes, fees, and assessments not within the reasonable control of the Carrier and arising solely and directly as a result of Services performed under a Carrier Work Order;

2.6.10 Rent and any other amounts payable by the Carrier to ASI (or one of its Affiliates) under the Aircraft Sublease for the Aircraft subject to the corresponding Carrier Work Order, except that the Parties may elect to offset such amounts against those payable by Amazon to the Carrier so that no cash settlement is necessary;

2.6.11 Heavy Maintenance (to the extent paid by Carrier), including Spare Aircraft coverage and the provision of temporary spare engines, APUs and landing gear during periods of Heavy Maintenance as Amazon deems necessary as well as the provision of aircraft maintenance technicians on flights as described in [Section 2.21](#); and

2.6.12 FAA Airworthiness Directives required to be performed by Sun Country under an Aircraft Sublease and completed with:  
(a) recurring corrective action; or (b) terminating action, that requires modification of the Aircraft.

Sun Country will notify Amazon of its internal departments, Sun Country Providers, or third party subcontractors, responsible for performance of Services and provision of assets under this [Section 2.6](#), including reasonably requested details regarding those arrangements and operations. Sun Country will use, and will cause the Sun Country Providers to use, all commercially reasonable efforts to minimize costs and expenses pursuant to which Amazon has a direct or indirect reimbursement obligation under this Agreement.

## 2.7 Fuel.

2.7.1 Fuel Purchasing. Sun Country will purchase aircraft fuel and into-plane services from on-field fuel suppliers, distributors and into-plane providers to support the Services provided by the Carriers pursuant to the Agreement. Sun Country will facilitate the establishment and maintenance of agreements and customer accounts between the Carriers and fuel suppliers, distributors and into-plane providers that are qualified by the Carriers at such locations and will arrange for the purchase of aircraft fuel and into-plane services in conjunction with the departure times and days specified in the Flight Schedule. Sun Country will cause or arrange for the fuel suppliers, distributors and into-plane providers to invoice the Carriers directly for aircraft fuel and into-plane services. Notwithstanding the foregoing, Amazon may, by providing written notice to Sun Country, elect to purchase fuel for the Aircraft at one or more locations. The Parties acknowledge and agree that any fuel provided to a Carrier by Amazon is provided "as is" and without warranty of any kind, including the warranties of merchantability and fitness for a particular purpose, by, through or under Amazon, and that no warranties by, through or under Amazon will be implied by Law, provided, however, that the Carrier will have the right to approve any fuel supplier selected by Amazon (such approval not to be unreasonably conditioned, delayed, or withheld).

2.7.2 Fuel Reconciliation. Each month each Carrier will prepare a fuel reconciliation log (with copies of the aircraft log book as support) on a weekly basis that will reflect the actual fuel used by the Aircraft in the provision of the Services, which Sun Country will use to prepare invoices for fuel reimbursement under Exhibit D to this Agreement, as applicable. Sun Country will also promptly provide a copy of the fuel reconciliation log to Amazon upon request. When an Aircraft enters service for Amazon under this Agreement (*e.g.*, because it replaces or substitutes for another Aircraft, permanently or temporarily), or when an Aircraft leaves Amazon's service under this Agreement (*e.g.*, because it is replaced, or because it was only temporarily substituting for another Aircraft) either Amazon or Sun Country will reimburse the other for the cost of fuel in accordance with the following provisions of this Section 2.7 but also subject to Section 2.11.1 (Substitute Aircraft), Section 2.11.2 (Spare Aircraft), and Section 2.11.3 (Network Spares). When an Aircraft begins being utilized in the performance of Services under a Carrier Work Order, Amazon will reimburse Sun Country for the cost of fuel on board the Aircraft prior to its first departure flight in the provision of such Services. The per gallon fuel price for the above calculations will be the price per gallon paid at the last refuel of the Aircraft.

## 2.8 Ground Handling; ULDs.

2.8.1 Ground Handling Functions Provided by Amazon; Sun Country Provision of Services by Contract with Sun Country Providers. Amazon will be responsible for providing, at its cost, all ground handling and cargo handling functions except as and to the extent provided by a Sun Country Provider under one or more separate Ground Services Work Orders, pursuant to which a Sun Country Provider will be bound by the provisions of this Agreement with respect to such Ground Services Work Orders and Sun Country will remain jointly and severally responsible



for the provision of Services notwithstanding the contracting of Services to the Sun Country Provider. Any such “Ground Services Work Order” will reflect the following: (a) mutually agreed pricing to be assessed on per turn basis; (b) a mutually agreed bonus/penalty structure based on key performance indicators; and (c) reimbursement by Amazon of rent, utilities, taxes, insurance, and other reasonable, documented, out of pocket costs directly incurred by Sun Country in providing the Ground Services (for clarity, such reimbursement will be on a pro rata basis for shared facilities). To the extent ground handling services are provided by Amazon through a subcontractor, the Carriers will enter into an IATA Standard Ground Handling Agreement with such subcontractor and Amazon (as the “Management Company,” (“SGHA”).

2.8.2 Personnel Training and Qualifications. Unless ground handling is being provided by a Sun Country Provider under a Ground Services Work Order as described in Section 2.8.1, Amazon will ensure and require that all Personnel performing such ground handling and cargo handling functions are fully trained and qualified, and that all required training and evaluations are current and documented, in accordance with the relevant the Carrier’s FAA-approved programs and, further, that all equipment employed in providing such functions is serviceable, as determined in accordance with applicable FAA requirements and the Carrier’s FAA-approved programs. For purposes of this Section 2.8.2, Amazon’s obligation to ensure compliance with applicable FAA requirements and the Carrier’s FAA-approved program will apply only to the extent the Carrier has provided a copy of such FAA-approved program and FAA requirements at least [\*\*\*] days in advance of Amazon performing any such functions to enable Amazon to timely train and meet such program and requirements. The Carrier will provide a copy of any program (or amendment) for which FAA approval is required at the same time such program (or amendment) is submitted to the FAA and will advise Amazon in writing immediately upon receipt of approval and provide a copy of the final approved program (or amendment) and any conditions attached to such approval.

2.8.3 Delegation of Security Functions. To the extent necessary for Amazon to fulfill its obligations under this Agreement or any Work Order, each Carrier will delegate to Amazon, and Amazon will accept the delegation of, the cargo security inspection functions mandated by the TSA, including as prescribed in the Full All-Cargo Aircraft Operator Standard Security Program and the Carrier’s FAA-approved programs (collectively, “Security Programs”), provided that the Carrier will have provided Amazon with written notice of the delegation and a copy of the Carrier’s Security Programs at least [\*\*\*] days’ prior to Amazon performing any such functions to enable Amazon to timely train and meet such program and standards. Amazon will prepare and maintain logs of any such inspections in accordance with and to the extent required by, the Security Program.

2.8.4 Amazon Personnel as Agents of the Carrier. Amazon and its Personnel are authorized to act as agents of the Carriers in connection with the issuance of airbills and other transportation documents, in the acceptance of materials and goods from shippers and in determining their suitability for air transportation and any other reasonably related matters. In such capacity, Amazon and its Personnel will be governed by and will act in compliance with the GOM, Security Programs, and applicable Law. Amazon's obligation to comply with the GOM and Security Programs (or any amendments to same) will apply only to the extent the Carrier has provided Amazon a copy of such GOM and Security Programs (or amendment, as applicable) at least [\*\*\*] days' prior to Amazon's obligation to comply to enable Amazon to timely train and meet such program and standards. Amazon and its Personnel will be authorized to act as an agent for each Carrier in determining whether to cause any materials or goods to be transported by the Carrier or to cause such materials or goods to be transported by any other air carrier on an interline or any other basis. Such authorization will include the power to complete and deliver interline manifests, airbills, or other required transportation documents. In such capacity, Amazon Personnel will meet or exceed the legal and regulatory requirements applicable to the Carrier in regard to employee training and qualifications for weight and balance, Hazardous Materials recognition, alcohol and drug testing, employee background checks, and similar matters, in accordance with applicable Laws for employees in safety sensitive positions.

2.8.5 Procedures Under the GOM. To the extent Amazon Personnel are performing the loading (including with respect to Hazardous Materials), weight and balance calculations, ramp operations, and fueling operations required by the FAA to be performed in connection with the ground handling functions, including the requirements under the GOM: (a) the Carrier will be entitled, upon [\*\*\*] Business Days' prior written notice to Amazon, to audit such employees, agents, and contractors as necessary to comply with FAA requirements; and (b) Amazon's Personnel will not become the employees of the Carrier as a consequence thereof, but will be acting as agents for the Carrier when performing such loading, weight and balance, ramp operations, and fueling operations or calculations. Any Personnel not qualified or capable of performing such work will be identified to Amazon by the Carrier within [\*\*\*] Business Days following any such audit, and if requested to do so by the Carrier, such Personnel will be promptly removed from doing such work.

2.8.6 Transportation of Hazardous Materials. Amazon will have the right to tender for transport on the Aircraft cargo of a dangerous, hazardous, or offensive nature if: (a) such cargo is properly identified, packed, marked, labeled, and placarded in accordance with applicable IATA and ICAO/FAA dangerous goods and hazardous materials regulations; (b) such transportation is in compliance with the GOM and all other applicable Laws; and (c) the Carrier is authorized by the FAA to carry such cargo.

2.8.7 Aircraft Payload; Limitations. The maximum cargo payload for each flight of the Aircraft will be in accordance with applicable FAA-approved Aircraft limits. The actual cargo payload capable of being carried on the Aircraft will be limited by either the weight or volume depending on which is exhausted first. Operating conditions or applicable FAA requirements may result in an increase or decrease in payload weight or volume limit.

2.8.8 Payload Reports. The Carriers will provide to Amazon: (a) preliminary maximum payload figures for each flight at least [\*\*\*] hours prior to the scheduled departure time set forth in the Flight Schedule, and (b) final maximum payload figures for each flight at least [\*\*\*] hours prior to the scheduled departure time set forth in the Flight Schedule. This information will be communicated to Amazon operations via email at the email address provided by Amazon and updated from time to time, and will use the most recent aviation forecasts for the scheduled departure time of the flight.

2.8.9 Tender of Cargo. Cargo will be tendered by Amazon or any Amazon designee under the Carrier's air waybills, prepared, labeled, securely packaged, and ready for transportation by the Aircraft along with the: (a) shipment destination; (b) name and address of the recipient; (c) nature of the cargo; (d) particular marks/numbers used; (e) weight, quantity, volume, and dimensions of cargo; and (f) any special circumstances or handling information, and otherwise in accordance with all applicable Laws.

2.8.10 Refusal to Transport. The Carrier may reasonably refuse to transport any cargo that: (a) cannot be transported in accordance with Sections 2.8.6, 2.8.7, or 2.8.9; or (b) would otherwise reasonably endanger the safety of flight.

2.8.11 USPS Cargo. Amazon has entered into an agreement and may enter into additional agreements (the "USPS Prime Contracts") with the United States Postal Service ("USPS") for the air transportation of USPS cargo on flights performed by Carriers under this Agreement. In connection with same, Sun Country has reviewed and agrees that the Sun Country Providers and their respective Personnel will comply, to the extent applicable for the Services being performed by Sun Country, with all of the requirements provided in this Agreement, including those listed in Exhibit G.

2.9 Training Provided by the Carrier. Each Carrier will, at the request of Amazon upon [\*\*\*] Business Days' written notice to such Carrier, provide, or cause to be provided not more than once each quarter during any Contract Year, training classes to qualify Amazon trainers to provide training to Amazon Personnel engaged in, providing security, ground handling, and cargo handling functions in connection with the Services provided by the Carrier, including training in the Carrier's Security Programs, GOM, and other FAA-approved programs (collectively, "Training"). The Training will be held at a mutually agreed location and be provided at no charge to Amazon Personnel, except that if the Training is provided somewhere besides Eagan, Minnesota, Amazon will be responsible for the reasonable and documented travel expenses of Carrier Personnel that are required to provide the Training in accordance with Amazon's standard travel policies.

## 2.10 Schedule; Modifications.

2.10.1 Flight Schedule. The Parties will mutually agree on the initial flight schedule prior to the Services Commencement Date for the first Committed Aircraft (as subsequently amended in accordance with Section 2.10.2, the “Flight Schedule”). The Parties agree that the Flight Schedule for the calendar month of [\*\*\*] will not exceed an average of [\*\*\*] per Aircraft then subject to a Carrier Work Order.

2.10.2 Amendments to the Flight Schedule. Subject to the Scheduling Constraints, the Flight Schedule may be amended or replaced by Amazon in its sole discretion at any time. Amazon will provide the relevant Carrier with: (a) [\*\*\*] days’ prior written notice of a proposed amendment to the Flight Schedule that does not require the opening of a new station where Sun Country does not have current flight operations or an increase of greater than [\*\*\*] percent in the number of Flight Crews (in the aggregate) assigned to the then current Flight Schedule or two Flight Crews, whichever is greater; (b) [\*\*\*] days’ prior written notice of a proposed amendment to the Flight Schedule that requires the opening of a new station where Sun Country does not have current flight operation; and (c) [\*\*\*] days’ prior written notice of a proposed amendment to the Flight Schedule that requires an increase of greater than [\*\*\*] percent in the number of Flight Crews (in the aggregate) assigned to the then current Flight Schedule or [\*\*\*] Flight Crews, whichever is greater. Such amendments will be incorporated into a revised Flight Schedule beginning [\*\*\*] days (in the case of clause (a)), [\*\*\*] days (in the case of clause (b)), or [\*\*\*] days (in the case of clause (c)) after receipt of such notice from Amazon, as applicable, except that to the extent that the Carrier does not begin operating according to the amended Flight Schedule at that time, Amazon will be credited \$[\*\*\*] for each day of delay on the next Monthly Invoice. Upon Amazon’s request, the Carrier will provide Amazon data and documentation supporting the number of required Flight Crews that must be acceptable to Amazon (such acceptance not to be unreasonably withheld). A Carrier may only reject or request a change to Amazon’s proposed amendments to the Flight Schedule on the basis that such proposed amendments do not comply with Scheduling Constraints, and, simultaneously with any such rejection or request for change, such Carrier must provide a reasonably detailed written justification for such rejection or request for change, including references to the specific language of the Carrier’s collective bargaining agreement with its flight crewmembers and/or the applicable FAA regulations and supporting data and documentation, that must be acceptable to Amazon (such acceptance not to be unreasonably withheld). The applicable Carrier must notify Amazon if it determines that any Flight Schedule is outside of the above parameters within [\*\*\*] Business Days of receipt of the Flight Schedule from Amazon, otherwise Carrier will be deemed to have accepted the Flight Schedule and waived any notice or other requirements hereunder. Changes to the Flight Schedule will be documented in sequentially numbered versions signed by Amazon and the Carrier(s). For any substantial Flight Schedule amendments in concurrence with a new network execution plan (estimated to be approximately [\*\*\*] times annually) Amazon will endeavor to provide Sun Country: (y) a copy of the preliminary flight schedule at least [\*\*\*] days in advance of the effective date of such flight schedule for the purpose of soliciting Carrier feedback on maintenance bases, block times, crew availability, and other relevant factors; and (z) additional opportunities to review same in the event of any significant changes. In both circumstances, Carriers will provide their feedback as soon as

reasonably possible. For clarity, notwithstanding the foregoing, the final Flight Schedule (whether amended in concurrence with a network execution plan or otherwise) will be subject to the requirements otherwise provided in this Section 2.10.2. Provided that Amazon does not then have a right to terminate this Agreement or any individual Work Orders based on Sun Country's Arrival Performance pursuant to Section 4.2.2, if, in the time period that is less than [\*\*\*] but more than [\*\*\*] in advance of the effective date of a new Flight Schedule, Amazon: (a) [\*\*\*]; and (b) [\*\*\*], then Amazon will reimburse Sun Country [\*\*\*] ("Change Fee") in accordance with Section 2.6, except that Amazon will not be required to pay Sun Country a Change Fee until [\*\*\*] in any Contract Year.

2.10.3 Temporary Changes to the Flight Schedule. Amazon may, subject to the Scheduling Constraints, request temporary changes in the departure time, the scheduled air routes, the frequency, Availability Windows, or the destinations or stops outlined in the Flight Schedule without amending the Flight Schedule (such a change without amendment to the Flight Schedule a "Temporary Schedule Change"). Amazon will provide the relevant Carrier with prior written notice of each Temporary Schedule Change (including via email) and the Carrier will implement each Temporary Schedule Change as soon as reasonably practicable and will minimize any additional associated costs. The Carrier will promptly provide Amazon with its estimate of incremental costs that would arise from each proposed Temporary Schedule Change and, if Amazon determines to proceed with such Temporary Schedule Change after receiving such estimate, Amazon will reimburse Sun Country for any incremental reasonable, documented out of pocket costs actually incurred by the Carrier arising from a Temporary Schedule Change in accordance with Section 2.6 and Exhibit D of this Agreement, up to the amount of such estimate. For clarity, any change included in the Flight Schedule pursuant to Section 2.10.2 will not be considered a Temporary Schedule Change under this Section 2.10.3 regardless as to the duration of such change.

2.10.4 Unscheduled Stops. The Carriers will make any Unscheduled Stops, subject to: (a) the Flight Operations Requirements; (b) the requirements of the relevant Carrier's collective bargaining agreement; (c) or applicable Law. Amazon will reimburse Sun Country for any incremental reasonable, documented out of pocket costs actually incurred by such Carrier arising from an Unscheduled Stop in accordance with Section 2.6 and Exhibit D of this Agreement.

## 2.11 Aircraft Operations.

2.11.1 Substitute Aircraft. The Carriers may substitute for operation of the Flight Schedule any aircraft having the aggregate capacity and other performance characteristics reasonably necessary to handle the payload and timing requirements for such flights ("Substitute Aircraft"), except that: (a) such substitution will not interfere with performance of Services in compliance with this Agreement and the corresponding Carrier Work Order; (b) the Carriers will only provide such a Substitute Aircraft if Amazon approves of the substitution in writing (which will not be unreasonably withheld, delayed, or conditioned); and (c) the Carriers will reimburse Amazon for any landing fees or other costs (including incremental fuel burn, ferry flights and Variable Charges) in excess of those that Amazon would have incurred under Section 2.6 had the flights been operated with the affected Aircraft.

2.11.2 Spare Aircraft. The Carriers may provide and operate one or more spare aircraft having the aggregate capacity and other performance characteristics reasonably necessary to handle the payload, flight schedule, and timing requirements for Carrier's flights with the Aircraft ("Spare Aircraft") in substitution for an Aircraft that is unavailable to perform the Services under the Flight Schedule due to a Carrier Delay. In addition, each Carrier may make one or more Spare Aircraft available at Amazon's request ("Amazon Spare Request"): (a) to perform flights that are not part of the Flight Schedule; or (b) to substitute for an Aircraft that is unavailable due to a reason that is not attributable to a Carrier Delay. Amazon will compensate the relevant Carrier at an agreed upon rate per day, or portion thereof, for the use of a Boeing 737 model Spare Aircraft (by payment to Sun Country) when the Carrier provides a Spare Aircraft at Amazon's request. In the event that an Aircraft is unavailable due to a Carrier Delay and the Carrier provides a Spare Aircraft, the Carrier will reimburse Amazon for any landing fees, or other costs (including incremental fuel burn, ferry flights and Variable Charges) in excess of those that Amazon would have incurred under Section 2.6 had the flights been operated with the affected Aircraft. In the event that a Spare Aircraft is unavailable to substitute for an Aircraft that is unavailable due to a Carrier Delay, then the resulting cancellation or delay will be factored into the calculation of Arrival Performance for the relevant period, except that such availability will not be taken into account to the extent that a Spare Aircraft is unavailable because it has already been provided to support an Amazon Spare Request. Except for the cost reimbursement and fee described in this Section 2.11.2, a Carrier's performance of the Services utilizing a Spare Aircraft in accordance with this Section will otherwise be subject to the terms and conditions of this Agreement. For clarity, the Parties acknowledge that Sun Country does not have a Spare Aircraft available as of the Effective Date.

2.11.3 Network Spares. Amazon may, in its sole discretion, designate one or more Aircraft on the Flight Schedule to be available to provide backup or supplementary lift in support of Amazon's network (each, a "Network Spare") except that Amazon may not be able to designate an Aircraft as a Network Spare until [\*\*\*]. Sun Country, at its sole cost and expense, may use a Network Spare as a Substitute Aircraft or Spare Aircraft except that: (a) such use will not interfere with the performance of Services in compliance with this Agreement; (b) Sun Country will only use a Network Spare as a Substitute Aircraft or Spare Aircraft if an Amazon Leadership Representative provides prior written consent (which may be granted or withheld in Amazon's sole discretion); (c) Sun Country will reimburse Amazon for any landing fees, or other costs (including incremental fuel burn, ferry flights and Variable Charges) in excess of those that Amazon would have incurred under Section 2.6 had the flights been operated by the affected Aircraft; and (d) Section 2.11.1 (Substitute Aircraft) and Section 2.11.2 (Spare Aircraft) will otherwise apply to Sun Country's use of a Network Spare as a Substitute Aircraft or a Spare Aircraft. If a Network Spare is not available during an Availability Window due to a Carrier Delay (for clarity, not including a situation in which such Network Spare is unavailable because it is being used by a Carrier as a Spare Aircraft to support an Amazon Spare Request), then, for each day that such Network Spare remains unavailable, Sun Country will pay to Amazon an amount equal to [\*\*\*] of the Fixed Monthly Charge for the Network Spare.

2.11.4 Intermediate Landings; Flight Disruptions. If a Carrier determines that an intermediate landing is necessary due to Force Majeure, the Carrier will invoice and Amazon will reimburse reasonable and documented additional costs incurred by the Carrier (including added Variable Charges, fuel, landing, maintenance turn costs, aircraft handling costs, and ground handling costs) in accordance with Section 2.6 and Exhibit D of this Agreement. Any additional costs with respect to such Force Majeure intermediate landings or arising from a mechanical problem or technical failure of the Aircraft or any failure to meet the Compliance Requirements (including a diversion of the Aircraft or return of the Aircraft to the origin station) will be for the account of the Carrier, in which case Amazon will pay only the Variable Charges and fuel charges as if the flight had been non-stop and according to the Flight Schedule so long as the flight is completed within [\*\*\*] hours of the arrival time set forth in the Flight Schedule, and the Carrier will pay the added fuel charges, landing fees, positioning and repositioning expenses, and other costs associated with such intermediate landing, except that the Carrier will be responsible for all Variable Charges and fuel charges to the extent that the flight is not completed within [\*\*\*] hours of the arrival time set forth in the Flight Schedule. For clarity, Amazon will not be responsible for any Variable Charges with respect to Aircraft returning to the ramp before take-off caused by act or omission of the relevant Carrier, including mechanical problems or technical failure of the Aircraft or any failure to meet the Compliance Requirements and all other costs such as Aircraft handling charges arising from such circumstances will be borne by the Carrier.

2.12 Operations for Third Parties. Until such time [\*\*\*], the Carriers may use the Aircraft to provide air cargo transportation services to third parties so long as: (a) such usage does not interfere in any material respect with the Carrier's performance of the Services; (b) the Carrier is not then in default under this Agreement; and (c) an Amazon Leadership Representative provides prior written consent (which may be granted or withheld in Amazon's sole discretion). If a Carrier arranges and provides air cargo transportation services to or for third parties using the Aircraft pursuant to a charter, wet lease, or any other arrangement (such services hereinafter referred to as "Supplemental Flying"), then the Carrier will pay Amazon an agreed upon rate per day, or portion thereof, that the Carrier uses a Boeing 737-800 model Aircraft for Supplemental Flying, which fee will be payable as described in Section 2.12.1. Except as set forth herein, all revenue from such Supplemental Flying will inure to the benefit of the relevant Carrier. The Carrier is solely responsible for all of its operating costs with respect to or associated with Supplemental Flying. For clarity, Supplemental Flying only includes air transportation services that are arranged solely by the Carrier and does not include any of the flights referenced in Section 2.12.2.

2.12.1 On the final invoice for each month provided in accordance with the invoicing and payment provisions of Exhibit D to this Agreement, Sun Country will provide to Amazon a detailed statement setting forth the utilization of any Aircraft for Supplemental Flying during the prior month and a credit in the amount of the fees owing to Amazon related to such utilization. For clarity, the amounts payable to Amazon under this Section 2.12 will not be prorated and will apply regardless as to the portion of the day an Aircraft is used for Supplemental Flying.

2.12.2 Amazon may, from time to time, present the Carriers with potential opportunities to charter the Aircraft to third parties (“Charters”). In such event, Amazon may, in its sole discretion, act as an agent of either the Carrier or such third party Charter customer in accordance with applicable Law. The Carrier and Amazon will negotiate in good faith regarding the allocation of the percentage of the total Charter price to be paid by the third party Charter customer that will be shared between Amazon and the Carrier. For clarity: (a) the third party Charter customer will be responsible in all cases for compliance with all applicable Laws and contract requirements; (b) Amazon will have no responsibility to provide, procure, or coordinate any services in relation to the Charters whatsoever; and (c) the Carrier will, in its commercially reasonable discretion, determine in each case whether to: (i) accept such Charters; (ii) or to accommodate ad hoc flights for USPS or with respect to which Amazon is acting as an indirect air carrier that are not part of the Flight Schedule, in each case based on the availability of supporting resources (excluding the Aircraft). For clarity, clause (c)(ii) does not apply to any scheduled flights that are included on the Flight Schedule.

2.13 Force Majeure. The obligations of a Party under any Work Order may be suspended during the period and to the extent that such Party is prevented from complying with such obligations as a direct result of any of the following causes (in each case, only to the extent beyond such Party’s reasonable control): severe weather preventing flight operations, damage or destruction of flight equipment, riots or civil commotions, military emergency, terrorism, war or hazards, or damages incident to a state of war, strikes, lockouts, industrial disturbances, or other labor disputes, but not including Carrier Delays (each, a “Force Majeure”); except that in each case nothing in this Section 2.13 will relieve a Party of any obligation due to an event that was reasonably foreseeable, whose material adverse effects could reasonably have been avoided or that otherwise could have reasonably been prevented by such Party, except that a Party’s obligations will be suspended only to the extent that: (a) as soon as reasonably possible (but in any event within [\*\*\*] hours of occurrence of the event) such affected Party gives written notice of suspension to the other Party describing the time, date, extent and cause of the Force Majeure, and remediation plan for such suspension with reasonable detail; and (b) as soon as reasonably possible (but in any event within [\*\*\*] days of occurrence of such event) such affected Party submits adequate evidence of the occurrence of such Force Majeure (which may be in the form of newspaper articles, government notices, insurance reports, sworn statements, and other evidence that objectively documents the severity of the event) that supports the material adverse effect such identified Force Majeure has had on the Party’s ability to fulfill its obligations under this Agreement. If a Force Majeure affects Sun Country’s or a Sun Country Provider’s ability to provide all or part of the Services required under this Agreement, Amazon will have the right, but not the obligation, to arrange for another party to provide such Services until such time as the Force Majeure can be cured and for a reasonable period thereafter; provided that except as otherwise provided for herein, Sun Country or such Sun Country Provider will be reinstated as soon as is reasonable under the circumstances. The daily portion of the Fixed Monthly Charge will not be payable for any day that a Carrier’s obligations are suspended under Force Majeure (other than the day of a Force Majeure Event due solely to severe weather preventing flight operations) and the Fixed Monthly Charge will be prorated as applicable for any partial months of such suspension. Any Party whose obligations are suspended under this Agreement will use commercially reasonable efforts to minimize the impact of the suspension and resume the performance of its obligations as soon as reasonably possible. If Sun Country’s or a Sun Country Provider’s obligations are suspended for more than [\*\*\*] days out of any [\*\*\*]-day period under this Section 2.13, Amazon may thereafter immediately terminate the affected Work Order(s) by giving notice of such termination to Sun Country without paying any termination fee or other charges.



2.14 Unavailability. In the event that the non-availability of the Aircraft due to a Carrier Delay will result in a delay of [\*\*\*] hours or more from the scheduled arrival time set forth in the Flight Schedule for a flight at its original point of departure, then the relevant Carrier will promptly notify Amazon of such delay and Amazon will be entitled to determine, in its sole discretion (within [\*\*\*] hours of being so notified by the Carrier), whether to proceed with the flight as soon as reasonably practicable or to cancel the flight. In either event, Amazon will be entitled to an invoice credit against the Fixed Monthly Charge as follows:

2.14.1 \$[\*\*\*] if the Aircraft is operated but arrives more than [\*\*\*] hours but less than [\*\*\*] hours late at one or more of its scheduled destinations on the Flight Schedule for that day; or

2.14.2 \$[\*\*\*] if either: (a) the Aircraft is operated but arrives [\*\*\*] hours or more late at one or more of its scheduled destinations on the Flight Schedule for that day; or (b) Amazon elects to cancel the flight.

Any credit against the Fixed Monthly Charge will apply to each of the inbound and outbound flights of the Aircraft on a given day, to the extent set forth on the Flight Schedule, such that the total credit due to Amazon for a given day will be the sum of the above credit amounts incurred on each of such inbound and outbound flights that day. For clarity, only one credit in the amount set forth above will apply to each inbound and outbound flight even if the Aircraft arrives late at more than one scheduled destination on the Flight Schedule for that day. For purposes of this Section 2.14, “unavailability of the Aircraft” includes the Aircraft being unavailable due to a Carrier Delay and the lateness of the Aircraft will be calculated in the same manner as provided for in Section 4.2 of Exhibit C.

2.15 Destruction or Casualty Loss of Aircraft. Notwithstanding anything contrary contained in this Agreement, if an Aircraft is destroyed or otherwise suffers a casualty occurrence that would constitute a total loss or a constructive total loss under the terms of the hull insurance required by Section 9.1.4 of this Agreement with respect to such Aircraft, then the affected Carrier Work Order will terminate with respect to such Aircraft and no Party will have any further obligation or liability to the other with respect to such Aircraft except that Sun Country will use commercially reasonable efforts to coordinate alternate lift arrangements to cover any network capacity lost. For clarity, Amazon will have no obligation to pay any Carriers any fee, charge, compensation, damages, or other amount upon the expiration or termination of such Carrier Work Order, other than preexisting payment obligations then due and owing, and obligations for Services that have already been performed by the Carrier but that have not been billed in accordance with the affected Carrier Work Order and Exhibit D.

2.16 Sustainability; Fuel Conservation. Sun Country, the applicable Sun Country Providers and Amazon agree to pursue fuel conservation and sustainability efforts as follows:

2.16.1 Fuel Optimization. Sun Country and the applicable Sun Country Providers will implement the Fuel Optimization Program throughout the term of this Agreement, except that the Parties will work together to develop reasonable plans and programs to maximize each Carrier’s fuel efficiency and minimize Amazon’s fuel cost in the Carrier’s operations for Amazon under this Agreement.

2.16.2 Fuel Tankering. Sun Country and the applicable Sun Country Providers will use commercially reasonable efforts to maximize fuel purchases at optimized locations based on the Flight Schedule in order to avoid paying a higher price at down-line locations.

2.16.3 Fuel Burn Optimization – In-flight Operations. Each Carrier will use best efforts to develop, implement, and maintain operating policies that minimize excessive fuel burns while in flight. Without limiting the foregoing, the Carriers will (to the extent in compliance with applicable Law): (a) create and implement a landing fuel policy that will set a specific target for reserve fuel upon arrival at destination and only deviate from that policy for specific enumerated reasons, including weather; (b) create and implement guidance for pilots to minimize flap usage on approach and reverse thrust on landing to the extent consistent with safe operations; (c) adjust the fuel planning methodology to round fuel to units of 100 lbs.; and (d) review specific city pair taxi times to more accurately estimate fuel required for specific city pairs.

2.16.4 Third Party Audit. By no later than the anniversary of each Contract Year, Sun Country and the Sun Country Providers, at Amazon's election and at its sole cost and expense, will undergo a third party audit of the fuel conservation practices described in this Section 2.16 to be performed by a recognized industry auditor that is reasonably acceptable to Sun Country. Amazon will promptly provide Sun Country with a copy of the results of such audit. The Carriers will cooperate with Amazon in implementing procedures that will result in greater overall fuel efficiency, including using all commercially reasonable efforts to implement the recommendations of such audit in accordance with applicable Law.

2.16.5 Sustainability. Each Carrier will use commercially reasonable efforts to minimize carbon emissions and participate in other sustainability efforts as may be requested by Amazon, taking into account the Aircraft, the Flight Schedule, and the Fuel Optimization Program described in this Section 2.16.

2.17 Reports, Audits and Record Retention. Sun Country will provide to Amazon Reports and Electronic Communications in accordance with the requirements set forth in Exhibit D at no additional charge. Sun Country and each Sun Country Provider will keep true and accurate books and records relating to this Agreement and the Services (collectively "Records") in accordance with generally accepted accounting principles during the term of this Agreement and for a rolling period of [\*\*\*] years thereafter. At Amazon's request during the term of this Agreement and for [\*\*\*] years thereafter, Sun Country and each Sun Country Provider will: (a) enable Amazon and any designee, at its cost and expense, to reasonably conduct a reasonable invoicing, service, and performance audit no more than [\*\*\*] per calendar year (except during the occurrence of any Event of Default by Sun Country or a Sun Country Provider, in which event Amazon's audit rights will not be limited) to determine if such Party is meeting its obligations under this Agreement, including providing access to and electronic copies of all relevant Records in a satisfactory mode and format that enables Amazon and its designee to conduct such audit; and (b) permit Amazon and any designee, at its cost

and expense, to conduct no more than [\*\*\*] per calendar year (except during the occurrence of any Event of Default by Sun Country or a Sun Country Provider, in which event Amazon's audit rights will not be limited) a reasonable on-site inspection of the facilities, processes, systems, and working conditions applicable to the provision of the Services to determine if such Party is in compliance with this Agreement, including, specifically the Compliance Requirements. To the extent that any such amount is not subject to a good faith dispute, Sun Country will reimburse Amazon for the full amount of any overcharge identified in the audit within [\*\*\*] days from receipt of the audit results. If an audit identifies an overcharge by Sun Country or any Sun Country Provider, in the aggregate, for the period audited in excess of [\*\*\*] of the total expenditure under this Agreement for the period audited, Sun Country will also promptly reimburse Amazon for all reasonable and documented out of pocket expenses including the cost associated with the use of third parties to perform such audit.

2.18 Access to Information Technology Systems. The Carriers will provide Amazon with real-time read-only access to information technology systems relating to the maintenance and operation of the Aircraft with (to the extent available) the following information: (a) graphical flight schedule interface including planned and current flight schedules; (b) crew duty times; (c) ramp status; (d) weight and balance; (e) Aircraft maintenance data, including current maintenance status, Flight Crew and maintenance log pages, and ACARS data, in each case including data extraction capability; and (f) maximum payload figures. The Carriers will be responsible to ensure that the software for such information technology systems remains current and up to date.

2.19 Designated Point of Contact. The Sun Country Providers will provide one designated senior management point of contact (for clarity, in addition to the availability of the Presidents of each Sun Country Provider and each Carrier's technical operations team to their Amazon counterparts during normal business hours) on all shifts that: (a) is fully apprised of and responsible for all aspects of the Amazon operation; (b) has immediate access to all relevant information and the ability to make real-time decisions on behalf of the Sun Country Providers; and (c) is available for resolution of any operational matters. At such time as Sun Country is providing Services for [\*\*\*] or more Aircraft, the aforementioned point of contact will be fully dedicated to Amazon's operations. The Sun Country Providers will also provide senior management points of contact to whom Amazon may reach out directly for an escalation in each of the following areas: (w) ground handling operations (e.g., set-up, deicing, fueling, lavatory, etc.); (x) scheduling and planning; (y) systems operations; and (z) regulatory compliance.

2.20 Continuous Improvement. Each Carrier will meet with Amazon on a quarterly basis in Seattle to review operations under this Agreement and propose synergies, solutions, and ideas to lower costs and increase operational efficiency. Each Carrier will provide: (a) financial and operational reports in form and substance reasonably acceptable to the Parties; and (b) other information related to the Services that may be reasonably requested by Amazon no less than [\*\*\*] Business Days in advance of each such meeting.

2.21 Aircraft Maintenance Technician. The Carriers will provide, at Amazon's request, an appropriately certified and rated aircraft maintenance technician as a flight mechanic on each flight operated by the applicable Carrier for the first [\*\*\*] days (extended to [\*\*\*] days if any material service, reliability, or other issues are noted during the initial [\*\*\*] days) after the entry into service of an Aircraft under this Agreement that is new or freshly converted. Amazon will pay to Carrier a per day rate of \$[\*\*\*] for each day that an aircraft maintenance technician is provided by a Carrier under this Section 2.21.

2.22 IATA BSP; Electronic Data Interchange. The Sun Country Providers will implement Electronic Data Interchange invoicing within [\*\*\*] days of Amazon's written request and will implement IATA's Billing and Settlements Program (BSP) or other similar platform if mutually agreed.

2.23 Maintenance Process. Sun Country will be responsible for all technical aspects of scheduled and unscheduled shop level maintenance including, but not limited to, scheduling, management workscope development and technical (engineering) specifications. Such specifications and worksopes will be provided to Amazon for review and approval (such approval not to be unreasonably withheld). All Heavy Maintenance will be performed by an FAA-approved maintenance provider that, to the extent it is the responsibility of Amazon under this Agreement, will be selected and contracted directly by Amazon. All other maintenance will be performed by an FAA-approved maintenance provider to be selected by Sun Country and reasonably acceptable to Amazon (such approval not to be unreasonably withheld).

### 3. PAYMENT

3.1 Fixed Monthly Charge; Variable Charges. Amazon will pay to Sun Country each month (or portion thereof) the Fixed Monthly Charge specified in the Price Schedule for each Aircraft during the term of each Carrier Work Order (the "Carrier Work Order Term"). In addition, subject to the provisions of any applicable Work Order, Amazon will pay to Sun Country the Variable Charge Per Block Hour for each Block Hour (or portion thereof) flown by an Aircraft during such month and the Variable Charge Per Cycle for each Flight Cycle flown by an Aircraft during such month. Amazon will not have any separate payment obligation to any Sun Country Provider with respect to the performance of the Services other than that specified in this Agreement. Neither Sun Country nor any Sun Country Provider is entitled to other fees, costs, accessorial, additional expenses, charges, surcharges, tariffs or other compensation or reimbursement for the Services other than as provided in this Agreement and the relevant Work Order. All pricing components in the Price Schedule [\*\*\*] will be subject to an annual increase of [\*\*\*] per Contract Year starting on December 13, 2020.

3.2 Startup Costs. Amazon will pay Sun Country \$[\*\*\*] towards start-up costs to be used in Sun Country's sole discretion, including for: (a) pilot, dispatcher, mechanic, and ground handler training; (b) IT integration; (c) flight simulator time; (d) legal and consulting support; (e) technical due diligence; (f) manual development; and (g) hiring in advance of operations. Such amount will be paid by Amazon in [\*\*\*] installments[\*\*\*].

3.3 Payment for Cancellation of Flights. Except as otherwise provided in this Agreement, Amazon will pay the Fixed Monthly Charge without adjustment notwithstanding any cancellation of flights during the corresponding Work Order Term, except that Amazon will otherwise not be subject to any charges with respect to any cancelled flights.

3.4 Invoices and Payment. The terms of Exhibit D will govern the rights and obligations of the Parties with respect to invoices and payment and all other subject matter addressed therein.

#### 4. TERM AND TERMINATION

4.1 Term; Renewal Option. The term of this Agreement will begin as of the Effective Date and, unless earlier terminated in accordance with this Section 4, will continue until the Scheduled Termination Date. Amazon will have the option to renew this Agreement for [\*\*\*] additional [\*\*\*] terms in its sole discretion, subject to Amazon providing Sun Country with at least [\*\*\*] days' prior written notice before the expiration of the then-current term.

##### 4.2 Amazon Terminations.

4.2.1 Amazon may terminate this Agreement for convenience at any time by providing Sun Country with [\*\*\*] days' prior written notice, except that Amazon may not provide notice of its intent to terminate this Agreement during the first [\*\*\*] months after the Effective Date. In the event that Amazon terminates this Agreement for convenience, Amazon will pay Sun Country a termination fee of \$[\*\*\*] million per Aircraft that is then subject to a Carrier Work Order [\*\*\*] (the "Amazon Termination Fee").

4.2.2 Amazon may terminate this Agreement or any individual Work Orders at any time that the Carriers fail to maintain a collective Arrival Performance of at least [\*\*\*]% in either: (a) each of any [\*\*\*] consecutive months; or (b) each of any [\*\*\*] months (whether or not consecutive) within any trailing 12-month period, in either event occurring after [\*\*\*]. Any election under this Section 4.2.2 shall not require payment of an Amazon Termination Fee and such election shall be made no later than [\*\*\*] days following the last occurrence of such event. The sole and exclusive remedy in respect of the foregoing circumstances shall be termination pursuant to this Section 4.2.2.

4.3 Payment of Amazon Termination Fee. In the event of an Amazon termination for convenience pursuant to Section 4.2, Amazon will pay to Sun Country the Amazon Termination Fee on or before the date of termination of this Agreement, in addition to any other amounts due under this Agreement to Sun Country as of the date of termination (whether or not such amounts are yet invoiced or payable), and Amazon will have no further obligations or liabilities to Sun Country under this Agreement following such termination. The Amazon Termination Fee will be deemed liquidated damages and not a penalty. For clarity, any amounts due under this Agreement to Amazon as of the date of termination (whether or not such amounts are yet invoiced or payable) will remain due. The Amazon Termination Fee applies only in the case of the termination of this Agreement, and not the termination of one or more Work Orders, however, in the event that Amazon terminates enough Carrier Work Orders for convenience pursuant to Section 4.7(a) such that there are less than [\*\*\*] active Carrier Work Orders, Sun Country may deem this an Amazon termination for convenience by providing written notice to Amazon within [\*\*\*] days of Sun Country's receipt of Amazon's

most recent termination notice. If Sun Country provides such notice, this Agreement will terminate on the [\*\*\*] day after Amazon's receipt of such notice and Amazon will pay the applicable Amazon Termination Fee on or before such termination date. For clarity, the reduction in the number of any Carrier Work Orders due to Force Majeure or the total or constructive total loss of an Aircraft as described in Section 2.15 will not trigger Sun Country's right to deem such reduction an Amazon termination for convenience under this Section 4.3.

4.4 Sun Country Termination for Convenience. Sun Country may terminate this Agreement for its convenience at any time by providing Amazon with [\*\*\*] days' prior written notice, except that Sun Country may not provide notice of its intent to terminate this Agreement during the first [\*\*\*] months after the Effective Date. In the event that Sun Country terminates this Agreement for convenience, Sun Country will pay Amazon a termination fee of \$[\*\*\*] per Aircraft that is then subject to a Carrier Work Order. The termination fee will be paid on or before the date of termination of this Agreement, in addition to any other amounts due under this Agreement to Amazon as of the date of termination (whether or not such amounts are yet invoiced or payable), and Sun Country will have no further obligations or liabilities to Amazon under this Agreement following such termination. For clarity, any amounts due under this Agreement to Sun Country as of the date of termination (whether or not such amounts are yet invoiced or payable) will remain due. Following any termination under Section 4.2 or 4.4 and payment of any related termination fees (if any), neither Party will have any further obligation under this Agreement save for such obligations which arose prior to termination and those which expressly survive termination of this Agreement.

4.5 Events of Default; Remedies. The occurrence of any of the following events or conditions will constitute an event of default (each an "Event of Default"):

4.5.1 Sun Country or any Sun Country Provider materially violates any of the Compliance Requirements, Insurance Requirements, or any Carrier fails to maintain its Operating Authority;

4.5.2 Any Carrier operates an aircraft (for clarity, whether or not such aircraft is an Aircraft in connection with the Carrier's performance of the Services), involved in: (a) [\*\*\*] or more "aircraft accidents" involving a "serious injury" or "substantial damage" to the aircraft in a rolling 12-month period; or (b) an "aircraft accident" involving a "fatal injury;" in either case for which the affected Carrier was determined to be at fault (including, for clarity, in a preliminary report) by the NTSB or an equivalent aviation authority having jurisdiction over the matter (all terms in quotations in this Section 4.5.2 are as defined by the NTSB in 49 C.F.R. Part 830);

4.5.3 Sun Country or any Sun Country Provider is assessed or is subject to, by a FAA: (a) a single civil penalty or aggregate civil penalties in any 12-month period, including a compromise civil penalties, that exceed \$[\*\*\*] pursuant to a final agency order; or (b) an enforcement action that results in the revocation or suspension of a Carrier's Operating Authority (or the authority of such Sun Country Provider to provide the Services);

4.5.4 A Party's material breach or failure to observe or perform in any other material respect, as applicable, any representation, warranty, covenant, or agreement hereunder that has occurred and is continuing for [\*\*\*] days after receipt of written notice from the non-breaching Party identifying such material breach and notice of the intent to terminate if such material breach is not cured; provided that such period will be extended to [\*\*\*] days to the extent that: (a) the breach is capable of remedy (as determined by the non-breaching Party in its reasonable sole discretion); (b) the breaching Party is diligently pursuing such remedy; and (c) and there is no actual or reasonably likely material adverse effect on the breaching Party's provision of the Services;

4.5.5 If: (a) a Party commences a voluntary case under Title 11 of the United States Code or the corresponding provisions of any successor Laws; (b) anyone commences an involuntary case against a Party under Title 11 of the United States Code or the corresponding provisions of any successor Laws and either (i) the case is not dismissed by midnight at the end of the [\*\*\*]th day after commencement or (ii) the court before which the case is pending issues an order for relief or similar order approving the case; (c) a court of competent jurisdiction appoints, or a Party makes an assignment of all or substantially all of its assets to, a custodian (as that term is defined in Title 11 of the United States Code or the corresponding provisions of any successor Laws) for its company or all or substantially all of its assets; or (d) a Party fails generally to pay its debts as they become due (unless those debts are subject to a good-faith dispute as to liability or amount) or acknowledges in writing that it is unable to do so; or

Upon the occurrence and continuance (as applicable) of any Sun Country Event of Default, Amazon may elect, in its sole discretion within [\*\*\*] days of the later of the initial occurrence of the event or the date that Amazon first becomes aware of the event, to terminate this Agreement in its entirety, to terminate any or all affected Work Orders, or to terminate all Work Orders with the affected Sun Country Provider immediately upon giving written notice of such Event of Default to Sun Country. In the event that a Party terminates this Agreement or any affected Work Order due to an Event of Default by the other Party, it will be entitled, without prejudice, to any other remedy which it may have at law or in equity, terminate this Agreement by giving notice of such termination to the other Party [\*\*\*]. In connection with an early termination of this Agreement or any Aircraft Sublease the applicable Carrier will return the Aircraft to Amazon in "as is-where is" condition if the Aircraft was maintained at the time of such return in accordance with the terms and conditions of the applicable Aircraft Sublease. Under no circumstance will the financial or indemnification obligations of either Party under this Agreement be altered or increased as a result of the occurrence of an Event of Default under any Aircraft Sublease, and pursuant to Section 13.13 of this Agreement, certain of the remedial provisions of the Aircraft Subleases will not apply.

4.6 No Termination or Other Payment on Expiration. Except as set forth in this Section 4, no Party be entitled to any termination payment, severance payment, penalty, damages, loss of goodwill, prospective profits, anticipated income, or other compensation in any form or manner (including on account of any expenditures, investments, leases, or commitments made by such Party) based upon the expiration of this Agreement at the end of its Term.

4.7 Work Orders. A Work Order will be effective upon the Work Order Effective Date and will terminate on the earliest of: (a) [\*\*\*] days after Amazon provides written notice of termination for convenience; (b) immediately if a Party is in material breach of the Work Order (or Agreement terms applicable to the Work Order) and fails to cure such breach in accordance with Section 4.5 of this Agreement (including the expiration of any applicable cure period); (c) immediately upon the expiration or prior termination of this Agreement; or (d) on the Expiration Date of the Work Order. The “Expiration Date” of all Work Orders that are not Carrier Work Orders will be as stated in the relevant Work Order. Each Carrier Work Order will have an Expiration Date that is coterminous with the Term of this Agreement. With respect to any termination of a Carrier Work Order for convenience by Amazon under subsection (a) above: [\*\*\*]. Amazon will not be subject to any penalty, or otherwise be responsible for any reimbursement of costs or expenses (except, for clarity, amounts due and payable prior to the termination date), in connection with the termination of a Work Order as contemplated by this Section 4.7.

4.8 Subleases. The term of each Aircraft Sublease will be coterminous with the term of the corresponding Carrier Work Order.

4.9 Post-Expiration Agreement. Amazon and Sun Country will, at Amazon’s sole option and upon its prior written request, make all commercially reasonable efforts to enter into an interim agreement in anticipation of the expiration of this Agreement for Sun Country to assist Amazon in the transition from this Agreement (“Post-Expiration Agreement”). The Post-Expiration agreement will: (a) become effective upon the expiration of this Agreement and thereafter remain in effect for a term of up to [\*\*\*] as mutually agreed between Amazon and Sun Country; and (b) be designed to facilitate an orderly transition of the Aircraft to a Third Party Carrier.

4.10 Survival. No termination or expiration of this Agreement or any Work Order for any reason will relieve any Party of any liability or obligation to the extent accrued prior to such termination or expiration. The following provisions will survive termination or expiration of this Agreement under any circumstance: Reports, Audits and Record Retention (Section 2.17), Term and Termination (this Section 4), Representations and Warranties (Section 5), Confidentiality and Proprietary Rights (Section 6), Defense/Indemnity (Section 7), Loss or Damage to Goods (Section 8), Insurance (Section 9), Taxes (Section 11), General (Section 13).

## 5. REPRESENTATIONS AND WARRANTIES; COVENANTS

Each Party represents, warrants and covenants to the other Parties, as applicable:

5.1 Authority. Each Party has all right, power and authority to enter into this Agreement and perform its obligations under this Agreement. Each Party’s entry into and performance of its obligations under this Agreement will not (with or without the passage of time or giving of notice or both) violate any governing document (including articles of organization, certificate of incorporation or bylaws as applicable), any third party agreement (including any Compliance Requirement or Insurance Requirement) or arrangement or any Law, in each case by which such Party is bound or to which such Party or its assets is subject.



5.2 Organization; Binding Agreement. Each Party is a corporation duly organized, validly existing and in good standing under the Laws of the state in which it is incorporated. This Agreement constitutes a legally valid and binding agreement of the Parties, enforceable against each Party in accordance with its terms, except as may be limited by applicable bankruptcy, insolvency, reorganization, moratorium or similar Laws affecting generally the enforcement of creditors' rights and remedies and general principles of equity. Each Party will comply and will require their Personnel to comply in all respects with all Laws in connection with its performance under this Agreement. Sun Country will notify Amazon in writing as promptly as practicable of the existence of any strike, lockout, job action, industrial disturbance, service disruption or other labor dispute that could reasonably be expected to impair its or a Sun Country Provider's ability to perform the Services.

5.3 Service Representations. Sun Country, each Sun Country Provider, and their respective Personnel, as applicable, will: (a) perform the Services in a competent and workmanlike manner in accordance with the level of professional care customarily observed by highly skilled professionals rendering similar services; (b) comply with the Performance Standards; (c) promptly upon receipt of or having actual knowledge notify Amazon of any accident, incident, or event that impairs the safety of or delays delivery of shipments, and will use reasonable care and due diligence in the protection of the goods or shipments in their possession and control; and (d) at all times have sufficient equipment, Personnel and resources available to fulfill its obligations under each Work Order then in effect (and, in any case in which such Sun Country Provider believes, in its reasonable business judgment, that it does not have sufficient equipment, Personnel and resources available to handle all Amazon capacity requirements, such Sun Country Provider will promptly notify Amazon in writing).

5.4 Proprietary Rights. The Services performed by or on behalf of Sun Country or a Sun Country Provider and any reports, information, data, or other materials provided by or on behalf of Sun Country or a Sun Country Provider (including Amazon's exercise of its rights under this Agreement with respect to such Services and other materials) will not violate, misappropriate or infringe upon Amazon's or any third party's trademarks, trade secrets, confidentiality rights, copyrights, patents, or any other intellectual property or proprietary rights in any jurisdiction (collectively, "Proprietary Rights").

5.5 Compliance. Sun Country, each Sun Country Provider, and their respective Personnel will: (a) comply with all applicable Laws in carrying out the Services; (b) will hold and comply with all required licenses, permits and approvals; (c) acknowledge that the Amazon's Code of Business Conduct and Ethics, which is posted at <http://phx.corporate-ir.net/phoenix.zhtml?c=97664&p=irol-govConduct> on the Effective Date, prohibits the paying of bribes to anyone for any reason, whether in dealings with governments or the private sector, and contains principles that are similar to Sun Country's own Code of Ethics and Business Conduct (last adopted by its board of directors on August 8, 2018) and, further that Sun Country, each Sun Country Provider, and their respective Personnel will be in compliance with Sun Country's Code of Ethics and Business Conduct; and (d) comply with any social compliance and safety requirements made available by Amazon to Sun Country and such Sun Country Providers and Amazon's Supplier Code of Conduct, which is posted at <https://d39w7f4ix9f5s9.cloudfront.net/43/8e/934d99c741e5b8bb0ada0c173dbe/amazon->

supplier-code-of-conduct-16sep2019.pdf on the Effective Date (the requirements described in [Section 5.10](#) and in this [Section 5.5](#), the “[Compliance Requirements](#)”). Sun Country and the Sun Country Providers will maintain true, accurate and complete books and records concerning any payments made to another party by Sun Country or a Sun Country Provider under this Agreement, including on behalf of Amazon.

5.6 [Common Carrier](#). Each Carrier is a Common Carrier.

5.7 [Filings](#). Where required by applicable Law, Sun Country and each Sun Country Provider will ensure that all rates and terms and conditions that are the subject of this Agreement are filed with the appropriate Governmental Entity, if any, and, unless such shorter period is required by applicable Law, Sun Country or such Sun Country Provider will provide Amazon at least [\*\*\*] Business Days’ notice in advance of any such filing.

5.8 [No Liens](#). Neither Sun Country nor any Sun Country Provider will hold, and to the fullest extent allowed by applicable Law, Sun Country and each Sun Country Provider hereby waive all rights to, any lien or encumbrance upon any Amazon shipments, property or assets, including any packages, parcels or other cargo or transportation units tendered to a Carrier or any documents relating thereto, in each case on behalf of itself and any third party landlord, contractor or other business relation engaged by Sun Country or such Sun Country Provider; except any lien or encumbrance not allowed to be waived by applicable Law will not be asserted.

5.9 [Flight Operations](#). Each Carrier will: (a) hold and operate under a FAA air carrier certificate and operations specifications issued under 14 C.F.R. Part 119 authorizing it to engage in operations under 14 C.F.R. Parts 121 or 135 and corresponding DOT certificate of public convenience and necessity (or equivalent exemption authority) authorizing such Carrier to conduct the air transportation services contemplated under this Agreement (collectively, “[Operating Authority](#)”); (b) only perform the Services using Aircraft covered by the Operating Authority; (c) at its sole expense (subject to any requirements set forth in the applicable Carrier Work Order for reimbursements to Sun Country), perform or cause to be performed all ongoing maintenance, inspections, repairs, modifications, preventive maintenance, fueling, installations, and overhaul work for the Aircraft in accordance with the Operating Authority, such Carrier’s FAA-approved maintenance and inspection program and other applicable Laws; (d) ensure that the Aircraft comply with all applicable airworthiness directives, mandatory service bulletins, alert bulletins, manufacturers’ releases and insurer’s requirements concerning the Aircraft; (e) at all times be the operator of the Aircraft and have complete, uninterrupted, effective and sustainable operational control of the Aircraft in accordance with the Operating Authority and other applicable Laws; (f) have possession, command and control of the Aircraft within the meaning of applicable Laws; (g) ensure that the pilot-in-command of the Aircraft will have absolute discretion in all matters concerning the preparation of the Aircraft for flight, including the load carried and its distribution, the decision whether or not a particular flight will be undertaken, the route to be flown and all matters relating to the operation of the Aircraft; (h) ensure that Flight Crew will have final and complete authority to cancel any flight for any reason or condition which in its judgment could compromise the safety or security of the flight or compliance with applicable Laws and may take any other

action which in the judgment of the pilot-in-command is necessitated by consideration of safety, security compliance with applicable Laws; (i) be solely responsible for determining that containers and pallets (“Unit Load Devices” or “ULDs”) and related equipment (including nets, tie downs and tensioning equipment) are suitable for air transportation in accordance with applicable Laws; and (j) not provide the Services at, to or from any origin or destination locations located outside of the geographic area of the United States absent a mutually agreed amendment to this Agreement (however this subsection (j) will not limit lawful overflight of non-U.S. jurisdictions by any Carrier in the performance of its Services under this Agreement); (collectively, the “Flight Operations Requirements”).

5.10 Trade Restrictions. Sun Country and each Sun Country Provider represent and warrant that: (a) neither they nor their financial institution(s) are subject to sanctions or otherwise designated on any list of prohibited or restricted parties or owned or controlled by such a party, including but not limited to the lists maintained by the United Nations Security Council, the US Government (e.g., the US Department of Treasury’s Specially Designated Nationals list and Foreign Sanctions Evaders list and the US Department of Commerce’s Entity List), the European Union or its member states, or other applicable Governmental Entity; and (b) they will not directly or indirectly export, re-export, transmit, or cause to be exported, re-exported or transmitted, any commodities, software or technology to any country, individual, corporation, organization, or entity to which such export, re-export, or transmission is restricted or prohibited, including any country, individual, corporation, organization, or entity under sanctions or embargoes administered by the United Nations, US Departments of State, Treasury or Commerce, the European Union, or any other applicable Governmental Entity.

## **6. CONFIDENTIALITY; PROPRIETARY RIGHTS**

6.1 Confidentiality. The Parties will comply with the terms of any nondisclosure agreement between Sun Country and Amazon, as may be amended, superseded or otherwise modified from time to time (“NDA”). In the case of any Third Party Carrier, Sun Country will procure from such Third Party Carrier an executed nondisclosure agreement using Amazon’s form. The existence of this Agreement, its terms and conditions, and any other information obtained from Amazon in connection with this Agreement or related to the Services that is identified as confidential or proprietary or that, given the nature of such information or the manner of its disclosure, reasonably should be considered confidential or proprietary (including information relating to the contents and recipients of packages, parcels and other cargo or transportation units, Amazon’s technology, customers, business plans, marketing activities, and finances) will be confidential information subject to the NDA. If no such agreement exists or if it has subsequently terminated or expired, Sun Country, each Sun Country Provider, and their respective Personnel: (a) will protect and keep confidential the existence of this Agreement, its terms and conditions and any other information obtained from Amazon in connection with this Agreement or related to the Services that is identified as confidential or proprietary or that, given the nature of such information or the manner of its disclosure, reasonably should be considered confidential or proprietary (including all information relating to Amazon’s technology, customers, business plans, marketing activities, and finances); (b) will use such information only for the purpose(s) for which it was originally disclosed and in any case only for the purpose of fulfilling its obligations under this Agreement;

and (c) will return all such written information to Amazon promptly upon the termination of this Agreement by expiration or otherwise. All such information will remain the exclusive property of Amazon, and Sun Country and the applicable Sun Country Providers will not have any right to use such information except as expressly provided in this Agreement and the NDA. Notwithstanding the foregoing, in the event that Sun Country determines that it required by applicable Law to file this Agreement with the U.S. Securities and Exchange Commission, it will promptly notify Amazon of such determination in writing and the Parties will reasonably cooperate in seeking confidential treatment of the Agreement to the maximum extent permitted by such applicable Law and Sun Country will be entitled to file such agreed version of this Agreement with the U.S. Securities and Exchange Commission. For clarity, Sun Country and the Sun Country Providers acknowledge and agree that this Section 6.1 strictly prohibits Sun Country Personnel from engaging in any speculative discussion relating to Amazon's technology, customers, business plans, marketing activities, or finances at industry conferences or similar public events without the prior written authorization of an Amazon Leadership Representative (to be granted or withheld in Amazon's sole discretion).

6.2 Publicity Restriction. Neither Party will use any trade name, trademark, service mark, logo or commercial symbol, or any other Proprietary Rights of the other Party in any manner (including use in any client list, press release, advertisement or other promotional material) without prior written authorization of same by the other Party (to be granted or withheld in such Party's sole discretion), including, for clarity, such authorization with respect to the Party's reasonable use to fulfill investor communications responsibilities as a publicly traded company in accordance with applicable Law.

6.3 Work Product Ownership. If Sun Country or a Sun Country Provider delivers or is required to deliver to Amazon any work product in connection with the Services, Amazon owns, or upon assignment by the creator will own, all right, title and interest (including, all copyrights and any other intellectual property rights) in such work product. The work product has been specially ordered and commissioned by Amazon as "work made for hire" for copyright purposes; or, to the extent such deliverable does not so qualify, Sun Country or such Sun Country Provider (as applicable) hereby assigns to Amazon, its successors and assigns, all right, title and interest in and to the work product.

6.4 Personal Information. Neither Sun Country nor any Sun Country Provider will use any personally identifiable information it receives concerning Amazon customers, suppliers, or Personnel, including names, addresses, e-mail addresses, and telephone numbers (collectively "Personal Information"), except solely for purposes of providing Services under this Agreement. Neither Sun Country nor any Sun Country Provider will transfer, rent, barter, trade, disclose, or sell such information and none of them will develop lists of or aggregate such information. To the extent permitted by Law, Sun Country and each Sun Country Provider will delete all instances (including backups and other copies) of Personal Information associated with each shipment within [\*\*\*]days after completing the shipment. If Sun Country or a Sun Country Provider is required by Law to maintain records more than [\*\*\*] days after shipment, Sun Country or such Sun Country Provider will delete the Personal Information as soon as it is permitted. Before disposing of any hardware, media or software (including any sale or transfer of such material or any disposition of Sun Country's or such Sun Country

Provider's business) that contains or previously contained Personal Information, Sun Country or such Sun Country Provider will perform a complete forensic destruction of the Personal Information (which may include a physical destruction, preferably incineration, or secure data wipe) such that no such information can be recovered or retrieved.

## 7. DEFENSE/INDEMNITY

7.1 To the fullest extent permitted by applicable Law, Sun Country, jointly together with each Sun Country Provider, and each Sun Country Provider, jointly with Sun Country but severally among other Sun Country Providers with respect to Services performed by such other Sun Country Providers, hereby releases and will indemnify, defend and hold harmless Amazon, each of its Affiliates, and their respective directors, officers, Personnel, shareholders, successors, and assigns of the foregoing (the "Amazon Indemnified Parties"), from and against any loss, claim, damage, suit, judgment, settlement, cost, expense, interest, fees, fines, penalties, government investigation or inquiry, remediation, and mitigation efforts regardless of whether required by Law and any other liability and costs and expenses relating thereto (including reasonable attorneys' fees, expert fees and court costs) arising out of, in connection with, or related to any third party allegation or claim (collectively, "Claims") based on or relating to: (a) the death of or injury to any Person whomsoever, including Personnel of the Amazon Indemnified Parties or the Sun Country Indemnified Parties, loss of, damage to, delay or destruction of any goods or property whatsoever, including cargo, the Aircraft and any property of the Sun Country Indemnified Parties or the Amazon Indemnified Parties or third parties, in any case caused by, arising out of or in connection with an act or omission by Sun Country, a Sun Country Provider, or any of their respective Affiliates or Personnel in connection with the performance of the Services or its possession, use, operation or maintenance of the Aircraft, including any equipment, machinery, spare engines and spare parts utilized to provide such Services including indemnification claim arising under Section 10 of any Aircraft Sublease (provided that to the extent an operational indemnity arises hereunder and would be covered by Section 10 of an Aircraft Sublease, the limitations for such indemnity set forth in Section 10 of the Aircraft Sublease will apply); (b) Sun Country or any Sun Country Provider's breach of any term of this Agreement, including any penalties, fines, or other costs associated with any government investigation relating thereto; (c) any infringement or misappropriation of any Proprietary Right; (d) any theft, embezzlement, forgery, fraud or other criminal act of Sun Country or its Affiliates or any of their respective Personnel; or (e) any allegation or claim of gross negligence, willful misconduct or strict liability by or of Sun Country or a Sun Country Provider arising from an act or omission by Sun Country, a Sun Country Provider, or any of the respective Personnel of the foregoing. However, the foregoing indemnification obligation does not apply to an Amazon Indemnified Party to the extent such Claim: (i) results solely from the gross negligence or willful misconduct of such Amazon Indemnified Party; or (ii) is governed by Section 8 of this Agreement, in which case Section 8 will control with respect to the Claim.

7.2 Sun Country's and each Sun Country Provider's duty to defend is independent of its duty to indemnify. Sun Country's and each Sun Country Provider's obligations under this Section 7 are independent of all of its other obligations under this Agreement. Sun Country and the applicable Sun Country Provider will use counsel reasonably satisfactory to Amazon to defend each Claim, and Amazon will reasonably cooperate (at Sun Country's or Sun Country Provider's

expense, as the case may be) in the defense. Neither Sun Country nor any Sun Country Provider will consent to the entry of any judgment or enter into any settlement without Amazon's prior written consent, which may not be unreasonably withheld, delayed, or conditioned. Subject to the foregoing, Amazon will have the additional right to participate at any time and at its own expense in any indemnification action or related settlement negotiations using counsel of its own choice. The Parties agree that this Section 7 does not apply to claims for loss or damage under Section 8.

7.3 To the fullest extent permitted by applicable Law, Amazon will indemnify and hold Sun Country, each Sun Country Provider (with respect to Services performed by such Sun Country Provider), each of their respective Affiliates, and the respective directors, officers, Personnel, successors, and assigns of the foregoing (collectively, the "Sun Country Indemnified Parties"), harmless from any Claim based on or relating to: (a) the death of or injury to any Person whomsoever, including Personnel of the Amazon Indemnified Parties or the Sun Country Indemnified Parties, loss of, damage to, delay or destruction of any goods or property whatsoever, including cargo, the Aircraft and any property of the Sun Country Indemnified Parties or the Amazon Indemnified Parties or third parties, in any case caused by, arising out of or in connection with an act or omission by Amazon, or any of its Affiliates or Personnel in connection with the performance with ground handling functions performed by Amazon pursuant to Section 2.8.1; or (b) cargo tendered directly by Amazon for transportation under this Agreement; (c) Amazon's breach of any term of this Agreement, including any penalties, fines, or other costs associated with any government investigation relating thereto; (d) any infringement or misappropriation of any Proprietary Right; (e) any theft, embezzlement, forgery, fraud or other criminal act of Amazon; or (f) any allegation or claim of gross negligence, willful misconduct or strict liability by or of Amazon arising from an act or omission by Amazon or its Personnel of the foregoing. However, the foregoing indemnification obligation does not apply to a Sun Country Indemnified Party to the extent such Claim results: (y) solely from the gross negligence or willful misconduct of such Sun Country Indemnified Party; or (z) with respect to clause (b) from a violation of applicable Law with respect to such cargo by such Sun Country Indemnified Party. For any Claim under this Section 7.3 that may be covered under the applicable SGHA, the Carrier must first pursue all rights and remedies available under such SGHA.

7.4 Amazon's duty to defend is independent of its duty to indemnify. Amazon's obligations under this Section 7 are independent of all of its other obligations under this Agreement. Amazon will use counsel reasonably satisfactory to Sun Country to defend each Claim, and Sun Country and any applicable Sun Country Indemnified Party will reasonably cooperate (at Amazon's expense) in the defense. Amazon will not consent to the entry of any judgment or enter into any settlement without Sun Country's prior written consent, which may not be unreasonably withheld, delayed, or conditioned. Subject to the foregoing, the applicable Sun Country Indemnified Party will have the additional right to participate at any time and at its own expense in any indemnification action or related settlement negotiations using counsel of its own choice. The Parties agree that this Section 7 does not apply to claims for loss or damage under Section 8.

## 8. LOSS OR DAMAGE TO GOODS

8.1 Liability Limit. Neither Sun Country nor any Sun Country Provider will be liable for any loss, theft or damage to goods for any action: (a) unrelated to Sun Country's performance of the Services, (b) arising solely as a result of Force Majeure, (c) that is reasonable wear and tear or (d) relating solely to ground equipment or functions that Amazon is performing under Section 2.8 (to the extent not provided by a Sun Country Provider under a Ground Services Work Order) ("Excluded Claims"). To the extent that there is any loss, theft or damage to goods for any action unrelated to Excluded Claims Sun Country and the applicable Sun Country Provider's liability will be limited to \$[\*\*\*] per package (subject to a limitation of \$[\*\*\*] per shipment), except (i) to the extent such loss or damage is directly attributable to the gross negligence or misconduct of Sun Country, any Sun Country Providers, or their respective Personnel or (ii) as such amounts may be increased pursuant to Section 8.2. For purposes of this Section 8.1, a "shipment" refers to all of the packages to be transported together on any given flight. For all purposes hereunder, a "package" refers to an individual sellable unit, which may be shipped by a Carrier as part of a larger transportation unit containing multiple packages.

8.2 Additional Coverage. With respect to any shipment(s) or class(es) of shipments, Amazon, Sun Country, and each Sun Country Provider (all acting in good faith), with the concurrence of Sun Country's or the Sun Country Provider's insurers (as applicable), may reasonably agree on a special compensation to be paid by Amazon to increase the liability of the Sun Country or the Sun Country Provider in excess of the amount per package specified above in case of any loss, theft or damage to goods, effective upon mutual written agreement of authorized representatives of the Parties (including via email) indicating the shipment(s) or class(es) covered, the increased limit of Sun Country's or the Sun Country Provider's liability and the special compensation payable.

8.3 Claims. Subject to the limitations in Section 8.1, each Sun Country Provider will be responsible for all loss or damage to packages while in the possession, care, or control of such Sun Country Provider and all of their respective Personnel and will pay claims at Amazon's actual cost, including replacement cost of goods and direct costs associated with packaging, handling and shipping. Claims for lost or damaged packages may be based upon Amazon's manifest and any other materially relevant information, may be initiated electronically (including via e-mail), and may be filed at any time within [\*\*\*] days after the item was tendered to such Sun Country Provider. The Sun Country Provider will acknowledge claims within [\*\*\*] days of receipt and will process all claims to conclusion and pay Amazon or credit its account, to the extent applicable, within [\*\*\*] days of receipt.

8.4 Cooperation. Sun Country and each Sun Country Provider agrees to cooperate as reasonably requested at their respective expense with Amazon loss prevention and investigative personnel in the conduct of investigations and preparation of reports related to loss, damage, fraud, shrinkage, mis-delivery, theft and other matters of mutual concern.

## 9. INSURANCE

9.1 Sun Country Provider Insurance Coverage. Throughout the Term, and as otherwise required herein, Sun Country and each Sun Country Provider, as applicable, will carry at its expense:

9.1.1 Aviation Liability insurance as of the Effective Date and continuing for a period of [\*\*\*] following the end of the Term or, if earlier, until the next major aircraft maintenance check, including commercial general liability insurance, third party legal liability including passenger liability, third party war and allied perils, property damage liability, premises liability, products and completed operations liability with respect to any maintenance, and contractual liability (which, without limitation, will specifically insure the indemnity of Carrier in Section 7 hereof subject to the terms and conditions of such policy), and provide breach of warranty clause, severability of interest clause and a waiver of subrogation in favor of the Additional Insureds, and evidence worldwide policy territory, if applicable, subject to any exclusions then standard in the commercial aviation insurance market, with limits of not less than \$[\*\*\*] combined single limit for bodily injury and property damage each occurrence (and \$[\*\*\*] per occurrence and in the aggregate with respects war and allied perils);

9.1.2 Business Automobile liability insurance as required by Law in all jurisdictions where Sun Country or a Sun Country Provider performs Services for Amazon with a combined single limit of not less than \$[\*\*\*] per occurrence;

9.1.3 Worker's Compensation insurance in all jurisdictions where Sun Country or a Sun Country Provider performs Services for Amazon, and Employer's Liability insurance with a limit of not less than \$[\*\*\*] per occurrence, both with a waiver of subrogation in favor of the Additional Insureds;

9.1.4 Aircraft Hull and Hull War insurance that, on or prior to the Services Commencement Date, each Carrier will maintain (or cause to be maintained) in full force and effect, on terms substantially similar to and no less favorable than insurance carried by the Carrier on similar aircraft in its fleet, all risk-ground and flight aircraft hull insurance covering the Aircraft including coverage of the engines and parts while temporarily removed from or not installed on the Aircraft and not replaced with similar components in amounts denominated and payable in United States Dollars not less than, in respect of the Aircraft, the Agreed Value, and with respect to any engines or parts while removed from the Aircraft on a replacement value basis. The Carrier will maintain such insurance covering any loss or damage arising from: (a) war, invasion, acts of foreign enemies, hostilities (whether ware be declared or not), civil war, rebellion, revolution, insurrection, martial law, military or usurped power, or attempts at usurpation of power; (b) strikes, riots, civil commotions, or labor disturbances; (c) any act of one or more persons, whether or not agents of a sovereign power, for political or terrorist purposes and whether the loss or damage resulting therefrom is accidental or intentional; (d) any malicious act or act of sabotage; (e) confiscation, nationalization, seizure, restraint, detention, appropriation, requisition for title, or use by or under the order of any Governmental Entity; and (f) hijacking or any unlawful seizure or wrongful exercise of control of the Aircraft or any airframe on which any engine is installed or crew in flight (including any attempt at such seizure or control) made by any person or persons on board the Aircraft or such airframe acting without the consent of the insured.



9.1.5 Sun Country and each Sun Country Provider, as applicable, covenants that all policies and subsequent policies taken out in accordance with this Section 9.1.5 will: (a) be issued by insurance companies or underwriters of internationally recognized standing in the aviation industry; (b) with respect to the insurance required under Section 9.1.4, be endorsed to name Amazon (and as directed by Amazon, Amazon's Aircraft lessor and any other party with an interest in the Aircraft as may be reasonably requested by Amazon), as the loss payee and/or contract party to the extent of its interests in respect of hull claims that become payable on the basis of a total loss and will provide that any other loss will be settled (net of any relevant policy deductible) with Amazon as may be necessary to repair the Aircraft unless otherwise agreed in writing; (c) provide that insurers will waive all rights of subrogation as against Amazon and each of its Affiliates and their officers, directors, employees, lessors and any other parties as reasonably requested by Amazon ("Amazon Parties"); (d) waive any right of the insurers to any setoff, counterclaim or other deduction against the Amazon Parties; (e) with respect to the insurance required under Section 9.1.4, contain a 50/50 claims funding clause in the form of Lloyd's standard provision AVS103 in the event of a dispute as to which policy will pay in the event of a loss; and (f) have deductibles (not applicable in case of a total, constructive total and/or arranged total loss) standard in the industry which do not exceed, per occurrence, the lesser of (i) \$[\*\*\*] and (ii) such amounts carried by the Carrier with respect to other aircraft similar to the Aircraft and operated on similar routes or which are otherwise reasonably acceptable to, and approved in writing by Amazon, except that any deductibles will be assumed by and at the sole risk of Sun Country or the Sun Country Provider and, to the extent applicable, will be paid by Sun Country or such Sun Country Provider, except that Amazon will pay any deductible to the extent that it was due and payable (for clarity, and not subject to a good faith dispute) to a Carrier by one of Amazon's subcontractors and is more than [\*\*\*] days past due.

9.1.6 All insurance coverage will be subject to Endorsement AVN67B (or a comparable endorsement); and

9.1.7 Cargo legal liability insurance with limits sufficient to cover the Carrier's obligations per Section 8, but in no event less than \$[\*\*\*] per loss. Any excess liability above the amounts specified above (including amounts to "declare" values of a shipment) shall be for the account of Amazon.

9.2 Additional Policy Requirements. All such policies will also cover Sun Country's and a Sun Country Provider's (as applicable) liability under this Agreement for any acts by subcontractors and will afford coverage for the Aircraft both in flight and not in flight, as applicable. In the event that any insurance on the Aircraft which is required by this Section 9 is invalidated or is otherwise not in effect for any reason, the Aircraft must not be used to perform the Services until such time as the insurance is again valid and in full force and effect; except that such lapse in insurance will not excuse a breach of the Carrier's obligations under this Agreement. Sun Country and the Sun Country Provider (as applicable) will not permit its insurance policy coverage limits to be reduced below the minimum amounts set forth above or any such policy to be cancelled or allowed to expire without at least [\*\*\*] days ([\*\*\*] days for nonpayment of premiums and [\*\*\*] days, or such other period as is then customarily obtainable in the industry, in the case of any hull war and allied perils coverage) prior written notice to Amazon (provided that such notice will be a lesser period customary in the commercial

aviation insurance industry with respect to war risk coverage). Sun Country and each Sun Country Provider (as applicable) will cause Amazon and each of its Affiliates and their officers, directors, employees, lessors and any other parties required by Amazon, at Amazon's reasonable request, ("Additional Insureds") to be named as additional insureds and coverage will be primary, without right of contribution from the Additional Insureds or their insurers on the policies required pursuant to this Section 9.1.1 and 9.1.2 and will submit certificates of insurance for the coverage required under this Section 9 at commencement of the Services and at Amazon's request. The Carrier will send certificates of insurance via email to [\*\*\*]. Amazon's knowledge or approval of any of Sun Country's or a Sun Country Provider's insurance policies does not relieve or limit any of Sun Country's or such Sun Country Provider's obligations under this Agreement, including liability under Section 7 or Section 8 for claims exceeding required insurance limits. The requirements described in this Section 9 are collectively referred to as the "Insurance Requirements".

9.3 Amazon Insurance. Throughout the term of this Agreement, and as otherwise required herein, Amazon (including its Affiliates, as applicable), will carry at its expense: (a) Commercial General Liability insurance with limits of not less than \$[\*\*\*] per occurrence and \$[\*\*\*] in the aggregate, (b) Worker's Compensation insurance, or similar, in all jurisdictions in the United States where Amazon Personnel perform services under this Agreement as required by law; and Employer's Liability insurance with a limit of not less than \$1 million per occurrence, and (c) Business Automobile Liability insurance as required by law with a combined single limit of not less than \$[\*\*\*] per occurrence. Amazon will provide certificates of insurance for the coverage required under this Section 9.3 upon the commencement of the Services in such jurisdictions and at Sun Country's request.

## **10. PERSONNEL; INDEPENDENT CONTRACTORS**

10.1 Relationship of the Parties. Each of Sun Country and Amazon are independent contractors. Nothing in this Agreement is to be construed as creating an agency, partnership, or joint venture relationship between or among any of the Parties, and no Party will be entitled to act on behalf of or bind the other in any manner, except to extent expressly set forth in this Agreement or any Work Order (if at all).

10.2 Personnel. All Personnel furnished by a Party to provide Services are employees, agents, or subcontractors of such Party and are not employees, agents, or subcontractors of the other Party. Each Party has: (a) exclusive responsibility for and exclusive control over its Personnel, its labor and employee relations, and its policies relating to wages, hours, working conditions, and other employment conditions; (b) the exclusive right to hire, transfer, suspend, layoff, recall, promote, discipline, discharge, and adjust grievances with its respective Personnel; and (c) responsibility for all salaries and other compensation of their respective Personnel, all deductions and withholdings from the salaries and other compensation of its respective Personnel and for paying all contributions, taxes and assessments. Each Party's Personnel are not eligible to participate in any employment benefit plans or other benefits available to the other Party's employees. Each Party will ensure that its respective Personnel comply with the other Party's rules and policies while on the other Party's premises (to the extent that the other Party has informed the Party of such rules and policies with reasonable

prior notice), and, for transportation to or from the premises of a customer, supplier, or other business relation of the other Party, each Party will ensure that their respective Personnel comply with such third party's rules and policies while on such third party's premises (to the extent such Party has received reasonable prior notice of the rules and policies). Neither Party's Personnel has any authority to bind the other Party to any agreement or obligation.

10.3 **Subcontractors.** Notwithstanding the existence or terms of any subcontract or any contracting of Services as described in Section 10.3, Sun Country and each Sun Country Provider will remain jointly and severally responsible for the full performance of the Services in accordance with the Performance Standards and the other requirements of this Agreement. Sun Country and each Sun Country Provider will remain responsible for the full performance of the Services in accordance with the Performance Standards and other requirements of this Agreement and any applicable Work Order to the extent such Sun Country Provider is party to such Work Order. The terms and conditions of this Agreement and any and all Work Orders are binding upon Sun Country Providers, their Affiliates and their respective Personnel, to the extent a Sun Country Provider is party to such Work Orders. To extent a Sun Country Provider is party to any Work Orders, such Sun Country Provider will: (a) ensure that such entities and individuals comply with this Agreement and such Work Orders; and (b) be responsible for all acts, omissions, negligence and misconduct of such entities and individuals. Such Sun Country Provider will also ensure that all subcontractors effectively and irrevocably waive, to the fullest extent permitted by Law, any lien upon (or other right with respect to) the packages, parcels and other cargo or transportation units transported, regardless of whether such subcontractor would otherwise be entitled to such lien or other rights under contract or applicable Law (or if and to the extent any such lien may not be waived under applicable Law, agree not to assert such lien), and waive any claim (including for amounts owed for delivery services) against Amazon and any recipient. Without in any way limiting any of Sun Country's or any Sun Country Provider's obligations or Amazon's rights under Section 7, if any subcontractor asserts any claim, demand, suit, or action ("Sun Country Subcontractor Claim") against Amazon or any of its Affiliates and Sun Country or a Sun Country Provider, as the case may be, is then undergoing any bankruptcy proceeding, then Amazon may at its sole discretion, but is not obligated to, defend or settle such Sun Country Subcontractor Claim at the cost and expense of Sun Country, except that, for clarity, if Amazon incurs or pays any loss, damage, settlement, cost, expense, or any other liability (including reasonable attorneys' fees) relating to such Sun Country Subcontractor Claim, Amazon may set off such amounts in full against any amounts Amazon owes to Sun Country or demand immediate full reimbursement from Sun Country or such Sun Country Provider. Amazon will remain responsible for the full performance if its obligations under this Agreement. To extent Amazon subcontracts any of its obligations under this Agreement, Amazon will: (a) ensure that such entities and individuals comply with this Agreement; and (b) be responsible for all acts, omissions, gross negligence and willful misconduct of such entities and individuals. Without in any way limiting any of Amazon's obligations or Sun Country's or any Sun Country Provider's rights under Section 7, if any subcontractor asserts any claim, demand, suit, or action ("Amazon Subcontractor Claim") against Sun Country or any Sun Country Provider, as the case may be, is then undergoing any bankruptcy proceeding, then Sun Country may at its sole discretion, but is not obligated to, defend or settle such Amazon Subcontractor Claim at the cost and expense of Amazon, except that, for clarity, if Sun Country or any Sun Country Provider incurs

or pays any loss, damage, settlement, cost, expense, or any other liability (including reasonable attorneys' fees) relating to such Amazon Subcontractor Claim, Sun Country and the Sun Country Providers may set off such amounts in full against any amounts Sun Country owes to Amazon or demand immediate full reimbursement from Amazon.

## 11. TAXES

Sun Country and the Sun Country Providers are liable for, and agree to pay, all income, gross receipts, franchise, or similar taxes (including interest and penalties) associated with this Agreement or the Services provided under this Agreement that are imposed upon, as applicable, Sun Country or the Sun Country Providers ("Income Taxes").

Sun Country and each Sun Country Provider (as applicable) may charge and Amazon will be responsible for and will pay applicable national, state, or local sales or use taxes, excise or value added taxes that Sun Country or such Sun Country Provider is legally obligated to charge ("Transfer Taxes"), if those Transfer Taxes are stated on the original invoice that Sun Country or such Sun Country Provider provides to Amazon and Sun Country's or such Sun Country Provider's invoices state those Transfer Taxes separately and meet the appropriate tax requirements for a valid tax invoice. Amazon may provide Sun Country or the applicable Sun Country Provider an exemption certificate or equivalent information acceptable to the relevant taxing authority, in which case Sun Country or such Sun Country Provider will not collect (or, as applicable will charge a reduced rate) the Transfer Taxes covered by such certificate. Amazon may deduct or withhold any taxes that Amazon may be legally obligated to deduct or withhold from any amounts payable to Sun Country or the Sun Country Providers under this Agreement, and payment to Sun Country or a Sun Country Provider as reduced by such deductions or withholdings will constitute full payment and settlement to Sun Country or such Sun Country Provider of amounts payable under this Agreement. Throughout the term of this Agreement, Sun Country and each Sun Country Provider will provide or will cause Amazon to be provided with any forms, documents, or certifications as may be required for Amazon to satisfy any information reporting or withholding tax obligations with respect to any payments under this Agreement.

In the event that Sun Country, any Sun Country Provider, or Amazon fails to pay the Income Taxes or the Transfer Taxes (collectively, the "Taxes") that it is responsible for under this Section 11 and such Taxes are levied upon, assessed against, collected from or otherwise imposed upon another party, the party responsible for such Taxes under this Section 11 will immediately indemnify, defend, and hold the other harmless from and against all such indemnified Taxes, including any interest or penalties associated with such Taxes. As between Amazon and Sun Country, the provisions of Article 10 of each Aircraft Sublease shall not apply and the sole tax indemnity that either Party may look to for reimbursement is this Article 11.

## 12. CARRIER WORK ORDERS AND AIRCRAFT SUBLEASES

12.1 Committed Aircraft. Provided that this Agreement remains then in effect and no Sun Country Event of Default has occurred and is continuing, Amazon and Carrier will enter into a Carrier Work Order in the form of Exhibit B and an Aircraft Sublease in the form of Exhibit E concurrently with the Services Commencement Date for each of the Committed Aircraft.

12.2 Additional Aircraft. Subject to the Services Commencement Date being mutually agreed by the Parties, Sun Country will be prepared to provide Services with respect to Additional Aircraft owned by Amazon or leased to Amazon by a third party lessor to be operated under this Agreement. In such event, the Parties will enter into a Carrier Work Order in the form attached as Exhibit B and an Aircraft Sublease in the form of Exhibit E concurrently with the Services Commencement Date for the Additional Aircraft.

12.3 Delivery Process; Modifications. Amazon and Sun Country will mutually agree on arrangements for overseeing the conversion, modification, delivery conditions, managing Amazon's technical acceptance and delivery, Sun Country's delivery under an Aircraft Sublease, and, as applicable, ferrying the Aircraft from China to the United States, including the possible use of third party service providers. Aircraft will be modified to reflect the specifications and condition provided Exhibit H at Amazon's expense (for clarity, except for those items marked "preferred" in Section 2 of Exhibit H, which, to the extent accomplished at Sun Country's request, will be at Sun Country's expense) prior to entry into service under a Carrier Work Order, provided that Sun Country will not be responsible for any delays with respect to the Service Commencement Date due to circumstances outside of its reasonable control. Sun Country will make all commercially reasonable efforts to: (a) cooperate with Amazon with respect to same at no additional cost to Amazon, including drafting engineering orders as may be requested by the conversion or maintenance facility; and (b) sell-off any surplus Aircraft parts or components with a market value of \$[\*\*\*] or more, excluding customer specific items, that may exist following the modifications described in this Section 12.3, with the amount of the proceeds to be credited to Amazon on the next Monthly Invoice. The Parties will develop a mutually agreed conformity list for each aircraft that [\*\*\*].

### 13. GENERAL

13.1 Assignment or Change of Control by Sun Country Providers. Except as otherwise permitted in accordance with Section 2.3, the Parties acknowledge and agree that they have a strong and special personal and confidential relationship and trust in each Party's abilities and integrity in connection with the critical and difficult services contemplated under this Agreement and that neither Sun Country nor any Sun Country Provider may assign or otherwise transfer this Agreement (in whole or in part, directly, indirectly or by operation of Law), or subcontract or delegate any of their respective obligations, duties, or rights under this Agreement, without Amazon's prior written consent. Sun Country may assign this Agreement in its entirety in connection with an internal reorganization that does not constitute a Change of Control with Amazon's prior written consent (which consent will not be unreasonably withheld, delayed, or conditioned). Any attempt to assign, subcontract or delegate by Sun Country or a Sun Country Provider in violation of this Section 13.1 will be void in each instance. Sun Country or a Sun Country Provider (as applicable) will give Amazon prompt written notice of any Change of Control including, within [\*\*\*] Business Days of Amazon's request but in no event less than [\*\*\*] Business Days prior to the closing of the Change of Control transaction, a certification to Amazon by the acquiring or surviving entity (including

such other documentation as may be reasonably requested by Amazon), that it will continue providing the Services and that it will not otherwise discontinue, deprioritize or make business changes that will adversely impact Amazon's operations for the duration of the Term pursuant to the terms and conditions of this Agreement, the sufficiency of such documentation will be determined in Amazon's reasonable discretion. [\*\*\*]Subject to the foregoing in this Section 13.1, this Agreement will be binding upon, and inure to the benefit of, the Parties and their respective permitted successors and assigns.

13.2 Assignment by Amazon. Amazon may assign this Agreement or any Work Order to an Affiliate or in connection with any merger, reorganization, sale of all or substantially all of its assets, or any similar transaction without the consent of Sun Country.

13.3 Governing Law/Venue. The internal laws of the State of New York, excluding its conflicts of law rules, govern this Agreement. Amazon, Sun Country, and each Sun Country Provider irrevocably submit to the exclusive personal jurisdiction and venue in the federal and state courts in New York County, New York for any dispute arising out of this Agreement and waives all objections to jurisdiction and venue of such courts.

13.4 Notices. Notices under this Agreement are sufficient only if made in writing and delivered by personal delivery, certified mail, nationally-recognized overnight courier service, or email with confirmed read receipt, in each case in accordance with this Section 13.4. Such notice will be deemed effective: (a) when delivered personally; (b) three Business Days after sent by certified mail (return receipt requested) to the applicable address(es) set forth in the signature blocks below or in the applicable Work Order; (c) on the next business day after being sent by a nationally recognized courier service to the applicable address(es) set forth in the signature blocks below; or (d) on the day acknowledged in writing (email or otherwise) by the recipient Party when delivered by email, but only to the extent such email notice has been sent to an employee of the recipient Party having knowledge of the matter contained in the notice (and, in the case of notice to Amazon, with a copy to [\*\*\*]) and is conspicuously identified as a notice under this Agreement. Any notice to Amazon must include an additional copy to: Amazon.com, Inc. Attn: General Counsel P.O. Box 81226 Seattle, WA 98108-1226.

13.5 Amendment and Waiver. Except as set forth in this Section 13.5, this Agreement may not be amended, suspended, superseded or otherwise modified except by a written instrument, expressly identifying the modifications made and signed by the authorized representative of each of the Parties provided that, except as expressly provided in or with respect to any Work Order or exhibit, in each instance in this Agreement where reference has been made to establishing or deviating from the terms of this Agreement as "mutually agreed" (or with substantially similar terms), the Parties may so agree solely by written instrument signed by both Parties explicitly modifying this Agreement. No waiver will be effective under this Agreement except by a written instrument, expressly identifying the rights waived and signed by the authorized representative of each Person to be bound thereby. A waiver regarding any breach or default will not constitute a waiver with respect to any different or subsequent default unless expressly provided in such waiver instrument. Without limiting the generality of the foregoing, a Party will not be deemed to modify any term or waive any right or remedy under this Agreement by failing to insist on compliance with any of the terms of this Agreement or by failing in one or more instances to exercise any right under this Agreement.

13.6 Remedies. The rights and remedies of the Parties under this Agreement are cumulative, and any Party may enforce any of its rights or remedies under this Agreement or other rights and remedies available to it at law or in equity, except that the Parties will not be entitled to any double recovery. Sun Country and the Sun Country Providers acknowledge that any material breach of this Agreement by Sun Country or the Sun Country Providers would cause Amazon irreparable harm for which Amazon has no adequate remedies at Law. Accordingly, Amazon is entitled to specific performance of this Agreement or injunctive relief for any such breach. Each Party waives all claims for damages by reason of the wrongful issuance of an injunction and acknowledges that their only remedy in that case is the dissolution of that injunction.

13.7 Construction. Each Work Order, addendum, exhibit and schedule associated with this Agreement is hereby incorporated by reference, as if fully set forth herein, and each reference to an exhibit in this Agreement will include all subsections or portions of such exhibit, except that a Work Order or Work Orders may be referenced separately as context requires. If any provision of this Agreement is determined to be unenforceable in any jurisdiction, the Parties intend that this Agreement be enforced in such jurisdiction as if the unenforceable provisions were not present and that any partially valid and enforceable provisions be enforced in such jurisdiction to the extent that they are enforceable, and further agree to substitute for the invalid provision a valid provision (with respect to such jurisdiction) which most closely approximates the intent and economic effect of the invalid provisions. The section headings of this Agreement are for convenience only and have no interpretive value. References to currency or "\$" in this Agreement refer to the United States of America Dollar unless otherwise expressly noted. Unless the context otherwise requires, as used in this Agreement, all terms used in the singular will be deemed to refer to the plural as well, and vice versa. The use of the word "including" and similar terms in this Agreement will be construed without limitation. References in this Agreement to "Business Days" will refer to each day other than a Saturday or Sunday or a day that commercial banking institutions in Seattle, Washington or Eagan, Minnesota are authorized or required by Law to remain closed and "days" means consecutive calendar days. Each Party and its counsel has reviewed and jointly participated in the establishment of this Agreement. No rule of strict construction or presumption that ambiguities will be construed against any drafter will apply. Except as expressly set forth in Sections 13.8 and 13.9, the terms and conditions of this Agreement will apply solely for the benefit of the Parties (including their permitted successors and assigns), and nothing under this Agreement will give any other third party any benefit, right or remedy under this Agreement.

13.8 Third Party Shippers. Amazon may from time to time designate one or more third parties to ship items for, on behalf of, or at the request of Amazon (including items purchased through any e-commerce website operated in whole or in part by Amazon) under this Agreement (a "Third Party Shipper"), with it being understood and agreed that: (a) all Third Party Shipper transactions and accounts will be governed by this Agreement; (b) the terms, conditions, rights, obligations, and rates hereunder will extend to such Third Party Shippers as

beneficiaries hereunder; and (c) upon prior written notice to Sun Country, the Parties will enter into a mutually agreed addendum to this Agreement with respect to a Third Party Shipper. For clarity, any third party in relation to which Amazon has acted as an indirect air carrier with respect to the transportation of items on the Aircraft will not constitute a Third Party Shipper.

13.9 Work Orders. This Agreement governs each Work Order. If any provision of any Work Order conflicts with the terms of this Agreement, then the terms of the Work Order will prevail to the extent necessary to resolve the conflict (but with such modification limited solely to the scope of the Work Order effecting such modification). Amazon and any of its Affiliates will have the right to enter into Carrier Work Orders and Ground Services Work Orders with Sun Country or Sun Country Providers pursuant to this Agreement, and this Agreement will apply to each such Work Order as if the Amazon Affiliate was a signatory to the Agreement. With respect to such Work Orders, such Amazon Affiliate becomes a Party to this Agreement and references to Amazon in this Agreement are deemed to be references to such Affiliate unless otherwise specified. Each Work Order is a separate obligation of the Amazon Affiliate that executes such Work Order, and no other Amazon Affiliate has any liability or obligation under such Work Order. Each Amazon Affiliate receiving Services under this Agreement is an express intended third party beneficiary of this Agreement and will be entitled to enforce this Agreement as if an original signatory hereto. Sun Country will remain jointly and severally responsible for the provision of Services notwithstanding any contracting of Services to any Sun Country Provider or any Work Orders entered into by a Sun Country Provider.

13.10 Hazardous Materials Notifications. Sun Country or the applicable Sun Country Provider will notify Amazon's dangerous goods compliance department (at the phone number or email address designated by Amazon for this purpose) promptly (and in any event within [\*\*\*] hours) after Sun Country or such Sun Country Provider has actual knowledge of or becomes aware in the course of performing the Services of any: (a) injury to persons, property damage, environmental damage, fire, breakage, spillage, leakage, or any other accident or incident involving any product defined, designated, or classified as hazardous material, hazardous substance, or dangerous good (including for clarity, limited and excepted quantities, consumer commodity, ORM-D, lithium batteries, and radioactive and magnetic materials) under any applicable Law and transported or likely to be transported by a Carrier under this Agreement (collectively, "Hazardous Materials"); (b) event or circumstance involving Hazardous Materials that violates or is reasonably likely to violate any applicable Law, or (c) investigation of any shipment containing Hazardous Materials by any Governmental Entity.

13.11 Counterparts. Each Party may effect the execution and delivery of this Agreement and any Work Order, amendment or addendum hereto or thereto by facsimile or electronic transmission (including in portable document format or by electronic signature) of one or more signed counterparts that together will constitute one and the same instrument.

13.12 LIMITATION OF LIABILITIES. Under no circumstances will any Party be liable for any special, incidental, consequential, or indirect damages arising from or in relation to this Agreement, regardless as to the cause of action and however alleged or arising. [\*\*\*].



13.13 Entire Agreement. This Agreement amends and restates the Original Agreement in its entirety. This Agreement, together with the NDA and all other documents referenced in this Agreement (including without limitation any then-effective Work Orders and Aircraft Sublease Agreements), constitutes the complete and final agreement of the parties pertaining to the Services and supersedes the parties' prior agreements, understandings, communications and discussions, oral or written, relating to the subject matter hereof. In the event of a conflict between an Aircraft Sublease and this Agreement solely with respect to which Party is responsible for any costs (including costs in connection with the maintenance, operation and return condition of any Aircraft), expenses, payments, indemnification, or remedies, this Agreement shall prevail to the extent necessary to resolve the conflict. As between the Parties with respect to each Aircraft Sublease: (a) Section 4.6 of each Aircraft Sublease will not apply to any payments made directly to Amazon under the Aircraft Sublease; (b) to the extent a Carrier provides Amazon a Replacement Engine under Section 6.2.2 of an Aircraft Sublease that is in better operating condition and has a better value and utility as the replaced engine (and Amazon has agreed to same in advance), the Parties will mutually agree on reasonable compensation for such incremental value; (c) Amazon will be responsible for the cost of any Heavy Maintenance and Airworthiness Directives that are the responsibility of Amazon pursuant to Sections 2.6.11 or Section 2.6.12 of this Agreement and required so that the Aircraft meets the Return Condition Requirements (as defined in the Aircraft Sublease) (provided that Sun Country will still be responsible to manage or perform such Heavy Maintenance as requested by Amazon) and, if applicable, the incremental, reasonable, documented, out of pocket cost of storing an Aircraft following Return (as defined in the Aircraft Sublease); (d) the Return Condition Requirements of the Aircraft Sublease will be deemed amended to account for any deviations from the Delivery Condition Requirements (as defined in the Aircraft Sublease) approved by Amazon; (e) the following remedies provisions of each Aircraft Sublease will not apply: (i) Sections 16.2.2 and 16.4 (both to the extent relating to costs, expenses and damages); (ii) Sections 16.2.5 (b), (c) (solely to the extent relating to Amazon), (d) and (e); and (iii) Section 16.3; and (f) Amazon will not be entitled to the benefits of an indemnitee under Section 8 of the Aircraft Sublease.

13.14 Cooperation. Each Party will cooperate with the other Party in good faith in the performance of its respective activities contemplated by this Agreement through, among other things, making available, as reasonably requested by the other Party, such management decisions, information, approvals and acceptances in order that the provision of the Services under this Agreement may be accomplished in a proper, timely and efficient manner. Except as expressly provided otherwise, where agreement, approval, acceptance, or consent of a Party is required by any provision of this Agreement, such action will not be unreasonably withheld or delayed.

13.15 Further Assurances. The Parties agree to execute and deliver such other instruments and documents as another Party reasonably requests to evidence or effect the transactions contemplated by this Agreement.

13.16 Priority Over Standard Forms. The Parties may use standard business forms, including bills of lading, waybills, proof of delivery documents and invoices, but use of such forms is for convenience only and does not alter the provisions of this Agreement or any Work Order even if signed by any Party. THE PARTIES WILL BE BOUND BY, AND EACH SPECIFICALLY OBJECTS TO, ANY PROVISION THAT IS DIFFERENT FROM OR IN ADDITION TO THIS AGREEMENT (WHETHER PROFFERED ORALLY OR IN ANY WRITING, INCLUDING ANY QUOTATION, INVOICE, SHIPPING DOCUMENT, BILL OF LADING, WAYBILL, ACCEPTANCE, CONFIRMATION, CORRESPONDENCE, TARIFF, OR CIRCULAR).

[SIGNATURE PAGE IMMEDIATELY FOLLOWS]

AMAZON:

Amazon.com Services, Inc.

By: /s/ Sarah Rhoads

Name: Sarah Rhoads

Title: Vice President

Date Signed: December 14, 2019

Address:

Amazon.com Services, Inc.

Attention: Vice President, Amazon Global Air

(if by USPS):

P.O. Box 81226

Seattle, WA 98108-1226

(if by courier):

410 Terry Avenue North

Seattle, WA 98109-5210

Facsimile: [\*\*\*]

Phone: [\*\*\*]

With a copy to:

Attention: General Counsel

(same P.O. box and courier address)

Email: [contracts-legal@amazon.com](mailto:contracts-legal@amazon.com)

Facsimile: [\*\*\*]

SUN COUNTRY:

Sun Country, Inc.

By: /s/ Jude Bricker

Name: Jude Bricker

Title: Chief Executive Officer

Date Signed: December 13, 2019

Address:

Sun Country, Inc.

Attention: CEO

2005 Cargo Rd

Minneapolis, MN 55450

With a copy to:

Attention: General Counsel

2005 Cargo Rd

Minneapolis, MN 55450

*[Signature Page to Air Transportation Services Agreement]*

**Exhibit A**  
**Committed Aircraft**

<u>Manufacturer</u>	<u>Model Number</u>	<u>Serial Number</u>	<u>Services Commencement Date</u>
1. Boeing	737-800	TBC	[***]
2. Boeing	737-800	TBC	[***]
3. Boeing	737-800	TBC	[***]
4. Boeing	737-800	TBC	[***]
5. Boeing	737-800	TBC	[***]
6. Boeing	737-800	TBC	[***]
7. Boeing	737-800	TBC	[***]
8. Boeing	737-800	TBC	[***]
9. Boeing	737-800	TBC	[***]
10. Boeing	737-800	TBC	[***]

**Exhibit B**  
**Form of Carrier Work Order**

This WORK ORDER No. [●] (this “Work Order”) is effective as of [●] (“Work Order Effective Date”) and entered into and made a part of the Air Transportation Services Agreement between Sun Country, Inc. (“Sun Country”) and Amazon.com Services, Inc. (“Amazon”), effective as of December [●], 2019 (the “Agreement”), to apply to the Amazon entity signatory hereto (solely for the purposes of this Work Order, “Amazon”) and the Carrier entity signatory hereto (solely for the purposes of this Work Order, “Carrier”) for the Services described below. Carrier and Amazon hereto each hereby joins the Agreement with respect to all rights and obligations under this Work Order. Nothing in this Work Order will relieve Amazon or Sun Country of their respective responsibilities for the performance of any obligations under the Agreement. All capitalized terms not defined in this Work Order have the respective meanings set forth in the Agreement. In the event of a conflict between any term in the Agreement and any term in this Work Order, the term in this Work Order will prevail to the extent necessary to resolve the conflict.

1. SUBLEASE OF WORK ORDER AIRCRAFT; PROVISION OF SERVICES

1.1 Carrier and Amazon acknowledge that Amazon and Carrier have entered into an “Aircraft Sublease Agreement (MSN [●]),” dated [●] (the “Aircraft Sublease”), under which Carrier subleases from Amazon one 737-800 aircraft bearing Manufacturer’s Serial Number [●] and Registration Number N[●] (the “Work Order Aircraft”).

1.2 Carrier will operate the Work Order Aircraft in the performance of the cargo flights set forth in the Flight Schedule. The flights described in the Flight Schedule and the other Services performed by Carrier hereunder will, for purposes of this Work Order, be referred to as the “Work Order Services”.

2. EQUIPMENT AND SERVICES; REIMBURSABLE EQUIPMENT AND SERVICES

Carrier will provide, or cause to be provided, the Personnel, capabilities, equipment and other items described in Section 2.5 of the Agreement as needed to provide the Services involving the Work Order Aircraft.

3. COMPENSATION

Compensation for the Work Order Services will be as provided in the Price Schedule and as otherwise specified in the Agreement.

4. CHANGES IN SCOPE; AMENDMENTS TO WORK ORDERS

Any change to Carrier’s scope of Work Order Services under this Work Order must be authorized in writing by both parties, and in the case of Amazon, is binding only if signed by an Amazon Leadership Representative.

5. EFFECTIVENESS AND TERM OF WORK ORDER

This Work Order will be effective upon the Work Order Effective Date and will terminate in accordance with Section 4.5 or 4.7 of the Agreement.

6. ACKNOWLEDGMENT; SUBLEASE

Amazon and Carrier acknowledge and agree that this Work Order will terminate upon the expiration or prior termination of the Aircraft Sublease.

[SIGNATURE PAGE IMMEDIATELY FOLLOWS]

**IN WITNESS WHEREOF**, this Work Order has been duly executed and delivered by duly authorized officers of the Parties on the date first written above.

AMAZON:  
Amazon.com Services, Inc.

By: \_\_\_\_\_  
Name: \_\_\_\_\_  
Title: \_\_\_\_\_  
Date Signed: \_\_\_\_\_

Address:

Amazon.com Services, Inc.  
Attention: Vice President, Amazon Global Air  
(if by USPS):  
P.O. Box 81226  
Seattle, WA 98108-1226  
(if by courier):  
410 Terry Avenue North  
Seattle, WA 98109-5210  
Facsimile: [\*\*\*]  
Phone: [\*\*\*]

With a copy to:

Attention: General Counsel  
(same P.O. box and courier address)  
Email: [contracts-legal@amazon.com](mailto:contracts-legal@amazon.com)  
Facsimile: [\*\*\*]

CARRIER:  
Sun Country, Inc.

By: \_\_\_\_\_  
Name: \_\_\_\_\_  
Title: \_\_\_\_\_  
Date Signed: \_\_\_\_\_

Address:

Sun Country, Inc.  
Attention: CEO  
2005 Cargo Rd  
Minneapolis, MN 55450

With a copy to:

Attention: General Counsel  
2005 Cargo Rd  
Minneapolis, MN 55450

**Exhibit C**  
**Performance Standards**

1. Services.

- 1.1 The Carrier will meet the flight availability commitments set forth in the Flight Schedule.
- 1.2 The Carrier will in no circumstances alter any information on the label provided by Amazon on any package provided by Amazon or any third party for shipment as part of the Services.

2. Reports and Electronic Communications. The Carrier will provide daily electronic reports including (a) performance and exception reports, (b) electronic summary reports itemizing volume on a periodic basis determined by Amazon, (c) such other reports described in this Agreement and (d) such other reports reasonably requested by Amazon, in the formats Amazon provides.

3. Service Disruption. If the Carrier experiences any material stoppage or disruption that generally diminishes its capacity to transport and deliver parcels, it will allocate its remaining available cargo capacity to Amazon's account on terms no less favorable than those granted to any other of the Carrier's customers.

4. Arrival Performance Incentive/Disincentive.

- 4.1 Amazon will pay to Sun Country a monthly financial incentive bonus (the "Monthly Incentive Bonus") for achieving an Arrival Performance (as defined in the following paragraph) greater than or equal to [\*\*\*] during such month. Alternatively, Sun Country will provide Amazon with a credit (the "Monthly Disincentive Credit") against amounts owed by Amazon to Sun Country hereunder as a financial disincentive for achieving an Arrival Performance less than [\*\*\*] during such month. The Monthly Incentive Bonus and the Monthly Disincentive Credit to which Sun Country may be entitled or subject to each month, are set forth in the table below. For clarity, payment to Sun Country of a Monthly Incentive Bonus or Monthly Disincentive Credit will not cure a Sun Country or Carrier Event of Default. [\*\*\*]
- 4.2 For purposes of this Agreement and the Carrier Work Orders, including for the purpose of determining the Monthly Incentive Bonus and the Monthly Disincentive Credit under this Agreement, the term "Arrival Performance" means, the percentage of all flights flown in performing the Services under this Agreement (including cancelled flights due to Carrier Delay but excluding cancelled flights relating to delayed implementation of an amended Flight Schedule for which a payment was made under Section 2.10.2), in any given calendar month which arrive within not more than [\*\*\*] whole minutes after the scheduled arrival time for each flight. If a secondary flight (*i.e.*, any flight leg in a rotation subsequent to the initial flight leg) is delayed following earlier delayed flight leg(s) in the same rotation in the prior [\*\*\*] hour period, the scheduled arrival time of the delayed secondary



flight will be deemed to be extended by the length of the delay(s) that were experienced by such prior flight legs within the rotation, except that if the period between: (a) a flight's actual arrival time and the next departure time for the Aircraft as reflected on the Flight Schedule exceeds [\*\*\*] minutes; or (b) the arrival time and the departure time for the Aircraft's next flight as reflected on the Flight Schedule exceeds [\*\*\*] hours, then delays from prior flight legs will not be taken into account and there will be no such deemed extension.

- 4.3 In determining whether a flight has arrived within not more than [\*\*\*] whole minutes after its scheduled arrival time, (a) only delays that are attributable to circumstances that are within the reasonable control of the Carrier will be taken into account, including: (i) the mechanical breakdown of an Aircraft, (ii) the unavailability of an Aircraft due to regular scheduled maintenance, (iii) the acts or omissions of a Flight Crew (except with respect to actions required for safety, security, or compliance with Law), (iv) the unavailability of an Aircraft and (v) flight planning, flight following or dispatch issues (collectively, "Carrier Delays"); and (b) no flight directly affected by Force Majeure will be deemed to be delayed to the extent the delay is caused by Force Majeure, regardless of its arrival time. Notwithstanding the foregoing, the delay codes labeled as Carrier Controllable in the below table are presumed to represent delay situations that are within the reasonable control of a Carrier. For clarity, although the table is intended to be comprehensive, it may not cover all circumstances that could give rise to delays that are within the reasonable control of a Carrier.

**DELAY CODE TABLE**

<b>Amazon Delay Code</b>	<b>Description / Root Cause</b>	<b>[***]</b>
4	Amazon Permits	[***]
6	Amazon Late Inbound Line haul	[***]
8	Amazon Requested Schedule Change	[***]
11	Aircraft Maintenance Docs Late/Inaccurate	[***]
19	Amazon Requested Delay for Connecting Cargo	[***]
20	Cargo/Ground/Ramp Delay	[***]
21	Ground Documentation, Errors, etc.	[***]
24	Inadequate Parking	[***]
26	Late Preparation in Warehouse/Late Sort	[***]

Amazon Delay Code	Description / Root Cause	[**]
29	Crew Notification/Transport	[**]
32	Loading/Unloading	[**]
33	Ground Service Equipment	[**]
34	Servicing Equipment	[**]
35	Exterior Aircraft Cleaning	[**]
36	Fueling/Defueling	[**]
37	Catering	[**]
38	ULD/Pallets (e.g., nets, straps, etc.)	[**]
41	Aircraft Defects	[**]
42	Scheduled Maintenance Late Release	[**]
43	Technical Manpower Resources	[**]
44	Maintenance Materials and Equipment	[**]
46	Aircraft Change	[**]
47	Maintenance Block Turn Back	[**]
51	Foreign object damage to aircraft—non ground (e.g., birdstrike)	[**]
52	Damage During Ground Ops	[**]
56	Crew Positioning on Company Aircraft	[**]
57	Flight Plans/Paperwork Transmission Failure	[**]
58	Crew Fatigue	[**]
59	Travel between Hotel and Airport	[**]
60	Flight Ops Delay	[**]
63	Late Crew Boarding	[**]

Amazon Delay Code	Description / Root Cause	***
64	Crew Medical	***
65	Flight Deck Crew Special Request	***
66	Crew Rest Due to FAA Restriction	***
67	Crew Rest due to Late Arrival attributable to Carrier Delay	***
68	Crew Scheduling	***
69	Crew Positioning on Commercial Aircraft	***
71	Departure Station Weather	***
72	Destination Station Weather	***
73	Enroute or Alternate Weather	***
75	De-Icing of Aircraft	***
76	Removal of Snow, Ice, Water, Sand from Runway	***
77	Ground Handling Impaired by WX Conditions	***
80	ATC/Apt/Govt Delay	***
81	ATC Enroute Demand/Capacity	***
82	Carrier Permits	***
85	Mandatory Security	***
86	Immigration/Customs/Health/FAA	***
87	No Gate/Stand Available Due to Airline Activity	***
88	Congestion/Restrictions at Departure Airport	***
89	Congestion/Restrictions at Arrival Airport	***
94	Gateway Rotational Delay	***
97	Industrial Action Within Own Airline	***
98	Industrial Action Outside Own Airline	***

4.4 The Monthly Incentive Bonus or Monthly Disincentive Credit will be reflected by Sun Country on the Monthly Invoice provided in accordance with this Exhibit C for the calendar month in which the incentive or credit has been calculated.

ARRIVAL PERFORMANCE INCENTIVE/DISINCENTIVE TABLE

Monthly Network Arrival Performance	Monthly Bonus/Penalty Amount*	Monthly Bonus/Penalty Credited to
<sup>3</sup> [***]%	\$ [***]	
<sup>3</sup> [***]% < [***]%	\$ [***]	Sun Country
<sup>3</sup> [***]% < [***]%	\$ [***]	
<sup>3</sup> [***]% < [***]%	\$ [***]	
<sup>3</sup> [***]% < [***]%	\$ [***]	NA
<sup>3</sup> [***]% < [***]%	-\$ [***]	
<sup>3</sup> [***]% < [***]%	-\$ [***]	Amazon
< [***]%	-\$ [***]	

\* Based on [\*\*\*] operating Aircraft.

**Exhibit D**  
**Invoices; Payments; Deposits; Weekly Statement**

1. Invoices. Sun Country will provide monthly electronic invoices to Amazon as set forth in this Exhibit D. Each such invoice will reflect the relevant charges due from Amazon to Sun Country for the relevant period on a consolidated basis for Sun Country and all Sun Country Providers providing Services under the Agreement during that period.
2. Monthly Deposits by Amazon. On or before the [\*\*\*] day of each month (or the subsequent business day if the [\*\*\*] is not a business day) during which Services are provided under the Agreement, Amazon will provide to Sun Country, without demand, [\*\*\*] of the total expected amount due to Sun Country for the month set forth in the Price Schedule then in effect (including estimated fuel reimbursements per Section 2.6 of the Agreement). With respect to Network Spares, Amazon will pay [\*\*\*]% of the applicable Fixed Monthly Costs listed in the Price Schedule for each Network Spare but no assumed usage will apply.
3. Weekly Activity Statements Provided by Sun Country. Sun Country will provide to Amazon a weekly statement of activity under the Agreement (a "Weekly Activity Statement") within [\*\*\*] Business Days following the end of the preceding week to the extent Services were performed during the preceding week under the Work Order. Each such Weekly Activity Statement will contain an identification of the flights performed, the date of performance, the Carrier and Amazon reference identification numbers, and flight origin and destination, reflecting the number of Block Hours and Flight Cycles actually flown by all Carriers under this Agreement during the previous calendar week.
4. Monthly Invoice; Reconciliation. Within [\*\*\*] Business Days following the end of each calendar month during which Services are provided under the Agreement, Sun Country will provide to Amazon an invoice with respect to the preceding calendar month (a "Monthly Invoice") reflecting the following with respect to the preceding month.
  - (a) Reconciliation of Fixed Monthly Charge. A statement reconciling (1) the amount of the estimated Fixed Monthly Charge deposited with Sun Country under the monthly deposit during the preceding calendar month with (2) the Fixed Monthly Charge actually payable under the Agreement for the preceding calendar month, together with a statement of any additional amount due from Amazon to Sun Country or any credit due from Sun Country to Amazon as a result of that reconciliation;
  - (b) Reconciliation of Variable Charges. A statement reconciling (1) the amount of the estimated Variable Charges deposited with Sun Country under the monthly deposit during the preceding calendar month with (2) the actual Variable Charges payable by Amazon under the Agreement for the preceding calendar month, together with a statement of any additional amount due from Amazon to Sun Country or any credit due from Sun Country to Amazon as a result of that reconciliation;

- (c) Reconciliation of Fuel Charges. A statement reconciling (1) the amount of the estimated fuel charges deposited with Sun Country under the monthly deposit during the preceding calendar month with (2) the actual fuel charges payable by Amazon under the Agreement for the preceding calendar month, together with a statement of any additional amount due from Amazon to Sun Country or any credit due from Sun Country to Amazon as a result of that reconciliation;
- (d) Reconciliation of Aircraft Sublease Rent. A statement reconciling (1) the amount of reimbursable rent under the Aircraft Subleases deposited with Sun Country under the monthly deposit during the preceding calendar month with (2) the actual amount of rent reimbursable under the Aircraft Subleases for the preceding calendar month, together with a statement of any additional amount due from Amazon to Sun Country or any credit due from Sun Country to Amazon as a result of that reconciliation;
- (e) Reconciliation of Maintenance Fuel. A statement reconciling the Maintenance Fuel used during the preceding calendar month including details of the dates, locations and applicable APU and/or engine hours when Maintenance Fuel was used.
- (f) Performance Incentive or Disincentive. A statement showing the calculation of the Arrival Performance achieved by the Carriers under the Agreement during the preceding calendar month covered by the Monthly Invoice together with a statement of the Monthly Incentive Bonus or Monthly Disincentive Credit, if any, payable or due with respect to the preceding calendar month;
- (g) Other Amounts Payable or Reimbursable. A statement of any other amounts payable or reimbursable by Amazon to Sun Country or creditable from Sun Country to Amazon under the Agreement; and
- (h) Amount Payable or Credit Due. A statement of the sum total amount due from Amazon to Sun Country or the total credit due from Sun Country to Amazon with the Monthly Invoice.

5. Payment of Monthly Invoice. If the Monthly Invoice shows a sum total amount payable by Amazon to Sun Country, that amount will be paid within [\*\*\*] days following Amazon's receipt of the Monthly Invoice. If the Monthly Invoice shows a sum credit due to Amazon from Sun Country, that credit will be applied first against any amount then remaining unpaid under any Monthly Invoice, from oldest to newest, and then against the Fixed Monthly Charge next payable by Amazon to Sun Country hereunder.

6. Invoice Data. Sun Country will provide each Monthly Invoice in a manner that complies with all requirements of applicable tax laws and accounting standards and which, together with the Weekly Activity Statements and supporting documentation for the calendar month covered by that invoice, provides sufficient information for Amazon to determine the accuracy of the amounts invoiced thereon. Sun Country and the Carriers will retain copies of relevant documentation supporting the invoiced amounts for a period of [\*\*\*] years from the date of the Monthly Invoice to which such documentation relates and, during that [\*\*\*] year period, Amazon may inspect and audit such documentation upon request to Sun Country.

7. Segregating Accounts. At Amazon's election from time to time, Sun Country will promptly create separate accounts and issue separate invoices for Amazon and each Amazon Affiliate for which it provides Services and, to the extent applicable, each Third Party Shipper. The payment obligation under each such separate account and invoice is a separate obligation solely of Amazon, the Amazon Affiliate, or the Third Party Shipper as applicable, to which the invoiced Services were provided, and no other Person will have any obligation with respect to such account or under such invoice

8. Payment; Disputes. Amazon will pay undisputed portions of Sun Country's properly submitted invoices within [\*\*\*] days of receipt of the relevant invoice. Disputed invoices, payments, credits or other amounts will be rejected, challenged or short paid (as applicable) with appropriate explanation of the discrepancy. In the event that any invoice, payment, credit or other amount is reasonably disputed, the disputing Party will notify the other Party of such dispute on or before the date that such invoice, payment or credit is due to be paid or issued (the "Disputed Notice Date"). The notification of a dispute will not relieve the disputing Party of its obligations with respect to any non-disputed amounts. As soon as possible after receipt of notification of a dispute, the Parties will convene their responsible managers in order to resolve such dispute in good faith and through the application of reasonable commercial efforts. In the event that the responsible managers are unable to resolve such dispute within [\*\*\*] days after the Disputed Notice Date (in which case the settled amount will be paid within [\*\*\*] days of such resolution), then such dispute will be escalated to an Amazon Leadership Representative and the CFO of Sun Country for resolution. In the event that the Amazon Leadership Representative and CFO of Sun Country are unable to resolve the dispute or the disputing Party has not paid the disputed amount within [\*\*\*] days after the Disputed Notice Date (in which case the settled amount will be paid within [\*\*\*] days of such resolution), then the Parties may pursue their respective rights in accordance with Section 13.3 of the Agreement. Sun Country and each Carrier will be entitled to refuse to pick up any further parcels under Work Orders if Amazon fails to cure any payment default (which default, for clarity, does not include non-payment of a disputed invoice, payment, credit or other amount) within [\*\*\*] Business Days after receiving written notice of such delinquency, except that Sun Country and each Sun Country Provider will: (A) continue to provide Services under the Agreement and Work Orders through the notice period; and (B) deliver all parcels that have been picked up through such notice period. Notwithstanding the foregoing, Amazon has no obligation to pay any fees or expenses invoiced more than [\*\*\*] months after the relevant Service was performed, except that the deadline for individual expenses will be extended to [\*\*\*] (or, in the event of contested invoices, such later period as reasonably approved by Amazon) if: (a) the expense was for a third party reimbursable expense; (b) the delay is solely due to the actions of the third party and not reasonably avoidable by a Sun Country Provider; and (c) Sun Country gives reasonable notice to Amazon of the delayed invoice from the third party.

9. In all cases, payments to Sun Country will be made in U.S. Dollars and will be sent at Amazon's expense via irrevocable wire transfer in immediately available funds to the following account:

10. Interest on Overdue Amounts. Any payment or credit not made when due will bear interest at a rate equal to the 3-month LIBOR plus [\*\*\*] percent, from the date which is [\*\*\*] Business Days after the Party that owes the past due payment or credit receives written notice thereof until Sun Country or Amazon receives the applicable payment or credit, as applicable.



---

**Exhibit E**  
**Form of Aircraft Sublease Agreement**  
[Included on the following pages]

E-1

**AIRCRAFT SUBLEASE AGREEMENT  
(MSN [●])**

BETWEEN

AMAZON.COM SERVICES LLC,

AS SUBLESSOR

AND

SUN COUNTRY, INC.,

AS SUBLESSEE

RELATING TO ONE BOEING MODEL 737-800 AIRCRAFT

SERIAL NUMBER [●]

U.S. REGISTRATION NO. N [●]

TO THE EXTENT THAT THIS AIRCRAFT SUBLEASE AGREEMENT CONSTITUTES CHATTEL PAPER (AS DEFINED IN THE UNIFORM COMMERCIAL CODE AS IN EFFECT IN ANY APPLICABLE JURISDICTION), NO SECURITY INTEREST IN THIS AIRCRAFT SUBLEASE AGREEMENT MAY BE CREATED THROUGH TRANSFER OR POSSESSION OF ANY COUNTERPART OTHER THAN THE ORIGINAL COUNTERPART, WHICH SHALL BE IDENTIFIED AS THE COUNTERPART DESIGNATED AS THE ORIGINAL ON THE SIGNATURE PAGE OF THIS AIRCRAFT SUBLEASE AGREEMENT BY HEAD LESSOR.

E-2

## TABLE OF CONTENTS

<b>1. Definitions</b>	<b>8</b>
<b>2. Conditions Precedent</b>	<b>19</b>
2.1 Sublessor's Conditions Precedent	19
2.2 Sublessee's Conditions Precedent	20
<b>3. Sublease of Aircraft; Inspection; Technical Acceptance; Delivery</b>	<b>21</b>
3.1 Sublease of the Aircraft	21
3.2 Term	21
3.3 Anticipated Delivery Month	21
3.4 A Lease Only, Section 1110	21
3.5 Delivery	21
3.6 Condition of the Aircraft; Modifications	21
3.7 Inspection	21
3.8 Technical Acceptance	22
3.9 Modifications	22
<b>4. Payments; Method of Payment</b>	<b>22</b>
4.1 [Reserved]	22
4.2 Basic Rent	22
4.3 Basic Rent Payments	23
4.4 Due Date Not on Business Day	23
4.5 No Abatement	23
4.6 Interest on Overdue Amounts	23
<b>5. Registration; Nameplates; Filings</b>	<b>23</b>
5.1 Registration	23
5.2 Nameplates	24
5.3 Filings	24
<b>6. Possession, Use and Operation of the Aircraft; Risk of Loss or Damage</b>	<b>24</b>
6.1 Possession of Aircraft; Operations	24
6.2 Possession of Engines and Parts	26
6.3 Pooling of Parts	28
6.5 Commercial Operations	29
6.6 Lawful and Safe Operations	29
6.7 Maintenance	30
6.8 Net Lease	30
6.9 Risk of Loss or Damage	32
6.10 Subordination	32

<b>7. Maintenance and Modifications</b>	<b>32</b>
7.1 Maintenance of the Aircraft; ADs	32
7.2 Maintenance of the Aircraft Documents	33
7.3 Authorized Maintenance Provider	33
7.4 Equipment Changes	33
7.5 Summary of Flight Hours, Cycles; Technical Information	34
7.6 Access; Inspections	35
<b>8. Taxes.</b>	<b>36</b>
8.1 General:	36
8.2 Sales and Use Taxes:	37
8.3 Sublessor Taxes	38
8.4 Tax Contest	39
8.5 Sublessee's Indemnities Payable on After-Tax Basis; Payments in Respect of Tax Benefits	42
8.6 Payment of Tax	42
8.7 Tax Exemptions, Rebates, and Credits	42
8.8 Withholding and Tax Credit	42
8.9 Value Added Tax	43
<b>9. Liens</b>	<b>44</b>
9.1 Permitted Liens	44
9.2 Other Liens	44
<b>10. Indemnification</b>	<b>45</b>
10.1 GENERAL INDEMNITY	45
10.2 Exceptions	45
10.3 Continuance	46
<b>11. Insurance</b>	<b>46</b>
11.1 Aviation Third Party Legal Liability Insurance	46
11.2 Aircraft Hull Insurance	47
11.3 Spares Insurance	50
11.4 Default	50
11.5 Certificates	50
11.6 Reinsurance	50
11.7 Premiums	51
11.8 Claims	51
11.9 Application of Payments During Continuation of an Event of Default	51
11.10 Maintenance	52
11.11 Insurance Undertakings and Information	52
<b>12. Assignment</b>	<b>53</b>
12.1 Assignment by Sublessee	53
12.2 Assignment by Sublessor	53
12.3 Assignment of Sublease	53
12.4 Assignment of Warranties	53

<b>13. “As-Is” Condition, Disclaimer and Release</b>	<b>54</b>
13.1 DISCLAIMER	54
13.2 ACKNOWLEDGEMENT	55
13.3 Waiver	56
<b>14. Representations and Warranties</b>	<b>56</b>
14.1 Sublessee’s Representations and Warranties	56
14.2 Sublessor’s Representations and Warranties	58
<b>15. Covenants</b>	<b>59</b>
15.1 Sublessee’s Covenants	59
15.2 Sublessor’s Covenants	62
<b>16. Default; Remedies</b>	<b>63</b>
16.1 Events of Default	63
16.2 Remedies	64
16.3 Costs and Expenses; Default Indemnity	66
16.4 International Interests	66
16.5 Waiver of Defenses to Repossession	66
<b>17. Return of Aircraft</b>	<b>67</b>
17.1 Return, Place and Time of Return	67
17.2 Aircraft Return Condition Requirements	68
17.3 Return Receipt	68
17.4 Specific Performance	68
17.5 Sublessee’s Obligations Continue	68
<b>18. Return Condition Requirements</b>	<b>68</b>
18.1 Return	68
18.2 Non-Compliance	69
<b>19. Total Loss</b>	<b>70</b>
19.1 Total Loss of the Aircraft	70
19.2 Requisition	70
<b>20. Miscellaneous</b>	<b>71</b>
20.1 Entire Agreement	71
20.2 Illegality; Severability	71
20.3 Amendment and Waiver	71
20.4 Governing Law; Jurisdiction; WAIVER OF JURY TRIAL	71
20.5 Legal Costs and Expenses	73
20.6 DISCLAIMER OF DAMAGES	74
20.7 Further Assurances	74
20.8 Notices	74
20.9 Counterparts	75
20.10 Brokers	75

---

20.11 Financing Parties	76
20.12 Early Termination Option	76
20.13 Construction	76
20.14 Cooperation	77

---

Appendix A: Description of Airframe and Engines

Appendix B: Particular Commercial Conditions

Appendix C: [Reserved]

Appendix D: Form of Technical Acceptance Certificate

Appendix E: Form of Sublease Supplement

Appendix F: Return Receipt

Appendix G: Delivery Conditions

Appendix H: Return Condition Requirements

Appendix I: Cargo Aircraft Cabin Interior Standard

# AIRCRAFT SUBLEASE AGREEMENT

(MSN [●])

**THIS AIRCRAFT SUBLEASE AGREEMENT (MSN [●])** (this “Agreement”), dated and effective on [●], 2020 (the “Effective Date”), is between Amazon.com Services LLC, a Delaware limited liability company (“Sublessor”), and Sun Country, Inc., a Minnesota corporation (“Sublessee”).

## RECITALS

Sublessor and Sublessee entered into an Air Transportation Services Agreement dated December 10, 2019 (“ATSA”), pursuant to which Sublessor has agreed to sublease certain aircraft to Sublessee for Sublessee’s use in providing air cargo transportation services to Sublessor;

Sublessee desires to sublease the “Aircraft” (as defined in Section 1) from Sublessor; and

Sublessor is agreeable to subleasing the Aircraft to Sublessee, upon and subject to the terms and conditions of this Agreement.

In consideration of the premises, and of the representations, warranties, covenants, and agreements set forth herein, and intending to be legally bound, the Parties agree as set forth herein:

## AGREEMENT

### 1. Definitions.

“AD Compliance Period” means, for ADs with clearance of [\*\*\*] days or the equivalent flight hours and cycles and in the case of Engine fan blades with more than [\*\*\*]cycles since new, the fan blade dovetail ultrasonic inspection per SB 72-1033 or eddy current inspection per ESM will have been performed no more than [\*\*\*]cycles prior to Delivery

“Additional Insured” is defined in Section 11.1.

“ADs” means any airworthiness directive or comparable document issued by the Aviation Authority affecting the Airframe, the Engines, the APU, or the Parts.

“Affiliate” means, with respect to a specified entity, any other entity that, directly or indirectly, controls, is controlled by, or is under common control with such specified entity, where “control” means the possession, direct or indirect, of the power to direct or cause the direction of the management and policies of an entity, whether through the ownership of voting securities, or otherwise.

“Agreed Value” means the value specified as such in Appendix B and is defined in the London insurance market in relation to aviation hull policies.

“Aircraft” means, collectively, the Airframe, the Engines, the APU, the Parts, and the Aircraft Documents.



“Aircraft Condition Damages” means, collectively, any loss, cost, expense or liability, or damage to Sublessor’s residual interest in the Aircraft, sustained by Sublessor due to Sublessee’s failure to maintain the Aircraft in accordance with the terms of the Sublease or Sublessee’s failure to redeliver the Aircraft in conformity with the Return Condition Requirements, including any consequential loss of revenues or profits.

“Aircraft Documents” means the documents, data and records identified in the list attached to the Certificate of Acceptance, and any other documents and records required in connection with Sublessee’s obligations under Section 7.2, and all additions, renewals, revisions and replacements from time to time made to any of the foregoing in accordance with the Sublease. The term is not limited to paper forms; documents and records may be in digital, hard copy or other form, provided they conform with applicable Regulations and customary practice in the commercial aviation industry from time to time.

“Aircraft Specific Lease Agreement” means the Aircraft Specific Lease Agreement dated as of [●] between the Head Lessor, as lessor and the Sublessor, as lessee.

“Airframe” means the Boeing model 737-83N airframe described in Appendix A, together with all Parts, excluding, however, the Engines or any other engines from time to time installed on the Aircraft, but including each QEC.

“Airframe Structural Check” means a heavy maintenance visit which shall include (a) all 8 year inspections (whether their interval is in Flight Hours, Cycles, calendar or a combination of all three measures), including all lesser multiple inspections, ISIP/CPCP items and refurbishment of the main cargo deck including the cargo loading system; and (b) all 12 year structural inspections.

“Anticipated Delivery Month” means [●], 2020, which is the date that the Parties anticipate that the Aircraft will be delivered to Sublessee pursuant to the terms and conditions of this Agreement.

“APU” means the auxiliary power unit installed on the Aircraft on the Delivery Date and any replacement auxiliary power unit installed on the Aircraft and title to which is transferred to Head Lessor in accordance with the Head Lease.

“APU Hours” means each hour or part thereof that an APU is operated, elapsing from the moment the APU is started until it is shut down.

“ATSA” is defined in the recitals.

“Authorized Maintenance Provider” means any repair station licensed or certified by the Aviation Authority (and, if different the FAA or EASA) acting within the scope of its authorization.

“Aviation Authority” means the FAA and any other Governmental Entity having jurisdiction over the Aircraft and this Agreement or Sublessee’s (or any other operator of the Aircraft’s) operations, and any successors thereto, respectively (with the understanding that, should the Aircraft be registered in a country other than the United States, this definition will include all Governmental Entities outside of the United States with jurisdiction over the Aircraft).

“Basic Rent” means the amount specified in Appendix B and payable in accordance with Sections 4.2.1 and 4.3.

“Basic Rent Date” means the Delivery Date and the first day of each calendar month after the Delivery Date until the Return Date.

“Business Day” is defined in Section 20.13.

“Cape Town Convention” means the Convention on International Interests in Mobile Equipment and its Protocol on Matters Specific to Aircraft Equipment, concluded in Cape Town, South Africa, on November 16, 2001.

“Certificated Air Carrier” means any Person (except the United States government) that is a Citizen of the United States and holds a Certificate of Public Convenience and Necessity issued under Section 41102 of Title 49 of the United States Code by the United States Department of Transportation or any predecessor or successor agency thereto, and an air carrier operating certificate issued pursuant to Chapter 447 of Title 49 of the United States Code or, in the event such certificates are no longer applicable, any Person (except the United States government) that is a Citizen of the United States and legally engaged in the business of transporting for hire passengers or cargo by air predominantly to, from or between points within the United States, and, in either event, operating commercial jet aircraft capable of carrying ten or more individuals or 6,000 pounds or more of cargo, which also is certificated so as to entitle Sublessor, as lessor, to the benefits of Title 11 of the United States Code with respect to Aircraft.

“Citizen of the United States” is defined in Section 40102(a)(15) of Title 49 of the United States Code or any similar legislation of the United States enacted in substitution or replacement thereof.

“Code” means the Internal Revenue Code of 1986, as amended.

“Common Terms Agreement” means the Aircraft Lease Common Terms Agreement between [\*\*\*] and the Sublessor.

“CRAF Program” is defined in Section 6.1.2.

“Cycle” means one take-off and the next subsequent landing of the Aircraft.

“Damage Notification Threshold” is defined in Appendix B.

“days” is defined in Section 20.13.

“Default” means any event which, with the giving of notice, lapse of time, or both, would become an Event of Default.

“Delivery” is defined in Section 3.5.

“Delivery Condition Requirements” is defined in Section 3.6.1.

“Delivery Date” means the date on which the Delivery occurs.

“Delivery Location” means [●] or such other location as may be mutually agreed by the Parties in writing.

“Discount Rate” means a rate equal to [\*\*\*]% per annum.

“Discrepancy” means any non-conformity with the Delivery Condition Requirements notified by Sublessee to Sublessor during the Pre-Delivery Procedure.

“Dollars” means United States Dollars.

“Early Termination Date” is defined in Section 20.12.

“EASA” means the European Aviation Safety Agency and all successors thereto.

“Effective Date” is defined in the Preamble.

“Enforcement and Remarketing Costs” means, collectively, all costs, expenses and other incidental damages and losses associated with Sublessor’s exercise of its remedies under the Sublease or otherwise incurred by Sublessor as a result of an Event of Default or the exercise of rights or remedies with respect thereto, including repossession costs, reasonable legal fees, Aircraft storage, preservation, shipment, repair, refurbishment, modification, maintenance and insurance costs, Aircraft re-lease or sale costs (including any costs incurred to prepare the Aircraft for sale or lease, advertising costs, sale or lease costs (including commissions) and any costs to transition the Aircraft to the next operator’s maintenance program provided that such transition costs will be limited to items reasonably required to place the Aircraft on the next operator’s operations specifications) in any way related to the Aircraft, any Engine or any Part, to the extent necessary to conform the Aircraft with the Return Condition Requirements or in the location provided for in Section 16.2, or otherwise, but excluding Sublessor’s internal costs and expenses (such as the cost of personnel time calculated based upon the compensation paid to the individuals involved on an annual basis or a general Sublessor overhead allocation).

“Engine” means (a) either of the two engines identified as to manufacturer and type and by serial number on the Sublease Supplement (each of which will have more than 1750 pounds of thrust or its equivalent), together with all Parts installed on the engine, and any engine substituted for an Engine pursuant to the terms of this Agreement and (b) any engine that becomes an Engine from time to time under this Sublease.

“Engine Build Standard” means the minimum release life of an Engine following an Engine Refurbishment as mutually agreed between Sublessor and Sublessee, but in no event will such Engine be required to have a minimum release life longer than the release life to match Sublessor’s expected mean time between removals.

“Engine Module Refurbishment” means, with respect to any Engine, the visual inspection and repair as necessary in accordance with the Manufacturer’s maintenance planning document and engine shop manual of any module of such Engine occurring during an Engine Refurbishment event including, but not limited to, de-blading of rotors and inspection of blades in accordance with engine shop manual piece part level criteria.

“Engine Refurbishment” means, with respect to any Engine, all necessary maintenance, inspection, overhaul and repair work (accomplished by a maintenance performer, acceptable to Sublessor, at an engine repair/overhaul station) of certain modules of that Engine as is required from time to time to restore its performance, in accordance with the performance restoration or overhaul sections of the Manufacturer’s shop maintenance planning document and engine shop manual for that particular engine model and type, taking account of any specific build or performance standards set out in the Sublease. In addition, the workscope shall ensure that: (i) expected life of the Engine hardware and expected life of each engine module matches the specific Engine Build Standard; and (ii) the items mentioned in the definition of Engine Module Refurbishment are carried out.

“Engine Thrust Setting” means the figure corresponding to such term set forth in Appendix G.

“Engine Total Loss” means the occurrence, with respect to an Engine only, whether or not installed on the Airframe, of any of those events described in the definition of Total Loss.

“Environmental Laws” means all air quality, climate change, waste management and other environmental protection Laws and all related implementing Laws.

“Equipment Change” is defined in Section 7.4.

“ERISA” means the Employee Retirement Income Security Act of 1974, as amended.

“Event of Default” means any one of the events specified in Section 16.1.1.

“Expiration” means the end of the Term by reaching the Expiration Date or as a result of a Termination.

“Expiration Date” means the date [\*\*\*] months from the Delivery Date, or, as applicable, the Expiration date.

“Extended Term” means an extension of the Term due to: (a) Sublessee’s failure to Return the Aircraft in compliance with the Return Condition Requirements on the Expiration of the Agreement as further described in Section 17.5; or (b) a requisition of the Aircraft as further described in Section 6.9.

“Extended Term Rent” means the amount specified in Appendix B and payable in accordance with Section 18.2.3.

“FAA” means the United States Federal Aviation Administration and all successors thereto.

“FAR” means the Federal Aviation Regulations issued by the FAA, as same may be amended, modified, restated, or replaced from time to time.

“Final Inspection” is defined in Appendix H.

“Financing Documents” has the meaning given to such term in the Head Lease.

“Financing Parties’ Representative” means, at any time, any Person then representing the Financing Parties as agent trustee, secured party, security trustee, or in another similar capacity and its and their successors and assigns, including each such Person that Head Lessor or Sublessor from time to time notifies to Sublessee as being the Financing Parties’ Representative.

“Financing Party” has the meaning given to such term in the Head Lease.

“Flight Hours” means, with respect to the Aircraft, the time as measured in hours and minutes elapsing from the moment at which the wheels of the Aircraft leave the ground on a takeoff until the wheels of the Aircraft touch the ground on the next landing of the Aircraft.

[\*\*\*]

“Geneva Convention” means the Convention for the International Recognition of Rights in Aircraft, signed (ad referendum) at Geneva, Switzerland, on June 19, 1948, and amended from time to time, but excluding the terms of any adhesion thereto or ratification thereof containing reservations to which the United States of America does not accede.

“Governmental Entity” means: (a) any national government, any political subdivision thereof, or local authority therein, whether foreign or domestic; (b) any agency, board, commission, department, division, organ, instrumentality, or court of any of the foregoing, however constituted; and (c) any organization, association, or institution, of which any of the foregoing is a member or to whose jurisdiction it is subject or in whose activities it is a participant.

“Habitual Base” means the United States or, subject to the prior written consent of Sublessor, any other country or countries in which the Aircraft is for the time being habitually based.

“Head Lease” means the Aircraft Specific Lease Agreement, incorporating by reference the terms of the Common Terms Agreement.

“Head Lease Servicer” means [\*\*\*] or as notified by Sublessor or Head Lessor in writing from time to time.

“Head Lessor” means Bank of Utah, not in its individual capacity, except as expressly provided in the Head Lease, but solely as Owner Trustee.

“Head Lessor Parent” means each Person that from time to time is the legal or beneficial owner, directly or indirectly, of the capital stock, membership interests, beneficial interests, partnership interests or other interests of or in Head Lessor or Owner Participant, provided, that the term Head Lessor Parent shall not include any public shareholders of the [\*\*\*].

“Illegality Date” is defined in Section 20.2.1.

“Indemnitees” means each of Head Lessor, Owner Participant, Head Lessor Parent, Head Lease Servicer, [\*\*\*], Trust Company, any Financing Parties, and their respective successors and permitted assigns, and each of their respective shareholders, subsidiaries, Affiliates, members, beneficial interest holders, trustees, partners, contractors, directors, officers, representatives, servants, agents and employees and in the case of any trustee, such institution in its individual capacity acting as such, provided that the term “Indemnitee” shall not include any public shareholders of the Trust Company, any Financing Parties or their Affiliates.

“Inspection” is defined in Section 3.7.1.

“Insurance” means the insurance required under Section 11 of this Sublease.

“Interest Rate” is defined in Appendix B.

“International Interest” has the meaning given to such term in the Cape Town Convention.

“International Registry” means the registry established and maintained pursuant to the Cape Town Convention.

“KYC” is defined in Section 15.1.9.

“Landing Gear” means the landing gear assembly of the Aircraft, excluding any rotatable components.

“Law” means and includes (a) any statute, decree, constitution, regulation, order, judgment or other directive of any Governmental Entity; (b) any treaty, pact, compact or other agreement to which any Governmental Entity is a signatory or party; (c) any judicial or administrative interpretation or application of any Law described in (a) or (b) above; and (d) any amendment or revision of any Law described in (a), (b) or (c) above.

“Lien” means any mortgage, chattel mortgage, security interest, charge, pledge, lien, conditional sale agreement, title retention agreement, equipment trust agreement, encumbrance, International Interest, assignment, hypothecation, right of detention or any other agreement or arrangement having the effect of conferring security.

“LLP” means life limited part.

“Loss Payees” is defined in Section 11.2.2.

“Losses” means any and all cost, expense (including any and all reasonable legal fees and expenses and the reasonable fees and expenses of other professional advisers), claims, proceedings, losses, liabilities, obligations, damages (whether direct, indirect, special, incidental or consequential), suits, judgments, fees, penalties or fines (whether criminal or civil) of any kind or nature whatsoever, including any of the foregoing arising or imposed with or without any Indemnitee’s fault or negligence, whether passive or active or under the doctrine of strict liability.

“Maintenance Program” means an Aviation Authority approved maintenance program of Sublessee for the Aircraft in accordance with the Manufacturer’s specifications, requirements, service bulletins, planning documents, maintenance manuals and documents and encompassing scheduled maintenance (including block maintenance), condition-monitored maintenance, and/or on-condition maintenance of Airframe, Engines and Parts, including servicing, testing, preventive maintenance, repairs, structural inspections, system checks, overhauls, approved modifications, service bulletins, engineering orders, airworthiness directives, corrosion control, inspections and treatments.

“Major Check” means any C Check, multiple C Check or heavier check (including structural inspections and a corrosion prevention and control program) recommended for commercial aircraft of the same model as the Aircraft by its manufacturer (however denominated) as set out in the Maintenance Program.

“Manufacturer” means: (a) as to the Airframe, The Boeing Company; (b) as to the Engines, CFM International, Inc. and (c) as to Parts, any type certificate holder of a Part installed on the Aircraft.

“Manufacturer’s Maintenance Planning Document” or “MPD” means the recommended maintenance program from the Aircraft issued by the Manufacturer as in effect at the time of any applicable determination.

“Minimum Airframe Life-Limited Component Cycles” means the figure corresponding to such term set forth in Appendix G.

“Minimum Airframe Life-Limited Component Flight Hours” means the figure corresponding to such term set forth in Appendix G.

“Minimum APU Limit” means the figure corresponding to such term set forth in Appendix G.

“Minimum Component Calendar Life” means the figure corresponding to such term set forth in Appendix G.

“Minimum Component Cycles” means the figure corresponding to such term set forth in Appendix G.

“Minimum Component Flight Hours” means the figure corresponding to such term set forth in Appendix G.

“Minimum Engine Cycles” means the figure corresponding to such term set forth in Appendix G.

“Minimum Engine Flight Hours” means the figure corresponding to such term set forth in Appendix G.

“Minimum Landing Gear Calendar Time” means the figure corresponding to such term set forth in Appendix G.

“Minimum Landing Gear Cycles” means the figure corresponding to such term set forth in Appendix G.

“Minimum Landing Gear Flight Hours” means the figure corresponding to such term set forth in Appendix G.

“Minimum Engine LLP Cycles” means the figure corresponding to such term set forth in Appendix G.

“Minimum Liability Coverage” means the amount specified as such in Appendix B, designating the minimum combined single limit under the airline liability insurance required pursuant to this Agreement.

“Operative Documents” means, collectively, this Sublease, the ATSA, the Technical Acceptance Certificate, the Sublease Supplement, the documents referred to in the definition of “Operative Documents” set forth in the Head Lease and any other document notified by Sublessor to Sublessee as being an “Operative Document”.

“Other Sublease Agreements” means, collectively, each aircraft sublease agreement, aircraft lease agreement or other lease agreement (however titled) between Sublessor (or an Affiliate of Sublessor), as lessor (however described), and Sublessee (or an Affiliate of Sublessee), as lessee (however described), in effect from time to time.

“Owner Participant” has the meaning given to such term in the Head Lease.

“Parts” means any item, including materials, accessories, components, equipment, appliances, instruments, avionics, appurtenances, furnishings, and any other equipment or components of whatever nature (other than the Engines), which are installed in or attached or appurtenant to the Aircraft or either of the Engines.

“Party” means Sublessor and Sublessee.

“Person” means any individual person, any form of corporate or business association, trust, Governmental Entity, or organization or association of which any of the above is a member or a participant.

“Permitted Lien” is defined in Section 9.1.

“QEC” means all of the “quick engine change” components associated with each Engine.



“Redelivery Check” is defined in Appendix H.

“Regulations” means any Law or regulation (including any internal corporate regulation), official directive or recommendation, mandatory requirement or contractual undertaking, or airworthiness requirements or limitations which applies to Sublessee or the Aircraft and any Law or regulation, official directive or recommendation or mandatory requirement which applies to Sublessor, Head Lessor, Owner Participant, Financing Parties or [\*\*\*] (including any applicable Laws or sanctions issued by Ireland, the United States, the European Union or the United Nations).

“Replacement Engine” means an engine of the same manufacturer and model, or at Sublessee’s option an engine of an improved model and having equivalent or better value, utility, modification status, time elapsed since hot section refurbishment, cold section refurbishment, reduction gear overhaul, life limited part utility and remaining equivalent warranty status as the Engine it replaces under Section 6.2.1 and is otherwise of an equivalent value and utility and suitable for installation and use on the Airframe without impairing the value or utility of the Airframe and compatible with the remaining installed Engine(s).

“Required EGT Margin” means the figure corresponding to such term set forth in Appendix G.

“Return” means the return and redelivery of the Aircraft to Sublessor by Sublessee upon the Expiration.

“Return Condition Requirements” is defined in Section 17.2.

“Return Date” means the date at Expiration when the Aircraft is returned to Sublessor in conformity with the Return Condition Requirements, as evidenced by the execution of the Return Receipt by Sublessee and Sublessor.

“Return Location” means a location in the continental United States or such other location as may be mutually agreed by the Parties in writing.

“Return Receipt” means a return receipt in the form of Appendix F.

“Sales Taxes” is defined in Section 8.2.1(a).

“Special FAA Counsel” means Crowe & Dunlevy P.C., Oklahoma City, Oklahoma.

“Sublease” means this Agreement, as amended, supplemented or otherwise modified from time to time.

“Sublease Supplement” means the Sublease Supplement No. 1, substantially in the form of Appendix E, which, as of the Delivery Date, will be executed by Sublessor and Sublessee and, together with this Agreement, filed with the FAA for recordation (assuming that the Aircraft is registered in the United States) with the economic terms in Appendix B deleted in the document filed for such purposes to the extent not prohibited by Law.

“Sublessor Taxes” is defined in Section 8.3

“Sublessor’s Liens” means Liens on or relating to or affecting the Aircraft, the Airframe, the Aircraft Documents, Engines, APU or any Parts arising as a result of: (a) claims against Sublessor not created by this Agreement or the ATSA; (b) acts of Sublessor neither permitted nor required to be taken by Sublessor under this Agreement; (c) the transfer by Sublessor of its interest or any part of an interest in the Aircraft; (d) Taxes imposed against Sublessor which Sublessee has not agreed to indemnify against pursuant to this Sublease or the ATSA; or (e) any act, omission, or circumstance occurring or omitted prior to the Delivery Date or after the Return Date (for clarity, “Sublessor” solely as used in this definition will include (1) Affiliates of Sublessor and (2) Head Lessor, Owner Participant and Affiliates of Owner Participant).

“Tax Indemnitees” means Owner Participant, Head Lessor, Sublessor, [\*\*\*], Head Lessor Parent, each Financing Party, their respective subsidiaries and each Person with whom any of the foregoing files a consolidated tax return.

“Taxes” means any and all taxes (including withholding taxes, value added taxes, deductions, transaction privilege taxes, sales taxes or assessments of any kind or form), charges, fees, imposts, levies, or other charges of any nature, together with any penalties, fines, or interest thereon or other additions thereto which are imposed, withheld, levied, or assessed by or on behalf of, or otherwise payable to, any Governmental Entity.

“Technical Acceptance Certificate” is defined in Section 3.8.

“Term” is defined in Section 3.2.

“Termination” means the termination of the lease of the Aircraft under this Agreement, which termination arises prior to the Expiration Date pursuant to Section 2.1, 2.2, 16.1.1(j), or 19.1, or otherwise under this Agreement.

“Termination Date” means the date on which a Termination is effective.

“Termination Notice” is defined in Section 20.12(a).

“Total Loss” means any of the following events with respect to the Airframe, an Engine, or the Aircraft Documents: (a) the destruction, damage beyond economical repair, or such property becoming permanently unfit for normal use, for any reason whatsoever; (b) any event which results in an insurance settlement on the basis of actual or constructive or compromised or agreed or arranged total loss; (c) the disappearance of the Aircraft, if the Aircraft is unreported for a period of [\*\*\*] days after commencement of a flight; (d) loss of possession or loss of use by Sublessee for a period of more than [\*\*\*] days due to hijacking, theft, or other criminal actions; (e) the condemnation, confiscation, appropriation, expropriation or seizure of, or requisition of title to or use of, the Aircraft or an Engine by any Governmental Entity, other than a requisition for use by any Governmental Entity of the United States or any political subdivision thereof, for the lesser of (i) a period of more than [\*\*\*] days (or [\*\*\*] days in the case of requisition for use or hire by the government of the State of Registry) and (ii) a period equal to or exceeding the remainder of the Term; or (f) the operation or location of the Aircraft, while under requisition for use by any Governmental Entity, in any areas excluded from coverage by any insurance policy in effect with respect to such Aircraft required by the terms of this Agreement, unless Sublessor and Sublessee will have obtained an indemnity in freely transferable Dollars from that Governmental Entity covering the risks excluded from coverage and satisfactory to both Sublessor and Sublessee.

“Trust Company” means Bank of Utah.

“UCC” means the Uniform Commercial Code as in effect in the State of New York.

“Written Summaries” is defined in Section 7.5.1.

## 2. **Conditions Precedent.**

2.1 Sublessor’s Conditions Precedent. Sublessor’s obligation to deliver and to lease the Aircraft to Sublessee will be subject to satisfaction of each of the following conditions precedent (or waiver by Sublessor):

(a) All of the representations and warranties of Sublessee set forth in Section 14.1 will be true and correct in all material respects as of the Effective Date and as of the Delivery Date.

(b) Sublessor will have received, on or before the Delivery Date, all of the following, all of which will be in form and substance satisfactory to Sublessor:

(i) a certificate of insurance issued by the insurer or broker for Sublessee (or Sublessee’s sublessee/operator) evidencing compliance with the insurance provisions of Section 11;

(ii) the Technical Acceptance Certificate in the form of Appendix D, as executed by Sublessee; and

(iii) the Sublease Supplement executed by Sublessee.

(c) The delivery date under the Head Lease will have occurred;

(d) Sublessee will have made payment of the first installment of Basic Rent in accordance with Section 4.3.1.

(e) An Event of Default (as defined by the relevant Other Sublease Agreement) will not have occurred and be continuing under any of the Other Sublease Agreements.

(f) Sublessee will have: (a) delivered to Special FAA Counsel its acceptable original or digital signature for this Agreement and the Sublease Supplement; and (b) irrevocably authorized and instructed Special FAA Counsel to file original counterparts of this Agreement and the Sublease Supplement with the FAA (excluding the financial terms which will bear the legend “intentionally left blank for FAA filing purposes”) for recordation upon satisfaction or waiver of the conditions precedent set forth in Section 2.2.

(g) Sublessee will have: (a) taken all required steps to appoint Special FAA Counsel as its Professional User Entity (as defined in the Cape Town Convention) for purposes of registering its international interest under this Agreement with the International Registry; and (b) irrevocably authorized and instructed Special FAA Counsel to register such international interest with the International Registry upon satisfaction or waiver of the conditions precedent set forth in Section 2.2.

## 2.2 Sublessee's Conditions Precedent.

2.2.1 Sublessee's obligation to lease the Aircraft from Sublessor will be subject to satisfaction of each of the following conditions precedent (or waiver by Sublessee):

(a) Sublessee will have executed and delivered the Technical Acceptance Certificate to Sublessor pursuant to Section 3.8.

(b) No loss or destruction to the Aircraft will have occurred since Sublessee delivered the executed Technical Acceptance Certificate to Sublessor pursuant to Section 3.8.

(c) The Aircraft will be validly registered with the Aviation Authority in the name of Head Lessor (or such other party as required by the Aviation Authority).

(d) Sublessor will have executed and delivered the Sublease Supplement.

(e) Sublessor will have: (i) delivered to Special FAA Counsel its acceptable original or digital signature for this Agreement and the Sublease Supplement; and (ii) irrevocably authorized and instructed Special FAA Counsel to file original counterparts of this Agreement and the Sublease Supplement with the FAA (excluding the financial terms which will be "intentionally left blank for FAA filing purposes") for recordation upon satisfaction of the conditions precedent set forth in Section 2.1.

(f) Sublessor will have: (i) obtained an authorization code from the FAA for the international interest created by this Agreement with respect to the Airframe and Engines by filing with the FAA an AC Form 8050-135; (ii) taken all required steps to appoint Special FAA Counsel as its Professional User Entity for purposes of registering such international interest with the International Registry; and (iii) irrevocably authorized and instructed Special FAA Counsel to register such interest with the International Registry upon satisfaction of the conditions precedent set forth in Section 2.1.

### 3. Sublease of Aircraft; Inspection; Technical Acceptance; Delivery.

3.1 Sublease of the Aircraft. As of the Delivery Date, Sublessor will lease the Aircraft to Sublessee, and Sublessee will lease the Aircraft from Sublessor, for the Term, and Sublessee will return the Aircraft to Sublessor, and Sublessor will accept the Aircraft from Sublessee, on the Expiration Date (or an earlier Termination Date, if applicable), upon and subject to the terms and conditions of this Agreement.

3.2 Term. The term of this Agreement will be the period commencing on the Delivery Date and ending on the Expiration Date or on any earlier Termination Date, as applicable, and, unless otherwise stated, includes any Extended Term (the "Term").

3.3 Anticipated Delivery Month. Sublessor and Sublessee: (a) anticipate that the Aircraft will be available for delivery to Sublessee during the Anticipated Delivery Month; and (b) will act in good faith at all times in an attempt to effect Delivery during or about the Anticipated Delivery Month.

3.4 A Lease Only, Section 1110. It is the intention of the Sublessor and Sublessee that the Sublease, to the fullest extent available under applicable Law, entitles Sublessor to the benefits of Section 1110 of Title 11 of the United States Code with respect to the Aircraft including in case of a filing by Sublessee under such Title 11. At all times during the Term, full legal title to the Aircraft will remain vested in Head Lessor to the exclusion of Sublessor and Sublessee, notwithstanding the Delivery to, and the use of the Aircraft by, Sublessee. In furtherance of the foregoing, Sublessor and Sublessee confirm their joint intent that this Agreement will constitute a lease for tax purposes.

3.5 Delivery. On the Delivery Date, if all the conditions set forth in Sections 2.1 and 2.2 have been satisfied or waived, the Aircraft will be tendered for delivery to, and accepted by, Sublessee pursuant to the procedure set forth herein by executing and delivering the Sublease Supplement (the "Delivery"). The Delivery Date will be the date reflected on the Sublease Supplement. The Aircraft will be tendered to Sublessee for delivery at the Delivery Location.

#### 3.6 Condition of the Aircraft; Modifications.

3.6.1 Sublessor, as a condition of Sublessee's obligation to accept the Aircraft, will, at its sole cost and expense, cause the Aircraft to meet all requirements set forth in Appendix G (the "Delivery Condition Requirements") at Delivery.

3.6.2 All unserviceable components and all discrepancies identified by Sublessee during the Inspection will be corrected by Sublessor at Sublessor's expense prior to Delivery (except for such discrepancies that are listed on the Technical Acceptance Certificate that will be corrected by Sublessor within such period after Delivery as Sublessee consents to, at its sole discretion, in writing, provided that, in Sublessor's reasonable opinion, it is not impracticable or prohibitively expensive to correct such discrepancy).

#### 3.7 Inspection.

3.7.1 Subject to the Head Lease, Sublessee shall inspect the Aircraft under this Sublease (including such rights as Sublessor has under the Head Lease to be present and inspect, on an ongoing basis, the conversion of the Aircraft and including a demonstration flight under normal operating conditions, which shall be undertaken for the benefit of Sublessee at no expense to Sublessee) (the "Inspection") to determine whether the Aircraft fulfills the Delivery Condition Requirements

3.7.2 If Sublessee's inspection of the Aircraft shows that the Aircraft does not fulfill the Delivery Condition Requirements, Sublessor will correct (or cause Head Lessor to correct) any Discrepancy and make the Aircraft available for re-inspection by Sublessee provided that, in Sublessor's or Head Lessor's reasonable opinion, it is not impracticable or prohibitively expensive to correct the Discrepancy.

3.7.3 If Sublessor notifies Sublessee that neither it nor Head Lessor intends to correct the Discrepancy, either party may terminate the Sublease. In the event of such a termination, all obligations of each party under the Sublease will end on the date of such notice. Sublessee will remain obligated under its indemnity set forth in Section 3 of Appendix G.

3.8 Technical Acceptance. Upon the completion of the Inspection and, subject to Section 3.6.2, the performance by Sublessor of all corrections required to bring the Aircraft into conformity with the Delivery Condition Requirements (except to the extent that such corrections are deferred by Sublessee as described in Section 3.6.2), Sublessee will execute and deliver to Sublessor a Technical Acceptance Certificate substantially in the form of Appendix D (the "Technical Acceptance Certificate"). Once Sublessor has received the Technical Acceptance Certificate from Sublessee, Sublessor will promptly cause Delivery to occur. The Parties will mutually agree on arrangements for ferrying the Aircraft from the Delivery Location to the United States at Sublessor's cost (including, for clarity, the cost of importing the Aircraft), including the possible use of a third party service provider, and Sublessee will be responsible to coordinate such arrangements.

3.9 Modifications. Except as required to be performed by Sublessor to satisfy the Delivery Condition Requirements, all work required to be performed on the Aircraft solely to satisfy Sublessee's operational requirements will be performed by an Authorized Maintenance Provider at Sublessee's cost and expense. Without limiting the generality of the foregoing, should Sublessee (at any time during the Term) elect to make a change from the Maintenance Program, Sublessee will be responsible for creating the bridge package for such special program.

#### **4. Payments; Method of Payment.**

4.1 [Reserved].

4.2 Basic Rent.

4.2.1 Sublessee will pay, in advance, Basic Rent to Sublessor on each Basic Rent Date until the earlier of the following:

- (a) in the event of a Total Loss, the payment to Sublessor or its designee of the Agreed Value or receipt of confirmation of payment from the Aircraft's insurer in accordance with Section 19.1; or
- (b) the Return Date; and

4.2.2 The termination of Sublessee's obligation to pay Basic Rent pursuant to Section 4.2.1 above will not be in derogation of Sublessor's other rights and remedies against Sublessee in the event of a Return of the Aircraft that does not conform to the Return Condition Requirements.

#### 4.3 Basic Rent Payments.

4.3.1 The first payment of Basic Rent will be made on or prior to the Delivery Date, as a condition of the Delivery, in an amount equal to the product of: (a) the Basic Rent multiplied by (b) a fraction (i) whose numerator is the number of days from and after the Delivery Date remaining in the month which includes the Delivery Date and (ii) whose denominator is the total number of days in such month.

4.3.2 On each Basic Rent Date following the Delivery Date (through the time set forth in Section 4.2.1) Sublessee will pay the Basic Rent to Sublessor as required by Section 4.2.1.

4.3.3 All payments owing by Sublessee to Sublessor under this Agreement (including the payment of Basic Rent) will be made in Dollars by the wire transfer of immediately available funds to the bank account designated in Appendix B or to such other bank account as Sublessor may designate in writing to Sublessee.

4.4 Due Date Not on Business Day. In the event any payment required under this Agreement is due on a day that is not a Business Day, then such payment will be made on or before the next succeeding Business Day.

4.5 No Abatement. Sublessee's obligations to pay Basic Rent will be absolute and unconditional and will not be affected by any circumstances occurring from and after the Delivery Date, including any set-off, counterclaim, recoupment, defense or other right Sublessee may have against Sublessor. Provided the ATSA is in effect with respect to the Aircraft, the provisions of the ATSA will control with respect to Sublessee's responsibility (including through one of Sublessee's Affiliates), if any, under the ATSA should the Aircraft (or any component thereof) become unavailable for use. There will be no abatement of Basic Rent for any period when the Aircraft will be rendered unfit for use, grounded, unserviceable for any reason whatsoever, hijacked, confiscated, seized, requisitioned, restrained, or appropriated.

4.6 Interest on Overdue Amounts. Any amount that is more than [\*\*\*] days overdue pursuant to this Agreement will bear interest at the Interest Rate indicated on Appendix B, calculated from the [\*\*\*] day following the due date of such payment. The payment of such interest will be made together with the payment of the overdue amount.

#### 5. **Registration; Nameplates; Filings.**

5.1 Registration. At all times during the Term, the Aircraft will be registered with the applicable Aviation Authority in the name of Head Lessor (or Sublessee if operating in a jurisdiction that requires registration in the name of the operator of the Aircraft).

5.2 Nameplates. Sublessee will maintain nameplates containing the nameplate inscription as follows, which Sublessor shall arrange to be affixed to the Aircraft on or prior to Delivery:

“This Aircraft/Engine is owned by Bank of Utah, not in its individual capacity, but solely as Owner Trustee, is leased to Amazon.com Services LLC and is subleased to Sun Country, No encumbrances or liens may be created over it nor may it be in the possession of or be operated by, any other person without the prior written consent of Bank of Utah, not in its individual capacity, but solely as Owner Trustee, and Amazon.com Services LLC”;

5.3 Filings. At or before Delivery, this Agreement (absent the provisions of Appendix B) and such other documents as Sublessor may direct, will be filed with the Aviation Authority and with any other Governmental Entity registrar or international registrar as provided by this Agreement, including the International Registry. All costs and expenses (including the legal fees charged by Special FAA Counsel but not including the legal fees charged by Sublessor’s counsel) relating to each of such filings will be paid as set forth in Section 20.3.

#### **6. Possession, Use and Operation of the Aircraft; Risk of Loss or Damage.**

6.1 Possession of Aircraft; Operations. During the Term, Sublessee will be entitled to the possession and use of the Aircraft. Sublessee will not, without the prior written consent of Sublessor, sublease or otherwise transfer possession of the Aircraft, any Engine or any Part to any person or entity except as provided in this Section 6.1. So long as an Event of Default will not have occurred and be continuing, Sublessee may, without the prior written consent of Sublessor, exercise the following rights:

6.1.1 Sublessee may deliver, or cause to be delivered, possession of the Aircraft, any Engine or any Part to the Manufacturer or to any Authorized Maintenance Provider for testing, service, repair, maintenance, or overhaul work on the Aircraft, any Engine or on any Part or for alterations or modifications in or additions thereto to the extent required or permitted by the terms of this Agreement;

6.1.2 Sublessee may transfer possession of the Aircraft to the United States of America or any instrumentality or agency thereof as part of the Civil Reserve Air Fleet program (“CRAF Program”). Sublessee will promptly notify Sublessor in writing in the event of the use of the Aircraft under a CRAF Program activation by the U.S. Government. All of Sublessee’s obligations under the Sublease will continue to the same extent as if such activation had not occurred, including, the prohibition on subleasing. Any provisions of the Sublease to the contrary notwithstanding, if there is use of the Aircraft pursuant to the CRAF Program and/or CRAF Program activation, Sublessor agrees that the insurance the Sublessee is required to maintain pursuant to terms thereof may be supplemented or replaced by insurances provided under Title XIII of the Federal Aviation Act of 1958, and/or U.S. Government indemnification (which Title XIII insurances and indemnification will be, as to the Aircraft, in an amount not less than the Agreed Value amount for the



Aircraft and, as to all other insurances, in amounts not less than those required by the terms of the Sublease); provided, however, that Sublessee will remain responsible for full compliance with all the provisions of the Sublease, to the extent Title XIII and/or the U.S. Government indemnification do not satisfy Sublessee's obligations under the Sublease, including as to scope of coverage or additional insureds covered.

(a) If there is use of the Aircraft pursuant to the CRAF Program and/or CRAF Program activation, there will be no limitation on the geographic area in which the Aircraft may be operated so long as, taken as a whole, Sublessee's insurance, the Title XII insurance and/or the indemnification provided by the U.S. Government shall fully cover (without any geographic exclusions) the insurance requirements set forth herein.

(b) If an Event of Default occurs and Sublessor elects to pursue its remedies in accordance with the provisions of the Sublease, Sublessor will so notify the U.S. Government by sending a written communication with a copy to Sublessee as follows:

Headquarters Air Mobility Command

AMC Contracting Office – XOKA

Scott Air Force Base, Illinois 62225-5007

Sublessee hereby authorizes Sublessor to contact and deal directly with CRAF Program representatives, including the Air Mobility Command, during the occurrence and continuance of an Event of Default, in connection with the exercise of any and all remedies provided under the Sublease, including to arrange for repossession of the Aircraft directly from the Air Mobility Command, payments under the CRAF Program to be made directly to Sublessor and the termination of the Aircraft's participation in the CRAF Program.

(c) So long as no Event of Default has occurred and is continuing all payments received by Sublessor or Sublessee from any Governmental Entity in connection with the use of the Aircraft under the CRAF Program will be paid over to or retained by Sublessee. If an Event of Default has occurred and is continuing, Sublessor may direct the Governmental Entity to make all payments to Sublessor (or its designee) and all payments received by Sublessor (or its designee) or Sublessee from such Governmental Entity in connection with the use of the Aircraft under the CRAF Program may be used by Sublessor and applied to the payment obligations as and when due and payable under the Sublease in such order and in such amount as Sublessor may elect in its sole discretion.

6.1.3 Sublessee may transfer possession of any Engine or any Part to any person or entity as permitted in Section 6.2.

## 6.2 Possession of Engines and Parts.

6.2.1 Replacement: Sublessee must replace, within [\*\*\*]days thereof, or if Sublessee is unable to find a suitable engine that would satisfy the requirements of a Replacement Engine within such time period, and Sublessee has provided evidence reasonably satisfactory to Sublessor that Sublessee is diligently trying to find such an engine, within an additional [\*\*\*] days, any Engine that has suffered an Engine Total Loss, in accordance with Section 6.2.2, and any Part that is permanently removed from the Aircraft must be replaced in accordance with Section 6.2.2. Any Engine or Part may be installed on another aircraft Sublessee owns or leases in accordance with Section 6.2.3. Sublessee may temporarily install an engine or part in accordance with Section 6.2.4. Sublessee shall obtain from any person to whom possession of an Engine is given, and from the lessor of any airframe on which an Engine is installed and from any holder of a Lien in any airframe on which an Engine is installed, an agreement in writing (which agreement, in the case of a lease or Lien, may be contained in the applicable lease or Lien agreement covering such airframe) that such Person will respect the interests of Head Lessor as owner and Sublessor as lessor, respectively, and of the Financing Parties, in such Engine and will not acquire or claim any rights, title or interest in such Engine as a result of such Engine being installed on such other airframe at any time while such Engine is subject to the Sublease. In the event Sublessee shall have received from a lessor of or a secured party holding a Lien in any airframe leased to Sublessee or owned by Sublessee a written agreement pursuant to the foregoing sentence and the lease or Lien covering such airframe also covers an engine or engines owned by the lessor under such lease or subject to such Lien in favor of the secured party under such Lien, Sublessor hereby agrees for the benefit of such lessor or secured party that Sublessor will respect the interest of such lessor or secured party and will not acquire or claim as against such lessor or secured party, any rights, title or interest in any such engine as a result of such engine being installed on the Airframe at any time while such engine is subject to such lease or Lien and owned by such lessor or subject to a Lien in favor of such secured party. Sublessor further agrees that in respect of the interest of and for the benefit of a spare engine owner, lessor or secured party pursuant to a Lien whose engine has been installed on the Airframe in accordance with Section 6.2.4 hereof, it will not acquire or claim as against such owner, lessor or secured party any rights, title or interest in any such spare engine as a result of such spare engine being installed on the Airframe. Sublessee will ensure that any Engine or Part not installed on the Aircraft (or an aircraft permitted by Section 6.2.3) is properly and safely stored and insured and kept free of Liens.

6.2.2 Permanent Replacement: Sublessee may, with prior written notice to Sublessor of at least [\*\*\*]days, and subject to the satisfaction of the terms and conditions of this Section permanently replace an Engine that has not suffered a Total Loss or a Part. Where Sublessee permanently replaces an Engine or a Part:

- (a) in the case of an Engine, it must be a Replacement Engine;

(b) in the case of a Part, the replacement part must be an Manufacturer approved Part (except as set forth in Section 6.3), be in good operating condition, must not have been involved in any accident or incident, must not have been installed on an aircraft registered on a military aircraft register, must have as much useful life available until the next expected maintenance procedure, must be of the same or a more advanced Manufacturer configuration status, make and model as the Part it is replacing and it must otherwise be of an equivalent value and utility as the Part it is replacing;

(c) the Replacement Engine or replacement part must have become and remain, until replaced in accordance with this Section 6.2, the property of Head Lessor free from Liens (other than Permitted Liens), and subjected to the lien of any applicable Financing Documents and the rights of any Financing Parties;

(d) Sublessee must have full details of the source and maintenance records of the Replacement Engine or replacement part. In the case of replacement serialized parts, documentation shall be back to birth and in the case of serialized rotatable parts, shall include a complete service history; and

(e) Sublessee shall comply with the requirements of Section 6.2.6, and at Sublessor's expense, any requirements under the Financing Documents in connection with any such replacement including to provide such legal opinions and other documents as may be required under such Financing Documents.

6.2.3 Other Aircraft. An Engine or Part may be installed on an aircraft which Sublessee owns or leases, which is insured to Sublessor's satisfaction, if:

(a) no Event of Default has occurred and is continuing;

(b) Sublessee has operational control over the aircraft;

(c) Head Lessor keeps the ownership of the Engine or Part concerned (and any interest of any Financing Parties in such Engine or Part remains unaffected) until replaced in accordance with Section 6.2.2;

(d) the Engine or Part does not become subject to a Lien (except a Permitted Lien) and the applicable airframe is not subject to any Lien except a Permitted Lien or a lease or Lien described in Section 6.2.1 above, and in case of an Engine, the Sublessor has received the recognition of rights agreement provided for in Section 6.2.1; and

(e) the Engine or Part is replaced in accordance with Section 6.2.2 and is removed from the aircraft as soon as practicable under Sublessee's engine rotation program but not later than the Expiration Date;

6.2.4 Temporary Replacement: Sublessee may install any engine or part on the Aircraft as a temporary replacement if:

(a) no Event of Default has occurred and is continuing;

(b) in the case of a temporary engine, such engine is of the same manufacturer and is otherwise suitable for installation and use on the Airframe without impairing the utility of the Airframe and is compatible with the remaining installed Engine(s);

(c) in the case of a temporary part, such part must be Manufacturer approved (except as set forth in Section 6.3), be in good operating condition, be of the same (or better) utility, must not have been involved in an incident or accident, must not have been installed on an aircraft registered on a military aircraft register and be of the same or a more advanced Manufacturer configuration status, make and model as the Part that it is replacing on a temporary basis;

(d) either (x) there is not available an engine or part complying with the requirements of the Sublease for a Replacement Engine or Part; or (y) it would result in an unreasonable disruption of the operation of the Aircraft or the business of Sublessee to have the Aircraft grounded until such time as an engine or part complying with the requirements of the Sublease for a Replacement Engine or Part becomes available for installation;

(e) as soon as practicable (under Sublessee's engine rotation program in the case of an engine) after an engine or part is installed on the Aircraft, but before the earlier of [\*\*\*] days after such temporary replacement or the Expiration Date, Sublessee removes that engine or part and replaces it with the original Engine or Part (or by an engine or part which is allowed by Section 6.2.2); and

(f) the Insurance for the Aircraft is not adversely affected.

6.2.5 Pooling/Interchange: Sublessee shall not subject any Engine to any pooling, interchange, lease or similar arrangement unless Sublessee obtains Sublessor's prior written consent thereto, which consent shall not be unreasonably withheld.

6.2.6 Title to Removed Engines or Parts. Any Engine or Part at any time removed from the Aircraft will remain the property of Head Lessor (and subject to the interest of any Financing Party) unless and until a replacement has been effected in accordance with Section 6.2.1, and title to that Replacement Engine or Part has been transferred to Head Lessor subject to the Head Lease and Sublease (and any Financing Documents), free from all Liens (other than a Permitted Lien and the lien of any Financing Party), whereupon title to the replaced Engine or Part will, provided no Event of Default has occurred and is continuing, be transferred to Sublessee, in accordance with Section 6.2.1.

6.3 Pooling of Parts. Any Part removed from the Aircraft as provided in Section 7 may be subjected by Sublessee to normal interchange or pooling agreements or arrangements customary in the airline industry and entered into by Sublessee with other licensed air carriers or aviation parts suppliers in the ordinary course of its business, except that the part permanently replacing such removed Part will be incorporated or installed in or attached to the Aircraft in accordance with Section 7 promptly upon the removal of such removed Part. In addition, any replacement part, when incorporated or installed in or attached to the Aircraft in accordance with

Section 7, may be owned by another such air carrier or aviation parts supplier subject to such pooling arrangement, except that the Part so removed remains the property of Head Lessor and subject to this Agreement and that Sublessee, at its expense, promptly thereafter either (a) causes title to such replacement part to vest in Head Lessor free and clear of Liens other than Permitted Liens, in accordance with Section 7; or (b) replaces such replacement part by incorporating, installing, or attaching to the Aircraft a further replacement part owned by Sublessee free and clear of all Liens other than Permitted Liens, and causes title to such further replacement part to vest in Head Lessor and causes such replacement part to become subject to this Agreement.

6.4 [Reserved]

6.5 Commercial Operations. Sublessee will not use or permit the Aircraft to be operated except: (a) in commercial operation for which Sublessee is duly authorized by the Laws of the Governmental Entity having jurisdiction(s) to whose Laws the operation of the Aircraft is subject; and (b) flights that are ancillary to the commercial flights referenced in Section 6.5, including ferry and maintenance flights and such flights required for the aircrew to maintain their currency.

6.6 Lawful and Safe Operations. Sublessee will operate the Aircraft for commercial purposes from the Delivery Date until the Return from a base within the Habitual Base, provided always that Sublessee must not use or operate the Aircraft or suffer or permit the Aircraft to be used or operated:

6.6.1 in violation of any applicable Regulations or in a manner causing Sublessor, Head Lessor, Owner Participant, any Financing Party or [\*\*\*] to be in violation of any applicable Regulations; provided that an Event of Default shall not be deemed to occur under this sentence for any isolated extraordinary emergency event beyond Sublessee's control that Sublessee is diligently trying to rectify, which does not involve any risk of criminal liability or any material risk of sale, forfeiture or loss of the Aircraft, and Sublessee causes the Aircraft to be removed from the sphere of influence of such event and for Sublessee to be in compliance with this Section as soon as practicable;

6.6.2 for any purpose for which the Aircraft was not designed or which is illegal;

6.6.3 to carry potentially dangerous cargo on the Aircraft unless handled and carried per ICAO's Technical Instructions for the Safe Transportation of Dangerous Good by Air to the extent applicable to an operator located in the same jurisdiction as Sublessee;

6.6.4 in any circumstances or place where the Aircraft is not covered by insurance required by Section 11; provided that the failure of Sublessee to comply with this sentence shall not constitute an Event of Default unless such failure shall continue for in excess of [\*\*\*] days where such failure is attributable to a hijacking, medical or weather emergency, equipment malfunction navigational error or other isolated extraordinary event beyond Sublessee's control so long as Sublessee is diligently proceeding to rectify such failure as soon as practicable during such [\*\*\*] day period; or

6.6.5 for purposes of training, qualifying or re-confirming the status of cockpit personnel except for the benefit of Sublessee's cockpit personnel, and then only if the use of the Aircraft for such purpose is not disproportionate to the use for such purpose of other aircraft of the same type operated by Sublessee.

AS BETWEEN SUBLESSEE AND THE INDEMNITEES, SUBLESSEE ACKNOWLEDGES AND AGREES THAT SUBLESSEE IS SOLELY RESPONSIBLE FOR THE DETERMINATION AND IMPLEMENTATION OF ALL SECURITY MEASURES AND SYSTEMS NECESSARY OR APPROPRIATE FOR THE PROPER PROTECTION OF THE AIRCRAFT AND SUBLESSOR AND THE INDEMNITEES SHALL HAVE ABSOLUTELY NO RESPONSIBILITY THEREFOR.

6.7 Maintenance. Sublessee will maintain, overhaul and repair the Aircraft, so that:

6.7.1 the Aircraft is kept in as good operating condition and repair as the condition of the Aircraft at Delivery and after giving effect to any post-Delivery modifications, repairs or maintenance paid for or otherwise provided by or on behalf of Sublessor;

6.7.2 Sublessee has a current certificate of airworthiness (issued by the Aviation Authority in the appropriate public transport category) for the Aircraft;

6.7.3 the Aircraft complies with all applicable Laws and Regulations and the standards stipulated by FAR Part 121 and in a manner to maintain all warranty and service life policies and the requirements of all ADs and all service bulletins designated as "mandatory," which are required to be carried out before the Return Date or within the AD Compliance Period;

6.7.4 all maintenance is carried out according to the Maintenance Program and shall be performed, and the Aircraft shall be maintained, overhauled and repaired, in at least the same manner and with at least the same care, including maintenance scheduling, modification status and technical condition, as is the case with respect to similar aircraft owned or otherwise operated by Sublessee. No change shall be made to the Maintenance Program without first giving reasonable written notice to Sublessor of such change; and

6.7.5 all repairs and Parts associated with such repairs must meet the applicable Manufacturer standard and specifications (approved or recommended by the Manufacturer, as the case may be); provided, however, that non-Manufacturer parts may be used in the repair of airframe furnishings, including cargo loading systems. Whether non-Manufacturer parts will be acceptable in connection with an Equipment Change will be determined pursuant to Section 6.6.2.

6.8 Net Lease. The Sublease is a net lease. Sublessee's obligation to pay Basic Rent and to perform all of its other obligations under the Sublease is absolute and unconditional no matter what happens and no matter how fundamental or unforeseen the event, including any of the following:

- (a) any right of set-off, counterclaim, recoupment, defense or other right which either party to the Sublease may have against the other (including any right of reimbursement) or which Sublessee may have against any Manufacturer, any manufacturer or seller of or any Person providing services with respect to the Aircraft, any Engine or any Part or any other Person, for any reason whatsoever;

(b) any unavailability of the Aircraft following the Delivery Date for any reason, including a requisition of the Aircraft or any prohibition or interruption of or interference with or other restriction against Sublessee's use, operation or possession of the Aircraft (whether or not the same would, but for this provision, result in the termination of the Sublease by operation of Law);

(c) any lack or invalidity of title or any other defect in title, airworthiness, merchantability, fitness for any purpose, condition, design, or operation of any kind or nature of the Aircraft for any particular use or trade, or for registration or documentation under the Laws of any relevant jurisdiction, or any Total Loss in respect of or any damage to the Aircraft;

(d) any insolvency, bankruptcy, reorganization, arrangement, readjustment of debt, dissolution, liquidation or similar proceedings by or against Head Lessor, Sublessor, Sublessee or any other Person;

(e) any invalidity or unenforceability or lack of due authorization of, or other defect in, the Head Lease or the Sublease;

(f) any Liens or Taxes; and/or

(g) any other cause or circumstance which but for this provision would or might otherwise have the effect of terminating or in any way affecting any obligation of Sublessee under the Sublease. Sublessee acknowledges and agrees that it has inspected and accepted the Aircraft, and that Sublessor is not a manufacturer of or dealer in aircraft and that Sublessor has all of the rights and benefits of a lessor under a lease to which Section 2A-407 of the Uniform Commercial Code of the State of New York applies as provided in such Section 2A-407.

Except as expressly set forth elsewhere in the Sublease, Sublessee hereby waives, to the extent permitted by applicable Law, any and all right which it may now have or which at any time hereafter may be conferred upon it, by statute or otherwise, to terminate, abate, cancel, quit, reduce, defer, suspend or surrender the Sublease or the Aircraft or any obligation imposed upon Sublessee under the Sublease (including payment of Basic Rent).

Each payment of Basic Rent made by Sublessee shall be final. Sublessee will not seek to recover all or any part of any payment of Basic Rent for any reason whatsoever except manifest error.

If for any reason whatsoever the Sublease shall be terminated in whole or in part by operation of Law, except as specifically provided in the Sublease, Sublessor waives all rights (if any) to demand return and surrender of the Aircraft and Sublessee waives all rights (if any) to any termination or diminution in its Basic Rent obligations under the Sublease and nonetheless agrees to pay to Sublessor, an amount equal to each Basic Rent payment at the time such payments would have become due and payable in accordance with the terms of the Sublease had the Sublease not been

terminated in whole or in part and so long as such payments are made and all other terms and conditions of the Sublease are complied with by Sublessee, Sublessor and Sublessee will deem the Sublease to remain in full force and effect and Sublessee shall continue in possession of the Aircraft and Sublessor and Sublessee will continue to have the same rights and obligations under the terms and conditions of the Sublease.

6.9 Risk of Loss or Damage. SUBLESSEE WILL BE RESPONSIBLE FOR ALL RISKS ASSOCIATED WITH (I) THE USE AND OPERATION OF THE AIRCRAFT AND (II) ANY LOSS OF OR DAMAGE TO THE AIRCRAFT FROM THE DELIVERY DATE UNTIL POSSESSION OF THE AIRCRAFT IS RETURNED TO SUBLESSOR ON RETURN AND SUBLESSOR EXECUTES AND DELIVERS THE ACKNOWLEDGEMENT CONTEMPLATED BY SECTION 16.4. If the Aircraft is requisitioned by any Governmental Entity during the Term, then, unless and until the Aircraft becomes a Total Loss: (a) the Term will continue, and Sublessee will continue to fulfill all its obligations under this Agreement; and (b) Subject to Section 19, Sublessee will, during the Term, be entitled to all requisition hire paid to Sublessor or to Sublessee on account of such requisition. The parties agree that Sublessor is not obligated under this Sublease to supply a substitute aircraft, engine or part if the Aircraft, the Airframe, any Engine or any Part suffers a Total Loss or is otherwise damaged, rendered unfit for use, grounded, hijacked, confiscated, seized, requisitioned, restrained or appropriated, including at any time during which the ATSA is in effect with respect to the Aircraft. The ATSA will control with respect to Sublessor's ultimate responsibility (including through one of Sublessor's Affiliates), if any, in connection with any such event.

6.10 Subordination. This Sublease is subject and subordinate to the Head Lease in all respects, and the rights of the Sublessee hereunder are subject and subordinated in all respects to the rights of the Head Lessor, the Owner Participant and the Financing Parties. Prior to Delivery, Sublessee agrees and confirms that its rights to possession of the Aircraft will terminate immediately upon the termination or cancellation of the Head Lease, and that it will redeliver the Aircraft to Head Lessor upon notification from Head Lessor that an Event of Default under the Head Lease has occurred and is continuing, and that Head Lessor has, as a result thereof, terminated or cancelled Sublessor's right to possession of the Aircraft under the Head Lease. Head Lessor, Owner Participant and any Financing Party will be a third-party beneficiary of this Section 6.10.

6.11 Notwithstanding any of the provisions of this Article 6, nothing in this Sublease will act to shift from Sublessor to Sublessee, or vice versa, any of the financial obligations relating to maintenance obligations assumed by Sublessor and Sublessee, respectively, under the ATSA.

## **7. Maintenance and Modifications.**

### **7.1 Maintenance of the Aircraft; ADs.**

7.1.1 General. From and after the Delivery and until the Return Date, except as otherwise set forth in this Agreement (or, with respect to expense, the ATSA), Sublessee, will service, repair, maintain, overhaul, check or cause the same to be done to the Aircraft, by an Authorized Maintenance Provider in accordance with the Maintenance Program and in such operating condition as may be necessary to enable the airworthiness certification



of the Aircraft to be maintained in good standing at all times pursuant to the requirements of the applicable Aviation Authority. The cost and expense of any such work will be for Sublessee to the extent the responsibility for such expense is not allocated to Sublessor under the ATSA.

7.1.2 AD Compliance. From and after the Delivery and until the Return Date, Sublessee will ensure that the Aircraft complies with all applicable Regulations and the standards stipulated by FAR Part 121 and in a manner to maintain all warranty and service life policies, and Sublessee will also ensure that, at Sublessor's cost, the Aircraft complies with the requirements of all ADs and all service bulletins designated by the state of design or State of registry as "mandatory," which are required to be carried out from and after the Delivery and until the Return Date or within the AD Compliance Period. The cost and expense of any such compliance will be for Sublessee to the extent the responsibility for such expense is not allocated to Sublessor under the ATSA.

## 7.2 Maintenance of the Aircraft Documents.

7.2.1 From the Delivery until the Return Date, Sublessee, at its own expense, will maintain and update (or will cause to be maintained and updated), in the English language, all Aircraft Documents created from and after the Delivery Date as required by applicable Laws and by the Regulations of the applicable Aviation Authority. Sublessee will at all times cause the Aircraft Documents to be stored at a location disclosed to and reasonably acceptable to Sublessor and shall provide access to them to the Sublessor (such access to be provided online to the extent applicable). Sublessee acknowledges and agrees that the Aircraft Documents, including all additions, supplements and replacements thereto or thereof constitute part of the Aircraft, are leased to Sublessee hereunder and are the sole and exclusive property of the Head Lessor.

7.2.2 When incorporating ADs, service bulletins, modifications, repairs, or any other engineering changes to the Aircraft, Sublessee will revise (or cause to be revised) the customized documentation for the Aircraft in order to incorporate and reflect such ADs, service bulletins, modifications, or repairs, as applicable. These changes may be incorporated by methods such as external supplements, or other means acceptable to the applicable Aviation Authority for operational purposes.

7.3 Authorized Maintenance Provider. All maintenance on the Airframe, Engines and Parts will be performed by an Authorized Maintenance Provider.

## 7.4 Equipment Changes.

7.4.1 Sublessee will not make any modification or addition to the Aircraft (each an "Equipment Change"), except for an Equipment Change which:

- (a) is expressly permitted or required by the Sublease; or
- (b) (A) has the prior written approval of Sublessor (which shall not be unreasonably withheld) if it is a "major change" (as defined in the FAR) and (B) in all events does not diminish the condition, utility, airworthiness or value of the Aircraft.

7.4.2 So long as no Event of Default has occurred and is continuing, Sublessee may, subject to any applicable Regulations, remove or reverse any Equipment Change provided that the Equipment Change is not required pursuant to the terms of the Sublease or to maintain the insurance required by Section 11 and removal or reversal does not diminish the value, utility, airworthiness or condition of the Aircraft assuming that such Equipment Change was not made and that the Aircraft is maintained in accordance with the Sublease. Furthermore, Sublessor may require (at Sublessor's expense) Sublessee to remove or reverse any Equipment Change prior to Return so that, on the Expiration Date the Aircraft is restored to the condition it was in prior to that Equipment Change. Any Equipment Change not so removed or reversed becomes the property of Head Lessor at the Expiration Date.

7.4.3 Title on an Equipment Change. Title to any equipment that is installed on the Airframe shall, except in the case of an engine or a temporary replacement of a Part in accordance with Section 6.2.4, vest in Head Lessor solely by virtue of its attachment to the Airframe or an Engine and it shall then be subject to the Head Lease, the Sublease and, if applicable, the Financing Documents, as if it were attached to the Aircraft at Delivery. In the case of any replacement of an Engine, and otherwise if so requested by Sublessor, Sublessee will provide a properly executed bill of sale or similar instrument to evidence the vesting of good and marketable title, free and clear of any Lien (except Permitted Liens), to any such Replacement Engine or other equipment in Sublessor and all documents required under the Financing Documents and will take such steps as Sublessor may request to record and perfect such interests. After Sublessor has determined that Sublessee has permanently replaced an Engine in accordance with Section 6.2.2 and this Section 7.4.3, Sublessor will, without recourse or warranty (except as to the absence of Sublessor's Liens), transfer to Sublessee all of Sublessor's rights to the engine that has been replaced, on an AS IS, WHERE IS basis, and will at Sublessee's expense provide a bill of sale or similar instrument as Sublessee may reasonably request to evidence such transfer. The parties will execute, deliver and file as appropriate amendments and supplements to the Sublease and Financing Documents required to evidence any replacement of an Engine and, where the Cape Town Convention applies, cooperate with the prompt registration of the transfer of titles at the International Registry. Sublessee shall indemnify Head Lessor, Sublessor, Owner Participant and each other Tax Indemnitee for all fees, expenses and Taxes incurred by Head Lessor, Sublessor, Owner Participant or any other Tax Indemnitee in connection with any such transfer.

7.5 Summary of Flight Hours, Cycles, Technical Information.

7.5.1 Sublessee, at its own expense, will, within [\*\*\*] Business Days after the end of each calendar month of the Term and on the Return, provide (or cause to be provided) to Sublessor written summaries (the "Written Summaries") of the Flight Hours and Cycles accrued on the Airframe and Engines occurring during the previous calendar month, in the form reasonably required by Sublessor.

7.5.2 Sublessee will give Sublessor not less than [\*\*\*] days' prior written notice of the anticipated time and location of all partial or complete Major Checks or scheduled Engine shop visits.

7.5.3 provide Sublessor with such other information concerning the location, condition, use and operation of the Aircraft as Sublessor may from time to time reasonably request;

7.5.4 promptly notify Sublessor of the removal of any Engine from the Airframe for a period of more than one week or for the purpose of Engine Refurbishment;

7.5.5 All information furnished by Sublessee to Sublessor concerning monetary amounts (whether in the Written Summaries or otherwise) will be denominated in Dollars.

#### 7.6 Access; Inspections.

7.6.1 Sublessee will permit Head Lessor's, Sublessor's, Owner Participant's and the Financing Parties' representatives access to the Aircraft at any reasonable time. Unless a Default has occurred and is continuing, any such Person will give Sublessee at least [\*\*\*] days' prior notice and will seek to ensure that it does not result in an unreasonable disruption to the scheduled operation of the Aircraft. Sublessee shall comply with the reasonable requests of Head Lessor's, Sublessor's, Owner Participant's and the Financing Parties' representative. Such inspection may include the opening of panels or bays so long as they can be opened without the removal of bolts.

7.6.2 As between the requesting party and the Sublessee, the cost of conducting a visit shall be borne by the requesting party, unless an Event of Default has occurred and is continuing, in which case such cost shall be borne by Sublessee.

7.6.3 No liability or obligation will be incurred by Head Lessor, Sublessor, Owner Participant, Financing Parties' Representative or the Financing Parties, as the case may be, by reason of non-exercise by any of them of the rights referred to in this Section 7.6.3. Any inspection of the Aircraft or an Engine by Head Lessor, Sublessor, Owner Participant, Financing Parties' Representative or the Financing Parties, as the case may be, shall be for such Person's benefit only, and there shall be no inference or implication therefrom that Sublessee is complying with its obligations under the Sublease, and a failure by Sublessor, Owner Participant, Financing Parties' Representative or the Financing Parties, as the case may be, to notify Sublessee of any non-compliance of its obligations that may be observed during any such inspection shall not constitute a waiver of any Default or Event of Default arising from such non-compliance.

7.6.4 Sublessor agrees to exercise its right to inspect the Aircraft no more frequently than once per year, excluding inspections related to any (i) Default; (ii) potential transfer under Section 12.2; (iii) damage to the Aircraft or (iv) maintenance work which is likely to be the subject of a claim for a Sublessor cost contribution.

7.6.5 Sublessee will reasonably assist any person designated by Sublessor to conduct any inspection pursuant to this Section 7.6. Sublessor or any person entitled to do so pursuant to this Section 7.6 will not incur any liability or obligation by reason of not making an inspection and no failure by Sublessor to make such inspection will lessen any obligation of Sublessee under this Agreement, including Sublessee's obligations under this Section 7. In addition, Sublessee will permit one of Sublessor's technical representatives to be present at any heavy maintenance being conducted on the Aircraft or Engines, subject to compliance with the applicable maintenance facility's security requirements and provided such presence does not interfere with or delay the performance and completion of such maintenance.

7.6.6 Records. Sublessee will keep all Aircraft Documents in a manner that meets the requirements of applicable Laws (including FAR 91.417) and the Maintenance Program, and Sublessee shall provide access to them to Sublessor (such access can be online to the extent applicable). Sublessee acknowledges and agrees that the Aircraft Documents, including all additions, supplements and replacements thereto or thereof constitute part of the Aircraft, are leased to Sublessee hereunder and are the sole and exclusive property of the Head Lessor.

7.6.7 Sublessor Not Obligated. Except as otherwise expressly provided in this Agreement or in the ATSA, Sublessor will have no obligation whatsoever under this Sublease to service, repair, maintain, check, or cause the same to be done to the Aircraft, or to keep the Aircraft in an airworthy condition after the Delivery and until the Return Date.

## 8. Taxes.

### 8.1 General:

8.1.1 Except as provided in Section 8.3, Sublessee will on demand pay and indemnify each Tax Indemnitee against any and all Taxes levied or imposed against or upon or payable by such Tax Indemnitee or Sublessee and arising from, with respect to or in connection with the transactions pursuant to the Sublease, including all Taxes relating or attributable to Sublessee, the Sublease or the Aircraft, directly or indirectly, in connection with the importation, exportation, registration, ownership (but only to the extent relating to or attributable to or arising as a result of the possession, operation, use or maintenance of the Aircraft by Sublessee), leasing, sub-leasing, purchase, delivery, possession, use, operation, repair, maintenance, modification, overhaul, transportation, landing, storage, presence, sale or other transfer or redelivery of the Aircraft or any part thereof or any rent, receipts, insurance proceeds, income, indemnification payment or other amounts arising therefrom, or the making of any Equipment Change or the permanent replacement of any Engine, except to the extent that such Taxes are Sublessor Taxes, (collectively, "Sublessee Taxes").

8.1.2 All Taxes indemnified pursuant to this Section 8.1 shall be paid by Sublessee directly to the appropriate taxing authority (to the extent permitted by applicable Law) at or before the time prescribed by applicable Law or if not so permitted, to the applicable Tax Indemnitee. After any payment by Sublessee of any Tax directly to a taxing authority, Sublessee shall furnish to Sublessor, on request, a copy of a receipt for

Sublessee's payment of such Tax (certified by a responsible officer of Sublessee) or if such receipt is not available, such other evidence of payment of such Tax as is reasonably obtainable by Sublessee and reasonably acceptable to Sublessor, which evidence may be provided by certification of such payment by a responsible officer of Sublessee.

8.1.3 Any amount payable by Sublessee to a Tax Indemnitee pursuant to this Section 8 shall be paid within [\*\*\*] days after receipt of a written demand therefore from the relevant Tax Indemnitee accompanied by a written statement describing in reasonable detail the basis for such indemnity and the computation of the amount so payable, provided that if an amount of any indemnified Tax is being contested in accordance with Section 8.4 and Sublessee shall have duly performed (and shall continue to perform) all its obligations under Section 8.4 with respect to such contest, then payment of the indemnity with respect to such Tax under this Section 8.1 shall, at Sublessee's election, be deferred until the date the contest has been completed.

## 8.2 Sales and Use Taxes:

8.2.1 Without limiting Section 8.1 above, Sublessee shall pay to Sublessor (or, if permitted by applicable Law and if requested by Sublessor, Sublessee shall pay to the relevant tax authority for the account of Sublessor):

(a) all sales, use, rental, value added, turnover, goods and services and similar taxes except to the extent that such Taxes are Sublessor Taxes ("Sales Taxes") required to be paid to the applicable tax authority of the relevant jurisdiction in which the Delivery Location and/or the Habitual Base is located and/or the state of incorporation of the Head Lessor, with respect to the lease of the Aircraft to Sublessee pursuant to the Sublease unless Sublessee delivers to Sublessor on or prior to the Delivery Date such exemption certificate or other document as may be required by applicable Law to evidence Sublessor's entitlement to exemption from all Sales Taxes imposed by each such jurisdiction with respect to the lease of the Aircraft pursuant to the Sublease; and

(b) all Sales Taxes required to be paid to the tax authority of any jurisdiction in which the Aircraft may be used, operated or otherwise located from time to time except to the extent Sublessee is exempt from Sales Taxes and delivers to Sublessor such exemption certificates or other documents as may be required by applicable Law to evidence Sublessee's entitlement to exemption from all Sales Taxes imposed by such jurisdiction with respect to the lease of the Aircraft pursuant to the Sublease.

(c) Sublessee will cooperate with Sublessor in connection with the preparation and filing of any exemption application or similar document that is reasonably necessary or desirable under applicable Law to avoid the imposition of any Sales Taxes with respect to the transactions contemplated by the Sublease;

(d) The specific obligations with respect to sales and use taxes set forth in this Section 8.2 are in addition to, and are not in substitution for, Sublessee's obligation to indemnify for sales and use taxes pursuant to Section 8.

8.3 Sublessor Taxes. Sublessee is not required to indemnify Sublessor or Owner Participant under Section 8.1 or 8.2 to the extent that the Tax arises because of:

8.3.1 the fraud, bad faith, willful misconduct or gross negligence of any Tax Indemnitee;

8.3.2 a Sublessor's Lien;

8.3.3 a Tax liability imposed on or payable by any Tax Indemnitee has which would have arisen even if the Sublease had not been entered into;

8.3.4 a Tax liability charged on any Tax Indemnitee's net income, profits or gains by any Governmental Entity in the United States or any jurisdiction where any Tax Indemnitee is resident for Tax purposes; but excluding any Tax that is a Sales Tax or that is imposed by any government or taxing authority of any jurisdiction if and to the extent that such Tax results from (x) the use, operation, presence, registration or location of the Aircraft, the Airframe, any Engine or any Part in the jurisdiction imposing the Tax, or (y) the situs of organization, any place of business or any activity of Sublessee or any other Person not related to such Tax Indemnitee having use, possession or custody of the Aircraft, the Airframe, any Engine or any Part in the jurisdiction imposing the Tax;

8.3.5 a Tax liability charged with respect to the period, or an event occurring, (x) prior to the Delivery Date (except where the Aircraft has been purchased from Sublessee (or an Affiliate of Sublessee) and is to be leased back to Sublessee under the Sublease) or (y) after the Expiration Date unless such Tax is attributable to any act, omission, event or circumstance which occurred during the Term and would not have constituted a Sublessor Tax had it arisen during the Term;

8.3.6 a Tax liability imposed as a result of any connection between any Tax Indemnitee and the jurisdiction imposing the Tax that is unrelated to the transactions contemplated by the Sublease or the use or operation of the Aircraft by Sublessee or any other Person not related to such Tax Indemnitee, or the location or registration of the Aircraft by Sublessee or any other Person not related to such Tax Indemnitee and for which the jurisdictional connection necessary for the imposition of the Tax would have existed even if the transactions contemplated by the Sublease had not been entered into;

8.3.7 a Tax liability imposed in connection with the voluntary sale, transfer, assignment (whether legal or equitable) or other disposition (including an involuntary disposition pursuant to a bankruptcy or similar proceeding involving such Tax Indemnitee) by any Tax Indemnitee or any or all of its rights, title and interest in or with respect to the Aircraft, the Airframe, any Engine or any Part, the Sublease or any other Operative Document, except in connection with or resulting from an Event of Default or Total Loss;

8.3.8 a Tax liability imposed on such Tax Indemnitee due to the failure of any Tax Indemnitee to file any relevant tax return or tax computation that such Tax Indemnitee was obliged to file by the applicable Law in its jurisdiction of incorporation unless relating to a Tax otherwise indemnified pursuant to this Section 8.3 and imposed as a result of Sublessee's breach of Section 8.4.4;

8.3.9 a change by any Tax Indemnitee of its principal place of business, participating office, jurisdiction of organization or tax residence;

8.3.10 a Tax liability imposed on or payable by any Tax Indemnitee that would not have been imposed or payable but for the existence of any loan or financing provided by the Financing Parties and any security documents entered into in connection therewith except Taxes imposed as a result of (A) the fraud, bad faith, gross negligence or willful misconduct of Sublessee or any other user of the Aircraft, or (B) a breach by Sublessee of any of its representations, warranties or covenants under the Sublease; or

8.3.11 is a Tax for which Sublessor or any other Tax Indemnitee has expressly agreed to be responsible under any other Operative Document.

(collectively "Sublessor Taxes").

#### 8.4 Tax Contest

8.4.1 If any Tax Indemnitee receives a written claim for any Tax for which Sublessee would be required to pay an indemnity pursuant to Section 8.1 or 8.2, such Tax Indemnitee shall notify Sublessee promptly of such claim, provided that any failure to provide such notice will not relieve Sublessee of any indemnification obligation pursuant to Section 8.1 or 8.2. If requested by Sublessee in writing within [\*\*\*] days after receipt of such notice, the Tax Indemnitee shall, upon receipt of indemnity satisfactory to it and an opinion of independent tax counsel selected by the Tax Indemnitee and reasonably satisfactory to Sublessee, that a reasonable basis exists for such contest, and at the expense of Sublessee (including all costs, expenses, legal including tax counsel referred to above and accountants' fees and disbursements, and penalties, interest and additions to tax incurred in contesting such claim) in good faith contest or (if permitted by applicable Law and the contest does not relate to income Taxes) permit Sublessee to contest such claim by (i) resisting payment thereof if practicable and appropriate, (ii) not paying the same except under protest if protest is necessary and proper, or (iii) if payment is made, using reasonable efforts to obtain a refund of such Taxes in appropriate administrative and judicial proceedings. A Tax Indemnitee shall determine the method of any contest conducted by it and (in good faith consultation with Sublessee) control the conduct thereof. Sublessee shall determine the method of any contest conducted by Sublessee and (in good faith consultation with a Tax Indemnitee) control the conduct thereof. Sublessee shall pay in full all payments of Basic Rent and other amounts payable pursuant to the Sublease, without reduction for or on account of any Tax, while such contest is continuing. A Tax Indemnitee shall not be required to contest, or to continue to contest, a claim for Taxes under this Section 8.4 if (w) in the case of a contest related to income Taxes, the amount of Taxes at issue is less than \$[\*\*\*], or (x) such contest would (or could reasonably be

expected to) result in a risk of criminal penalties or a material risk of a sale, forfeiture or loss of, or the imposition of a Lien (other than a Permitted Lien) on, the Aircraft, or (y) Sublessee shall not have furnished, at Sublessee's expense, the opinion of independent tax counsel referred to above, or (z) a Default or an Event of Default shall be continuing. If a Tax Indemnitee contests any claim for Taxes by making a payment and seeking a refund thereof, then Sublessee shall advance to such Tax Indemnitee, on an interest-free basis, an amount equal to the Taxes to be paid by the Tax Indemnitee in connection with the contest and shall indemnify the Tax Indemnitee on an after-Tax basis for any material adverse tax consequences to the Tax Indemnitee of such interest-free advance. Upon the final determination of any contest pursuant to this Section 8.4 in respect of any Taxes for which Sublessee shall have made an advance to a Tax Indemnitee in accordance with the immediately preceding sentence, the amount of Sublessee's obligation shall be determined as if such advance had not been made; and any indemnity obligation of Sublessee to the Tax Indemnitee under this Section 8.4 and the Tax Indemnitee's obligation to repay the advance will be satisfied first by setoff against each other, and any difference owing by either party shall be paid within [\*\*\*] days after such final determination.

8.4.2 Each Tax Indemnitee agrees that it shall, as soon as reasonably practicable after it becomes aware of any circumstances which shall, or could reasonably be expected to, become the subject of a claim for indemnification by such Tax Indemnitee pursuant to Section 8.1 or 8.2 or require Sublessee to indemnify or pay an amount under Section 8.9 or make an increased payment pursuant to Section 5.6, notify Sublessee in writing accordingly, provided that a failure to so notify will not diminish, or relieve Sublessee of, any obligations hereunder or diminish the rights of the Tax Indemnitee. Similarly, Sublessee shall, as soon as reasonably practicable after it becomes aware of any circumstances which shall, or would reasonably be expected to, result in a claim for indemnification under Sections 8.1 or 8.2 or require Sublessee to indemnify or pay an amount under or Section 8.9 or make an increased payment pursuant to Section 8.8, notify Sublessor in writing accordingly. Provided no Event of Default is then continuing, Sublessor and Sublessee shall then consult with one another in good faith, for a period of up to [\*\*\*] days in order to determine what action (if any) may reasonably be taken to mitigate or avoid the incidence of the relevant Taxes (and Sublessee shall pay Sublessor's reasonable and documented out of pocket expenses (including legal fees) in relation to any such consultations). Sublessor shall then take such steps as it agreed during such consultation to take for that purpose, provided always that (A) it is fully indemnified by Sublessee to Sublessor's satisfaction (acting reasonably) for so doing, (B) it shall not be required to take, or omit to take, any action, if the effect of such action or omission would reasonably be expected to adversely affect Sublessor or would be contrary to applicable Law, (C) Sublessor shall not be responsible for or obliged to achieve any particular result from the taking of such steps and (D) nothing in this Section 8.4.2 shall require Sublessor to disclose or interfere with its tax affairs.

8.4.3 If any Tax Indemnitee obtains a refund or reimbursement of all or any part of any Taxes for which a full indemnity was paid by Sublessee, the Tax Indemnitee shall pay Sublessee the amount of such refund or reimbursement, reduced by any Taxes imposed on it on receipt or accrual of such refund or reimbursement and increased by any Taxes saved by it by reason of the deductibility of such payment by such Tax Indemnitee. If, in



addition to such refund or reimbursement, a Tax Indemnitee receives an amount of interest on such refund or reimbursement, the Tax Indemnitee shall pay to Sublessee the portion of such interest which is fairly attributable to such refund, reduced by any Taxes imposed on the Tax Indemnitee on receipt or accrual of such interest and increased by any Taxes saved by reason of the deductibility of such payment by the Tax Indemnitee. A Tax Indemnitee shall not be required to make any payment to Sublessee pursuant to this Section 8.4 if, and for so long as, a Default or an Event of Default shall have occurred and be continuing. So long as a Default or an Event of Default shall not have occurred and be continuing, Sublessee shall be entitled set off any such amount owed by Sublessor to Sublessee against any amounts then owed by Sublessee to Sublessor. A Tax Indemnitee shall, following the cure by Sublessee or waiver by Sublessor in writing of any Default or Event of Default that was continuing when the Sublessor was otherwise obligated to make a payment to Sublessee pursuant to this Section 8.4, such payment shall be made to Sublessee or Sublessee shall be entitled to set off any such amount owed to it by Sublessor.

8.4.4 Any Tax Indemnitee in its sole discretion (by written notice to Sublessee) may waive its rights to indemnification pursuant to Section 8.1 or 8.2 with respect to any claim for any Tax and may refrain from contesting or continuing the contest of such claim, in which event Sublessee shall have no obligation to indemnify such Tax Indemnitee for the Taxes that are the subject of such claim. If any Tax Indemnitee agrees to a settlement of any contest conducted pursuant to this Section 8.4 without the prior written consent of Sublessee, which consent shall not be unreasonably withheld, then such Tax Indemnitee shall be deemed to have waived its rights to the indemnification provided for in Section 8.1 or 8.2 with respect to the Tax liability accepted in such settlement.

8.4.5 Information:

(a) If Sublessee is required by any applicable Law, or by any third party, to deliver any report or return in connection with any Taxes for which Sublessee would be obligated to indemnify a Tax Indemnitee under the Lease, Sublessee will complete the same and, on request, supply a copy of the report or return to Sublessor.

(b) If any report, return or statement is required to be made by a Tax Indemnitee with respect to any Tax for which there is an indemnity obligation of Sublessee under the Lease, and Sublessee knows of, or reasonably should have known of, such return, report or statement, Sublessee will promptly notify Sublessor of the requirement and:

(i) if permitted by applicable Law, make and timely file such report, return or statement (except for any report, return or statement that Sublessor has notified Sublessee that a Tax Indemnitee intends to prepare and file), prepare such return in such manner as will show Sublessor as sublessor of the Aircraft and the beneficial ownership of the Aircraft in Owner Participant if required or appropriate, and provide Sublessor upon request a copy of each such report, return or statement filed by Sublessee, or

(ii) if Sublessee is not permitted by applicable Law to file any such report, return or statement, Sublessee will prepare and deliver to Sublessor a proposed form of such report, return or statement within a reasonable time prior to the time such report, return or statement is to be filed.

8.4.6 Sublessee will provide such information and documents as Sublessor may reasonably request to enable any Tax Indemnitee to comply with its tax filing, audit and litigation obligations. A Tax Indemnitee will provide such information or documents, at Sublessee's expense, that Sublessee does not otherwise have or that Sublessee may reasonably request and which are necessary to enable Sublessee to comply with its obligations under the Sublease (including Sections 8.1, 8.2 and 8.8 of this Sublease).

8.5 Sublessee's Indemnities Payable on After-Tax Basis; Payments in Respect of Tax Benefits. Sublessee agrees that, with respect to any payment or indemnity to Sublessor under this Section 8, Sublessee's indemnity obligations will include an amount necessary to hold Sublessor harmless from all Sublessee Taxes required to be paid by Sublessor with respect to the receipt or accrual of such payment or indemnity (including any payment by Sublessor of any Sublessee Taxes in respect to any indemnity payments received or receivable under this Section 8). If: (a) any Taxes are required to be deducted or withheld by Sublessee from any amounts due to Sublessor under this Agreement and (b) Sublessee is required to indemnify Sublessor against such Taxes pursuant to this Section 8, then Sublessee will, at the time of paying the amounts due to Sublessor, pay to Sublessor such additional amounts as may be necessary in order that the net amount of such payment, after deduction or withholding for such Taxes, will be equal to the amount Sublessor would have received if such Taxes had not been deducted or withheld.

8.6 Payment of Tax. Any amount payable by Sublessee pursuant to Section 8 will be paid to Sublessor or, if so directed by Sublessor, directly to the relevant taxing authority, within [\*\*\*] days after receipt by Sublessee of a written demand for same from Sublessor accompanied by a written statement describing in reasonable detail the Taxes that are the subject of and basis for such payment or indemnity, as applicable, and the computation of the amount so payable.

8.7 Tax Exemptions, Rebates, and Credits. Sublessor and Sublessee agree to provide any assistance reasonably requested by the other Party in obtaining tax exemptions, rebates, or credits for any Taxes.

#### 8.8 Withholding and Tax Credit

8.8.1 Withholding. Sublessee shall not deduct any amount from any of its payments under the Sublease, for or on account of any Taxes, unless it is required by Law to do so, in which case Sublessee shall notify Sublessor and shall:

(a) deduct the minimum amount necessary to comply with the Law;

(b) without duplication of clause (iii) below, pay Sublessor an extra amount so that Sublessor receives a net amount on the relevant payment date that is equal to the amount that it would have received if the deduction had not been made. The amount of any such payment to Sublessor shall be made so that Sublessor shall be in no worse position than it would have been if the deduction had not applied in the first place;

(c) pay the Tax to the relevant taxing authority according to the relevant Law; and

(d) where available, provide a receipt from the relevant taxing authority (or if such receipt is not available, such other evidence of withholding and payment of the Tax reasonably acceptable to Sublessor).

8.8.2 Tax Credit. If Sublessor or any Indemnitee, in good faith, determines that it has realized a tax benefit (by way of deduction, credit or otherwise) as a result of any payment for which Sublessee is liable under Section 8.8.1, Sublessor or such Indemnitee shall pay to Sublessee as soon as practicable after the tax benefit has been realized (but not before Sublessee has made all payments and indemnities to Sublessor required under this Section 8.8.2) an amount which will ensure that (after taking account of the payment itself) Sublessor or such Indemnitee is in no better and no worse position than it would have been if the deduction had not applied. Nothing in this Section 8.8.2 shall:

(a) interfere with the right of Sublessor or any Indemnitee to arrange its tax affairs in whatever manner it thinks fit in accordance with applicable Law; or

(b) oblige Sublessor or any Tax Indemnitee to disclose any information relating to its Tax affairs or any Tax computations, except to a nationally recognized public accounting firm, mutually agreed between Sublessor and Sublessee, solely to the extent necessary to demonstrate the calculation of such Tax credit.

#### 8.9 Value Added Tax.

8.9.1 For the purposes of this Section 8.9:

(a) “VAT” means value added tax and any goods and services, sales, use, or turnover tax, imposition or levy of a like nature; and

(b) “supply” includes anything on or in respect of which VAT is chargeable.

8.9.2 Sublessee will pay to Sublessor or the relevant taxing authority (without duplication) and indemnify Sublessor against the amount of any VAT chargeable in respect of any supply for VAT purposes under the Sublease. Sublessee shall provide evidence to Sublessor, if available, in respect of any payment it makes of such VAT, and where evidence of payment from the relevant taxing authority is not available, such evidence may be provided by certification of such payment by a responsible officer of Sublessee. The amount of any such payment to Sublessor shall be made so that Sublessor shall be in no worse position than it would have been if the payment had not made in the first place;

8.9.3 Each amount stated as payable by Sublessee under the Sublease is exclusive of VAT (if any).

## 9. Liens.

9.1 Permitted Liens. During the Term, Sublessee will not create or suffer to exist any Lien upon or against the Aircraft or any of its rights under this Agreement, other than the following (“Permitted Liens”):

9.1.1 any lien for Taxes not assessed or, if assessed, not yet due and payable, or being diligently contested in good faith by appropriate proceedings;

9.1.2 any lien of a repairer, mechanic, hangar-keeper, airport, air navigation authority or other similar lien arising in the ordinary course of business by operation of Law in respect of obligations which are not overdue or are being diligently contested in good faith by appropriate proceedings;

9.1.3 liens or other Liens (other than liens for Taxes) arising out of any judgment or award (i) for [\*\*\*] days after the entry of such judgment or award, or (ii) during an appeal or review regarding such judgment or award with respect to which there shall have been secured a stay of execution pending such appeal or review;

9.1.4 any Lien arising from the Sublease or “Operative Documents” as defined under the Head Lease;

9.1.5 any Sublessor’s Lien; and

9.1.6 the rights of others under any parts pooling arrangements or other arrangements to the extent expressly permitted under Section 6.2;

but only if (in the case of (a), (b) and (c)) (i) adequate reserves have been provided for by Sublessee for the payment of such Taxes, obligations or judgment; and (ii) such proceedings, or the continued existence of the lien, do not give rise to any material risk of the sale, detention, forfeiture or other loss of the Aircraft or any interest therein or of criminal liability or material civil liability on the part of Head Lessor, Sublessor or Owner Participant.

9.2 Other Liens. All Liens excepted above under Section 9.1.1, 9.1.2 and 9.1.3 will be cleared by Sublessee promptly in the ordinary course of business and not later than the Return. If at any time during the Term a Lien (other than a Permitted Lien) will be created or suffered to exist by Sublessee, or be levied upon or asserted against the Aircraft, or if any person or entity should assert any Lien (other than a Permitted Lien) on any right of Sublessee under this Agreement, Sublessee will notify Sublessor, and Sublessee will cause such Lien forthwith to be discharged by bond or otherwise unless Sublessor will have otherwise consented in writing. If Sublessee fails to discharge any Lien (other than Permitted Liens), Sublessor may do so, and Sublessee will pay to Sublessor on demand the amount paid by Sublessor in connection with such discharge, together with Sublessor’s losses, costs, and expenses, including reasonable legal fees and expenses. The obligations set forth in this Section 9 will survive the Expiration or Termination of this Agreement.

## 10. Indemnification.

10.1 GENERAL INDEMNITY. EXCEPT AS PROVIDED IN SECTION 10.2 BELOW, SUBLESSEE AGREES TO ASSUME LIABILITY AND PAY FOR AND TO INDEMNIFY EACH OF THE INDEMNITEES AGAINST AND AGREES TO PAY ON DEMAND ANY AND ALL LOSSES WHICH AN INDEMNITEE MAY SUFFER OR INCUR AT ANY TIME, WHETHER DIRECTLY OR INDIRECTLY, ARISING OUT OF, RELATED TO OR IN ANY WAY CONNECTED WITH:

10.1.1 THE OWNERSHIP, MAINTENANCE, REPAIR, POSSESSION, SALE OR OTHER TRANSFER OF OWNERSHIP OR POSSESSION, IMPORT, EXPORT, REGISTRATION, STORAGE, MODIFICATION, LEASING (INCLUDING SUB-LEASING OR WET LEASING), INSURANCE, INSPECTION, TESTING, DESIGN, USE, OPERATION, CONDITION, SECURITY INTERESTS (OTHER THAN SUBLESSOR'S LIENS) OR OTHER MATTERS RELATING TO THE AIRCRAFT, ANY ENGINE OR PART OR THE SUBLEASE (REGARDLESS OF WHETHER IN THE AIR OR ON THE GROUND, AND REGARDLESS OF WHETHER SUCH LOSSES ARE BASED ON STRICT LIABILITY IN TORT, ANY ACT OR OMISSION, INCLUDING THE NEGLIGENCE, OF ANY INDEMNITEE, OR OTHERWISE); OR

10.1.2 ANY BREACH BY SUBLESSEE OF ANY OF ITS OBLIGATIONS UNDER THE SUBLEASE; OR

10.1.3 THE DESIGN, TESTING OR USE OF ANY ARTICLE OR MATERIAL IN THE AIRCRAFT, ANY ENGINE OR ANY PART OR ITS OPERATION, INCLUDING ANY DEFECT IN DESIGN AND REGARDLESS OF WHETHER IT IS DISCOVERABLE, AND ANY INFRINGEMENT OF PATENT, COPYRIGHT, TRADEMARK, DESIGN OR OTHER PROPRIETARY RIGHT CLAIMED BY ANY PERSON OR A BREACH OF ANY OBLIGATION OF CONFIDENTIALITY CLAIMED TO BE OWED TO ANY PERSON.

FOR THE AVOIDANCE OF DOUBT, THE REFERENCE TO "OWNERSHIP" IN SECTION (i) SHALL NOT REQUIRE SUBLESSEE TO INDEMNIFY ANY INDEMNITEE IN RESPECT OF (Y) ANY DEFECT IN HEAD LESSOR'S TITLE TO THE AIRCRAFT OR (Z) ANY DECLINE IN RESIDUAL VALUE OF THE AIRCRAFT IF SUBLESSEE SHALL HAVE FULLY COMPLIED WITH ITS OBLIGATIONS UNDER THE SUBLEASE.

10.2 Exceptions. Sublessee is not required to indemnify any particular Indemnitee (provided that each Indemnitee and their Affiliates, officers, directors and employees shall be treated as a single Indemnitee) under this Section 10, to the extent a particular Loss is:

10.2.1 caused solely by the gross negligence or willful misconduct of that Indemnitee, other than gross negligence imputed to that Indemnitee by reason of its interest in the Aircraft or the Sublease;

10.2.2 caused solely by any Indemnitee's material breach of the Sublease or other Operative Documents to which it is a party which does not result from a Default;

10.2.3 related to any Taxes (but without prejudice to any Indemnitee's rights under any other provision of the Sublease or the ATSA relating to Taxes);

10.2.4 caused solely by an event which occurs before the commencement of the Term (except where (aa) the Loss is suffered during the Term as a result of a pre-Delivery defect in or otherwise arises out of or relates to or is any way connected with the manufacture or design, of the Aircraft or (bb) the Aircraft has been purchased from Sublessee (or an Affiliate of Sublessee) and is to be leased back to Sublessee under the Sublease);

10.2.5 caused solely by an event that occurs after the redelivery of the Aircraft to Sublessor in compliance with the Sublease and is not attributable to any act, omission, event or circumstance occurring prior to such redelivery;

10.2.6 caused solely as a result of any sale, assignment, transfer or other disposition (whether voluntary or involuntary) by such Indemnitee of the Aircraft or any Engine or any interest therein that is not a replacement thereof under the Sublease or is otherwise not contemplated under the Sublease, and unless such sale, assignment, transfer or other disposition has resulted from or occurred following an Event of Default;

10.2.7 consists of normal administrative costs and expenses or usual operating and overhead costs and expenses of such Indemnitee (but excluding any such costs or expenses resulting from the occurrence of any Default);

10.2.8 consists of costs or expenses for which Sublessor has expressly agreed to be responsible under any other provision of the Sublease or the ATSA;

10.2.9 is a Loss for which Sublessor or any other Indemnitee has expressly agreed to be responsible under any other provision of this Agreement or any other Operative Document; or

10.2.10 is indemnified against elsewhere in this Agreement or any other Operative Document.

10.3 Continuance. The indemnities contained in the Sublease will continue in full force and effect following the Expiration Date notwithstanding any breach or repudiation by Sublessor or Sublessee of the Sublease or any termination or cancellation of the leasing of the Aircraft.

## 11. Insurance.

11.1 Aviation Third Party Legal Liability Insurance. As of the Delivery Date and continuing for a period of [\*\*\*] following the Return Date, Sublessee will carry at its expense (or will cause to be carried) through the London or New York insurance markets with insurers of internationally recognized standing, aviation legal liability insurance in respect of the Aircraft in amounts not less than the Minimum Liability Coverage combined single limit for bodily injury and property damage each occurrence (and in the aggregate as respects aviation products/completed operations and third party liability war and allied perils), and subject to customary sub-limits for non-aviation coverages. Such insurance will include third party legal

liability including passenger liability, liability war and allied perils (in the scope provided by AVN52E as in effect on the Delivery Date), property damage liability (including cargo, and mail liability), premises liability, products/completed operations liability, and contractual liability insurance in the amounts set forth in Appendix B. All such insurance will be in form and substance reasonably satisfactory to Sublessor. Sublessee covenants that any insurance policies carried in accordance with this Section 11.1 and any policies taken out in substitution or replacement for any of such policies will: (a) be endorsed to name each Indemnitee and such other parties as Sublessor may from time to time reasonably designate by notice to Sublessee as additional insureds for their respective interests, each as to itself only, no operational interest (without imposing on any such Person any obligation imposed on the insured, including liability to pay any calls, commissions or premiums) with respect to the Aircraft (hereinafter each an "Additional Insured"); (b) provide that in respect of the interests of any Additional Insured in such policies, the insurance will not be invalidated by any act or omission of Sublessee (including misrepresentation and non-disclosure), except that the Additional Insured so protected has not caused, contributed to or knowingly condoned the said act or omission; (c) provide that insurers waive all rights of subrogation against the Additional Insureds; (d) provide that, if such insurance is canceled or allowed to lapse for any reason whatsoever, or if any material change is made in such insurance that adversely affects the interest of any Additional Insured, such cancellation, lapse or change will not be effective as to any Additional Insured for [\*\*\*] days ([\*\*\*] days for nonpayment of premiums and [\*\*\*] days, or such other period as is then customarily obtainable in the industry, in the case of any war and allied perils liability coverage) after the giving of written notice from such insurers or Sublessee's appointed insurance broker to Sublessor; (e) be primary without right of contribution from any other insurance maintained by any Additional Insured; (f) provide a severability of interests provision applicable to each insured and Additional Insured under the policy such that all of the provisions of the insurance required under this Agreement, except the limits of liability, will operate in the same manner as if there were a separate policy covering each insured and Additional Insured; (g) waive any right of the insurers to any setoff, counterclaim or other deduction against the Additional Insureds but for any outstanding premiums due and owing with respect to the Aircraft; (h) provide for worldwide coverage, subject to such limitations and exclusions as may be expressly set forth in the certificates of insurance delivered pursuant to Section 11.4 provided such limitations and exclusions are not applicable to the territories where the Aircraft is operated by Sublessee, or as Sublessor may otherwise agree in writing; and (i) be denominated in Dollars.

## 11.2 Aircraft Hull Insurance.

11.2.1 On or prior to the Delivery Date and throughout the Term, Sublessee will maintain (or cause to be maintained) in full force and effect, at its expense and on terms substantially similar to and no less favorable than insurance carried by Sublessee on similar aircraft in its fleet, all-risk ground and flight aircraft hull insurance covering the Aircraft including coverage of the Engines and Parts while temporarily removed from or not installed on the Aircraft and not replaced with similar components in amounts denominated and payable in Dollars not less than, in respect of the Aircraft, the Agreed Value, and with respect to any Engines or Parts while removed from the Aircraft, on a replacement value basis. Sublessee will maintain such hull war and allied perils insurance covering any loss or damage arising from hull war and allied perils:

(a) war, invasion, acts of foreign enemies, hostilities (whether war be declared or not), civil war, rebellion, revolution, insurrection, martial law, military or usurped power or attempts at usurpation of power;

(b) strikes, riots, civil commotions or labor disturbances;

(c) any act of one or more persons, whether or not agents of a sovereign power, for political or terrorist purposes and whether the loss or damage resulting therefrom is accidental or intentional;

(d) any malicious act or act of sabotage;

(e) confiscation, nationalization, seizure, restraint, detention, appropriation, requisition for title or use by or under the order of any government (whether civil, military or de facto) or public or local authority; and

(f) hijacking or any unlawful seizure or wrongful exercise of control of the Aircraft or any Engine or any Airframe on which any Engine is installed or crew in flight (including any attempt at such seizure or control) made by any person or persons on board the Aircraft or such Airframe acting without the consent of the insured.

11.2.2 The hull war and allied perils insurances will be in accordance with Lloyd's Aviation Underwriters Association Standard Policy Form LSW 555D or equivalent unless otherwise approved by Sublessor in writing. Sublessee covenants that all policies and subsequent policies taken out in accordance with this Section 11.2 will: (a) be issued by insurance companies or underwriters of internationally recognized standing in the aviation industry; (b) be endorsed to name Sublessor or its designee as loss payee (each to the extent their interest may appear) (collectively, "Loss Payee") Head Lessor, Owner Participant, any Financing Parties, Sublessor and its designees as Additional Insureds to the extent of each of their interests in respect of hull claims that become payable on the basis of a total loss and will provide that any other loss will be settled (net of any relevant policy deductible) with such parties as may be necessary to repair the Aircraft unless otherwise agreed in writing after consultation among the insurers, Head Lessor, Sublessor and Sublessee (it being agreed that where the loss is not expected to exceed \$[\*\*\*] and, unless Sublessor has notified the insurers to the contrary, such loss will be settled with and paid to Sublessee); (c) provide that, in respect of the interest of any Loss Payees in such policies, the insurance will not be invalidated by any act or omission, except that such Loss Payee so protected has not caused, contributed to or knowingly condoned the said act or omission; (d) provide that none of the Loss Payees (other than Sublessee), will have responsibility for the payment of premiums or any other amount payable under such policies; (e) provide that insurers waive all rights of subrogation as against the Loss Payees; (f) provide that, if such insurance is canceled or allowed to lapse for any reason whatsoever, or if any material change is made in such insurance which adversely affects the interest of a Loss Payee, such cancellation, lapse or change will not be effective as to any Loss Payee for [\*\*\*] days ([\*\*\*] days for nonpayment of premiums and [\*\*\*] days, or such other period as is then customarily obtainable in the industry, in the case of any hull war and allied perils



coverage) after the giving of written notice from such insurers or Sublessee's appointed insurance broker to Sublessor; (g) waive any right of the insurers to any setoff, counterclaim or other deduction against the Loss Payees but for any outstanding premiums due and owing with respect to the Aircraft; (h) provide for worldwide coverage, subject to such limitations and exclusions as may be set forth in the certificates of insurance delivered pursuant to Section 11.4 provided such limitations and exclusions are not applicable to the territories where the Aircraft is operated (or caused to operated) by Sublessee, or as Sublessor may otherwise agree in writing; (i) contain a 50/50 claims funding clause in the form of Lloyd's standard provision AVS103 (or a replacement for such clause) in the event of a dispute as to which policy in respect of the hull insurance set forth in this Section 11.2 will pay in the event of a loss; (j) provide that if any Engine is installed on an aircraft other than the Aircraft, the agreed value of that other aircraft shall be automatically increased by the replacement value of such Engine(s) (or the Agreed Value for such Engine, if any is specified from time to time) while so installed; this shall be noted on the insurance certificate for the Aircraft; (k) confirm that the insurers are not entitled to replace the Aircraft in case of an insured Total Loss and (l) have deductibles not greater than the maximum deductible amount set forth in Appendix B.

11.2.3 All insurance coverage will, among other things:

(a) Be maintained in accordance with best industry practice for comparable operators

(b) be subject to Airline Finance/Sublease Contract Endorsement AVN67B (or equivalent coverage). Sublessee may procure endorsements to the relevant insurance or reinsurance policies required to be maintained so as to incorporate the terms of Lloyd's Form AVN67B (or equivalent coverage) into such insurance or reinsurance policies, in which event, to the extent that any provisions of such Lloyd's Form AVN67B (or any revised form) endorsement conflicts or is otherwise inconsistent with the requirements of any provision of this Agreement relating to insurance or reinsurance then (so long as it will remain general aviation insurance practice to insure aircraft financed or leased by financial institutions on the basis of such endorsement), such conflicting or inconsistent provision of this Agreement will be of no further force and effect and such endorsement will be deemed to satisfy the requirements of each such conflicting or inconsistent provision of this Agreement;

(c) operate on a worldwide basis;

(d) contain a provision entitling any Indemnitee to initiate a claim under any policy in the event of the refusal or failure of Sublessee to do so;

(e) accept and insure the indemnity provisions of the Sublease to the extent of the risks covered by the policies;

(f) be maintained through the London or New York insurance markets or in any other leading insurance markets. Insurers shall be of internationally recognized responsibility and rated A-, or better by AM Best.

11.2.4 For the purposes of this Section 11, the definition of Aircraft will not include the Aircraft Documents.

11.3 Spares Insurance. Sublessee will carry spares insurance at a level reasonably considered by Sublessor to be appropriate to Sublessee's operations.

11.4 Default. If Sublessee defaults in effecting, keeping or maintaining any insurance or if any insurance for any reason becomes void, Sublessor may (but without any obligation to do so and without prejudice to Sublessor's other rights and remedies under this Agreement) effect, keep up or maintain such insurance and, subject to the terms of the ATSA, Sublessee will promptly upon demand repay or cause to be repaid to Sublessor all premiums and other moneys from time to time paid or payable by Sublessor in respect of such insurance.

11.5 Certificates. Not less than [\*\*\*] Business Days before the Delivery Date, unless otherwise approved by Sublessor in writing, and promptly upon each renewal thereafter, Sublessee will furnish to Sublessor certificates of insurance written in English from an authorized representative of the insurers providing the insurance required under this Agreement and certificates of reinsurance from reinsurance brokers (together with a letter of undertaking from each of such representative and such reinsurance brokers stating that such insurance and reinsurance complies with the terms of this Agreement) describing in detail the insurance and reinsurance carried and maintained on the Aircraft. Such certificates of insurance will be in form and substance reasonably satisfactory to Sublessor. Failure of Sublessee to furnish certificates of insurance or procure and maintain the insurance required herein or the failure of Sublessor to request such certificates will not constitute a waiver of Sublessee's obligations under this Agreement.

11.6 Reinsurance. If the Aircraft is registered in a jurisdiction other than the United States, United Kingdom, Canada or a member state of the European Union, reinsurance may be required by Sublessor if it is customary for international aircraft lessors to require reinsurance in such jurisdictions, and such reinsurance shall:

- (i) be on the same terms as the original insurance and will include the provisions of this Section 11;
- (ii) provide that notwithstanding any bankruptcy, insolvency, liquidation, dissolution or similar proceedings of or affecting the reinsured that the reinsurers' liability will be to make such payments as would have fallen due under the relevant policy of reinsurance if the reinsured had (immediately before such bankruptcy, insolvency, liquidation, dissolution or similar proceedings) discharged its obligations in full under the original insurance policies in respect of which the then relevant policy of reinsurance has been effected; and

(iii) contain a “cut-through” clause in the following form (or otherwise satisfactory to Sublessor):

“The Reinsurers and the Reinsured hereby mutually agree that in the event of any claim arising under the reinsurances in respect of a total loss or other claim made between Sublessor and Sublessee such claim is to be paid to the person named as sole loss payee under the primary insurances, the Reinsurers will in lieu of payment to the Reinsured, its successors in interest and assigns pay to the person named as sole loss payee under the primary insurances effected by the Reinsured that portion of any loss due for which the Reinsurers would otherwise be liable to pay the Reinsured (subject to proof of loss), it being understood and agreed that any such payment by the Reinsurers will (to the extent of such payment) fully discharge and release the Reinsurers from any and all further liability in connection therewith”; subject to such provisions not contravening any Law of the state of incorporation of the Sublessee;

11.7 Premiums. Sublessee agrees to pay (or cause to be paid) the premiums (or installments of the premiums) as required by the terms of such policies.

11.8 Claims. After a Total Loss, in relation to the Aircraft, has occurred and so long as an Event of Default will not have occurred and be continuing, Sublessee may pursue any and all claims against the insurers in respect of the insurance with respect to the Aircraft, subject to consultation with Sublessor, except that no settlement or compromise of any claim with respect to such Total Loss may be made without the approval of Sublessor. Should an Event of Default have occurred and be continuing and any claim be made under any of the insurance policies, Sublessor will have full power to make, enforce, settle or compromise all claims with the insurers in respect of the insurance (other than the liability insurance) or for compensation and to sue for, recover, receive and give discharge for all moneys payable by virtue of such claim, to be held and applied in accordance with Section 11.2, provided all such power will be exercised by Sublessor reasonably and in good faith and Sublessee will be notified simultaneously of the exercise by Sublessor of any such power. Sublessee will irrevocably and unconditionally assign or cause to be assigned the insurance to Sublessor if such an assignment is advisable for the purpose of the preceding sentence. Sublessee will do or cause to be done all things reasonably necessary and provide or cause to be provided all documents, evidence and information to enable the assignee or loss payee referred to above to collect or recover any moneys due or to become due in respect of the insurance.

11.9 Application of Payments During Continuation of an Event of Default. Any amount referred to in Section 11.2 which is payable to or retainable by Sublessee will not be paid to or retained by Sublessee if, at the time of such payment or retention, an Event of Default will not have occurred and be continuing but will be held by or paid over to Sublessor as security for the obligations of Sublessee under this Agreement. Upon the earlier of: (a) such time as there will not be continuing any such Event of Default; or (b) the Return Date, such amount will be paid to Sublessee to the extent not previously applied in accordance with the terms of this Agreement.

11.10 Maintenance. Sublessee will maintain the Insurance in full force during the Term, and thereafter as expressly required in this Agreement, which shall be in accordance with best industry practice of persons operating similar aircraft in similar circumstances. The insurance required hereunder shall in any event meet the requirements set forth in this Section 11 which may be amended from time to time by Sublessor so that the scope and level of cover is maintained, and the interests of Sublessor and each Indemnitee are prudently protected in line with best industry practice.

11.11 Insurance Undertakings and Information.

Sublessee will:

11.11.1 comply with the terms and conditions of each policy of any Insurance and not do, consent or agree to any act or omission that:

- (a) invalidates or may invalidate any Insurance; or
- (b) renders or may render void or voidable the whole or any part of any insurance required under this Section 11; or
- (c) brings any particular liability within the scope of an exclusion or exception to any insurance required under this Section 11;

11.11.2 not take out without the prior written approval of Sublessor any insurance or reinsurance in respect of the Aircraft which may adversely affect the scope of the coverage required under the Sublease. The insured value for the Aircraft shall be the Agreed Value;

11.11.3 commence renewal procedures at least [\*\*\*] days prior to expiry of any insurance required under this Section 11 and provide to Sublessor:

- (a) promptly upon request from Sublessor, a report (which may be in the form of a telephone call) regarding renewal negotiations prior to each expiry date;
- (b) facsimile or e-mail confirmation of completion of renewal prior to each policy expiry date; and
- (c) on request, provide to Sublessor copies of documents or other information evidencing the Insurance, excluding any premium related information; and
- (d) provide any other insurance and reinsurance related information, or assistance, in respect of the Insurance as Sublessor may reasonably require.

## 12. Assignment.

12.1 Assignment by Sublessee. SUBLESSEE WILL NOT ASSIGN, DELEGATE OR OTHERWISE TRANSFER (VOLUNTARILY, INVOLUNTARILY, BY OPERATION OF LAW OR OTHERWISE) ANY OF ITS RIGHTS OR OBLIGATIONS UNDER THIS SUBLEASE OR CREATE OR PERMIT TO EXIST ANY SECURITY INTEREST OTHER THAN ANY PERMITTED LIEN OVER ANY OF ITS RIGHTS UNDER THIS SUBLEASE, AND ANY ATTEMPT TO DO SO SHALL BE NULL AND VOID.

### 12.2 Assignment by Sublessor.

12.2.1 Sublessor may, at its own expense and without the prior consent of Sublessee, assign or transfer all of its rights and obligations under this Agreement to an Affiliate of Sublessor or to any Person in connection with any merger, reorganization, sale of all or substantially all of its assets or any similar transaction upon providing prior written notice of such assignment to Sublessee, provided that such assignment or transfer does not increase Sublessee's costs or obligations, it being understood and agreed that any assignment or transfer by Sublessor to any of its Affiliates will not be deemed to increase Sublessee's costs or obligations. Upon: (a) any such assignment becoming effective; and (b) the assignee assuming all of Sublessor's obligations under this Agreement, Sublessor will be released of any further obligations under this Agreement.

12.2.2 After written notice from Sublessor of any assignment or transfer of all or any of Sublessor's rights and obligations under this Agreement, and at Sublessor's expense, Sublessee will, as soon as practicable, execute any agreements or other instruments that may be reasonably requested by Sublessor in order to allow, give effect to, or perfect any assignment or transfer of Sublessor's rights and obligations under this Agreement.

12.2.3 In any instance where a transfer or assignment effected by Sublessor is to more than one person, such transferees or assignees will select an agent who will act on behalf of all such transferees or assignees and with whom Sublessee may deal exclusively and notify Sublessee of such agent.

12.3 Assignment of Sublease. Sublessor may assign this Sublease, as security, to Head Lessor (or its nominee) for Sublessor's obligations under the Head Lease. Sublessee agrees to acknowledge and agree to such assignment pursuant to an agreement reasonably acceptable to Head Lessor, provided that reasonably sufficient notice is given and any costs (including but not limited to reasonable legal fees) shall be at Sublessor's cost.

### 12.4 Assignment of Warranties.

12.4.1 With effect from Delivery and for the duration of the Term, subject to any required consent of any manufacturer or cargo conversion provider, Sublessor shall make available or cause to be made available to Sublessee and authorize Sublessee or cause Sublessee to be authorized to exercise the benefit of all manufacturers' warranties in relation to the repair or remedy of any defect in the Aircraft (including compensation for loss of use of the Aircraft), any Engine or any Part and other product support for the Aircraft that has been assigned to it to the extent it is permitted to do so. In furtherance of the

foregoing, Sublessor shall take such actions, at Sublessor's cost and expense, as Sublessee may reasonably request to make such warranties available to Sublessee. Sublessee will give Sublessor prompt written notice of any warranty claim that is settled with Sublessee on the basis of a cash payment in excess of the Damage Notification Threshold.

12.4.2 If an Event of Default has occurred and is continuing, Sublessor may: immediately recover from Sublessee the proceeds of any warranty claim previously paid to Sublessee to the extent that such claims relate to any defect in the Aircraft not fully and completely rectified by Sublessee before such Event of Default occurred and Sublessor may:

(a) retain for its own account any such proceeds previously paid to Sublessor which would have been remitted to Sublessee under this Section 12 in the absence of such Event of Default; and

(b) withdraw the warranty and support benefits from Sublessee and cause any proceeds of any pending claims to be paid to Sublessor, rather than Sublessee.

12.4.3 Sublessee will take all steps as are necessary (i) to ensure that all work done on the Aircraft during the Term is covered by customary warranties which, if still in effect, would be transferable to Sublessor (or Sublessor's nominee) at the end of the Term and (ii) at the end of the Term to ensure that the benefit of any and all warranties relating to the Aircraft to which this Section 12 applies and which have not expired is vested in Sublessor.

### 13. "As-Is" Condition, Disclaimer and Release.

13.1 DISCLAIMER. EXCEPT AS SPECIFICALLY SET FORTH IN THIS AGREEMENT, FROM AND AFTER THE DELIVERY BY SUBLESSOR AND ACCEPTANCE BY SUBLESSEE, THE AIRCRAFT DELIVERED HEREUNDER IS SUBLEASED TO SUBLESSEE IN "AS IS, WHERE IS" CONDITION, AND SUBLESSEE HEREBY WAIVES, RELEASES AND RENOUNCES ANY AND ALL WARRANTIES, OBLIGATIONS AND LIABILITIES, EXPRESS OR IMPLIED, DIRECT OR INDIRECT, OF SUBLESSOR, ITS SUCCESSORS AND ASSIGNS AND ALL OTHER INDEMNITEES, AND ANY AND ALL RIGHTS, CLAIMS, AND REMEDIES, EXPRESS OR IMPLIED, DIRECT OR INDIRECT, OF SUBLESSEE AGAINST SUBLESSOR, ITS SUCCESSORS AND ASSIGNS AND ALL OTHER INDEMNITEES, ARISING BY LAW OR OTHERWISE (EXCEPT AS SET FORTH IN THIS AGREEMENT) WITH RESPECT TO THE AIRCRAFT OR ANY PARTS OR THE USE OR OPERATION OF THE AIRCRAFT OR ANY PARTS OR ANY NONCONFORMANCE OR DEFECT THEREIN, INCLUDING: (a) ANY WARRANTY AS TO THE CONDITION OF THE AIRCRAFT; (b) ANY IMPLIED WARRANTY OF MERCHANTABILITY OR FITNESS FOR ANY PARTICULAR PURPOSE; (c) ANY IMPLIED WARRANTY ARISING FROM COURSE OF PERFORMANCE, COURSE OF DEALING OR USAGE OF TRADE; (d) ANY LIABILITY, RIGHT, CLAIM OR REMEDY IN TORT, WHETHER OR NOT ARISING FROM THE STRICT LIABILITY OR THE ACTUAL OR IMPUTED NEGLIGENCE OF SUBLESSOR AND ITS RESPECTIVE SUCCESSORS OR ASSIGNS OR ANY OTHER INDEMNITEE; AND (e) ANY STATUTORY OR OTHER WARRANTY, CONDITION, DESCRIPTION OR REPRESENTATION, EXPRESS OR IMPLIED, AS TO THE STATE, QUALITY, VALUE, CONDITION, DESIGN, OPERATION OR FITNESS OF THE AIRCRAFT.

13.2 ACKNOWLEDGEMENT. SUBLESSEE AGREES AND ACKNOWLEDGES THAT:

13.2.1 NO INDEMNITEE WILL HAVE ANY LIABILITY IN RELATION TO, AND NO INDEMNITEE HAS NOR SHALL IT BE DEEMED TO HAVE ACCEPTED, MADE OR GIVEN (WHETHER BY VIRTUE OF HAVING DONE OR FAILED TO DO ANY ACT, OR HAVING ACQUIRED OR FAILED TO ACQUIRE ANY STATUS UNDER OR IN RELATION TO THE SUBLEASE OR OTHERWISE), ANY GUARANTEES, COVENANTS, WARRANTIES OR REPRESENTATIONS, EXPRESS OR IMPLIED, WITH RESPECT TO, THE AIRCRAFT OR ANY ENGINE OR PART OR ANY SERVICES PROVIDED BY SUBLESSOR OR ANY OTHER INDEMNITEE UNDER THE SUBLEASE OR ANY OTHER OPERATIVE DOCUMENT, INCLUDING THE TITLE, DESCRIPTION, AIRWORTHINESS, COMPLIANCE WITH SPECIFICATIONS, OPERATION, MERCHANTABILITY, QUALITY, FREEDOM FROM INFRINGEMENT OF PATENT, COPYRIGHT, TRADEMARK OR OTHER PROPRIETARY RIGHTS, FITNESS FOR ANY PARTICULAR USE OR PURPOSE, VALUE, DURABILITY, DATE PROCESSING, CONDITION, OR DESIGN, OR AS TO THE QUALITY OF THE MATERIAL OR WORKMANSHIP, THE ABSENCE OF LATENT OR OTHER DEFECTS, WHETHER OR NOT DISCOVERABLE, OR AS TO ANY OTHER MATTER WHATSOEVER, EXPRESS OR IMPLIED (INCLUDING ANY IMPLIED WARRANTY ARISING FROM A COURSE OF PERFORMANCE OR DEALING OR USAGE OF TRADE) WITH RESPECT TO THE AIRCRAFT, ANY ENGINE OR ANY PART OR ANY SERVICES PROVIDED BY SUBLESSOR OR ANY OTHER INDEMNITEE UNDER THE SUBLEASE OR ANY OTHER OPERATIVE DOCUMENT; AND

13.2.2 NO INDEMNITEE SHALL HAVE ANY OBLIGATION OR LIABILITY WHATSOEVER TO SUBLESSEE (WHETHER ARISING IN CONTRACT OR IN TORT, AND WHETHER ARISING BY REFERENCE TO NEGLIGENCE, MISREPRESENTATION OR STRICT LIABILITY OR OTHERWISE) FOR:

(a) ANY LIABILITY, LOSS OR DAMAGE CAUSED OR ALLEGED TO BE CAUSED DIRECTLY OR INDIRECTLY BY THE AIRCRAFT OR ANY ENGINE OR BY ANY INADEQUACY THEREOF OR DEFICIENCY OR DEFECT THEREIN OR BY ANY OTHER CIRCUMSTANCE IN CONNECTION THEREWITH (EXCEPT FOR DIRECT DAMAGES DUE TO SUBLESSOR'S BREACH AS AND TO THE EXTENT EXPRESSLY PROVIDED IN SECTION 4.4 OR 7.1 HEREOF);

(b) THE USE, OPERATION OR PERFORMANCE OF THE AIRCRAFT OR ANY RISKS RELATING THERETO;

(c) ANY INTERRUPTION OF SERVICE, LOSS OF BUSINESS OR ANTICIPATED PROFITS OR ANY OTHER DIRECT (EXCEPT FOR DIRECT DAMAGES DUE TO SUCH INDEMNITEE'S BREACH AS AND TO THE EXTENT EXPRESSLY PROVIDED IN SECTION 15.2.3 HEREOF AND SUBJECT TO SECTION 20.6 BELOW), INDIRECT, SPECIAL INCIDENTAL OR CONSEQUENTIAL LOSS OR DAMAGE; OR

(d) THE DELIVERY, OPERATION, SERVICING, MAINTENANCE, REPAIR, IMPROVEMENT OR REPLACEMENT OF THE AIRCRAFT, ANY ENGINE OR ANY PART.

13.3 Waiver. SUBLESSEE HEREBY WAIVES, AS BETWEEN ITSELF AND EACH INDEMNITEE, ALL ITS RIGHTS IN RESPECT OF ANY CONDITION, WARRANTY OR REPRESENTATION, EXPRESS OR IMPLIED, ON THE PART OF ANY INDEMNITEE AND ALL CLAIMS AGAINST ANY INDEMNITEE HOWSOEVER AND WHENEVER ARISING AT ANY TIME IN RESPECT OF OR OUT OF ANY OF THE MATTERS REFERRED TO IN SECTION 13.2.

#### 14. Representations and Warranties.

14.1 Sublessee's Representations and Warranties. Sublessee represents and warrants as follows, as of the Effective Date and as of the Delivery Date.

14.1.1 Legal Form and Qualification. Sublessee is a corporation organized and existing in good standing under the Laws of Minnesota and has full power to conduct its operations as presently conducted.

14.1.2 Authority. Sublessee has full power, authority and legal right to enter into, deliver and perform this Agreement and all agreements or instruments required under this Agreement.

14.1.3 Certificated Air Carrier. Sublessee is a Certificated Air Carrier.

14.1.4 Binding Obligations. This Agreement constitutes and any related documents, when entered into, will constitute, legal, valid and binding obligations of Sublessee enforceable against Sublessee in accordance with the terms of the Agreement or related documents, except as may be limited by bankruptcy, insolvency, reorganization, moratorium, or similar Laws affecting enforcement of creditors' rights generally as well as by general principles of equity.

14.1.5 No Additional Consents or Approvals. Neither the execution and delivery by Sublessee of this Agreement or any other document delivered by it in connection herewith nor the consummation of any of the transactions contemplated thereby requires the consent or approval of, the giving of notice to, or the registration with, any Governmental Entity except such consent, approval, notice or registration that will be obtained on or before the Delivery Date and such consents, approvals, notices, or registrations that may be required in the ordinary course of leasing, operating and/or maintaining the Aircraft.



14.1.6 No Violation. Neither the execution and delivery nor the performance by Sublessee of this Agreement and any other document delivered by Sublessee in connection herewith, nor consummation of any of the transactions as contemplated thereby, will result in any violation of, or be in conflict with, or constitute a default under, or result in the creation of any Lien upon any property of Sublessee under any of the provisions of Sublessee's charter or by-laws, or of any indenture, mortgage, chattel mortgage, deed of trust, conditional sales contract, lease, note or bond purchase agreement, license, bank loan, credit agreement, or other agreement to which Sublessee is a party or by which Sublessee is bound, or any Law, judgment, governmental rule, Regulation or order of any Governmental Entity.

14.1.7 No Default. No Event of Default (as defined in this Agreement and the relevant Other Sublease Agreement) will have occurred and be continuing under this Agreement (or under any of the Other Sublease Agreements) or would occur as a result of Delivery.

14.1.8 Withholding Tax. Neither the payment of Basic Rent nor the payment of any other amount required under this Agreement is subject to deduction or withholding taxes or the equivalent under the Laws of any Governmental Entity.

14.1.9 Pari Passu Ranking. The obligations of Sublessee to make payments under this Agreement will rank at least *pari passu* in right of payment with all other unsecured, unsubordinated obligations of Sublessee.

14.1.10 Location. Sublessee's location (within the meaning of Article 9-307 of the UCC) is Minnesota; and the records of the Sublessee concerning the Aircraft are maintained at such location or at the Habitual Base of the Aircraft.

14.1.11 Section 1110. Sublessor will be entitled to the benefits of Section 1110 of Title 11 of the United States Code (the "Bankruptcy Code") with respect to this Sublease in the event of any filing by Sublessee under chapter 11 of the Bankruptcy Code.

14.1.12 Financial Information. Sublessee's audited financial statements for the financial year ending December 31, 2018 have been delivered to Sublessor and:

- (i) have been prepared in accordance with GAAP; and
- (ii) are true and correct and present fairly the financial condition and results of operations of Sublessee as at the date thereof and for the period then ending and since that date there has been no material change in Sublessee's ability to carry out its obligations or its financial condition or the financial condition of its Affiliates.

14.1.13 Full Disclosure. Neither the audited financial statements referred to in Section 14.1.12 nor any other financial, operational or credit related information provided to Sublessor by Sublessee for the purposes of this Sublease contains as of the date thereof any untrue statement of a material fact or omits to state any material fact necessary in order to make the statements therein not misleading in the light of the circumstances under which they were made.

14.1.14 ERISA. Sublessee is not engaged in any transaction in connection with which it could be subjected to either a civil penalty assessed pursuant to Section 502 of ERISA or any tax imposed by Section 4975 of the Internal Revenue Code; no material liability to the Pension Benefit Guaranty Corporation has been or is expected by Sublessee to be incurred with respect to any employee pension benefit plan (as defined in Section 3 of ERISA) maintained by Sublessee or by any trade or business (whether or not incorporated) which together with Sublessee would be treated as a single employer under Section 4001 of ERISA and Section 414 of the Internal Revenue Code; there has been no reportable event (as defined in Section 4043(b) of ERISA) with respect to any such employee pension benefit plan; no notice of intent to terminate any such employee pension benefit plan has been filed or is expected to be filed, nor has any such employee pension benefit been terminated; no circumstance exists or is anticipated that constitutes or would constitute grounds under Section 4042 of ERISA for the Pension Benefit Guaranty Corporation to institute proceedings to terminate, or to appoint a trustee to manage the administration of, such an employee pension benefit plan; and no accumulated funding deficiency (as defined in Section 302 of ERISA or Section 412 of the Internal Revenue Code), whether or not waived, exists with respect to any such employee pension benefit plan.

14.1.15 Material Adverse Change. There has been no material adverse change in the financial condition or operations of Sublessee which would have an adverse effect on the ability of Sublessee to comply with its obligations under this Sublease since the date of this Sublease.

14.1.16 Taxes. Sublessee has delivered all necessary returns and payments due (other than payments that are being diligently contested in good faith by appropriate proceedings) to the tax authorities in its state of incorporation, the state of registry of the Aircraft and the Habitual Base of the Aircraft and is not required by Law to deduct any Taxes from any payments under the Sublease.

14.2 Sublessor's Representations and Warranties. Sublessor represents and warrants as follows, as of the Effective Date and of the Delivery Date.

14.2.1 Organization. Sublessor is a limited liability company organized and existing in good standing under the Laws of Delaware, and has all requisite power, authority and legal right to enter into and perform its obligation under this Agreement and any other document delivered by Sublessor in connection herewith.

14.2.2 Authorization. Sublessor has duly authorized, executed and delivered this Agreement and, assuming this Agreement has been duly authorized, executed and delivered by Sublessee, this Agreement constitutes a legal, valid and binding obligation of Sublessor enforceable against Sublessor in accordance with its terms, except as may be limited by bankruptcy, insolvency, reorganization, moratorium, or similar Laws affecting enforcement of creditors' rights generally as well as by general principles of equity.

14.2.3 No Violation. Neither the execution and delivery or performance by Sublessor of this Agreement and any other document delivered by Sublessor in connection herewith, nor consummation of any of the transactions as contemplated thereby, will result in any violation of, or be in conflict with, or constitute a default under, or result in the creation of any Lien upon any property of Sublessor under any indenture, mortgage, chattel mortgage, deed of trust, conditional sales contract, lease, note or bond purchase agreement, license, bank loan, credit agreement, or other agreement to which Sublessor is a party or by which Sublessor is bound, or any Law, judgment, governmental rule, Regulation, or order of any Governmental Entity.

14.2.4 No Consents or Approvals. Neither the execution and delivery by Sublessor of this Agreement or any other document delivered by it in connection herewith nor the consummation of any of the transactions contemplated thereby requires the consent or approval of, the giving of notice to, or the registration with, any Governmental Entity.

14.2.5 Ownership. As of the Delivery, Head Lessor holds legal title to the Aircraft.

## 15. Covenants.

15.1 Sublessee's Covenants. Sublessee hereby covenants with Sublessor that during the Term, Sublessee will fully comply with and perform the following obligations.

15.1.1 Sublessee will preserve its existence and maintain all rights, privileges, licenses, and franchises necessary to its business or material to its performance of its obligations under this Agreement.

15.1.2 Sublessee will promptly, upon becoming aware of the same, notify Sublessor in writing of the occurrence of any Event of Default enumerated in Section 16.1.1(c).

15.1.3 [Reserved]

15.1.4 Sublessee will not do or knowingly permit to be done or omit or knowingly permit to be omitted any act or thing which might reasonably be expected to jeopardize the rights of Sublessor as an Additional Insured or loss payee under the insurance required under Section 11, it being understood and agreed by Sublessor that any such act or omission by Sublessor, an Affiliate of Sublessor or their representatives will not be deemed an act or omission of Sublessee.

15.1.5 Sublessee will not claim any interest in the Aircraft other than as Sublessee under this Agreement.

15.1.6 Sublessee will not at any time: (a) represent or, except to the extent of the external livery of the Aircraft, hold out Owner Participant, Head Lessor, Sublessor or any Financing Party as carrying goods or passengers on the Aircraft or, except in accordance with applicable Laws, as being in any way connected or associated with any business activities and/or operation or carriage (whether for hire or reward or gratuitously) which may be undertaken by Sublessee; or (b) pledge the credit of Sublessor.

15.1.7 Sublessee will not attempt, or hold itself out as owning, including for Tax treatment or other purposes, or having any power, to sell, lease or otherwise dispose of the Aircraft, except as provided in Section 6.

15.1.8 Sublessee will, at its cost and expense, perform and comply with all of its agreements, undertakings and covenants in this Agreement at all times during the Term, and will take such steps as are reasonably necessary to ensure that no person acts in a manner inconsistent with such agreements, undertakings and covenants.

15.1.9 Information. Sublessee will:

(a) promptly notify Sublessor of any Total Loss or of any event which is likely to result in an insurance claim in excess of the Damage Notification Threshold and upon Sublessor's request, status updates relating to such claim;

(b) promptly after Sublessee has knowledge thereof, notify Sublessor of the occurrence of any Default or Event of Default;

(c) within [\*\*\*] Business Days after receipt by Sublessee of a request by Sublessor (or such shorter period as may be set forth in any written request by any Governmental Entity for information or documents), Sublessee shall furnish in writing to Sublessor such information or documents within its possession or which are reasonably available to it (or copies thereof certified as correct by an authorized officer of Sublessee) regarding the Aircraft as may reasonably be requested by Sublessor or as may be required to enable Head Lessor, Sublessor or Owner Participant to file any report or document required to be filed by it with any Governmental Entity because of Head Lessor's ownership interest in the Aircraft, the Airframe or the Engines;

(d) promptly after receipt thereof, provide Sublessor with a copy of any letter, notice, claim or threat of suit, that relates to the Aircraft, the Sublease and/or is related to any matter which is reasonably likely to result in the Aircraft (or any part of it) being detained, seized and/or sold; and

(e) promptly after Sublessor's request, provide Sublessor with such information as is reasonably required so that Head Lessor, Sublessor, Owner Participant or any Financing Party is able to comply with "know your customer" identification procedures, checks and requirements ("KYC").

15.1.10 General. Sublessee will:

(a) maintain its business (as an airline, if applicable on the Delivery Date), preserve its corporate existence and maintain all rights, privileges, licenses and franchises material thereto or material to performing its obligations under the Sublease;

(b) ensure that the Habitual Base remains the habitual base of the Aircraft;

(c) not operate, maintain, insure or deal with, or keep records with respect to, the Aircraft in a manner which discriminates against the Aircraft adversely insofar as Sublessor's, Head Lessor's, Owner Participant's or Financing Parties' interests are concerned, when compared with the manner in which Sublessee operates, maintains, insures or deals with, or keep records with respect to, similar aircraft, engines or parts in Sublessee's fleet;

(d) provide Sublessor with notice of any change of (i) its jurisdiction of organization or (ii) its location (as defined in Section 9-307 of the UCC) as set forth in this Agreement, within [\*\*\*] Business Days of such change;

(e) not liquidate or dissolve;

(f) comply with all applicable Environmental Laws that are applicable to the Aircraft, the Sublessee and the person operating or possessing the Aircraft;

(g) for so long as and to the extent required under Section 1110 of Title 11 of the United States Code in order that Sublessor continue to be entitled to the benefit of such Section 1110 with respect to the Aircraft, remain a Certificated Air Carrier;

(h) remain a Citizen of the United States

15.1.11 Protection. Sublessee will:

(a) take all actions reasonably requested by Sublessor (at Sublessor's cost, except as otherwise provided herein) that are within Sublessee's control to keep the Aircraft registered with the FAA in the name of Head Lessor and subject to a first priority Lien (subject to Permitted Liens) in favor of any Financing Party and, where applicable, comply with the Geneva Convention;

(b) record on each relevant register that Head Lessor is the owner of the Aircraft and, if such facilities exist (i) file the Sublease and the Head Lease (or respective particulars thereof) with the Aviation Authority, (ii) at Sublessor's cost file the Financing Documents or notices as to the interests of the Financing Parties (if any);

(c) make any and all filings reasonably requested by Sublessor (or its designee), any Financing Party, Head Lessor or Owner Participant to be made with the registry of the Aviation Authority that are within its control and take all other actions within its control that are necessary or advisable by the local counsel to reflect on the FAA registry any change in the ownership of the Aircraft, or in the interests of Sublessor, any Financing Party, Head Lessor or Owner Participant in this Agreement, the Head Lease or the Aircraft, any modification to the Aircraft (such as the permanent replacement of any Engine or Part in accordance with the Sublease) or as a result of any change in applicable Regulation. Sublessor will bear any costs incurred as a consequence of Sublessor's obligation to any Financing Party or a transfer in accordance with Section 12.2 and any other costs incurred in complying with this Section 15.1.11(c), including in connection with the replacement of any Engine;

(d) from time to time, at the request of the Sublessor, to take any actions which the Sublessor reasonably determines should be taken to ensure that the Cape Town Convention is (and continues to be) applicable to the Sublease and that the interests of the Sublessor, Head Lessor and/or any Financing Party in relation to each Airframe and Engine are effectively registered at the International Registry. This would include, in particular, promptly consenting to and co-operating with the Sublessor, Head Lessor, Owner Participant and/or any Financing Party, so that as soon as practicable from time to time registrations are made to permit the interests of the Sublessor, Head Lessor and/or any Financing Party in connection with each Airframe and Engine and any associated rights to be perfected and registered as International Interests under the Cape Town Convention and to remove or discharge interests where the Sublessor so requires;

(e) execute and deliver such other instruments and documents as Sublessor reasonably requests to protect the interest of Sublessor, Head Lessor or the Financing Parties.

15.1.12 Charges. Sublessee will pay all navigation charges, air traffic control charges, landing charges or other amounts of any nature imposed by any Government Entity with respect to Sublessee, the Aircraft and/or the Sublease except to the extent that, in the reasonable opinion of Sublessor, such payment is being contested in good faith by appropriate proceedings in respect of which adequate reserves have been provided by Sublessee and non-payment of which does not give rise to any material likelihood of the Aircraft or any interest therein being sold, forfeited or otherwise lost or of criminal liability on the part of Head Lessor, Sublessor or Owner Participant.

15.2 Sublessor's Covenants. Sublessor hereby covenants with Sublessee that during the Term, Sublessor will fully comply with and perform the following obligations.

15.2.1 Sublessor will preserve its existence and maintain all rights, privileges, licenses, and franchises necessary to its business or material to its performance of its obligations under this Agreement.

15.2.2 Sublessor will not do or knowingly permit to be done or omit or knowingly permit to be omitted any act or thing which might reasonably be expected to jeopardize the rights of Sublessee as an insured or loss payee under the insurance required under Section 11, it being understood and agreed by Sublessee that any such act or omission by Sublessee, an Affiliate of Sublessee or their representatives will not be deemed an act or omission of Sublessor.

15.2.3 Sublessor's Covenant of Quiet Enjoyment. Subject to Section 6.10, Sublessor hereby covenants with Sublessee that, during the Term (not including any Extended Term), so long as an Event of Default will not have occurred and be continuing, neither Sublessor, Head Lessor, Owner Participant or any Financing Party or any Person

acting on such Person's behalf or in such Person's stead, any predecessor or successor in interest of Sublessor, Head Lessor, Owner Participant or any Financing Party nor any person claiming an interest in the Aircraft by or through Sublessor, Head Lessor, Owner Participant or any Financing Party, will interfere with Sublessee's rights under this Agreement or Sublessee's quiet and undisturbed use and enjoyment of the Aircraft; except that this Section 15.2.3 will not limit Sublessor's right of inspection as set forth in this Agreement. Should such an interference occur, Sublessor will promptly, with respect to itself, and will promptly use commercially reasonable efforts with respect to such other Persons to, eliminate the cause of such interference upon becoming aware of same in any manner, including by receipt of notice from Sublessee.

## 16. Default; Remedies.

### 16.1 Events of Default.

16.1.1 An "Event of Default" means the occurrence and continuance of any of the following events (and such events shall constitute a "default" under the Cape Town Convention):

(a) Sublessee fails to make any payment of Basic Rent within [\*\*\*] Business Days of the relevant due date at the place and in the funds required under this Agreement.

(b) Sublessee fails to make any other payment due within [\*\*\*] days of the later of the relevant due date or Sublessor's written demand at the place and in the funds required under this Agreement.

(c) Sublessee fails to carry and maintain insurance on or in respect of the Aircraft (or to cause such insurance to fail to be carried or maintained) in accordance with Section 11 or operates (or allows the operation of) the Aircraft without such insurance coverage being in full force and effect with regard to such operation.

(d) Any representation or warranty made by Sublessee herein was incorrect in any material respect at the time made or deemed to be made.

(e) Any event of default or termination event, howsoever described, occurs under any Other Sublease Agreement.

(f) Sublessee fails to return possession of the Aircraft and the Aircraft Documents to Sublessor at the Return Location upon the Expiration.

(g) Sublessee fails to perform or observe any other covenant, condition or agreement to be performed or observed by it, and such failure continues unremedied for a period of [\*\*\*] days after written notice by Sublessor, except that such failure will not constitute an Event of Default if: (i) such failure is not capable of being cured within the [\*\*\*]-day period following such notice from Sublessor; and (ii) a cure is diligently pursued by Sublessee thereafter, except that in any event such failure will constitute an Event of Default if it continues for more than [\*\*\*] days following such notice from Sublessor.

(h) Sublessee fails to satisfy any of the conditions precedent under Section 2.1 (and expressly excluding a failure of Sublessor or the Aircraft to conform to the requirements of Section 2.2) and, as a direct result of such failure, the Aircraft will not have been delivered to and accepted by Sublessee within [\*\*\*] days after the Anticipated Delivery Month.

(i) (i) Sublessee commences a voluntary case under Title 11 of the United States Code or the corresponding provisions of any successor Laws; (ii) anyone commences an involuntary case against Sublessee under Title 11 of the United States Code or the corresponding provisions of any successor Laws and either (1) the case is not dismissed by midnight at the end of the [\*\*\*] day after commencement or (2) the court before which the case is pending issues an order for relief or similar order approving the case; (iii) a court of competent jurisdiction appoints, or Sublessee makes an assignment of all or substantially all of its assets to, a custodian (as that term is defined in Title 11 of the United States Code or the corresponding provisions of any successor Laws) for its company or all or substantially all of its assets; or (iv) Sublessee fails generally to pay its debts as they become due (unless those debts are subject to a good-faith dispute as to liability or amount) or acknowledges in writing that it is unable to do so.

(j) Sublessee creates or suffers to exist any Lien for taxes of any kind or arising out of a judgment or award against Sublessee which Lien does not constitute a Permitted Lien and is not being contested by Sublessee in good faith by appropriate procedures.

16.2 Remedies. If an Event of Default occurs, Sublessor may at its option (and without prejudice to any of its other rights and remedies under the Sublease, at law, in equity and/or otherwise), at any time thereafter while such Event of Default is continuing (without notice to Sublessee except as required under applicable Law) and subject to compliance with non-waivable mandatory requirements of applicable Law:

16.2.1 accept such repudiation and by notice to Sublessee and with immediate effect cancel and/or terminate the leasing of the Aircraft and/or the Sublease whereupon all rights of Sublessee under the Sublease shall cease (but without prejudice to the continuing obligations of Sublessee that survive under the Sublease, including, obligations to provide Insurance, maintain and repair the Aircraft and/or redeliver the Aircraft in conformity with the Return Condition Requirements); and/or

16.2.2 proceed by appropriate court action or actions to enforce performance of the Sublease or to recover damages, including consequential damages, sustained by Sublessor by reason of Sublessee's breach of the Sublease, and all other amounts payable by Sublessee to Sublessor or to any Indemnitee pursuant to the terms of the Sublease; and/or



16.2.3 to the extent permitted by applicable Law, take possession of and/or seize the Aircraft, for which purpose and to the extent permitted by applicable Law, Sublessor (or its nominee) may enter any premises belonging to or in the occupation of or under the control of Sublessee where the Aircraft may be located; and/or

16.2.4 by serving notice, require Sublessee to ground the Aircraft and/or redeliver the Aircraft in conformity with the Return Condition Requirements at the time and on the date designated by Sublessor in its sole and absolute discretion and at the Return Location (or such other location as Sublessor may require), provided that if the Aircraft is not redelivered in conformity with the Return Condition Requirements, Sublessee shall reimburse Sublessor for all costs and expenses incurred to conform the Aircraft with the Return Condition Requirements; and/or

16.2.5 require that Sublessee pay to Sublessor, and Sublessee shall be liable for and immediately pay to Sublessor, and/or proceed by appropriate court action or actions to recover any or all of the following amounts, but in any case, without duplication:

(a) all Basic Rent and other amounts which are or become due and payable under the Sublease prior to the earlier to occur of the date Head Lessor sells or Sublessor re-leases the Aircraft or receives payment of the amount calculated pursuant to clause (ii) below;

(b) an amount equal to Sublessor's reasonably anticipated Enforcement and Remarketing Costs and Aircraft Condition Damages;

(c) all amounts indemnified by Sublessee pursuant to Section 16.3;

(d) such additional amount, if any, as may be necessary to place Sublessor in the same economic position as Sublessor would have been in if Sublessee had timely performed each of its obligations under the Sublease; and

(e) all reasonable attorney's fees, costs and expenses incurred to enforce the Sublease or Sublessor's rights and/or remedies or as a result of Sublessee's default under the Sublease or failure to comply with the obligations under the Sublease.

It being understood that, to the extent that any of the foregoing amounts represents an estimate by Sublessor of losses, damages, costs or expenses which Sublessor expects to incur, (x) Sublessor shall adjust the amount thereof as needed to reflect the actual amount of such losses, damages, costs or expenses incurred by Sublessor when substantially all of such amounts become known to Sublessor, but Sublessee shall nevertheless be obligated to pay the amount demanded by Sublessor (subject to such subsequent adjustment), and (y) notwithstanding the amount specified in such demand, Sublessor shall be entitled to claim such other (and greater or additional) amount in any action against Sublessee under the Sublease, subsequent demand and/or any other damages that Sublessor may sustain; and/or require Sublessee to pay, and Sublessee shall pay to Sublessor, interest on all unpaid amounts at a rate of the lesser of [\*\*\*]% and the maximum amount permitted by Law, from the due date until the date of payment in full.

No remedy referred to in this Section 16.2, is intended to be exclusive, but, to the extent permissible under the Sublease or under applicable Law, each shall be cumulative and in addition to any other remedy referred to above or otherwise available to Sublessor at Law or in equity and in Sublessor's sole and absolute discretion; and the exercise by Sublessor of any one or more of such remedies shall not preclude the simultaneous or later exercise by Sublessor of any or all of such other remedies. No waiver by Sublessor of any Default or Event of Default shall in any way be, or be construed to be, a waiver of any future or subsequent Default or Event of Default.

### 16.3 Costs and Expenses; Default Indemnity.

16.3.1 Sublessee agrees to pay to Sublessor, upon demand, all reasonable and documented costs, expenses and disbursements (including reasonable attorney's fees, legal fees and expenses) incurred by Sublessor in exercising its rights or remedies under this Agreement following an Event of Default.

16.3.2 Sublessee will indemnify Sublessor on demand against any Loss which Sublessor may sustain or incur directly or indirectly as a result of any Event of Default, including, the non-delivery of the Aircraft by reason of failure of Sublessee to satisfy any conditions to that delivery. Sublessor will use reasonable endeavors to mitigate such Losses, but (i) Sublessor shall not be obliged to consult with Sublessee concerning any proposed course of action or to notify Sublessee of the taking of any particular action, and (ii) this provision is without prejudice to Head Lessor's, Owner Participant's or Sublessor's rights to cause the sale of the Aircraft, provided that Sublessee's indemnity obligations hereunder shall be without duplication of the amounts recovered by Sublessor pursuant to Section 16.1.1(j) or Section 10.

16.4 International Interests. If an Event of Default occurs and is continuing, Sublessee will, subject to its rights under applicable Law, at the request of Sublessor take all steps necessary to enable the Aircraft to be redelivered to Sublessor in accordance with the Sublease, including but not limited to discharge of any applicable International Interests relating to the Sublease, where applicable, registered on the International Registry, if action by Sublessee is required for such discharge.

16.5 Waiver of Defenses to Repossession. Neither Sublessee, nor anyone claiming through or under it, shall set up, claim, invoke or seek to take advantage of any applicable Law now or hereafter in force in any jurisdiction in which the Aircraft may be situated in order to prevent, hinder or delay any effort on the part of Sublessor to regain possession of the Aircraft, or re-export the Aircraft from any jurisdiction in which the Aircraft may be situated upon the occurrence of an Event of Default under Section 16.1 or the comparable clause under any Other Sublease Agreement and/or the Expiration Date and both prior and subsequent to entry of a final award or judgment, and Sublessee, for itself and all who may at any time claim through or under it, hereby waives, to the full extent that it may be lawful so to do, the benefit of all such applicable Law (including any rights it may have, if any, to avail itself of the protection provided by the Convention of 1933 on the Unification of Certain Rules Relating to the Precautionary Arrest of Aircraft, or any other similar law, treaty or convention applicable to Sublessee or the Aircraft

which would limit the ability of Sublessor to repossess or otherwise recover the Aircraft upon the occurrence and continuance of an Event of Default and/or the expiration or termination of the Sublease and prior and subsequent to entry of a final award or judgment). Sublessee and anyone claiming through or under it, hereby consents to an order or judgment compelling redelivery or permitting Sublessor to take possession of the Aircraft upon the occurrence of an Event of Default and/or the expiration or termination of the Sublease, and whether prior or subsequent to the entry of a final judgment, in any action or proceeding.

16.6 Power of Attorney. Sublessee hereby appoints Sublessor as the attorney-in-fact of Sublessee, with full authority in the place and stead of Sublessee and in the name of Sublessee or otherwise, for the purpose of carrying out the provisions of the Sublease and taking any action and executing any instrument that Sublessor may deem necessary or advisable to accomplish the purposes of the Sublease; provided, however, that Sublessor may only take action or execute instruments under this Article 16 after an Event of Default has occurred and is continuing. Sublessee hereby declares that the foregoing powers are granted for valuable consideration, constitute powers granted as security for the performance of the obligations of Sublessee under the Sublease and are coupled with an interest and shall be irrevocable. Without limiting the generality of the foregoing or any other rights of Sublessor under the Sublease, upon the occurrence and during the continuation of an Event of Default, Sublessor shall have the sole and exclusive right and power to (i) settle, compromise, compound, adjust or defend any actions, suits or proceedings relating to or pertaining to the Aircraft, Airframe or any Engine, or the Sublease, (ii) make proof of loss, appear in and prosecute any action arising from any policy or policies of insurance maintained pursuant to the Sublease, and settle, adjust or compromise any claims for loss, damage or destruction under, or take any other action in respect of, any such policy or policies and (iii) take any actions, including to execute and deliver any documentation, to make any filing with the Aviation Authority or to discharge any applicable International Interest, for and on behalf of the Sublessee, in connection with the matters provided for in Section 16.4.

16.7 Administration Order. If an administrator appointed in respect of Sublessee obtains an order of the court (the “order”) pursuant to any insolvency Law authorizing the sale or other disposal of the Aircraft, then in addition to (and without prejudice to Sublessee’s obligation to pay) other amounts under the Sublease, Sublessee will, immediately upon such order being made, to the extent permitted by applicable Law, pay to Sublessor or its designee the net proceeds of sale of the Aircraft, together with such additional amounts as may be required to pay to Sublessor or its designee an amount equal to the Agreed Value of the Aircraft, plus any sum which the court determines may be required to make good the deficiency referred to in such insolvency Law.

## **17. Return of Aircraft.**

17.1 Return, Place and Time of Return. Sublessee will return (or cause to be returned) the Aircraft by delivering the same to Sublessor at the Return Location on the Expiration Date or promptly upon the earlier Termination Date, except where Termination occurs pursuant to Section 19 as a result of a Total Loss.

17.2 Aircraft Return Condition Requirements. The Aircraft upon the Return to Sublessor will satisfy all of the return condition requirements described in Section 18 and Appendix H (the "Return Condition Requirements"), subject to Sublessor's obligations to bear the cost of certain maintenance events pursuant to the ATSA.

17.3 Return Receipt. Promptly upon the Return of the Aircraft in compliance with the Return Condition Requirements, Sublessor and Sublessee will execute a Return Receipt. Sublessee and Sublessor will additionally execute such additional documents as the other Party may reasonably require to evidence the termination of this Agreement.

17.4 Specific Performance. Timely Return upon the Expiration at the Return Location is of the essence of this Agreement and if the Aircraft is not returned upon the Expiration at the Return Location (other than as a result of a force majeure, requisition as provided in Section 6.9, or an act or omission by Sublessor or an Affiliate of Sublessor), Sublessor may obtain a court order requiring Sublessee to immediately return the Aircraft at the Return Location.

#### 17.5 Sublessee's Obligations Continue.

17.5.1 In the event the Return is not effected at the time and location specified herein, then the obligations of Sublessee under this Agreement will continue until the Aircraft is actually returned to Sublessor. In particular (except to the extent that a delay in the Return is attributable to acts or a failure to act on the part of Sublessor or an Affiliate of Sublessor), until Sublessee has complied with the Return Condition Requirements, Sublessee will continue to pay Basic Rent to Sublessor, will continue to insure the Aircraft pursuant to Section 11 and will be responsible for all storage fees for the Aircraft (with such storage being effected pursuant to all requirements of the Maintenance Program).

17.5.2 Neither the continued performance by Sublessee of any of its obligations after the end of the Term nor the acceptance by Sublessor of payments of Basic Rent or otherwise made by Sublessee will be considered a renewal or novation of the terms of this Agreement or a waiver of any right of Sublessor, and Sublessee will not be entitled to the quiet enjoyment of the Aircraft or any part thereof.

### 18. Return Condition Requirements.

18.1 Return. Sublessee acknowledges that the Aircraft is likely to be leased or sold to another Person at the end of the Term and as time and condition are likely to be important terms of such lease or sale, Sublessor needs the Aircraft redelivered on time and in the agreed condition. On the Expiration Date or redelivery of the Aircraft or cancellation or termination of the leasing of the Aircraft under the Sublease, Sublessee will, unless a Total Loss has occurred, redeliver the Aircraft and the Aircraft Documents at Sublessor's expense to Sublessor at the Return Location, in accordance with the procedures and in compliance with the conditions set forth in Appendix H, free and clear of all Liens (other than Sublessor's Liens), in a condition suitable for immediate operation under FAR Part 121 or as otherwise agreed by Sublessor and Sublessee and, in any case, qualifying for and having a valid and fully effective certificate of airworthiness issued by the Aviation Authority. If requested by Sublessor, Sublessee shall use commercially reasonable efforts to assist Sublessor in deregistration of the Aircraft by the Aviation Authority.

18.2 Non-Compliance. If at the time of Final Inspection, Sublessee has not fully complied with any of its obligations under the Sublease (including Appendix H), or Sublessee fails to make the Aircraft available to Sublessor on a timely basis for inspection and redelivery pursuant to Section 18.1 and Appendix H (whether such failure is due to any act or omission of Sublessee or any other circumstance whatsoever), the Term shall be extended until the time when the Aircraft has been redelivered to Sublessor in full compliance with the Sublease, for the sole purpose of enabling such non-compliance or failure to be promptly rectified, and during such extension period:

18.2.1 Sublessee shall not use the Aircraft in flight operations except those related directly to the redelivery of the Aircraft to Sublessor;

18.2.2 all Sublessee's obligations and covenants under the Sublease will remain in full force until Sublessee so redelivers the Aircraft; and

18.2.3 Sublessee shall pay Extended Term Rent to Sublessor, calculated on a per diem basis and payable on the earlier to occur of (i) Sublessee's compliance with the redelivery obligations under the Sublease or (ii) the day in each calendar month after the Expiration Date that corresponds with the Expiration Date.

Any such extension shall not prejudice Sublessor's right to treat such non-compliance or failure as an Event of Default at any time, and to enforce such rights and remedies as may be available to Sublessor in respect thereof under the terms of the Sublease or applicable Law. Without limiting the generality of the foregoing, Sublessee's Basic Rent obligation under paragraph (c) above shall be without prejudice to Sublessor's rights to cancel or terminate the leasing of the Aircraft and to indemnification under this Agreement.

Sublessor may elect (either on first tender of the Aircraft by Sublessee or at any time during the said extension period) to accept redelivery of the Aircraft notwithstanding non-compliance with Section 18.1 or Appendix H, in which case Sublessee will indemnify Sublessor and provide cash to Sublessor (in an amount satisfactory to Sublessor) as security for that indemnity in respect of the cost to Sublessor of putting the Aircraft into the condition required by the Sublease.

18.2.4 Redelivery. Upon request of Sublessor, at redelivery Sublessee will provide to Sublessor all documents necessary to export the Aircraft from the Habitual Base (including a valid and subsisting export license and export certificate of airworthiness for the Aircraft) or required in relation to the deregistration of the Aircraft with the Aviation Authority.

18.2.5 Acknowledgement. Provided Sublessee has complied with its obligations under Section 18 and Appendix H, following redelivery of the Aircraft by Sublessee to Sublessor at the Return Location, Sublessor will deliver to Sublessee an acknowledgement confirming that Sublessee has redelivered the Aircraft to Sublessor in accordance with the Sublease which acknowledgement shall be without prejudice to Sublessor's accrued and continuing rights under the Sublease or arising by Law.

18.2.6 Storage. If Sublessor so requests, Sublessee shall provide up to [\*\*\*] days storage for the Aircraft following the last day of the Term at Sublessor's risk and expense.

**19. Total Loss.**

19.1 Total Loss of the Aircraft.

19.1.1 If a Total Loss occurs prior to Delivery of the Aircraft, the Sublease relating to such Aircraft will immediately terminate and except as expressly stated in the Sublease none of the parties will have any further obligation in respect of such Aircraft, other than pursuant to Section 16.3 and Section 3 of Appendix G.

19.1.2 If a Total Loss occurs after Delivery, Sublessee will pay the Agreed Value to Sublessor or its designee on or prior to the earlier of (i) [\*\*\*] days after the Total Loss and (ii) the date of receipt of insurance proceeds in respect of that Total Loss.

19.1.3 Subject to the rights of any insurers and reinsurers or other third party, upon irrevocable payment in full to Sublessor or its designee of the Agreed Value and all other amounts which may be or become payable to Sublessor under the Sublease, and Sublessor will without recourse or warranty (except as to the absence of Sublessor's Liens) transfer to Sublessee or its designee title to the Aircraft, on an AS IS, WHERE IS basis, and will at Sublessee's expense, execute and deliver such bills of sale and other documents and instruments as Sublessee may reasonably request to evidence (on the public record or otherwise) such transfer, free and clear of all rights of Head Lessor, Owner Participant, Sublessor and Sublessor's Liens. Sublessee shall indemnify Head Lessor, Owner Participant, Sublessor and each other Tax Indemnitee for all fees, expenses and Taxes incurred by Head Lessor, Owner Participant, Sublessor or any other Tax Indemnitee in connection with any such transfer.

19.2 Requisition. During any requisition for use or hire of the Aircraft, any Engine or Part which does not constitute a Total Loss:

19.2.1 the Basic Rent and other charges payable under the Sublease will not be suspended or abated either in whole or in part, and Sublessee will not be released from any of its other obligations (other than operational obligations with which Sublessee is unable to comply solely by virtue of the requisition); and

19.2.2 so long as no Default or an Event of Default has occurred and is continuing, Sublessee will be entitled to any compensation paid by the requisitioning authority in respect of such authority's use of the Aircraft, such Engine or such Part during the Term. Sublessee will, as soon as practicable after the end of any such requisition, cause the Aircraft to be put into the condition required by the Sublease. Sublessor will be entitled to all compensation payable by the requisitioning authority in respect of any change in the structure, state or condition of the Aircraft arising during the period of requisition, and Sublessor will apply such compensation in reimbursing Sublessee for the cost of complying with its obligations under the Sublease in respect of any such change, but, if any Default or an Event of Default has occurred and is continuing, Sublessor may apply the compensation in or towards settlement of any amounts owing by Sublessee under the Sublease and/or under any Other Sublease Agreement.

**20. Miscellaneous.**

20.1 Entire Agreement. This Agreement and, with respect to Sections 4.5, 6.9, 6.96.11, 7.1, 7.6.7, 10.2.3, 10.2.8, 11.4 and 17.2, together with the ATSA constitutes the entire agreement between Sublessor and Sublessee with respect to the Aircraft and supersedes any and all previous understandings, commitments, agreements or representations whatsoever, whether oral or written, including any and all terms sheets, letters of intent or similar documents.

20.2 Illegality; Severability.

20.2.1 Subject to Section 20.2.2, if it is or becomes unlawful in any jurisdiction for Sublessor to give effect to any of its obligations as contemplated by this Agreement or to continue its obligations under this Agreement, Sublessor may by notice in writing to Sublessee terminate the leasing of the Aircraft, such termination to take effect on the latest date (the "Illegality Date") on which Sublessor may continue such leasing and such obligations without being in breach of applicable Regulations, and Sublessee will forthwith redeliver the Aircraft to Sublessor in accordance with Section 18. Without prejudice to the foregoing, Sublessor will consult in good faith with Sublessee up to the Illegality Date as to any steps that may be taken (at no cost to Sublessor) to restructure the transaction to avoid such unlawfulness but will be under no obligation to take any such steps.

20.2.2 Severability. If a provision of the Sublease is or becomes illegal, invalid or unenforceable in any jurisdiction, that will not affect:

- (a) the legality, validity or enforceability in that jurisdiction of any other provision of this Agreement; or
- (b) the legality, validity or enforceability in any other jurisdiction of that or any other provision of this Agreement.

20.3 Amendment and Waiver. This Agreement may not be amended, suspended, superseded or otherwise modified except by a written instrument, expressly identifying the modifications made and signed by the authorized representative of both Parties. No waiver will be effective under this Agreement except by a written instrument, expressly identifying the rights waived and signed by the authorized representative of the relevant Party to be bound by the waiver. A waiver regarding any breach or Default will not constitute a waiver with respect to any different or subsequent Default unless expressly provided in such waiver instrument. Without limiting the generality of the foregoing, a Party will not be deemed to modify any term or waive any right or remedy under this Agreement by failing to insist on compliance with any of the terms of this Agreement or by failing in one or more instances to exercise any right under this Agreement.

20.4 Governing Law; Jurisdiction; WAIVER OF JURY TRIAL.

20.4.1 THE PARTIES HERETO AGREE THAT THE SUBLEASE AND ANY CLAIM, CONTROVERSY OR DISPUTE ARISING UNDER OR RELATED TO THE SUBLEASE, AND ALL ISSUES CONCERNING THE RELATIONSHIP OF THE PARTIES AND THE ENFORCEMENT OF THE RIGHTS AND DUTIES OF THE PARTIES, SHALL BE GOVERNED BY, AND CONSTRUED IN ACCORDANCE

WITH, THE GOVERNING LAW WITHOUT REGARD TO ANY CONFLICTS OF LAW PRINCIPLES, EXCEPT SECTIONS 5-1401 AND 5-1402 OF THE NEW YORK GENERAL OBLIGATIONS LAW, WHICH THE PARTIES HERETO AGREE APPLY TO THIS AGREEMENT. THE PARTIES AGREE THAT THE SUBLEASE WAS DELIVERED IN THE STATE OF NEW YORK.

20.4.2 Pursuant to and in accordance with Section 5-1402 of the New York General Obligations Law, Sublessee and Sublessor each agree that the United States District Court for the Southern District of New York and any New York state court sitting in the County of New York, New York, and all related appellate courts, are to have non-exclusive jurisdiction to settle any disputes arising out of or relating to the Sublease and submits itself and its property to the non-exclusive jurisdiction of the foregoing courts with respect to such dispute.

20.4.3 Without prejudice to any other mode of service, each of Sublessee and Sublessor consents to service of process by facsimile or prepaid mailing by air mail, certified or registered mail of a copy of the process to the other at the facsimile number or address, as applicable, set forth in this Agreement or as otherwise notified to the other pursuant to this Agreement.

20.4.4 Each of Sublessee and Sublessor:

(a) waives to the fullest extent permitted by Law any objection which it may now or hereafter have to the courts referred to in Section 20.4.2 on grounds of inconvenient forum or otherwise as regards proceedings in connection with the Sublease;

(b) waives to the fullest extent permitted by Law any objection which it may now or hereafter have to the laying of venue of any suit, action or proceeding arising out of or relating to the Sublease brought in the courts referred to in this Section 20.4; and

(c) agrees that a judgment or order of any court referred to in Section 20.4.2 in connection with the Sublease is conclusive and binding on it and may be enforced against it in the courts of any other jurisdiction as if made by the highest court in that other jurisdiction and accordingly Sublessee will not seek to, nor be entitled to, contest and/or delay and/or obstruct registration or enforcement of any such judgment and/or award and/or order on grounds of public policy or otherwise.

(d) This Section 20.4 shall survive, continue to take full effect and not merge in any order or judgment and nothing in this Section 20.4 limits the right of either party to bring proceedings against the other in connection with the Sublease:

- (i) in any other court of competent jurisdiction; or
- (ii) concurrently in more than 1 jurisdiction.



20.4.5 Each of Sublessee and Sublessor irrevocably and unconditionally:

(a) agrees that if the other brings legal proceedings against it or its assets in relation to the Sublease no sovereign or other immunity from such legal proceedings (which will be deemed to include suit, court jurisdiction, attachment prior to judgment, attachment in aid of execution of a judgment, other attachment, the obtaining of judgment, execution of a judgment or other enforcement or legal process or remedy) will be claimed by or on behalf of itself or with respect to its assets;

(b) waives any such right of immunity which it or its assets now has or may in the future acquire and agrees that the foregoing waiver shall have the fullest extent permitted under the Foreign Sovereign Immunities Act of 1976 of the United States of America and is intended to be irrevocable for the purposes of such act; and

(c) waives any requirement, of any kind whatsoever, for Sublessor to provide any form of security in respect of the payment of any damages, costs, expenses or any other financial obligation resulting from the commencement or prosecution of proceedings or the making of or service of any order and Sublessee undertakes (x) not to challenge the validity of any proceedings or the making of any orders without any requirement for the provision of such security (y) to advise any court upon Sublessor's request that Sublessee requires no such security and (z) to provide security itself for any third party claims arising out of or in connection with such proceedings and/or orders.

20.4.6 EACH OF SUBLESSEE AND SUBLESSOR HEREBY IRREVOCABLY AND UNCONDITIONALLY WAIVES ANY AND ALL RIGHTS TO A JURY TRIAL IN RESPECT OF ANY CLAIM OR CAUSE OF ACTION BASED UPON OR ARISING OUT OF THE SUBLEASE OR ANY DEALINGS BETWEEN THEM RELATING TO THE SUBJECT MATTER OF THE TRANSACTIONS CONTEMPLATED THEREBY OR THE SUBLESSOR/SUBLESSEE RELATIONSHIP BEING ESTABLISHED, INCLUDING, CONTRACT CLAIMS, TORT CLAIMS, BREACH OF DUTY CLAIMS AND OTHER COMMON LAW AND STATUTORY CLAIMS. EACH OF SUBLESSOR AND SUBLESSEE REPRESENTS AND WARRANTS THAT EACH HAS REVIEWED AND VOLUNTARILY WAIVES ITS JURY TRIAL RIGHTS FOLLOWING CONSULTATION WITH ITS LEGAL COUNSEL. THIS WAIVER IS IRREVOCABLE, AND THIS WAIVER SHALL APPLY TO ANY SUBSEQUENT AMENDMENTS, RENEWALS, SUPPLEMENTS OR MODIFICATIONS TO THE SUBLEASE. IN THE EVENT OF LITIGATION, THIS SECTION 20.4 MAY BE FILED AS A WRITTEN CONSENT TO A TRIAL BY THE COURT.

20.5 Legal Costs and Expenses. Sublessor and Sublessee each will bear the cost of their own legal fees, inspection and appraisal fees, and related expenses associated with the negotiation, preparation and execution of this Agreement, and Sublessor and Sublessee will split evenly the fees and expenses charged by Special FAA Counsel (and otherwise incurred) in performing the filings and registrations required in Section 5.

20.6 DISCLAIMER OF DAMAGES. EXCEPT FOR LOSSES, DAMAGES, OR LIABILITIES: (A) ARISING UNDER A PARTY'S INDEMNIFICATION OBLIGATIONS PURSUANT TO SECTION 10; (B) TO THE EXTENT ARISING OUT OF ANY BREACH OF A PARTY'S OBLIGATIONS UNDER THE NDAS (AS DEFINED IN THE ATSA); OR (C) CAUSED BY A PARTY'S GROSS NEGLIGENCE OR WILLFUL, FRAUDULENT OR CRIMINAL MISCONDUCT, UNDER NO CIRCUMSTANCES WILL ANY PARTY BE LIABLE FOR ANY SPECIAL, INCIDENTAL, CONSEQUENTIAL, LOST PROFITS, OR INDIRECT DAMAGES ARISING FROM OR IN RELATION TO THIS AGREEMENT, REGARDLESS AS TO THE CAUSE OF ACTION AND HOWEVER ALLEGED OR ARISING.

20.7 Further Assurances. Sublessee shall execute and deliver all such instruments and take all such actions as Sublessor may from time to time reasonably request to effectuate and perfect fully the purposes of this Sublease and any or all of Sublessor's rights, title, interest, benefits or remedies hereunder, including to effect an assignment of the Sublease.

20.8 Notices.

20.8.1 All notices and other communications under this Agreement will be in writing and will be personally delivered, sent by facsimile (with electronic confirmation) or e-mail, or delivered by a nationally-recognized courier for overnight delivery to either Party to the address of that Party set forth below. Such notice or other communication will be deemed to have been given or made and will be deemed to have been received: (a) when sent by personal delivery, upon actual delivery or the intended recipient's refusal to accept delivery; (b) when sent by nationally recognized courier for overnight delivery, the next Business Day after being sent by such courier for such delivery; (c) when sent by fax, the same day as transmitted if transmitted during the normal business hours of the recipient or the next Business Day if transmitted after the normal business hours of the recipient as reflected by an electronic confirmation or receipt; (d) when sent by email, on the day acknowledged in writing (email or otherwise) by the recipient Party but only to the extent such email notice has been sent to an employee of the recipient Party having knowledge of the matter contained in the notice (and, in the case of notice to Sublessee, with a copy to [\*\*\*) and is conspicuously identified as a notice under this Agreement. No objection may be made to the manner of delivery of any written notice actually received by a Party. The addresses for the Parties are:

- (i) If to Sublessor:  
Amazon.com Services LLC  
Attention: Director, Amazon Air  
(if by USPS)  
P.O. Box 81226  
(if by courier)  
410 Terry Avenue North  
Seattle WA 98109-5210  
Fax: [\*\*\*)  
Phone: [\*\*\*)

With a copy:

Attention: General Counsel  
(if by USPS)  
P.O. Box 81226  
(if by courier)  
410 Terry Avenue North  
Seattle WA 98109-5210  
Email: [\*\*\*]

(ii) If to Sublessee:

Sun Country, Inc.  
1300 Corporate Center Curve  
Eagan, MN 55121  
Attention: CEO  
Email: [\*\*\*]  
Phone: [\*\*\*]

With a copy:

Attention : General Counsel  
1300 Corporate Center Curve  
Eagan, MN 55121  
Email: [\*\*\*]  
Phone: [\*\*\*]

20.8.2 Either Party may, by notice to the other delivered in accordance with this Section 20.8, designate another address as its address for notice under this Agreement.

20.9 Counterparts. Each Party may effect the execution and delivery of this Agreement, any Appendix, any Schedule, or any amendment or addendum to same by facsimile or electronic transmission (including in portable document format or by electronic signature) of one or more signed counterparts that together will constitute one and the same instrument.

#### 20.10 Brokers.

20.10.1 No Brokers. Each of the Parties hereto represents and warrants to the other that it has not employed any brokers or sale agents in the creation of or the negotiations relating to this Agreement, nor has it given any brokers or sales agents such broad powers as to encompass the transactions described in this Agreement, and each Party will indemnify and hold harmless the other Party by reason of any breach or alleged breach by such Party of its representation and warranty under this Section 20.10.1.

20.10.2 Indemnity. Without duplication of Sublessee's indemnification obligations hereunder, the Sublessee agrees to indemnify and hold the Sublessor harmless from and against any and all claims, suits, damages, costs and expenses (including, reasonable legal fees and expenses) asserted by any agent, broker or other third party for any commission or compensation of any nature whatsoever based upon the Sublease or the Aircraft, if such claim, suit, damage, cost or expense arises out of any breach by the indemnifying party, its employees or agents of Section 20.10.

20.11 Financing Parties. Sublessee understands and acknowledges that: (a) the Sublessor is party to the Head Lease whereby it leases the Aircraft from the Head Lessor; (b) the Aircraft may be subject to one or more security interests from time to time as the result of Head Lessor, Owner Participant or an Affiliate of Head Lessor or Owner Participant borrowing funds from one or more Financing Parties, and (c) as a result, Head Lessor may be required to collaterally assign part or all of its interest in the Aircraft and in and under this Agreement to secure the performance of its repayment and other obligations owing to the Financing Parties. Sublessee agrees that, upon the written direction of Sublessor and provided that reasonable notice has been provided, it will consent to any such collateral assignment of Head Lessor's or Sublessor's rights under this Agreement if such collateral assignment is in form and substance satisfactory to Sublessee acting reasonably, except that Sublessor will reimburse Sublessee for any reasonable and documented out-of-pocket expenses associated with complying with this Section 20.11 (including Sublessee's attorney's fees) and such collateral assignment will not increase Sublessee's obligations or reduce Sublessee's rights under this Agreement or under the ATSA. Head Lessor, Owner Participant and any Financing Parties shall be third party beneficiaries of the terms of this Sublease.

20.12 Early Termination Option. Sublessor shall have the option to terminate the leasing of the Aircraft under this Sublease at any time (the last day of such term as set forth in the Termination Notice, the "Early Termination Date"); provided that:

- (a) Sublessor shall give Sublessee notice in writing (the "Termination Notice") of exercise of such option not less than [\*\*\*] months prior to the Early Termination Date (or immediately if the "Carrier Work Order" (as such term is defined in the ATSA) for the Aircraft is terminated for any reason), which Termination Notice shall be irrevocable;
- (b) With effect from the receipt by Sublessee of the Termination Notice, the Sublease shall be automatically amended so that the Expiration Date is the Early Termination Date, but all other provisions of the Sublease shall remain in full and unvaried force and effect.

20.13 Construction. Each appendix and schedule associated with this Agreement is hereby incorporated by reference, as if fully set forth herein, and each reference to an "Appendix" or "Schedule" in this Agreement will include all subsections or portions of such appendix or schedule, as same may be amended, restated, or supplemented from time to time. If any provision of this Agreement is determined to be unenforceable in any jurisdiction, the Parties intend that this Agreement be enforced in such jurisdiction as if the unenforceable provisions were not present and that any partially valid and enforceable provisions be enforced in such jurisdiction to the extent that they are enforceable, and further agree to substitute for the invalid provision a valid provision (with respect to such jurisdiction) which most closely approximates the intent and economic effect of the invalid provisions. The section headings of this Agreement are for convenience only and have no interpretive value. References to currency or "\$" in this Agreement refer to the Dollar unless otherwise expressly noted. Unless the context otherwise requires, as used in this Agreement, all terms used in the singular will be deemed to refer to the plural as well, and vice versa. The use of the word "including" and similar terms in this Agreement will be construed

without limitation. References in this Agreement to “Business Days” will refer to each day other than a Saturday or Sunday or a day that commercial banking institutions in Seattle, Washington and New York, New York are authorized or required by Law to remain closed and “days” means consecutive calendar days. Each Party and its counsel has reviewed and jointly participated in the establishment of this Agreement.

20.14 Cooperation. Each Party will cooperate with the other Party in good faith in the performance of its respective activities contemplated by this Agreement through, among other things, making available, as reasonably requested by the other Party, such management decisions, information, approvals, and acceptances in order that such activities may be accomplished in a proper, timely and efficient manner. Except as expressly provided otherwise, where agreement, approval, acceptance, or consent of a Party is required by any provision of this Agreement, such action will not be unreasonably withheld or delayed.

[Signature Page Follows]

E-77

**IN WITNESS WHEREOF**, this Agreement has been duly executed and delivered by duly authorized officers of the Parties on the date first written above.

**SUBLESSOR:**

**AMAZON.COM SERVICES LLC**

By: \_\_\_\_\_

Name: \_\_\_\_\_

Title: \_\_\_\_\_

**SUBLESEE:**

**SUN COUNTRY, INC.**

By: \_\_\_\_\_

Name: \_\_\_\_\_

Title: \_\_\_\_\_

**Appendix A**  
**to**  
**Aircraft Sublease Agreement (MSN [●])**

**DESCRIPTION OF AIRFRAME AND ENGINES**

1. **Description of Airframe.**

Manufacturer:	The Boeing Company
Model Number:	737-83N
Serial Number:	
U.S. Registration No.:	

2. **Description of Engines.**

Manufacturer:	CFM International, Inc.
Model Number:	CFM56-7B24
Serial Numbers:	

Each of the Engines has more than 1750 pounds of thrust or its equivalent.

**Appendix B**  
**to**  
**Aircraft Sublease Agreement (MSN [●])**

**PARTICULAR COMMERCIAL CONDITIONS**

*(Following confidential financial terms redacted from Sublease counterpart filed with FAA)*

[\*\*\*]

E-80



---

**Appendix C**  
**to**  
**Aircraft Sublease Agreement (MSN [●])**

[Reserved]

E-81

**Appendix D**  
**to**  
**Aircraft Sublease Agreement (MSN [●])**

**ATTACHED FORM OF TECHNICAL ACCEPTANCE CERTIFICATE**  
**(Executed as a Condition of Delivery)**

This Certificate of Acceptance is delivered on the date set out below by [●] (“Sublessee”) to [●] (“Sublessor”) pursuant to the Aircraft Sublease Agreement (MSN [●]) dated as of [●] between Sublessor and Sublessee (the “Sublease”). The capitalized terms used in this Certificate shall have the meaning given to such terms in the Sublease unless otherwise indicated.

**DETAILS OF ACCEPTANCE**

Sublessee hereby confirms to Sublessor that Sublessee has at [●] o'clock on this [●] day of [●], at [●], technically accepted the following, in accordance with the provisions of the Sublease:

	Serial Number	Type
<b>Aircraft</b>		
<b>Engine 1</b>		
<b>Engine 2</b>		
<b>APU</b>		
<b>Fuel Status</b>		

Hours and Cycles data – per the attached summary.

**Documentation – Equipment (attached):**

- LOPA
- Emergency equipment drawing
- Emergency and Loose Equipment list
- Aircraft Documents
- Engine Disc Sheets

**ACCEPTANCE:**

Sublessor hereby confirms that it will reimburse Sublessee for the correction of the deferred items, if any, listed in Attachment 2 hereto.

Sublessee hereby confirms that the Aircraft is airworthy and that the Aircraft, Engines, Parts and Aircraft Documents are technically acceptable to it, satisfy all of the Delivery Condition Requirements and are in the condition for delivery and acceptance as required under the Sublease.

**IN WITNESS WHEREOF**, Sublessee and Sublessor have, by their duly authorized representative, executed this Certificate of Acceptance on the date in paragraph 1 above.

**SUBLESSEE: [●]**

By: \_\_\_\_\_  
Name:  
Title:

**SUBLESSOR: [●]**

By: \_\_\_\_\_  
Name:  
Title:

to

Form of Technical Acceptance Certificate

**HOURS AND CYCLES DATA SUMMARY**

**Schedule to Certificate of Acceptance: Form for New Aircraft:**

**HOURS AND CYCLES DATA** (as of Delivery Date)

**Airframe:**

Time Since New \_\_\_\_\_

Cycles Since New \_\_\_\_\_

**Landing Gear (Main and Nose)**

Time Since New \_\_\_\_\_

Cycles Since New \_\_\_\_\_

**Engines**

Position Left Hand s/no.

Time Since New: \_\_\_\_\_

Cycles Since New: \_\_\_\_\_

Position Right Hand s/no.

Time Since New: \_\_\_\_\_

Cycles Since New: \_\_\_\_\_

**Auxiliary Power Unit**

Flight Hours/APU Hours

(specify as applicable) since new: \_\_\_\_\_

**Schedule to Certificate of Acceptance: Form for Used Aircraft:**

**HOURS AND CYCLES DATA** (as of Delivery Date)

**Total Hours**

**Total Cycles**

**Airframe:**



**Hours since last Refurb**  
**Cycles since last Refurb**  
**Cycles Remaining to First Restriction**  
**Item to First Restriction**

**Auxiliary Power Unit:**

S/N

TSN

Date of Last Heavy  
Shop Visit

Time Since Last  
Heavy Shop  
Visit

E-87

---

ATTACHMENT 2

to

Form of Technical Acceptance Certificate

EXCEPTIONS

E-88



---

**Appendix E**  
**to**  
**Aircraft Sublease Agreement (MSN [●])**

**ATTACHED FORM OF SUBLEASE SUPPLEMENT**  
**(Executed Contemporaneously with Delivery)**

E-89

**SUBLEASE SUPPLEMENT NO. 1**  
**(MSN [●])**

Dated: [●], 20[●]

**PURSUANT TO THE AIRCRAFT SUBLEASE AGREEMENT (MSN [●])** (the “Agreement”) dated on [●], 20 between Amazon.com Services LLC, a Delaware limited liability company (“Sublessor”), as sublessor, and Sun Country, Inc. a Minnesota corporation (“Sublessee”), as lessee, this Sublease Supplement No. 1 is executed by the parties hereto to confirm that at [●]a.m./p.m. ([●]Time) on this [●] day of [●], 2019:

(a) the following described airframe:

Manufacturer:	The Boeing Company
Model:	737-83N
Manufacturer’s Serial No.:	[●]
U.S. Registration No.:	[●]

(b) together with the two (2) following described aircraft engines (each having more than 1750 pounds of thrust or the equivalent of such thrust):

Manufacturer:	CFM International, Inc.
Model:	CFM56-7B24
Manufacturer’s Serial Nos.:	[●] and [●]

(c) together with the “Aircraft Documents” (as listed in Attachment 1 to the “Technical Acceptance Certificate,” as defined in the Agreement), were delivered by Sublessor to Sublessee and were accepted by Sublessee under and subject to the terms and conditions of the Agreement, while the Aircraft was located at [●]. The parties hereto confirm that on the date hereof: (i) the “Aircraft” (as defined by the Agreement) was duly accepted by Sublessee for leasing under the Agreement; (ii) the Aircraft became subject to and governed by the provisions of the Agreement; (iii) the Agreement is in full force and effect; (iv) all the terms and provisions of the Agreement are hereby fully incorporated herein; and (v) Sublessee became obligated to make the payments provided for in the Agreement.

Expiration Date. Sublessor and Sublessee further acknowledge and agree that the Expiration Date for purposes of the Agreement is [●].

**[Signature Page Follows]**

**IN WITNESS WHEREOF**, this Sublease Supplement No. 1 (MSN [•]) has been duly executed and delivered by the duly authorized officers of the Parties at the time and on the date written above.

**SUBLESSOR:**

**AMAZON.COM SERVICES LLC:**

By: \_\_\_\_\_

Name: \_\_\_\_\_

Title: \_\_\_\_\_

**SUBLESSEE:**

**SUN COUNTRY, INC.:**

By: \_\_\_\_\_

Name: \_\_\_\_\_

Title: \_\_\_\_\_

**Appendix F to  
Aircraft Sublease Agreement (MSN[●])**

**ATTACHED FORM OF RETURN RECEIPT**

**(Executed contemporaneously with Return of Aircraft in compliance with the Return  
Condition Requirements)**

**RETURN RECEIPT**

Dated: [●]

**PURSUANT TO THE AIRCRAFT SUBLEASE AGREEMENT (MSN [●])** (the “Agreement”) dated on [●], 20[●] between Amazon.com Services LLC (“Sublessor”), as sublessor, and Sun Country, Inc. (“Sublessee”), as sublessee, this Return Receipt is executed by the parties hereto to confirm that at [●] a.m./p.m. ([●] Time) on this day of [●],[●] the following described aircraft (as defined more fully in the Agreement, the “Aircraft”) was redelivered by Sublessee to Sublessor while the Aircraft was located at [●] pursuant to the terms and conditions of the Agreement:

(a) The following described airframe (the “Airframe”):

Manufacturer:	The Boeing Company
Model Number:	737-83N
Manufacturer’s Serial Number:	_____
U.S. Registration No.:	N_____
Total Time:	_____
Total Cycles:	_____
Time Since Major Check:	_____
Cycles Since Major Check:	_____
Type of Last Major Check	_____
Time to Next Major Check	_____

(b) together with the following described two aircraft engines (the “Engines”):

Manufacturer:	CFM International, Inc.
Model Number:	CFM56-7B24
Serial Number:	_____
Total Time:	_____
Total Cycles:	_____
Time Since Overhaul:	_____
Cycles Since Overhaul:	_____
Cycles Remaining Until Next Overhaul	_____
Serial Number:	_____
Total Time:	_____
Total Cycles:	_____

Time Since Overhaul: \_\_\_\_\_  
Cycles Since Overhaul: \_\_\_\_\_  
Cycles Remaining Until  
Next Overhaul \_\_\_\_\_

(c) together with the following described landing gears:

Manufacturer: \_\_\_\_\_  
Model Number(s): \_\_\_\_\_  
Serial Number(s): \_\_\_\_\_  
Time Since Overhaul: \_\_\_\_\_  
Cycles Since Overhaul: \_\_\_\_\_  
Cycles Since Overhaul \_\_\_\_\_

Manufacturer: \_\_\_\_\_  
Model Number(s): \_\_\_\_\_  
Serial Number(s): \_\_\_\_\_  
Time Since Overhaul: \_\_\_\_\_  
Cycles Since Overhaul: \_\_\_\_\_  
Cycles Since Overhaul \_\_\_\_\_

Manufacturer: \_\_\_\_\_  
Model Number(s): \_\_\_\_\_  
Serial Number(s): \_\_\_\_\_  
Time Since Overhaul: \_\_\_\_\_  
Cycles Since Overhaul: \_\_\_\_\_  
Cycles Since Overhaul \_\_\_\_\_

(d) together with the following auxiliary power unit (APU):

Manufacturer: \_\_\_\_\_  
Model Number: \_\_\_\_\_  
Serial Number: \_\_\_\_\_  
Time Since Overhaul: \_\_\_\_\_  
Cycles Since Overhaul: \_\_\_\_\_

(e) together with the following thrust reverser halves:

Manufacturer: \_\_\_\_\_  
Model Number: \_\_\_\_\_  
Serial Number: \_\_\_\_\_  
Time Since Overhaul: \_\_\_\_\_  
Cycles Since Overhaul: \_\_\_\_\_

Manufacturer: \_\_\_\_\_  
Model Number: \_\_\_\_\_  
Serial Number: \_\_\_\_\_  
Time Since Overhaul: \_\_\_\_\_  
Cycles Since Overhaul: \_\_\_\_\_

---

Manufacturer: \_\_\_\_\_  
Model Number: \_\_\_\_\_  
Serial Number: \_\_\_\_\_  
Time Since Overhaul: \_\_\_\_\_  
Cycles Since Overhaul: \_\_\_\_\_

Manufacturer: \_\_\_\_\_  
Model Number: \_\_\_\_\_  
Serial Number: \_\_\_\_\_  
Time Since Overhaul: \_\_\_\_\_  
Cycles Since Overhaul: \_\_\_\_\_

(f) together with the Aircraft Documents (as detailed in Attachment 1 hereto).

Sublessee hereby confirms that it will reimburse Sublessor for the correction of the deferred items, if any, listed in Attachment 2 hereto.

Sublessor hereby confirms that it has accepted the return of the Aircraft and of the Aircraft Documents under the terms of this Agreement and certifies that it considers the Aircraft to comply with the Return Condition Requirements set forth in the Agreement.

**[Signature Page Follows]**

**IN WITNESS WHEREOF**, this Return Receipt has been duly executed and delivered by duly authorized officers of the Parties at the time and on the date written above.

**SUBLESSOR:**

**AMAZON.COM SERVICES LLC**

By: \_\_\_\_\_

Name: \_\_\_\_\_

Title: \_\_\_\_\_

**SUBLESSEE:**

**SUN COUNTRY, INC.**

By: \_\_\_\_\_

Name: \_\_\_\_\_

Title: \_\_\_\_\_

Attachment 1: Aircraft Documents

Attachment 2: Deferred Items





---

**RETURN RECEIPT**

**LIST OF AIRCRAFT DOCUMENTS**

[To Be Provided]

E-97



---

**RETURN RECEIPT**

**DEFERRED ITEMS**

[To Be Provided]

E-99

**Appendix G to  
Aircraft Sublease Agreement (MSN [●])**

**PRE-DELIVERY PROCEDURES AND DELIVERY CONDITION REQUIREMENTS**

**1. Licenses**

- (a) It is the responsibility of Sublessee to obtain all licenses, permits or approvals necessary to export or transport the Aircraft from the Delivery Location (although Sublessor agrees to cooperate with Sublessee in obtaining the same) at Sublessor's (or Head Lessor's) cost.
- (b) Sublessor will provide Sublessee with any required data and information relating to the Aircraft or Sublessor as are reasonably available to Sublessor for the purposes of obtaining any such licenses, permits or approvals.

**2. Inspection**

- (a) Subject to any applicable purchase agreement, Sublessee shall inspect the Aircraft. To check that the Aircraft fulfils those Delivery Condition Requirements which cannot be checked on the ground, Sublessor will arrange a demonstration flight at its, or previous operator's, cost. This flight would be performed in line with Manufacturer's recommendations for in-service aircraft (subject to then state of registry and state of operator requirements) with up to[\*\*\*]representatives of Sublessee on board as observers.
- (b) If Sublessee's inspection of the Aircraft shows that the Aircraft does not fulfil the Delivery Condition Requirements, Sublessor will correct any Discrepancy and make the Aircraft available for re-inspection by Sublessee provided that, in Sublessor's reasonable opinion, it is not impracticable or prohibitively expensive to correct the Discrepancy.
- (c) If Sublessor notifies Sublessee that it does not intend to correct the Discrepancy, either party may terminate the Sublease. In the event of such a termination, all obligations of each party under the Sublease will end on the date of such notice. Sublessee will remain obligated under its indemnity set forth in Section 3 of Appendix G.
- (d) Sublessee will carry out the inspections contemplated by Appendix I (Cargo Aircraft Cabin Interior Standard). Sublessor will arrange for replacements, repairs or repainting required per Appendix I to be done at Sublessor's cost prior to Delivery. If any such task is not completed prior to Delivery or if there are any Discrepancies agreed by the parties at Delivery, which have not been remedied by Sublessor, but which do not affect the airworthiness or operation of the Aircraft, then these will be noted on the Certificate of Acceptance. Sublessee may remedy those Discrepancies after Delivery at a time convenient to Sublessee during the Term and Sublessor will reimburse Sublessee for the reasonable costs (as mutually agreed in advance) incurred in performing that work. Reimbursement would be subject to receipt by Sublessor of an invoice from Sublessee with supporting documentation for the costs incurred and confirming completion of the work.

**3. Indemnity**

SUBLESSEE IS RESPONSIBLE FOR AND WILL INDEMNIFY EACH INDEMNITEE AGAINST ALL LOSSES ARISING FROM DEATH OR INJURY TO ANY OBSERVER, REPRESENTATIVE OR ANY EMPLOYEE OF SUBLESSEE (BUT NOT OF ANY INDEMNITEE) IN CONNECTION WITH THE INSPECTION OF THE AIRCRAFT WHETHER OR NOT SUCH LOSSES ARISE OUT OF OR ARE ATTRIBUTABLE TO ANY ACT OR OMISSION, NEGLIGENT OR OTHERWISE, OF ANY INDEMNITEE.

**4. DELIVERY CONDITION REQUIREMENTS**

THE DELIVERY CONDITION REQUIREMENTS DESCRIBED IN THIS APPENDIX G ARE SOLELY A DESCRIPTION OF THE CONDITION THE AIRCRAFT MUST BE IN FOR SUBLESSEE TO BE OBLIGED TO ACCEPT THE DELIVERY OF THE AIRCRAFT UNDER THE SUBLEASE AND SHALL NOT BE CONSTRUED AS A REPRESENTATION, WARRANTY OR AGREEMENT OF ANY KIND WHATSOEVER, EXPRESS OR IMPLIED, BY SUBLESSOR WITH RESPECT TO THE AIRCRAFT OR ITS CONDITION, ALL OF WHICH HAVE BEEN DISCLAIMED BY SUBLESSOR AND WAIVED BY SUBLESSEE AS SET FORTH IN THE SUBLEASE.

The definitions used in this Appendix G are as defined below:

Engine Thrust Setting:	[***]
Minimum APU Limit:	[***]
Minimum Component Calendar Life:	[***]
Minimum Component Cycles:	[***]
Minimum Component Flight Hours:	[***]
Minimum Engine Cycles:	[***]
Minimum Engine LLP Cycles:	[***]
Minimum Engine Flight Hours:	[***]
Minimum Landing Gear Calendar Time:	[***] Months
Minimum Landing Gear Cycles:	[***]
Required EGT Margin:	Each Engine will have sufficient EGT margin to achieve the Minimum Engine Hours and Minimum Engine Cycles at full take-off thrust on flat rated seal level day but not less than [***] degrees.

Sublessee will check for the following Delivery Conditions Requirement:

#### 4.1 General

##### **The Aircraft:**

- (a) has been thoroughly cleaned prior to Delivery and is in the configuration agreed herein;
- (b) has installed the full complement of equipment, parts, accessories, furnishings, required markings and loose equipment as are normally installed in the Aircraft for continued regular service and the Aircraft (including the Aircraft Documents) is in a condition suitable for immediate operations under IR-OPS or FAR Part 121 (as applicable), without waiver or restriction;
- (c) has a valid certificate of airworthiness;
- (d) complies with the Manufacturer's original specifications, except for example as modified by any previous operator in accordance with service bulletins, ADs or similar requirements;
- (e) has undergone, immediately prior to Delivery, the Airframe check provided herein as a Delivery Condition Requirement;
- (f) (i) complies with all outstanding ADs affecting that model of Aircraft issued prior to the Anticipated Delivery Month and within the AD Compliance Period (for this purpose: compliance will be by terminating action if the latest date permitted by the AD for required compliance by terminating action falls within the AD Compliance Period and references in this sub-clause (f) to "AD Compliance Period" refer to time after Delivery, not after the Expiration Date) and (ii) is not subject to any time extensions, waivers, deviations or alternative means of compliance with any ADs or other Regulations that are non-transferable by previous operator;
- (g) has installed all applicable vendor's and manufacturer's service bulletin kits received free of charge by previous operator related to the Aircraft or, to the extent not installed, that those kits will be furnished free of charge to Sublessee;
- (h) is in such external livery as agreed herein;
- (i) has all signs and decals clean, secure and legible;
- (j) meets ICAO requirements then in effect for the noise certification of the Aircraft, without waiver or restriction;

- (k) has no open, deferred, continued, carry over or placarded log book items or watch items and that all log book discrepancies have been cleared;
- (l) has had any damage repaired to a permanent repair standard with no additional inspections or other action required in relation to such repairs. If such a repair is not achievable, then the repair shall be to a permanent repair standard, subject to Manufacturer required supplemental inspections of the highest achievable initial inspection threshold and repeat intervals. If a permanent repair with supplemental inspections has been performed and a related inspection would be required to be carried out within [\*\*\*] Cycles after Delivery, then immediately prior to Delivery, that the inspection has been carried out to clear the Aircraft for the maximum time then achievable. If there are repairs to any fatigue critical structure, requiring damage tolerance analysis, one of the following Manufacturer approvals shall be provided:
  - (1) approval providing an initial threshold for inspections and which is valid until that threshold is reached (sometimes termed by an airframe manufacturer as a stage 2 approval) and with a minimum of [\*\*\*]Cycles remaining to that threshold; or
  - (2) approval (which is not time limited) setting out the inspection requirements, including the repeat interval and inspection method (sometimes termed by an airframe manufacturer as a stage 3 approval) with a minimum of [\*\*\*] Cycles remaining until the next such inspection is required.
- (m) has all its systems serviceable and fully operational for their intended functions in accordance with the Manufacturer’s maintenance manual specifications;
- (n) has no leaks exceeding the limits specified in the Manufacturer’s maintenance manual; and
- (o) no longer has the previous operator’s logos, branding and other identifying marks.

#### 4.2 Components

- (a) Each Flight Hour and Cycle controlled Hard Time Component (other than the APU itself – but including components of the APU) has not less than the Minimum Component Flight Hours and/or the Minimum Component Cycles (whichever is more restrictive) of life remaining to the next scheduled removal, in accordance with the previous operator’s maintenance program and is supported by documentation certifying date of installation, TSO and CSO (if overhaul is the mandatory action required by the Maintenance Program) or TSR/CSR with a EASA Form 1, FAA form 8130-3 or equivalent; in this sub-paragraph “Hard Time Component” means any component which has a limited on-wing life in accordance with previous operator’s maintenance program and which can have life fully restored through appropriate maintenance;

- (b) Each calendar-limited component including safety equipment has not less than its Minimum Component Calendar Life remaining to the next scheduled removal in accordance with the previous operator's maintenance program and is supported by documentation indicating date of installation and by appropriate certification documentation indicating date of manufacture (where applicable) and date of overhaul in the form of EASA Form 1, FAA Form 8130-3 or equivalent as applicable;
- (c) Each "on-condition" and "condition-monitored" component is serviceable;
- (d) Each Airframe Life-Limited Component has not less than the Minimum Airframe Life Limited Component Flight Hours and the Minimum Airframe Life Limited Component Cycles remaining to next scheduled removal and is supported by documentation necessary to demonstrate accumulated Cycles. The certification to consist of a release certificate from the overhaul agency reflecting last repair or overhaul applicable or required by the Maintenance Program with supporting documentation listing part number, serial number, accumulated Cycles and last operator for each installed Airframe-Life Limited Component; for this purpose, "Airframe-Life Limited Component" means a component with an ultimate life which cannot be restored through appropriate maintenance.

#### 4.3 Engines

- (a) Each Engine is installed on the Aircraft and has not less than Minimum Engine Flight Hours and Minimum Engine Cycles expected life remaining to the next expected removal.

The expected life remaining is to be determined by inspection and checks accomplished before Delivery taking account, where available, of:

- (i) full borescope inspection;
- (ii) analysis of trend data;
- (iii) SLOATL assessment or minimum last [\*\*\*] qualifying flights (excluding the first flight of the day);
- (iv) maximum power assurance ground runs;
- (v) technical log analysis for a minimum of the previous [\*\*\*] months of operation;



- (vi) previous shop visit assessment (if applicable); and
- (vii) in accordance with manufacturer's maintenance manual.
- (b) Following the demonstration flight provided for by Section 2 of this Appendix G, each Engine has just completed at the Delivery Location a complete video borescope inspection of all Engine gas path modules (that inspection performed at Sublessor's expense) and a power assurance run (performed at Sublessor's expense) in accordance with Manufacturer's maintenance manual, in each case Sublessor shall use commercially reasonable efforts to ensure that Sublessee may have one representative present to witness the inspections. Any Discrepancies discovered exceeding the Engine manufacturer's in-service limits have been corrected at Sublessor's expense. Sublessor shall have provided a DVD (or other electronic media) of the borescope inspections it had performed to Sublessee. No Engine is on "watch" for any reason requiring any special or out of sequence inspection. Each Engine complies with the operations specification of the previous operator without waiver or exceptions and there being no items beyond the Engine manufacturer's in-service limits;
- (c) Each Engine Life-Limited Part has not less than the Minimum Engine LLP Cycles remaining in accordance with the manufacturer's then current limitations for the part number in question, and is supported by certification documentation necessary to demonstrate Back-To-Birth Traceability; for this purpose, "Life Limited Part" means a component with an ultimate life which cannot be restored through appropriate maintenance approved by the State of Design of the manufacturer;
- (d) Each Engine is in a condition to operate at a maximum rated take-off power at sea level under corner point or flat rate conditions and with the Required EGT Margin; and
- (e) Each Engine is rated at the Engine Thrust Setting (all delivery conditions of this paragraph being based on such Engine Thrust Setting).

#### 4.4 **Fuselage, Windows and Doors**

- (a) The fuselage is free of dents and abrasions exceeding the limits specified in the Manufacturer's maintenance manual or structural repair manual;
- (b) Cockpit windows are free of delamination exceeding the limits specified in the Manufacturer's maintenance manual or structural repair manual;
- (c) Cabin windows are substantially free of blemishes and crazing and properly sealed;

- (d) Doors are free moving, correctly rigged and fitted with serviceable seals; and
  - (e) Sublessor has supplied a survey or map of the Airframe identifying the specific location of each repair and allowable damage (e.g. dents and scratches) with a reference to the applicable approved data, accomplishment records and (if applicable) next inspection threshold.
- 4.5 **Wings and Empennage:** Leading edges are free from damage in excess of the limits specified in the Manufacturer's maintenance manual or structural repair manual.
- 4.6 **Landing Gear; Tires and Brakes**
- (a) The Landing Gear and wheel wells are clean and repaired as necessary;
  - (b) Each installed Landing Gear has not less than the Minimum Landing Gear Flight Hours and the Minimum Landing Gear Cycles and the Minimum Landing Gear Calendar Time to the next scheduled overhaul or removal, as the case may be, in accordance with the then current Manufacturer's Maintenance Planning Document;
  - (c) The tyres and brakes have not less than half of their useful life remaining; and
  - (d) The Landing Gears have full Back-To-Birth traceability such that the Aircraft Documents contain the following information since new in relation to each Landing Gear: the aircraft upon which the Landing Gear was installed, the duration of such installation and the identity of each relevant aircraft operator, the origin of each Part (when new) installed on the Landing Gear, details of expired life and particulars of all maintenance undertaken to the Landing Gear.
- 4.7 **Auxiliary Power Unit:** The APU shall have just completed a borescope inspection and shall meet all air outputs and temperature limitations under load in accordance with the Maintenance Program and the Manufacturer's maintenance manual, and any discrepancies discovered in such inspection, which exceed the APU manufacturer's in-service limits, shall be corrected at Sublessor's expense. The APU shall have not more than the Minimum APU Limit.
- 4.8 **Corrosion**
- (a) The Aircraft complies with the Manufacturer's corrosion prevention and control programme (CPCP) requirements. All CPCP inspections which would normally be accomplished while access is provided during structural inspection in accordance with the previous operator's Maintenance Program have been accomplished;

- (b) The entire fuselage is substantially free from corrosion and adequately treated and a corrosion prevention programme is in operation in accordance with the Manufacturer's Maintenance Planning Document; and
- (c) Fuel tanks are free from contamination and corrosion and a tank treatment programme was in effect during any period of storage prior to Delivery.

4.9 **Fuel:** Fuel has been measured on Delivery and the amount noted on the Certificate of Acceptance.

4.10 **Maintenance Program:** Sublessor has provided Sublessee with reasonable access to previous operator's maintenance program and the Aircraft Documents in order to facilitate the Aircraft's integration into Sublessee's fleet.

4.11 **Documents:** The Aircraft Documents are up to date and listed in the attachment to the Certificate of Acceptance. Sublessee will notify Sublessor in good time prior to Delivery of any issues it has with the Aircraft Documents so that the parties can work with the previous operator or most recent maintenance provider, where appropriate, to resolve such issues in a timely fashion before Delivery.

The Delivery Condition Requirements set forth in this Part 2 of Appendix G of the Sublease and described below are solely a description of the condition the Aircraft must be in for Sublessee to be obliged to accept the delivery of the Aircraft under the Sublease and shall not be construed as a representation, warranty or agreement of any kind whatsoever, express or implied, by Sublessor with respect to the Aircraft or its condition, all of which have been disclaimed by Sublessor and waived by Sublessee as set forth in the Sublease.

Airframe Check:

The next due heavy maintenance visit which shall include but not be limited to accomplishment of a block C Check so that all scheduled and out of phase inspection have been cleared for [\*\*\*]Flight Hours and [\*\*\*]Cycles and [\*\*\*] months. Where relevant, the work-scope and intervals (calendar and/or hourly) shall not be less than those prescribed by the then current Manufacturer's Maintenance Planning Document block maintenance program.

Weights:

The Aircraft shall have the following weights:

MTOW of [\*\*\*]Lbs.

MZFW of [\*\*\*]Lbs.

MLW of [\*\*\*]Lbs.

Airworthiness certification basis and operational standard:

FAA. In a condition suitable for immediate operation under FAR 121 requirements.

AD Compliance Period:

ADs with clearance of [\*\*\*] days or the equivalent flight hours and cycles and in the case of Engine fan blades with more than [\*\*\*] cycles since new, the fan blade dovetail ultrasonic inspection per SB 72-1033 or eddy current inspection per ESM will have been performed no more than [\*\*\*] cycles prior to Delivery.

Aircraft configuration:

Boeing 737-83N configuration with a Rigid Cargo Barrier and an ANCRA CLS capable of the following configurations full time:

- a) (11) 88" X 125" or
- b) (11) 88" X 108" or
- c) (9) 96" X 125" or
- d) (22) 62"X 88", but for this configuration (d) only subject to this configuration being certified by the Manufacturer and made available for installation without affecting the Delivery Date.

Engines:

For any Engine which has previously operated in the Arabian Gulf, North Africa, India or Pakistan prior to Delivery, such Engine shall not have operated for more than [\*\*\*] cycles or [\*\*\*] hours in that environment since last Engine Refurbishment in respect of the core module (at a minimum inclusive of high-pressure compressor, combustor and high-pressure turbine).

For any Engine which has previously operated in China prior to Delivery, such Engine shall not have operated for more than [\*\*\*] cycles or [\*\*\*] hours in that environment since last Engine Refurbishment in respect of the core module (at a minimum inclusive of high-pressure compressor, combustor and high-pressure turbine). Should Sublessor propose an engine for delivery with more than [\*\*\*] cycles operated in China since last Engine Refurbishment in respect of the core module,

---

then Sublessee agrees to discuss in good faith, without any obligation to accept, the terms under which the Sublessee may accept such engine as a contracted engine.

Livery: The fuselage shall be freshly painted in the livery as agreed with Sublessee.

**Appendix H**  
**to**  
**Aircraft Sublease Agreement (MSN [●])**

**RETURN CONDITION REQUIREMENTS**

On Return, Sublessee will redeliver the Aircraft to Sublessor in accordance with the procedures and in the condition set out below.

**FINAL INSPECTION**

Immediately prior to Return, Sublessee will make the Aircraft available to Sublessor and its designees for inspection (“Final Inspection”) to verify that the condition of the Aircraft complies with the Sublease. The Final Inspection will include, and be long enough to permit Sublessor and its designees to:

- (a) inspect the Aircraft Documents;
- (b) inspect the Aircraft, any uninstalled Parts and the APU (including a complete video borescope inspection). The inspection may include examining compartments and bays, so Sublessee will open or remove panels as reasonably required by Sublessor.
- (c) inspect the Engines, including (i) a complete video borescope inspection of (A) the low pressure and high-pressure compressors and (B) turbine area, including combustors, and (ii) engine condition runs, including full take-off power engine run-up performed in accordance with the performance test in the Manufacturer’s maintenance manual, and the Engines shall not exceed corrected limits for all parameters using temperature corrected charts, and power assurance runs; and
- (d) observe a [\*\*\*] hour demonstration flight performed by Sublessee at Sublessee’s cost (with Head Lessor’s, Owner Participant’s and Sublessor’s representatives as on-board observers).

Sublessee acknowledges that a purchaser or the next operator of the Aircraft may need to inspect the Aircraft, the Engines and the Aircraft Documents prior to redelivery. Sublessee agrees to cooperate reasonably upon reasonable prior written notice at all times during normal business hours during the Term with Sublessor and such purchaser or next operator to coordinate, assist and grant access for such inspections and/or meetings; provided that any such inspection shall not result in an unreasonable disruption to Sublessee’s business operations or to the scheduled operation of the Aircraft.

As between Sublessor and Sublessee, Sublessor is responsible for and will indemnify Sublessee against all Losses arising from the death or injury to any observer or any employee of Head Lessor, Owner Participant or Sublessor, as the case may be, in connection with the Final Inspection of the Aircraft.

When Sublessor takes redelivery, the amount of fuel on the Aircraft will be checked and compared with the amount of fuel noted in the Certificate of Acceptance at Delivery. If the Aircraft is redelivered with more fuel than at Delivery, Sublessor will pay Sublessee for the difference. If the Aircraft is redelivered with less fuel than at Delivery, Sublessee will pay Sublessor for the difference. In each case the payment will be calculated using the prevailing cost at redelivery of fuel at the Return Location.

**1. General.**

1.1. The Aircraft will be serviceable, certified for international cargo operations, with all systems functioning, and clean in accordance with international airline standards.

1.2. The Aircraft will be in compliance with then current FARs, including FAR Part 121, and will be returned with a current FAA Certificate of Airworthiness (or a certificate of airworthiness for export to the United States issued by the Aviation Authority, if not the FAA).

1.3 The Aircraft (including the Engines) will be free and clear of liens, charges and encumbrances of any nature whatsoever other than Sublessor's Liens.

Sublessee will return the Aircraft in the condition set forth in this Appendix H and as otherwise modified below:

Redelivery Check:

The next due heavy maintenance visit which shall include but not be limited to accomplishment of a block C Check so that all scheduled and out of phase inspection have been cleared for [\*\*\*]Flight Hours and [\*\*\*]Cycles and [\*\*\*] months. Where relevant, the work-scope and intervals (calendar and/or hourly) shall not be less than those prescribed by the then current Manufacturer's Maintenance Planning Document block maintenance program.

Weights:

The Aircraft shall have the following weights:

MTOW of [\*\*\*] Lbs.

MZFW of [\*\*\*] Lbs.

MLW of [\*\*\*] Lbs.

Airworthiness certification basis and operational standard:

FAA. In a condition suitable for immediate operation under FAR 121 requirements.

AD Compliance Period:

ADs with clearance of [\*\*\*] days or the equivalent flight hours and cycles and in the case of Engine fan blades with more than [\*\*\*]cycles since new, the fan blade dovetail ultrasonic inspection per SB 72-1033 or eddy current inspection per ESM will have been performed no more than [\*\*\*] cycles prior to Delivery.

Aircraft configuration:

Boeing 737-83N configuration with a Rigid Cargo Barrier and an ANCRA CLS capable of the following configurations full time:

- a) (11) 88" X 125" or
- b) (11) 88" X 108" or
- c) (9) 96" X 125" or
- d) (22) 62" X 88", if the configuration in this (d) was provided to Sublessee on the Delivery Date.

Livery:

The fuselage shall be freshly painted a livery advised by Sublessor.

**Definitions:**

Engine Thrust Setting:	***
Minimum APU Limit:	***
Minimum Component Calendar Life:	***
Minimum Component Cycles:	***
Minimum Component Flight Hours:	***
Minimum Engine Cycles:	***
Minimum Engine LLP Cycles:	***
Minimum Engine Flight Hours:	***



---

Minimum Landing Gear Calendar Time:	[***]
Minimum Landing Gear Cycles:	[***]
Required EGT Margin:	Each Engine will have sufficient EGT margin to achieve the Minimum Engine Hours and Minimum Engine Cycles at full take-off thrust on flat rated sea level day.
Redelivery Location:	Location within the 48 contiguous United States as notified by Sublessee to Sublessor or such other location as may be agreed between Sublessor and Sublessee

2. **General Condition of Aircraft at Return.**

2.1. The Aircraft will:

- (a) be thoroughly cleaned immediately prior to Return and will be in the same configuration as at Delivery subject to any post-Delivery modifications, repairs or maintenance to the Aircraft which are permitted or required by the Sublease;
- (b) have installed the full complement of equipment, parts, accessories, furnishings and loose equipment as when originally delivered to Sublessee (and, in addition, shall include any post-Delivery modifications, repairs or maintenance which are required or permitted by the Sublease) and as normally installed in the Aircraft for continued regular service. The Aircraft (including the Aircraft Documents) shall be in a condition suitable for immediate operations under IR-OPS or FAR Part 121, without waiver or restriction; and if any of the engines or parts tendered for Return with the Aircraft is not one of the Engines or Parts referred to in the Certificate of Acceptance or a Replacement Engine installed pursuant to Section 6.2 of the Sublease following the Total Loss of an Engine, Sublessor shall have no obligation to accept such engine or part unless Sublessor consents and Sublessee furnishes to Sublessor all the documents and evidence in respect of such engine or part in accordance with Section 6.2 of the Sublease, as if such engine were a Replacement Engine or such part were a replacement Part, and otherwise complies with such Section 6.2 with respect thereto;

- (c) have a valid and effective certificate of airworthiness issued by the FAA, and if required by Sublessor (at Sublessor's cost), a valid and effective export certificate of airworthiness issued not earlier than [\*\*\*] days prior to the Return;
- (d) comply with the manufacturer's original specifications as at the Delivery Date, except as modified during the Term in accordance with the Manufacturer's service bulletins or letters, ADs, FAA approved data (all of which should have supporting state of design approval) or otherwise as permitted or required by the Sublease;
- (e) have undergone, immediately prior to Return the Redelivery Check. Sublessee shall not utilize fleet sampling as a means to negate a requirement to accomplish structural inspection tasks on the Aircraft;
- (f) have had accomplished all outstanding ADs affecting that model of Aircraft requiring compliance during the Term or within the AD Compliance Period; for this purpose, compliance shall be by terminating action if:
  - 1. Sublessee has complied by terminating action for other aircraft of the same model and series then operated by Sublessee; or
  - 2. the latest date permitted by such AD for required compliance by terminating action falls within the AD Compliance Period.In no event shall there be any time extensions, waivers, deviations or alternative means of compliance with any ADs or other Regulations that are non-transferable by Sublessee.
- (g) have installed all applicable vendor's and manufacturer's service bulletin kits received free of charge by Sublessee that relate to the Aircraft and, to the extent not installed, those kits will be furnished free of charge to Sublessor;
- (h) be in such external livery (freshly painted) as may be requested by Sublessor, such painting to include the fuselage, empennage, wings, pylons, cowlings and flight controls which shall be re-placarded and painted in accordance with standard industry practice, including any required re-balancing of flight controls and required re-weighing or recalculation of the Aircraft or the Aircraft weight;
- (i) have all signs and decals clean, secure and legible;
- (j) meet the requirements of FAR Part 36, Appendix C, Stage 3 noise compliance as in effect at the Delivery Date, without waiver or restriction;
- (k) have no open, deferred, continued, carry over, or placarded maintenance items or watch items and all log book discrepancies shall be cleared;

(l) have had any damage repaired to a permanent repair standard with no additional inspections or other action required in relation to such repairs. If such a repair is not achievable, then the repair shall be to a permanent repair standard, subject to Manufacturer required supplemental inspections but having the highest achievable initial inspection threshold and repeat intervals. If a permanent repair with supplemental inspections has been performed and an inspection would be required to be carried out within [\*\*\*]Cycles after the Return, then immediately prior to the Return, Sublessee shall procure that the inspection is carried out to clear the Aircraft for the maximum time then achievable. If there are repairs to any fatigue critical structure, requiring damage tolerance analysis, one of the following Manufacturer approvals shall be provided:

1. approval providing an initial threshold for inspections and which is valid until that threshold is reached (sometimes termed by an airframe manufacturer as a stage 2 approval) and with a minimum of [\*\*\*] Cycles remaining to that threshold; or
2. approval (which is not time limited) setting out the inspection requirements, including the repeat interval and inspection method (sometimes termed by an airframe manufacturer as a stage 3 approval) with a minimum of [\*\*\*] Cycles remaining until the next such inspection is required.;

The Manufacturer's maintenance manual or the Manufacturer's structural repair manual ("SRM"), as appropriate, will be used to assess any damage and rectification requirements. Any damage outside the scope of the SRM shall require Manufacturer recommendation and FAA 8110-3 or 8100-9 certification or the equivalent certification by the civil aviation authority by the state of design.

- (m) have all its systems serviceable and fully operational for their intended functions in accordance with the Manufacturer's maintenance manual specifications;
- (n) will have no leaks exceeding the limits specified in the Manufacturer's maintenance manual; and
- (o) have Sublessee logos, branding and other identifying marks removed.

### 3. COMPONENTS

- (a) Each Flight Hour and Cycle controlled Hard Time Component (other than the APU, but including the components installed on the APU) shall have not less than the Minimum Component Flight Hours and/or the Minimum Component Cycles (whichever is more restrictive) of life remaining to the next scheduled removal, in accordance with the Maintenance Program or the Manufacturer's Maintenance Planning Document (to the extent that the Maintenance Program does not comply with the Manufacturer's Maintenance Planning Document) and shall be supported by documentation indicating date of installation and by appropriate certification documentation indicating TSO and CSO (if overhaul is the mandatory action required by the Maintenance Program) or TSR/CSR in the form of EASA Form 1 or FAA Form 8130-3 as applicable; for this purpose "Hard Time Component" means any component which has a limited on-wing life in accordance with the Maintenance Program and which can have life fully restored through appropriate maintenance;

- (b) Each calendar-limited component including safety equipment will have not less than its Minimum Component Calendar Life remaining to the next scheduled removal in accordance with the Maintenance Program or the Manufacturer's Maintenance Planning Document (to the extent that the Maintenance Program does not comply with the Manufacturer's Maintenance Planning Document) and shall be supported by documentation indicating date of installation and by appropriate certification documentation indicating date of manufacture (where applicable) and date of overhaul in the form of EASA Form 1 or FAA Form 8130-3 as applicable;
- (c) Each "on-condition" and "condition-monitored" component will be serviceable, and those components installed on the Aircraft within the last [\*\*\*] months shall be supported by documentation indicating date of installation and by appropriate certification documentation such as EASA Form 1 or FAA Form 8130-3;
- (d) The installed components as a group will have an average of total flight time since new of not more than that of the Airframe; and
- (e) Each Airframe Life-Limited Component will have not less than the Minimum Airframe Life-Limited Component Flight Hours and the Minimum Airframe Life-Limited Component Cycles remaining to next expected removal and will be supported by certification documentation necessary to demonstrate accumulated Cycles. The certification shall consist of a Release Certificate from the overhaul agency reflecting the last overhaul with supporting documentation listing part number, serial number, accumulated Cycles and the last operator for each installed Airframe Life-Limited Component; for this purpose, "Airframe-Life Limited Component" means a component with an ultimate life which cannot be restored through appropriate maintenance.

#### 4. ENGINES

- (a) Each Engine will be installed on the Aircraft and will have not less than the Minimum Engine Flight Hours and Minimum Engine Cycles expected life remaining to the next expected removal.  
  
The expected life remaining will be determined by the inspection and checks accomplished by Sublessor in accordance with the Sublease including:
  - (i) full borescope inspection;
  - (ii) analysis of trend data;

- (iii) sea level outside air temperature limit assessment or minimum last [\*\*\*] qualifying flights (excluding the first flight of the day);
  - (iv) maximum power assurance ground runs;
  - (v) technical log analysis for a minimum of the previous [\*\*\*] months of operation;
  - (vi) previous shop visit assessment (if applicable); and
  - (vii) reference to the manufacturer's maintenance manual;
- (b) Following the demonstration flight provided for by Section 18.6 of the Sublease, each Engine shall have just accomplished at the Return Location a complete video borescope inspection of all Engine gas path modules, which inspection shall be performed at Sublessor's expense, and a power assurance run performed at Sublessee's expense in accordance with the Maintenance Program or Manufacturer's maintenance manual and any discrepancies discovered in such inspections which exceed the Engine manufacturer's in-service limits shall be corrected at Sublessee's expense. Sublessee shall cause such borescope inspections to be performed and to be recorded on videotape by an agency selected by Sublessor and shall provide Sublessor with a copy of such videotape on the Return. No Engine shall be on "watch" for any reason requiring any special or out of sequence inspection. Each such Engine shall comply with the operations specification of Sublessee without waiver or exceptions. All items beyond the Engine manufacturer's in-service limits shall be repaired;
- (c) Each Engine Life-Limited Part will have not less than the Minimum Engine LLP Cycles remaining in accordance with the manufacturer's then current limitations for the part number in question, and will be supported by certification documentation necessary to demonstrate Back-To-Birth traceability; for this purpose, "Life Limited Part" means a component with an ultimate life which cannot be restored through appropriate maintenance approved by the state of design of the manufacturer;
- (d) Each Engine will have no less than the Minimum Engine Cycles and the Minimum Engine Flight Hours before any condition or restriction requires any inspection, testing, repair or replacement in accordance with the Engine manufacturer's maintenance manual limits;
- (e) Each Engine will be in a condition to operate at a maximum rated take-off power at sea level under corner point or flat rate conditions and with the Required EGT Margin; and
- (f) Each Engine shall be rated at the Engine Thrust Setting and all Return conditions of this Section 3 are based on such Engine Thrust Setting.

**5. FUSELAGE, WINDOWS AND DOORS**

- (a) The fuselage will be free of dents and abrasions which exceed the limits specified in the Manufacturer's maintenance manual or the SRM;
- (b) Cockpit windows will be free of delamination which exceeds the limits specified in the Manufacturer's maintenance manual or SRM;
- (c) Cabin windows will be substantially free of blemishes and crazing and will be properly sealed;
- (d) Doors will be free moving, correctly rigged and be fitted with serviceable seals; and
- (e) Sublessee will supply a survey or map of the Airframe identifying the specific location of each repair and allowable damage (e.g. dents and scratches) on the Return with a reference to the applicable approved data, accomplishment records and (if applicable) next inspection threshold.

**6. WINGS AND EMPENNAGE**

- (a) Leading edges will be free from damage in excess of the limits specified in the Manufacturer's maintenance manual or SRM; and
- (b) Unpainted surfaces of the wings and empennage will be polished.

**7. INTERIOR AND COCKPIT**

Sublessor may carry out the inspections contemplated by Appendix I (*Cargo Aircraft Interior Standard*). Sublessee shall ensure that any replacements, repairs or repainting required in accordance with Appendix I (as at the Return) are effected at Sublessee's cost. Interior and cockpit to be clean in accordance with airline standards.

**8. LANDING GEAR; WHEELS, TIRES AND BRAKES**

- (a) The Landing Gear and wheel wells will be clean and repaired as necessary;
- (b) Each installed Landing Gear shall have no more Cycles accumulated than the Airframe and, in any event, shall have not less than the Minimum Landing Gear Flight Hours and the Minimum Landing Gear Cycles and the Minimum Landing Gear Calendar Time to the next expected overhaul or removal, as the case may be, in accordance with the then current Manufacturer's Maintenance Planning Document; and

- (c) The tires and brakes will have not less than half of their useful life remaining.

**9. RETURN OF AUXILIARY POWER UNIT (APU)**

The APU shall have just completed a borescope inspection and shall meet all air outputs and temperature limitations under load in accordance with the Maintenance Program and the Manufacturer's maintenance manual, and any discrepancies discovered in such inspection, which exceed the APU manufacturer's in-service limits, shall be corrected at Sublessee's expense. The APU shall have not more than the Minimum APU Limit.

**10. CORROSION**

- (a) The Aircraft shall be in compliance with the Manufacturer's corrosion prevention and control program (CPCP) requirements. All CPCP inspections which would normally be accomplished while access is provided during structural inspection in accordance with the Maintenance Program during the Term shall have been accomplished;
- (b) The entire fuselage will be substantially free from corrosion and will be adequately treated in accordance with Sublessee's corrosion prevention program and the Manufacturer's Maintenance Planning Document; and
- (c) Fuel tanks will be free from contamination and corrosion and a tank treatment program will be in effect during any period of storage.

**11. MAINTENANCE PROGRAM**

- (a) Prior to the Return and upon Sublessor's or Owner Participant's request, Sublessee will provide Sublessor or Owner Participant or its agent reasonable access to the Maintenance Program and the Aircraft Documents in order to facilitate the Aircraft's integration into any subsequent operator's fleet; and
- (b) Upon Return of the Aircraft, Sublessee will, if requested by Sublessor or Owner Participant to do so, provide a certified true current and complete copy of the Maintenance Program to Sublessor or Owner Participant. Sublessor and any person to whom Sublessor grants access to Maintenance Program shall agree that it will not disclose the contents of the Maintenance Program to any other person except to the extent necessary to monitor Sublessee's compliance with the Sublease and/or to bridge the maintenance program for the Aircraft from the Maintenance Program to another program after the Return.

## 12. AIRCRAFT DOCUMENTS

At Return Sublessee will return the following Aircraft Documents to Sublessor. The documents must be in English and current. Any electronic records must be in an industry standard format and accessible without the need for proprietary software, hardware or the payment of any fee. Where records have been customised for Sublessee they must be de-customised ready for Sublessor or the next operator on the Return. If the Maintenance Program is arranged in block events directly in accordance with the maintenance planning document of the type certificate holder, then the status of each block event will be provided. If the Maintenance Program is customised or equalized, then the status of each inspection task must be provided. All summary sheets must be supported with documentation to verify the data in them.

Sublessor accepts that if and to the extent Sublessee does not receive any of the documents set out in this paragraph 12 from Sublessor on Delivery, Sublessee shall not be required to redeliver those documents on the Return, except to the extent that Sublessee has created or is otherwise obliged to create such documents during the Term.

The Aircraft Documents should be collated, ordered and presented for Sublessor's review and acceptance as follows:

### **Aircraft Description**

General description of the Aircraft including manufacturer, type and model, serial number, registration markings, certification basis, installed engine(s) (model & serial number) and APU (model & serial number) with:

- (1) Description of Aircraft's current operational configuration (seat configuration and emergency equipment)
- (2) Details of specific operational capability approvals for which aircraft is equipped or certified (e.g. RVSM, EDTO, IR-OPS, FAR 121 etc.)

### **A. Certificates**

Including:

- (1) Certificate of Airworthiness
- (2) Copy of Air Operator Certificate
- (3) Current Certificate Aircraft Registration
- (4) Certificate of Noise Limitation (or equivalent, AFM page)



- 
- (5) Radio Station License
  - (6) Current maintenance release certificate
  - (7) C of A for export (if applicable)
  - (8) Certificate of sanitary construction (if applicable)
  - (9) Aircraft deregistration confirmation (if applicable)
  - (10) Burn Certificates: confirming compliance with EASA and FAA fire blocking requirements for all seats, backrests, cushions, covers, curtains, floor coverings, carpets, interior surfaces, sidewalls and overhead bins, with “in combination” certification, as applicable.

**B. Log Books**

- (1) Aircraft logbooks
- (2) Engine logbook(s) (if applicable)
- (3) APU logbook (if applicable)

**C. Aircraft Maintenance Status Summaries**

- (1) Certified current Time in Service (Hours & Cycles) and maintenance status
- (2) Certified status of ADs including method of compliance
- (3) Certified status of Manufacturer Service Bulletin incorporated
- (4) Certified status of all Airframe non-Manufacturer modifications incorporated (including STCs)
- (5) Certified status of supplemental structural inspections (SSIs) (if applicable)
- (6) Certified status of CPCP tasks (if applicable)
- (7) Certified status of installed Hard Time Components (including time, hours and cycles remaining)
- (8) Certified status of on condition / condition monitored components
- (9) Certified status of Airframe Check/Inspection history
- (10) Certified list of deferred maintenance items (if applicable)

- (11) status of the maintenance task compliance listing ('Last Done\Next Due') including 'Out of Phase' Inspections. Must demonstrate (at a minimum) compliance with the current Manufacturer's Maintenance Planning Document (MPD). Tasks to be clearly cross referenced (as applicable) for presentation according to the MPD.
- (12) Certified Incident / Accident Clearance Statement for the period since the Delivery Date, covering Airframe, Engines, Landing Gear & APU.
- (13) Certified map of structural repairs & allowable damage, including reference to applicable approved data & time limited items
- (14) Certified status of Certification Maintenance Requirements (CMR)
- (15) Statement of the Aircraft eligible Type Certification
- (16) Life Limited Parts Status, Airframe Parts
- (17) Certified statement of oil and fluid types used in Aircraft, Engines and APU
- (18) Certified installed software listing including part number and revision date
- (19) Certified statement of aircraft operational capability including RVSM, RNP, ETOPS, Landing Category, MNPS, FANS, FM Immunity, 8.33 Spacing, ADS-B
- (20) Certified Flight Data Recorder Report verifying that required parameters are within approved limits
- (21) Operator Maintenance Program Summary
- (22) Aircraft Flight Time Report / Aircraft Log Book
- (23) Certified status of Airworthiness Limitation Items (ALIs)
- (24) Electrical load analysis updated for post production modifications affecting Aircraft's electrics.

**D. Aircraft Maintenance Records**

- (1) Aircraft Technical Logs (minimum of last [\*\*\*] years)
- (2) A Checks - last complete cycle of A Checks (or equivalent)
- (3) C Checks - last complete cycle of C Checks (or equivalent)
- (4) All major airframe structural check packages
- (5) CPCP/ISIP certified maintenance task cards (including level of corrosion found and rectification)
- (6) File for each applicable AD including AD copy, accomplishment instructions (SB) and certified maintenance task cards

- (7) File for each non-mandatory Manufacturer Service Bulletin incorporated including SB copy and certified maintenance task cards
- (8) File for each non-Manufacturer modification incorporated including modification data, substantiation data (including material burn test reports if applicable), regulatory approval and certified maintenance task cards
- (9) Structural repairs, internal and external and allowable damage certified maintenance task cards including repair data and regulatory approval if not within SRM and any instructions for continuing airworthiness.
- (10) Repair map to identify repairs and allowable damage visible from the exterior of the Aircraft and reference to the applicable approved data.
- (11) File for each operational capability compliance inspection including certified maintenance task card if applicable
- (12) Certification Maintenance Requirements (CMR's) certified maintenance task cards
- (13) Certified aircraft weighing report
- (14) Flight control balance status—original manufacturer data or certified maintenance task card (if applicable)
- (15) Last demonstration flight report and relevant technical log
- (16) Supplemental Structural Inspection (SSI) certified maintenance task cards (if applicable)
- (17) Compass Deviation Report including certified task card
- (18) Certified Current Records Inventory (including full inventory of boxes delivered)
- (19) Airworthiness Limitation Items (ALIs) certified maintenance task cards

**E. Configuration Status**

- (1) Layout of Passenger Accommodation (LOPA) drawing, including seat part numbers
- (2) Seats, closets, class dividers, overhead bins, PSU's, cabin crew seating
- (3) Galley drawings & overhaul manuals
- (4) Emergency equipment drawing, with item description and part number
- (5) Loose and galley equipment inventories
- (6) Inventory listing avionic units installed

---

(7) Software Status (cockpit folder)

**F. Aircraft Historical Records**

(1) C of A (export) from state of manufacture

(2) Manufacturer report of ADs incorporated at manufacture

(3) Manufacturer's inspection report, initial equipment list / aircraft readiness log (or equivalent)

(4) Manufacturer's repair/alteration report / SRL

(5) Manufacturer report of service bulletins and optional modifications incorporated at manufacture

(6) Service difficulty reports (if any)

(7) Manufacturer Report of Landing Gear Life Limited Parts installed at manufacture, including part number and serial number

(8) Aircraft Historical / Miscellaneous Log (or equivalent)

(9) Last Flight Data recorder read out & corrections

**G. Engine Records**

Separate hard copy and PDF folders for each Engine, including:

(1) Certified statement of total time in Service (Hours & Cycles)

(2) Certified status of Engine ADs including method of compliance

(3) Certified status of Engine Manufacture Service Bulletins incorporated

(4) Certified status of Engine non-manufacturer modifications including STC's with applicable regulatory approval

(5) Certified Life Limited Parts Listing indicating cycles remaining

(6) Manufacturer Delivery Documents (EDS, Test Data/Performance Summary, Configuration Listing and SB Status at Manufacture)

(7) All historical engine/module shop visit reports

(8) Individual total cycle substantiation data for each life limited part since manufacture and confirmation that each LLP is not incident related

(9) Condition Monitoring Report (Current Trend Data)

- 
- (10) Engine Log Book/Master Records of Installation & Removals
  - (11) Last borescope report (including video / DVD if available)
  - (12) Last Engine Test Cell Report
  - (13) Last On-wing Maximum Power Assurance Ground Run
  - (14) Certified Engine Incident & Accident Clearance Statement
  - (15) ETOPS compliance report and certified maintenance task cards (if applicable)
  - (16) Type of engine oil used
  - (17) Operator certified statement of engine non-exceedance during period of operation
  - (18) Power Rating Operation Statement (Cycles of operation e.g. at 7B24, 7B27, 7B27/B1, etc.)
  - (19) Certified maintenance task cards - Engine Field Repairs since last shop visit (if applicable)
  - (20) Certified maintenance task cards - Long Term Preservation - (if applicable)
  - (21) Certified maintenance task cards - Fan Blade Distribution Sheet
  - (22) Certified maintenance task cards - Last fan blade lubrication
  - (23) Certified maintenance task cards - Engine Mount NDT Inspection (if applicable)
  - (24) Certified engine component configuration listing including line replaceable units
  - (25) Certified high pressure turbine blade listing to include TSN/CSN/TSO/CSO
  - (26) Certified Maintenance task cards for last 'C' Check compliance

**H. APU**

- (1) Certified total time in service (Hours & Cycles) (including statement of ratio from Aircraft hours to APU hours)
- (2) Certified status of APU ADs including method of compliance
- (3) Certified status of APU Manufacturer Service Bulletins incorporated
- (4) APU Log / Master Record of installation & removals
- (5) All historical APU shop visit reports

- (6) Certified Maintenance Status of the APU to include time since last heavy shop visit
- (7) LLP status and certified history of life consumed to date (if applicable)
- (8) Operational performance test certified maintenance task card
- (9) Last Test Cell Report
- (10) ETOPS Compliance Report and certified maintenance task cards (if applicable)
- (11) Last borescope report (including video / DVD if available)

**I. Components**

EASA Form 1 (or equivalent under EASA Part M) or FAA Form 8130-3 for:

- (1) Approved release to service for each Hard Time Component (including last overhaul and any subsequent shop maintenance)
- (2) Approved release to service for each on condition and condition monitored component installed within the previous [\*\*\*] months, or less if accepted by the Aircraft's next state of registry.

**J. Landing Gears**

- (1) EASA Form 1 (or equivalent under EASA Part M) or FAA Form 8130-3 for approved release to service from last overhaul (and any subsequent maintenance) for each major landing gear assembly
- (2) Certified status of life limited parts (LLP's) for each gear showing Cycles consumed since new and allowable Cycles remaining
- (3) Maintenance shop reports from last overhaul and any subsequent shop maintenance
- (4) Certified log card or equivalent for each life limited landing gear part showing details of life consumed and removal/installation history (if applicable) i.e. Back to Birth Traceability
- (5) Work Order / Certified Release to Service (evidence of gear installation on Airframe)

**K. Manuals**

All manuals delivered with the Aircraft under the Sublease updated to the latest revision standard applicable as at the Return. Wiring Diagram Manual, Illustrated Parts Catalogue, Aircraft Maintenance Manual, Aircraft Schematics manual and Wire List & Hook up Charts to be available online line from the Manufacturer or if not, to be on DVD/CD or other media as customary.

**Appendix I**  
**to**  
**Aircraft Sublease Agreement (MSN [●])**

**CARGO AIRCRAFT INTERIOR STANDARD**

The maintenance, repair and component manual requirements of the relevant manufacturer must be complied with at all times in respect of any repairs, replacements or repainting undertaken in the cabin interior of the Aircraft. Any repairs incorporated outside of those already approved in such manuals must have the approval of the relevant manufacturer and regulatory authority prior to the release of the Aircraft from the relevant maintenance facility. Repairs to cabin interior decorative finishes (including seat tables) which do not restore the surface finish to an acceptable standard require replacement of the specific item. FAR / EASA material flammability requirements must always be complied with. References in this Schedule to "Maintenance Manual" are to the Aircraft Maintenance Manual or if an item is not addressed in that manual, then to the relevant manufacturer's maintenance manual.

A. FLIGHT DECK

01	Lining / Instrument Panels	Inspect all flight deck panels and carry out necessary repairs per the Maintenance Manual.
02	Seat Inspection	Detailed visual inspection of flight deck seat structure, harness, fittings, linings, and coverings. Carry out detailed visual inspection of the flight deck seat rails. Carry out a seat operational check in accordance with the Maintenance Manual.
03	Seat Repair	Carry out flight deck seat repairs in accordance with the Component Maintenance Manual. Replace worn seat covers / damaged foams.
04	Seat Painting	Following any required repainting ensure paint condition is to a uniform shading standard.
05	Footrest Anti-Slip Cover Replacement	Renew anti-slip protection on pilot and co-pilot footrests / rudder pedals (as applicable)
06	Floor Covering	Inspect floor covering and replace worn / torn / stained segments.
07	Door Inspection	Detailed visual inspection of the flight deck door. Check for cracks, missing or damaged parts. Check for correct door operation and locking function.
08	Door Repair	Carry out all required repairs per the Maintenance Manual.
09	Flight Deck Area Paint	Inspect the paint condition of: all lining panels, instrument panels, CB panels and door. Following any required repainting ensure paint condition is to a uniform shading standard.

B. ENTRANCE AREAS		
01	Door / Frame Lining Inspection	Detailed visual inspection of door and doorframe linings. Check for cracks, missing or damaged parts. Pay particular attention to the door and door lining pressure seals.
02	Door / Frame Lining Repair	Repair or replace damaged or missing parts per the Maintenance Manual
03	Door / Frame Lining Painting	Inspect paint condition of all lining panels. Following any required repainting ensure paint condition is to a uniform shading standard. Replace damaged placards.
04	Doorframe Structure Painting	Prepare and repaint doorframe structure from all exits.
05	Entrance Area Ceiling Panel Inspection	Detailed visual inspection of entrance area ceiling panels. Check for cracks, missing or damaged parts.
06	Entrance Area Ceiling Panel Repair	Repair or replace damaged or missing parts in accordance with the Maintenance Manual.
07	Entrance Area Ceiling Panel Painting	Inspect paint condition of all ceiling panel outer surfaces. Following any required repainting ensure paint condition is to a uniform shading standard.
08	Entrance Area Floor Coverings	Detailed visual inspection of entrance area floor coverings. Replace damaged, worn and stained segments.
09	Airstairs (if applicable)	Replace worn stairway anti slip material
C. SEATS		
01	Attendant Seats Inspection	Detailed visual inspection of the attendant seats for: structure, structural attachments, lining /fairing panels, foams, dress covers and seatbelts.
02	Attendant and supernumerary seats repair	Carry out required repairs per the Component Maintenance Manual. Replace worn seat covers / damaged foams. Ensure fire blocking labels on cushion and seat backs are present and in good legible condition.



03	Attendant Seats Structure / Lining Panel Painting	Inspect paint condition of seat structure / lining surfaces. Following any repainting ensure paint condition is to a uniform shading standard.
04	Supernumerary Seats Inspection	Detailed visual inspection of the passenger seats for: structure, structural attachments, lining / fairing panels, armrest caps, foams, dress covers, seatbelts, ashtrays and blanking caps (as applicable).
D. GALLEYS & STOWAGE UNITS		
01	Galley Inspection	Detailed visual inspection of galley and stowage compartments for:-  structural integrity, corrosion – particularly of floor attachment fittings (if accessible), contamination, missing or damaged parts.  Perform operational test on all doors, spring flaps, guides, latches and worktop lights per Component Maintenance Manual.
02	Galley Wall Laminate Bulkhead Covering Inspection (As Applicable)	Detailed visual inspection of the galley and stowage compartment laminates and bulkhead covering for cracking, scratches, disbanding, discoloration, stains and torn covers.
03	Galley Repair	Repair or replace damaged or missing parts. All work to be performed per Component Maintenance Manual.
04	Galley Painting	Inspect paint condition of galley surfaces. Following any required repainting ensure paint condition is to a uniform shading standard.
05	Galley Ovens	Carry out deep cleaning of all galley ovens and oven inserts
06	Galley Ovens / Coffee Makers / Water Boilers	Detailed visual inspection of these installations and ensure all units are fully operational per the Maintenance Manual.
07	Galley Floor Coverings	Detailed visual inspection of galley area floor coverings. Replace damaged, worn and stained segments.

E. LAVATORIES

01	Lavatory Inspection	Detailed visual inspection of lavatories for: structural integrity, corrosion – particularly of floor attachment fittings (if accessible), contamination, missing or damaged parts, proper sealing of waste bin compartments. Check doors and waste bin compartment spring flaps for correct operation and locking in, per Component Maintenance Manual.
02	Lavatory – bulkheads and panels	Detailed visual inspection of the lavatory bulkheads and panel coverings for cracking, scratches, disbonding, discoloration, stains and tearing of covering.
03	Lavatory Floor Pan / Floor covering	Detailed visual inspection of the lavatory floor pan / floor covering for satisfactory condition. Replace / repair as applicable.
04	Lavatory Mirrors	Detailed visual inspection of the lavatory mirrors for cracking, scratches, disbanding and discoloration
05	Lavatory Repair	Repair or replace damaged or missing parts in accordance with the Component Maintenance Manual.
06	Lavatory Painting	Following any required repainting ensure paint condition is to a uniform shading standard.
07	Lavatory Lights and Return to Seat Indication	Check all lavatory lights are working. Ensure Return to Seat indication is illuminating properly.
08	Toilet & Washbasin Bowls	Serviceable

F. MISCELLANEOUS

01	Supernumerary Cabin Placards	Inspect all cabin interior placards. Replace all placards that are damaged or with illegible lettering. Ensure that all seat row number decals are correctly positioned on the overhead bin structure.
02	Flight Deck and Supernumerary Cabin Emergency Equipment	Ensure that all; required emergency equipment is located and secured in accordance with the approved Location Chart. required equipment location decals / placards are correctly positioned. ‘Next due date’ labels on Emergency Equipment are clearly legible.

---

**Exhibit F**  
**Price Schedule**

[\*\*]

F-1

**Exhibit G**  
**USPS Provisions**

**A. Ground Services.**

1. **Personnel Screening.** Sun Country Providers will comply with the USPS's personnel screening requirements, in addition to any air carrier or TSA security program requirements, for any Personnel with "access to the mail." Access to the mail refers to ground handling, scanning, transporting, sorting, loading, and unloading mail, and includes supervisory duties in directing these activities. USPS screening requirements include a criminal background check, fingerprinting, drug screening, and US citizenship or documented work authority. Sun Country Provider Personnel will be required to complete various forms and certifications that will be submitted to the Postal Service Security Investigations Service Center for review. Access to the mail will be permitted only after all required checks are completed, except that interim access will be provided pending USPS completion of the criminal history check.

2. **Security.** Sun Country Providers will comply with the USPS requirements with respect to security and segregation of USPS cargo.

3. **Hazardous Materials.** Without limiting their obligations under the Agreement with respect to Hazardous Materials, Sun Country Providers will, as applicable, participate in the completion and submission of information into the *Mail Piece Incident Reporting Tool (MIRT)*, the USPS intranet tool for the collection of information on leaking and other non-mailable items or through completion of Form 1770 – Mail Piece Spill or Leak Incident Report. Any incident which occurs while on board an aircraft will require completion of DOT Form F-5800 (01-2004), *Hazardous Materials Incident Report*, and any other reporting requirements, as applicable.

4. **Electronic Data Interchange (EDI) and Reporting.** Sun Country Providers will use the EDI methods specified by Amazon to transmit and receive volume, tender, possession scan, load scan, and delivery scan information from its system to Amazon and the USPS, as directed by Amazon. In addition, Sun Country Providers will satisfy all requirements relating to the content, timing, and format of any reports or data reasonably required by Amazon to meet the requirements of the USPS Prime Contracts, including daily reports with truck arrival times and unscanned volume (including a detailed reason the cargo wasn't scanned).

5. **Repossession of Mail by USPS.** USPS or Amazon may at any time take possession of, or require Sun Country Providers to return, any or all mail in the possession of a Sun Country Provider.

6. **USPS Customer Address Information.** Sun Country Providers will not use any information or customer information it may obtain from operations concerning the USPS under the Agreement for marketing or any other purposes. Sun Country Providers and any of their Personnel in possession of address information or information concerning USPS customers may not disclose such information to any personnel that do not have a need to know such information and under no circumstances disclose any such information to any personnel involved in marketing activities.

7. USPS Employees Allowed Access. Sun Country Providers will allow escorted USPS employees showing proper credentials access to all buildings, field areas, and ground equipment being used to sort, stage, or transport mail. Sun Country Providers will notify Amazon of all such requests for access as soon as possible. Government regulations (*i.e.* TSA) will supersede this provision.

8. Damages for Delayed, Damaged, Stolen, Lost, or Non-Scanned Mail. Subject to the limitations set forth in Section 8 of the Agreement, Sun Country and the Sun Country Providers will be liable to Amazon for any reduced payments, losses, damages, investigative costs, or other claims asserted by USPS relating to delayed, damaged, stolen, or lost mail, or other performance failures (e.g., untimely performance, failure to obtain required container scans), for which Sun Country Providers or their Personnel are responsible. In the event that Sun Country or a Sun Country Provider disagrees with any reduced payments, losses, damages, investigative costs, or other claims asserted by USPS relating to delayed, damaged, stolen or lost mail or other performance failures, it may challenge the claim in accordance with Section C(1).

B. USPS Standard Clauses. The following requirements arise from the USPS standard terms and conditions. The full text of each clause specified below is incorporated by reference and can be found in the USPS *Supplying Principles and Practices* manual. The brief summary appearing after the clause name is for the convenience of the parties and does not necessarily set out all of its components or requirements. Sun Country will comply, and will cause each of the Sun Country Providers to comply, with each clause to the extent the terms of the clause applies to subcontractors and, in that case, interpreted as modified by the prime contractor-subcontractor relationship.

1. "Privacy Protection (October 2014)," USPS Clause 1-1, requiring, among other things, the protection and non-disclosure of address information and adherence to the USPS Privacy Policy.

2. "Other Contracts (March 2006), USPS Clause B-45, requiring subcontractors to cooperate fully with any other suppliers and Postal Service employees, and carefully fit in its own work as may be directed by the Contracting Officer. Subcontractors must not commit or permit any act that will interfere with the performance of work by any other supplier or by USPS employees.

3. "Protection of the Mail (March 2006), USPS Clause B-77 (Tailored), requiring, among other things, subcontractors to protect and safeguard the mail from loss, theft, or damage while it is in a Sun Country Provider's custody or control and prevent unauthorized persons from having access to the mail.

4. "Equal Opportunity (March 2006)," USPS Clause 9-7, requiring compliance with Executive Order 11246, as amended. Subcontractors agree not to discriminate against any employee or applicant because of race, color, religion, sex, or national origin; to have approved affirmative action plans when 50 or more employees are located in one facility; and to annually submit Standard Form EEO-1.

5. “Service Contract Act (March 2006),” USPS Clause 9-10. Subcontractors agree to pay any employees who are directly engaged in the performance of service under this Agreement, in whole or in part, not less than the hourly wages and fringe benefit required under the applicable Area Wage Determinations issued by the Wage & Hour Division of the U.S. Department of Labor under the Service Contract Act or applicable DOL approved Collective Bargaining Agreement. Subcontractors agree to allow inspection of its records to determine compliance.

6. “Information or Access by Third Parties (March 2006),” USPS Clause B-81. All requests by non-postal individuals (including employees of subcontractors) about mail matter in the custody of a subcontractor or for access to mail in the custody of a subcontractor or Amazon must be referred to the contracting officer or his or her designee.

7. “Access by Officials (March 2006),” USPS Clause B-82 (Tailored). Subcontractors will deny access to the cargo compartment of a vehicle or aircraft containing mail therein to state or local officials except at a postal facility and in the presence of a postal employee or Postal Inspection Service officer, unless to prevent damage to the aircraft, vehicle or their contents. If authorized Federal law enforcement seeks access to the cargo compartment of aircraft or vehicles containing mail therein, subcontractors will notify the Postal Inspection Service before permitting access, unless to prevent immediate damage to the aircraft, vehicle or their contents.

8. “Advertising of Contract Awards (February 2013),” USPS Clause B-25. Subcontractors will not refer in its public statements or commercial advertising to the fact that it is performing a subcontract under a USPS contract or imply in any manner that USPS endorses its products.

9. “Use of Former Postal Service Employees (March 2006),” USPS Clause 1-12. Subcontractor must identify any former USPS employees it proposes to be engaged, directly or indirectly, in contract performance. Such individuals may not commence performance without the contracting officer’s prior approval. If the contracting officer does not provide such approval, the supplier must replace the proposed individual former employee with another individual equally qualified to provide the services.

This requirement does not apply to former USPS employees paid on an hourly basis (e.g., drivers, clerks, letter carriers, mail handlers); former USPS employees who supervised such hourly workers; and former USPS employees who last worked for USPS more than three years from the commencement of this contract. Subcontractor will not hire any former USPS employee to be directly engaged in contract performance who it knows has been separated from USPS for cause (e.g., poor performance, personal conduct, etc.).

10. *If the value of this Agreement exceeds \$10,000:*

“Certification of Nonsegregated Facilities” (Provision 4-3, D.3). Subcontractor is required to furnish a Certification of Nonsegregated Facilities as prescribed by the terms of Provision 4-3.

“Affirmative Action for Handicapped Workers (March 2006),” USPS Clause 9-13, requiring, among other things, subcontractors not to discriminate against any employee or applicant because of physical or mental disability; and to have an approved affirmative action plan if applicable.

11. *If the value of this Agreement exceeds \$100,000:*

“Affirmative Action for Disabled Veterans and Veterans of the Vietnam Era, and Other Eligible Veterans (February 2010),” USPS Clause 9-14, requiring, among other things, subcontractors not to discriminate against the individual because the individual is a special disabled veteran, a veteran of the Vietnam era, or other eligible veteran regarding any position for which the employee or applicant for employment is qualified; and to have an approved affirmative action plan if applicable.

12. *If the value of this Agreement exceeds \$1,000,000:*

“Small, Minority, and Woman-owned Business Subcontracting Requirements (February 2018),” USPS Clause 3-1, requiring subcontractors (if subcontractor is not a small business) to have an approved written subcontracting plan that includes goals for utilization of small, minority-owned, and woman-owned business concerns.

C. Disputes.

1. Any controversy, dispute, difference, disagreement, or claim between Amazon and Sun Country or a Sun Country Provider relating to this Agreement that arises from any USPS cause, act, or omission may be processed under the applicable USPS Prime Contract’s “Claims and Disputes” clause. Sun Country and the Sun Country Providers agree to cooperate with Amazon in such process and be bound by the result obtained. Sun Country and the Sun Country Providers will allow a reasonable time for Amazon to consider and forward to them claims and related communications and materials from USPS. Amazon may, at its option, present a Sun Country Provider’s claim as part of its own claim or allow the Sun Country Provider to present its claim to USPS in Amazon’s name when permitted to do so. Amazon may invoke on behalf of a Sun Country Provider, or allow a Sun Country Provider to invoke, the dispute provisions in the applicable USPS Prime Contract, but Amazon is not required to advance or certify a claim when it cannot do so, after diligent investigation, in good faith. Sun Country and each Sun Country Provider, at its own expense, will furnish all documents, statements, witnesses, and other information required by Amazon and will retain and pay legal counsel of its own choosing (but in any event reasonably acceptable to Amazon) and at its sole expense, and will pay or reimburse all reasonable costs incurred by Amazon in connection with the dispute. Payments under this section will be adjusted by a Sun Country Provider’s allocable share of funds recovered and/or paid on account of such claim.

Exhibit H

**Aircraft Delivery Specification & Modifications**

1. Aircraft Specification.

<u>ATA</u>	<u>DESCRIPTION</u>	<u>Sun Country Specification - 800 (Pelican)</u>	<u>Comments</u>
<b>2</b>	<b>GENERAL REQUIREMENTS</b>		
	Low Weather Minimums	CAT IIIa	standard
	Units for AFM, Ops, FQIS, CDS, FMCS	English	standard
	Alternate Forward CG Limits	Yes	standard
<b>3</b>	<b>GENERAL AIRPLANE CRITERIA</b>		
	Weight & Balance Control Loading Manual	Yes	standard
<b>11</b>	<b>PLACARDS AND MARKINGS</b>		
	Interior Placards & Markings		
	Language	English	standard
	Seat Placards	English	standard
	Exterior Markings – AMM 11	English	standard
<b>21</b>	<b>AIR CONDITIONING</b>		
	Cabin Ascent Rate (ft/min)	750	standard
	Cabin Descent Rate (ft/min)	750	standard
	Cabin Temp Indicator	Celsius	standard
	Blow Through Cooling – E8 Rack	Yes if E8 installed	standard
<b>22</b>	<b>AUTOMATIC FLIGHT CONTROL</b>		
	Digital Flight Control System		
	Features:		
	Mode Control Panel (MCP) with Speed and altitude intervention	Yes	standard
	Flight Control Computer	If Honeywell FCC, at least pn 4082499-903	standard
<b>23</b>	<b>COMMUNICATIONS</b>		
	HF System	deactivate—to be further explored; else Collins digital required if HF installed	standard
	SELCAL		standard
	VHF System - Transceiver	Collins 822-1239-151 822-1287-101	standard  standard



	Communication Management Unit (CMU) ACARS	Collins 822-1239-151	standard (SCA to evaluate if other Collins pn deviations are acceptable)
<b>23-31</b>	Control Wheel PTT Switch	Standard 3 Position with detent	standard
<b>23-51</b>	2 Plug Audio Boom Mic Headset/Headphone Jacks	Yes	standard
<b>24</b>	<b>ELECTRICAL POWER</b> Standby Power (Minutes) Dual battery	60 yes	standard standard
<b>28</b>	<b>FUEL</b> Max Fuel Capacity (US Gallons) Measuring Sticks Calibration Conversion Right Wing Refueling Panel Fuel Quantity Indicators	6,875 Standard Non-Dimensional Units (NDU) NDU to Pounds (manual) Yes Yes	standard standard standard standard standard standard
<b>30</b>	<b>Window Heat ON lights</b>	Window Heat ON lights	standard
<b>31</b>	<b>INDICATING/RECORDING SYSTEMS</b> Digital Flight Data Acquisition Unit (New Rule Compliant) ACMS Capability Printer Quick Access Recorder	Teledyne 2233000-816-1 (Minimum) Yes Miltope (ARINC 744) PN no preference (wide format pedestal) Avionca MQAR	standard standard Standard – SCA STC standard - SCA STC
<b>32</b>	<b>LANDING GEAR</b> Service Interphone Connector – External Power Panel Main Gear Wheel Tires Brakes Nose Gear Wheel	Yes Boeing Messier Bugatti C20626000 28-PR, 225 MPH or greater Messier Bugatti C2063300 (carbon) Boeing Messier Bugatti 20637000	standard Standard – SCA SB standard standard standard standard standard - SCA SB
<b>33</b>	<b>LIGHTING</b> Nose Gear Taxi Light	250 Watt or greater	standard

<b>34</b>	<b>NAVIGATION</b>		
	ILS/GPS Multi-Mode Receiver -c/p (VHF/NAV/DME)	Honeywell 69002600-0101	standard - SCA STC
	Weather Radar - Transceiver Antenna	Collins WRT-2100 822-1710-002 or newer	standard standard
	Drive & Control Panel multiscan compatible	Yes	standard
	Predictive Windshear	Yes	standard
	ADIRU HG2050AC11 or higher MAGVAR 2015	Honeywell	standard
	TCAS 7.1	Collins	standard
34-46	Ground Proximity Warning System	965-1690-052 or newer Honeywell	standard
34-53	ATC System Transponder	ACSS	standard - SCA STC
	pn	9008000-10001	standard - SCA STC
	-c/p	Gables p/n G6992-240	standard - SCA STC
34-61	Flight Management Computer System 2 <sup>nd</sup> Computer	GE 176200-0101	standard
	CDU/MCDU	Yes	standard
	FMC-OPC software - if AC have	MCDU - Color	standard
	Alt/Spd intervention SB	see FMC OPC requirement list	software TBD
	Source Select Switch	Yes	standard
<b>35</b>	<b>OXYGEN</b>		
	Crew Oxygen Cylinder (CuFt)	115 Cu. Ft.	standard
	Flight Crew System – Automatic Pressure Breathing	Yes	standard
	Flight Crew Mask	Full face in flight deck required - Scott p/n MF20-003	standard
	Supernumerary Smoke Goggles	Boeing standard	standard
<b>38</b>	<b>WATER/WASTE</b>		
	No Waste Quantity Gauge	yes	standard
46	EFB	Collins TIMS and AID	standard - equipment is carrier provided; AMZ to make mod slot available
<b>49</b>	<b>APU</b>	Honeywell S351A401-201	
<b>52</b>	<b>DOORS</b>	No	standard
	Forward Airstairs	No	standard

72	<b>ENGINE</b> Single Annular Combuster	Basic	standard
	<b>Post acceptance configuration modification</b>	Yes	standard
	Control Wheel Steering (CWS) Reversion	Yes	standard
	In Approach Mode	Yes	standard
	Control Wheel Steering Warning	No	standard
	Airspeed Deviation Warning	Heading Select	standard
	Flight Director Takeoff Mode	need 200/900	standard
	Altitude Alert (ft) Enhanced	Yes - Peaks/Obstacles	standard - wiring mod
	Volume for Altitude Callouts (-000045)	Alt Mode 6 Volume	standard - wiring mod
	Bank Angle Callout (-000048)	Yes	standard - wiring mod
	500 Smart Callout (-000050)	Part of menu 96	standard - wiring mod
	Callouts (-000082)	Callout menu 96	standard
	G/S Capture Before Localizer Capture	Inhibit	standard
	FMC software – U12		standard
	CDS software options block 15		standard
	DFCS options – if Collins FCCs - P11		standard

2. FMC OPC and CDS OPS Values.

Type	Name	Value	Requirement
FMC OPC	High Idle Descent (737-C)	<b>NO</b>	required
FMC OPC	Runway Remaining vs Offset	<b>NO</b>	required
FMC OPC	Runway in Feet vs Meters	<b>NO</b>	required
FMC OPC	Manual Takeoff Speeds	<b>NO</b>	required
FMC OPC	Missed App in Cyan	<b>YES</b>	required
FMC OPC	VNAV ALT	<b>NO</b>	required
FMC OPC	GPS1	<b>YES</b>	required
FMC OPC	GPS2	<b>YES</b>	required

FMC OPC	Direct GPS	<b>YES</b>	required
FMC OPC	Manual RNP	<b>YES</b>	required
FMC OPC	Abeam Waypoints	<b>NO</b>	required
FMC OPC	Alternate Destination	<b>NO</b>	required
FMC OPC	Alt/Spd Intervention	<b>YES</b>	required
FMC OPC	Certified Takeoff Speeds	<b>NO</b>	required
FMC OPC	Plan Fuel	<b>NO</b>	required
FMC OPC	QFE Altitude Reference	<b>NO</b>	required
FMC OPC	CDU Color	<b>YES</b>	required
FMC OPC	Geometric Path Descent	<b>YES</b>	required
FMC OPC	Pilot Defined Co. Routes	<b>NO</b>	required
FMC OPC	Quiet Climb System	<b>NO</b>	required
FMC OPC	Optional (0%) Noise Grad	<b>NO</b>	required
FMC OPC	CIAP/IAN	<b>NO</b>	required
FMC OPC	GLS Procedures	<b>NO</b>	required
FMC OPC	Gross Weight Inhibit	<b>YES</b>	required
FMC OPC	Takeoff Derate Inhibit	<b>NO</b>	required
FMC OPC	Orbit Missions	<b>NO</b>	required
FMC OPC	TACAN1	<b>NO</b>	required
FMC OPC	TACAN2	<b>NO</b>	required
FMC OPC	Manual Position Update	<b>NO</b>	required
FMC OPC	Common VNAV	<b>YES</b>	required
FMC OPC	Speed Propagation	<b>YES</b>	required
FMC OPC	Additional Fix Pages	<b>YES</b>	required
FMC OPC	Default DME Update Off	<b>NO</b>	required
FMC OPC	Intent Data on ACARS	<b>NO</b>	required

FMC OPC	Intent Data on Dedicated	<b>NO</b>	required
CDS OPS	OPC_EF_GPWC_V1_CALLOUT_G	<b>ENABLE</b>	required
CDS OPS	OPC_EF_BKCRS_G	<b>ENABLE</b>	required
CDS OPS	OPC_EF_CHEVRON_AP_G	<b>DISABLE</b>	required
CDS OPS	OPC_EF_COMP_FLASH_G	<b>DISABLE</b>	required
CDS OPS	OPC_EF_DUAL_FMC_INSTALL_G	<b>ENABLE</b>	required
CDS OPS	OPC_EF_BARO_BUG_TRIANG_G	<b>ENABLE</b>	required
CDS OPS	OPC_EF_IVSI_TCAS_RES_AD_G	<b>ENABLE</b>	required
CDS OPS	OPC_EF_LOC_EXP_FD_G	<b>ENABLE</b>	required
CDS OPS	OPC_EF_MAP_HDG_UP_G	<b>DISABLE</b>	required
CDS OPS	OPC_EF_ALT_TAPE_AGL_REF_G	<b>ENABLE</b>	required
CDS OPS	OPC_EF_MACH_GROUNDSPD_G	<b>ENABLE</b>	required
CDS OPS	OPC_EF_MASI_BUG5_100_G	<b>DISABLE</b>	required
CDS OPS	OPC_EF_MASI_BUG5_80_G	<b>ENABLE</b>	required
CDS OPS	OPC_EF_NCD_ILS_FLAG_G	<b>DISABLE</b>	required
CDS OPS	OPC_EF_PFD_ND_FORMAT_G	<b>ENABLE</b>	required
CDS OPS	OPC_EF_POS_DIF_FULL_TIME_G	<b>DISABLE</b>	required
CDS OPS	OPC_EF_POS_DIF_AUTO_DISP_G	<b>DISABLE</b>	required
CDS OPS	OPC_EF_RALT_ALRT1_G	<b>DISABLE</b>	required
CDS OPS	OPC_EF_RALT_ALRT2_G	<b>DISABLE</b>	required
CDS OPS	OPC_EF_RALT_ALRT3_G	<b>DISABLE</b>	required
CDS OPS	OPC_EF_RALT_ANALOG_G	<b>DISABLE</b>	required
CDS OPS	OPC_EF_RALT_DISP_LOW_G	<b>ENABLE</b>	required
CDS OPS	OPC_EF_RANGE_ARCS_G	<b>DISABLE</b>	required
CDS OPS	OPC_EF_RALT_RRNWY_G	<b>DISABLE</b>	required
CDS OPS	OPC_EF_SINGLE_CH_ANN_G	<b>DISABLE</b>	required
CDS OPS	OPC_TO_ALERT_INH_800FT_G	<b>DISABLE</b>	required
CDS OPS	OPC_EF_TCAS_AI_G	<b>ENABLE</b>	required
CDS OPS	OPC_EF_TCAS_RNG_RING_G	<b>DISABLE</b>	required
CDS OPS	OPC_EF_BARO_READOUT_ALRT_G	<b>DISABLE</b>	required
CDS OPS	OPC_ENG_LO_OIL_Q_ALERT	<b>ENABLE</b>	required
CDS OPS	OPC_FUEL_METRIC_UNITS_G	<b>DISABLE</b>	required
CDS OPS	OPC_HI_VIB_ALERT_G	<b>ENABLE</b>	required
CDS OPS	OPC_ENG_XBLD_DISABLE_G	<b>DISABLE</b>	required
CDS OPS	OPC_EF_SPDTAPE_G	<b>DISABLE</b>	required
CDS OPS	OPC_OVER_UNDER_DISP_G	<b>ENABLE</b>	required
CDS OPS	OPC_FULL_TIME_FUEL_FLOW_G	<b>DISABLE</b>	required
CDS OPS	OPC_EF_TCAS_INSTALLED_G	<b>ENABLE</b>	required
CDS OPS	OPC_ENG_METRIC_UNITS_G	<b>DISABLE</b>	required
CDS OPS	OPC_EF_TERR_INSTALLED	<b>ENABLE</b>	required
CDS OPS	OPC_EF_AUTO_DISPLAY	<b>ENABLE</b>	required

CDS OPS	OPC_ENG_AUTO_IGNITION_G	<b>DISABLE</b>	required
CDS OPS	OPC_EF_CDS_FAULT_REV_VID_G	<b>DISABLE</b>	required
CDS OPS	OPC_EF_AOA_G	<b>DISABLE</b>	required
CDS OPS	OPC_COMMON_N1_INDICATION_G	<b>ENABLE</b>	required
CDS OPS	OPC_EF_NAV_DEV_SCALE_G	<b>ENABLE</b>	required
CDS OPS	OPC_EF_HORZ_LINE_HDG_G	<b>DISABLE</b>	required
CDS OPS	OPC_EF_VREF_FLAP_G	<b>ENABLE</b>	required
CDS OPS	OPC_SELECT_COMP_G	<b>ENABLE</b>	required
CDS OPS	OPC_EF_VNAV_SPD_BAND_G	<b>DISABLE</b>	required
CDS OPS	OPC_EF_MDA_EXTEND_G	<b>DISABLE</b>	required
CDS OPS	OPC_5DU_DISPLAY_G	<b>DISABLE</b>	required
CDS OPS	OPC_ENG_OIL_QTY_GALLONS_G	<b>DISABLE</b>	required
CDS OPS	OPC_ENG_OIL_QTY_OU_PERCENT_G	<b>DISABLE</b>	required
CDS OPS	OPC_EF_LNAV_GA_G	<b>ENABLE</b>	required
CDS OPS	OPC_TOTAL_DIGITAL_FUEL_QTY_G	<b>ENABLE</b>	required
CDS OPS	OPC_FUEL_QTY_LOW_LMT_G	<b>DISABLE</b>	required
CDS OPS	OPC_EF_EFSMAP_CRFRQ_DIS_G	<b>DISABLE</b>	required
FMC OPC	ATS Datalink	<b>NO</b>	preferred
FMC OPC	ATS Fixed Outputs	<b>NO</b>	preferred
FMC OPC	ATS MSG on Displays	<b>NO</b>	preferred
FMC OPC	AOC Datalink	<b>YES</b>	preferred
FMC OPC	Message Recall	<b>YES</b>	preferred
FMC OPC	Engine-Out SIDS	<b>YES</b>	preferred
FMC OPC	ADF1	<b>NO</b>	preferred
FMC OPC	ADF2	<b>NO</b>	preferred
FMC OPC	Takeoff Thrust Auto-Select	<b>NO</b>	preferred
FMC OPC	NDB Size	<b>102</b>	preferred
FMC OPC	Oceanic Lat RNP (nm)	<b>12.0</b>	preferred
FMC OPC	Enroute Lat RNP (nm)	<b>2.0</b>	preferred
FMC OPC	Terminal Lat RNP (nm)	<b>1.0</b>	preferred
FMC OPC	Approach Lat RNP (nm)	<b>0.3</b>	preferred
FMC OPC	Oceanic Vert RNP (ft)	<b>400.0</b>	preferred
FMC OPC	Enroute Vert RNP (ft)	<b>400.0</b>	preferred

FMC OPC	Terminal Vert RNP (ft)	<b>400.0</b>	preferred
FMC OPC	Approach Vert RNP (ft)	<b>400.0</b>	preferred
FMC OPC	ATS Timer	<b>5.0</b>	preferred
CDS OPS	OPC_AUX_FUEL_TANK_G	<b>DISABLE</b>	preferred
CDS OPS	OPC_BITE_AT_INSTALL_G	<b>ENABLE</b>	preferred
CDS OPS	OPC_EEC_HIGH_IDLE_OVRD_G	<b>DISABLE</b>	preferred
CDS OPS	OPC_EF_ADF2_INSTALLED_G	<b>DISABLE</b>	preferred
CDS OPS	OPC_EF_MAP_ADF_POINTERS_G	<b>DISABLE</b>	preferred
CDS OPS	OPC_BRAKE_TEMP_DISP_G	<b>DISABLE</b>	preferred
CDS OPS	OPC_FLIGHT_CONT_DISP_G	<b>ENABLE</b>	preferred
CDS OPS	OPC_EF_WXR_BASIC_G	<b>ENABLE</b>	preferred
CDS OPS	OPC_EF_WXR_BENDIX_G	<b>DISABLE</b>	preferred
CDS OPS	OPC_EF_WXR_COLLINS_1_G	<b>DISABLE</b>	preferred
CDS OPS	OPC_EF_WXR_COLLINS_2_G	<b>DISABLE</b>	preferred
CDS OPS	OPC_EF_WXR_COLLINS_3_G	<b>DISABLE</b>	preferred
CDS OPS	OPC_ENG_TO_INH_10MIN_G	<b>DISABLE</b>	preferred
CDS OPS	OPC_EF_ADF1_NOT_INSTALL_G	<b>ENABLE</b>	preferred
CDS OPS	OPC_EF_NO_ADF_ON_RDMI_G	<b>DISABLE</b>	preferred
CDS OPS	OPC_EF_VSD_GATE1_G	<b>ENABLE</b>	preferred
CDS OPS	OPC_EF_VSD_GATE2_G	<b>ENABLE</b>	preferred
CDS OPS	OPC_EF_VSD_MAP_G	<b>ENABLE</b>	preferred
CDS OPS	OPC_FMC_COMM_MESG_G	<b>DISABLE</b>	preferred
CDS OPS	OPC_ATC_CMU_INST_G	<b>DISABLE</b>	preferred
CDS OPS	OPC_EF_WXR_TILT_MODE_G	<b>ENABLE</b>	preferred
CDS OPS	OPC_ACARS_COMM_MSG_G	<b>ENABLE</b>	preferred
CDS OPS	OPC_EF_WINGLET_INSTALL_G	<b>ENABLE</b>	preferred
CDS OPS	OPC_EF_2POSN_TAILSKID_G	<b>DISABLE</b>	preferred
CDS OPS	OPC_EF_WXR_HONEYWELL_2_G	<b>DISABLE</b>	preferred
CDS OPS	OPC_EF_SPEEDBRAKE_WARN	<b>DISABLE</b>	preferred
CDS OPS	OPC_EF_EPDF	<b>DISABLE</b>	preferred
CDS OPS	OPC_EF_PERSP_RUNWAY	<b>DISABLE</b>	preferred
CDS OPS	OPC_EF_BANK_ANGLE_WARN	<b>DISABLE</b>	preferred
CDS OPS	OPC_EF_OVERRUN_AIR	<b>DISABLE</b>	preferred
CDS OPS	OPC_EF_OVERRUN_GND	<b>DISABLE</b>	preferred
CDS OPS	OPC_EF_AP_ROLL_SAT_ALRTS	<b>DISABLE</b>	preferred

### 3. Master Change and Modifications.

[\*\*\*]

**HEADQUARTERS  
FACILITY LEASE AGREEMENT**

Between

MN Airlines, LLC, d/b/a Sun Country Airlines

And

Metropolitan Airports Commission



**Minneapolis-St. Paul International Airport**

**FEBRUARY 2019**



**TABLE OF CONTENTS**

<b>1.</b>	<b>DEFINITIONS</b>	<b>5</b>
<b>2.</b>	<b>LEASED PREMISES</b>	<b>6</b>
	A. <b>Exclusive Ground Area</b>	6
	B. <b>Preferential Use Leased Premises</b>	6
<b>3.</b>	<b>TERM</b>	<b>6</b>
	A. Term	6
	B. Restoration at Termination	7
	C. Holdover Tenant	7
	D. MAC Guaranteed Loan	7
	E. Lease Buyout Right	7
<b>4.</b>	<b>AUTHORIZED USE OF PROPERTY</b>	<b>8</b>
	A. Leased Premises	8
	B. Fueling	8
	C. Aircraft Deicing	9
	D. Maintenance of Other Aircraft	9
	E. Noise	9
	F. Storage	9
<b>5.</b>	<b>FEES AND CHARGES</b>	<b>9</b>
	A. Ground Rent	10
	B. Building Rent	10
	C. Tenant Improvement Rent	10
	D. Additional Rent	10
	E. Revision of Ground Rent	10
	F. Snow Removal, Maintenance and Repair	11
	G. Late Fee	11
	H. Taxes and Other Charges	11
	I. Utilities	11
<b>6.</b>	<b>DILIGENCE BY TENANT</b>	<b>12</b>
<b>7.</b>	<b>LEASEHOLD IMPROVEMENTS/CONSTRUCTION/FINANCING &amp; REIMBURSEMENT</b>	<b>12</b>
	A. Installation/Construction	12
	B. Permits	12
	C. Liens	12
	D. Title to Improvements and Structural Alterations	12
	E. Construction	13
	F. Financing & Reimbursement	14
<b>8.</b>	<b>MAINTENANCE OBLIGATIONS</b>	<b>15</b>
	A. Maintenance by MAC and Tenant	15
	B. Maintenance and Testing of Fire Suppression System	15
	C. Repair and Condition of Leased Premises	16
	D. Roof and HVAC System – Additional Rent	16
	E. Structural	16

<b>9.</b>	<b>DAMAGE TO OR DESTRUCTION OF LEASED PREMISES</b>	<b>16</b>
	A. Repair	16
	B. Casualty Damage	17
	C. Application of Insurance Proceeds	18
	D. Exceptions from Liability	18
<b>10.</b>	<b>ADMINISTRATIVE CHARGES</b>	<b>18</b>
<b>11.</b>	<b>INDEMNIFICATION AND INSURANCE</b>	<b>19</b>
	A. Indemnification	19
	B. Property Insurance on Buildings	19
	C. Insurance	20
<b>12.</b>	<b>ENVIRONMENTAL RESPONSIBILITIES</b>	<b>21</b>
	A. Definitions	21
	B. Indemnification	21
	C. Compliance with Environmental Laws	22
	D. Notification	22
	E. Right to Take Action	22
	F. Right to Investigate	23
	G. Environmental Responsibility	23
	H. Environmental Condition of Existing Building	24
<b>13.</b>	<b>TANKS</b>	<b>24</b>
<b>14.</b>	<b>MAC TO OPERATE AIRPORTS</b>	<b>24</b>
<b>15.</b>	<b>PUBLIC DATA</b>	<b>24</b>
<b>16.</b>	<b>FUTURE LEASES</b>	<b>24</b>
<b>17.</b>	<b>SIGNS</b>	<b>25</b>
<b>18.</b>	<b>COMPLIANCE WITH LAWS</b>	<b>25</b>
	A. Compliance with Laws	25
	B. Notices of Violation	25
<b>19.</b>	<b>SECURITY REQUIREMENTS</b>	<b>25</b>
	A. Airport Security	25
	B. Penalties Assessed by the TSA	26
<b>20.</b>	<b>BANKRUPTCY</b>	<b>26</b>
<b>21.</b>	<b>DEFAULT</b>	<b>26</b>
	A. Events of Default	26
	B. MAC's Rights Upon Default	27
<b>22.</b>	<b>RIGHT OF ENTRY</b>	<b>27</b>
<b>23.</b>	<b>QUIET ENJOYMENT</b>	<b>28</b>
<b>24.</b>	<b>CIVIL RIGHTS &amp; NONDISCRIMINATION</b>	<b>28</b>
<b>25.</b>	<b>GENERAL PROVISIONS</b>	<b>28</b>
	A. Headquarters Covenant	28
	B. Sublease or Assignment	29
	C. Minnesota Law and Jurisdiction	29
	D. Severability	29
	E. Right to Amend	29
	F. Accord and Satisfaction	30
	G. Attorneys' Fees and Costs	30
	H. Relationship of Parties	30

I.	Headings	30
J.	Waiver	30
K.	Condemnation	30
L.	Subordination to Agreements with the U.S. Government	31
M.	Parking	31
N.	Force Majeure	31
O.	Entire Agreement	31
P.	Existing Lease	31
Q.	Notices	31

Exhibit A – Leased Premises

Exhibit B – Maintenance Responsibility Matrix

Exhibit C – Aircraft Deicing Field Rule

Exhibit D – Project Description (Test Fit Plan and Construction Schedule)

Exhibit E – Civil Rights & Nondiscrimination

**METROPOLITAN AIRPORTS COMMISSION  
HEADQUARTERS FACILITY LEASE AGREEMENT**

This Agreement (“Agreement” or “Lease”) date for reference purposes as the 19<sup>th</sup> day of February, 2019, by and between the Metropolitan Airports Commission, a public corporation of the State of Minnesota (“MAC”) and MN Airlines, LLC d/b/a Sun Country Airlines (“Tenant” or “Sun Country”). MAC and Tenant may hereinafter be referred to as a “Party” or collectively as the “Parties.”

WHEREAS, MAC owns and operates Minneapolis-St. Paul International Airport (“Airport”);

WHEREAS, Tenant has a need for facility space to accommodate its headquarters function; and

WHEREAS, MAC and Tenant have entered into an Airline Operating Agreement and Terminal Building Lease for Minneapolis-St. Paul International Airport dated January 1, 2019, as defined below (“Airline Agreement”).

NOW, THEREFORE, in consideration of the foregoing and mutual promises and covenants set forth, the Parties hereby agree as follows:

**1. DEFINITIONS**

- A. Affiliate or Affiliated Airline. Any “Affiliated Airline” as defined in the Airline Agreement, of Sun Country.
- B. Air Transportation Business. “Air Transportation Business” as defined in the Airline Agreement.
- C. Airline Agreement. Airline Operating Agreement and Terminal Building Lease for Minneapolis-St. Paul International Airport dated January 1, 2019, as the same has been or may be amended, superseded or replaced.
- D. Airport. Minneapolis-St. Paul International Airport.
- E. Executive Director. MAC’s Executive Director/CEO or such other person designated by the Executive Director to exercise functions with respect to the rights and obligations of MAC under this Agreement.
- F. Fixtures. An article used by an airline in the usual course of its Air Transportation Business (such as a trade fixture) that was once personal property, but has been attached to the land or building in a permanent manner so that it is regarded in law as part of the real estate.
- G. MAC. The Metropolitan Airports Commission, which owns and operates Minneapolis-St. Paul International Airport. Where this Agreement speaks of approval or consent by MAC or the commission, such approval or consent means action by MAC’s Executive Director or designated representative.
- H. Preferential Use Aircraft Parking Area. Preferential Use Aircraft Parking Area is designated as preferential use, meaning that Tenant and its Affiliates have the primary right and opportunity to use the Preferential Use Aircraft Parking Area that is part of the Leased Premises under this Agreement. For avoidance of doubt, to the extent Tenant desires to use such area, Tenant shall always have the primary right to do so, even to the extent the exercise of such rights shall requires the movement of other aircraft from the area.
- I. Project. The construction project necessary to remodel the facility to accommodate Sun Country’s headquarters function, as further described in Exhibit D.

- J. TSA. Transportation Security Administration or any successor agency responsible for Airport security.
- K. Vice President of Management & Operations. Person responsible for operation of the Airport or that person’s designated representative.

**2. LEASED PREMISES**

MAC leases to Tenant the premises as shown on the attached Exhibit A, collectively called “Leased Premises”. Such Leased Premises shall be used by Tenant to accommodate the operation of Tenant at the Airport as described herein.

A. **Exclusive Ground Area**

MAC leases to Tenant approximately 365,625 square feet of exclusive use premises as shown on **Exhibit A**, as follows:

Landside Parking Area:	260,897 s.f.
Building Lease Area:	89,543 s.f.
Airside Parking Area:	<u>15,185 s.f.</u>
<b>TOTAL:</b>	<b>365,625 s.f.</b>

B. **Preferential Use Leased Premises**

MAC leases to Tenant, on a Preferential Use basis, the use of approximately 85,795 square feet as shown on **Exhibit A** (“Preferential Use Aircraft Parking Area”). Tenant shall be granted priority to utilize such Preferential Use Aircraft Parking Area, even to the extent the exercise of such rights shall requires the movement of other aircraft from the area. The use of the Preferential Use Aircraft Parking Area by third party airlines is expressly limited to the temporary parking of aircraft on such area, and is subject and subordinate to Tenant’s rights granted herein.

The Preferential Use Aircraft Parking Area shall be used by Tenant for its own aircraft and for aircraft of its Affiliates.

Tenant agrees that such use and assignment of Preferential Use Aircraft Parking Areas shall be consistent with FAA criteria to enable such Preferential Use Aircraft Parking Areas to remain eligible for Federal AIP grant and other funding.

**3. TERM**

A. **Term**

The Term of this Agreement shall be for approximately 10 years commencing February 19, 2019, (the “Effective Date”), and expiring at 11:59 p.m. on February 28, 2029 (“Term”). The Term may be extended for two additional five year terms, by written agreement of both Tenant and MAC. Tenant shall give at least twelve (12) month prior written notice to the other party in each instance where it looks to exercise its extension right. Both parties will make commercially reasonable efforts to come to written agreement to terms within six (6) months from the date of written notice.

B. Restoration at Termination

The parties acknowledge and agree that if Tenant should terminate the Lease prior to the natural expiration of the Lease for any reason, the damages would be impossible or very difficult to accurately estimate, for reasons relating to, but not limited to, the uncertain and fluid nature of the competitive bidding process, both temporally and financially. Thus, the parties agree that upon the early termination of the Lease due to Tenant default or pursuant to Section 3E, Tenant shall pay MAC an additional \$500,000 ("Restoration Fee") to restore the building to its previous condition as an aircraft hangar. In addition, in the event this Agreement is terminated due to a default of Tenant, MAC, subject to the limitations of applicable law, may pursue all available remedies at law or equity including, but not limited to, payment of the remaining Ground Rent, Building Rent, and Tenant Improvement Rent through the remaining Term.

Upon the natural expiration of the Lease Term, Tenant shall be obligated to immediately pay MAC a partial payment of \$250,000 (the "Pre-Payment") towards the actual cost to restore the hangar portion of the Leased Premises to a functional use as it was originally intended for regional jets (the "Restoration Work"), with the remainder of the actual cost incurred (if any) to be paid by Tenant to MAC following MAC's completion of the Restoration Work and delivery to Tenant of final invoices for the work actually undertaken. MAC may authorize a Pre-Payment of less than \$250,000 in its sole and absolute discretion. In the event the actual costs MAC so incurs for the Restoration Work are less than the amount of the Pre-Payment, then MAC shall refund such excess to Tenant following completion of the Restoration Work, which shall be completed within two years after the expiration of the Lease Term.

C. Holdover Tenant

In the event that Tenant shall hold over and remain in possession of the Leased Premises after the expiration of this Agreement without written renewal, any holding over shall not be deemed to operate as a renewal or extension of this Agreement but shall only create a month-to-month tenancy. Either party may terminate upon thirty (30) days written notice. During the Term of any such holding over, Tenant shall remain bound by all terms of this Agreement.

D. MAC Guaranteed Loan

Within three months after the execution of this Agreement, Tenant will endeavor to secure a loan from a third party lender ("Loan"), for which such Loan MAC agrees to provide a guarantee of \$600,000 ("MAC Guarantee") pursuant to a loan agreement and guarantee agreement on reasonable and customary terms that are acceptable to MAC acting reasonably and in all good faith. All proceeds from the Loan will be used in a manner to directly benefit the Premises. In exchange for the MAC Guarantee, Tenant will pay MAC a yearly administrative fee of \$750 as long as the MAC Guarantee is in place. Notwithstanding the foregoing, MAC shall have no obligation to provide the MAC Guarantee if terms conforming to the requirements of this provision are not presented to MAC in proposed final form within the first three months of this Agreement.

E. Lease Buyout Right

Tenant is hereby granted the right and option to terminate this Lease (the "Lease Buyout Right") upon at least ninety (90) days prior written notice to MAC (the "Buyout Notice"), which notice shall specify the "Early Termination Date" (which Early Termination Date must be at least ninety days after the date of MAC's receipt of the Buyout Notice). In the

event Tenant exercises the Lease Buyout Right, then within sixty (60) days after delivery of the Buyout Notice, Tenant shall pay to MAC an amount equal to all Ground Rent, Building Rent, Tenant Improvement Rent, and Restoration Fee that would have accrued after the Early Termination Date through the remaining Term, had this Lease not been terminated pursuant to the Lease Buyout Right (the "Accelerated Rent"). Tenant must also satisfy any and all obligations guaranteed by MAC and satisfy all financed, secured, or other financial obligations that may attach to the Premises or Project. Provided that Tenant timely pays the Accelerated Rent, then this Lease shall terminate on the Early Termination Date as if the same were the natural expiration of the Lease Term.

F. **MAC Termination Option**

In the event that Tenant, for any reason, fails to remain a Signatory Airline, as defined in the Airline Agreement, throughout the Term, then upon such a failure, the sole remedy available to MAC is to terminate this Agreement by providing notice to Tenant of MAC's intent to terminate this Agreement effective not less than one (1) year following such notice to Tenant. This remedy may be exercised within the sole discretion of MAC, and in the event it is so exercised, Tenant shall not have any obligation to pay the Restoration Fee, but Tenant shall pay for the Restoration Work as described in Section 3.B. Failure to by Tenant to remain a Signatory Airline shall not constitute an event of default under this Agreement nor shall failure to remain a Signatory Airline render Tenant liable to MAC for any damages under this Lease.

4. **AUTHORIZED USE OF PROPERTY**

A. **Leased Premises**

The Exclusive Ground Area portion of the Leased Premises shall only be used by Tenant for the uses set forth in this Lease, including, remodeling to convert space throughout the Leased Premises into office and associated support space supporting Sun Country's headquarters operations; vehicular parking; commissary and cargo functions; general office use; airline operations management; maintenance, operation, repair and storage of vehicles and equipment; and employee training functions.

The Preferential Use Leased Premises shall only be used for the fueling and defueling of aircraft; de-icing in permitted areas; aircraft and vehicular parking; commissary and cargo functions; the maintenance, operation, repair and storage of vehicles and equipment; and employee training functions. Tenant may provide routine aircraft servicing and maintenance, as well as emergency aircraft repair or maintenance services on the Preferential Use Leased Premises.

The Leased Premises must be used in furtherance of an aviation business requiring direct access to an airfield or by an airline business. It is expressly understood that the Leased Premises are part of an operating airport grounds, so security of the property is of highest concern. Any operation of the property outside of the normal operation of an airline headquarters that involves more than normal daily traffic flow should be approved by MAC to maintain security. Any use and/or activity not expressly authorized pursuant to this Article requires the prior written approval of MAC.

B. **Fueling**

In its use of the Leased Premises, Tenant may lawfully store fuel in its vehicles, and fuel or defuel its aircraft, ground equipment and vehicles used in Tenant's operation at the Airport, with its own employees or a commercial vendor authorized by MAC to operate at the Airport. Tenant shall not engage in fueling activities other than as specified above. No bulk fuel storage, except propane, is permitted on the Leased Premises.

C. Aircraft Deicing

Tenant shall only de-ice its aircraft in areas of the Airport specifically designated by MAC pursuant to field rule entitled: Aircraft Deicing, dated October 1, 2013, attached as **Exhibit C**, as such may be amended from time to time. Tenant acknowledges that it is aware of and has read and will comply with the Field Rule. MAC shall notify Tenant of all revisions of field rules. Tenant is responsible for being aware of and complying with all current field rules and any revisions thereto as they may occur from time to time whether or not this Agreement is amended to incorporate the revised field rule.

D. Maintenance of Other Aircraft

Tenant may provide routine servicing and maintenance and emergency repair or maintenance services, to other air carrier type aircraft owned, leased or operated by air carriers other than Tenant, provided such services are not provided to hushkitted or widebody aircraft. It is understood that Tenant does not intend to and will not solicit or engage in such maintenance activities for aircraft not otherwise serving the Minneapolis-St. Paul area and that such maintenance activities shall not include major modifications, conversions, remodeling or the maintenance, servicing, handling or hangaring of general aviation or corporate aircraft. Upon written request made no more often than monthly, Tenant will provide MAC with written monthly reports of any maintenance done on air carrier type aircraft owned, leased or operated by air carriers other than Tenant.

E. Noise

Tenant agrees to abide by all current and future Airport noise rules, regulations, and field rules.

At the date this Agreement is executed, Tenant and MAC are parties to an Airline Agreement, which is scheduled to expire December 31, 2023. In the event anytime during the Term of this Agreement Tenant shall either fail to renew such Airline Agreement or for any reason is not be a party to the most current Airline Agreement between MAC and signatory airlines at the Airport, Tenant shall, as a term and condition of this Agreement, comply with all aircraft noise and operational provisions of the then current Airline Agreement although Tenant is not a party to the then current Airline Agreement.

F. Storage

Tenant is authorized to store necessary supplies for maintaining aircraft on the Leased Premises, provided that Tenant meets all environmental and regulatory requirements applicable thereto.

5. **FEES AND CHARGES**

Monthly rental obligations are made up of four essential components: Ground Rent, Building Rent, Tenant Improvement Rent, and Additional Rent, all of which constitute the rental obligations of Tenant and commence as of the Effective Date. Failure to pay any of the four components of rent is a default under the Agreement.



A. Ground Rent

Tenant shall pay the monthly ground rent set forth below in advance on the first day of each month, without demand or invoice, subject to Article 5 .E.

<u>LEASE AREA</u>	<u>AREA</u>	<u>RATE</u>	<u>MONTHLY</u>	<u>ANNUALLY</u>
Exclusive Ground Area	365,625	\$0.28	\$ 8,531.25	\$102,375.00
Preferential Ramp Area	85,795	\$0.28	\$ 2,001.88	\$ 24,022.60
<b>TOTAL:</b>	<b>451,420</b>	<b>\$0.28</b>	<b>\$10,533.13</b>	<b>\$126,397.60</b>

B. Building Rent

Tenant shall pay the monthly building rent set forth below in advance on the first day of each month, without demand or invoice.

<u>DESCRIPTION</u>	<u>AREA</u>	<u>RATE</u>	<u>MONTHLY</u>	<u>ANNUALLY</u>
Building Rent	89,543	\$6.75	\$50,367.94	\$604,415.2

Notwithstanding the foregoing, building rent for the first six months following the Effective Date shall be one-half the monthly amount and equal \$25,183.97 each month.

C. Tenant Improvement Rent

To accommodate remodeling the building to convert it from an aircraft maintenance hangar to an office and support facility capable of accommodating Sun Country Airline's headquarters functions, MAC is making available up to \$5.4 million of tenant improvement dollars to assist with funding the cost of such conversion. MAC and Tenant have agreed to have Tenant repay the \$5.4 million over the course of 114 months, with monthly payments starting as of the first day of the seventh month following the Effective Date as follow:

<u>DESCRIPTION</u>	<u>AMOUNT</u>	<u>INTEREST RATE</u>	<u>MONTHLY</u>	<u>ANNUALLY</u>
TI Rent	\$5,400,000	5.75%	\$61,588.58	\$739,062.97

The Tenant Improvement Rent is subject to adjustment based upon the final amount of tenant improvement dollars MAC actually funds, not to exceed \$5.4 million. In the event this Lease terminates (for a reason other than a default by Tenant or Tenant's exercise of the Lease Buyout Right) prior to the expiration of the aforesaid 114 months, then Tenant's obligation to continue to pay the Tenant Improvement Rent on a monthly basis to MAC through the conclusion of said 114 month period shall cease and not survive the termination of this Agreement.

D. Additional Rent

Additional Rent is as fully set forth in Section S.D. Roof and HVAC system – Additional Rent.

E. Revision of Ground Rent

In conjunction with Ordinance 121 and its revisions any time after January 1, 2021, and no more frequent than every fifth year during the remainder of the Term of the Agreement, MAC reserves the right to amend ground rent upward. Ground rent shall be adjusted downward during the Term in accordance with Ordinance 121 and any revisions thereto. MAC shall rely upon appraisals obtained from one or more qualified, independent

appraisers chosen by MAC. It is understood, consistent with Minnesota Statutes, that any revision or changes in rents shall be reasonable and uniform covering Tenant's lease rights with those charges to other users at the Airport in the same class of users as Tenant.

F. Snow Removal, Maintenance and Repair

MAC shall be responsible for snow removal, routine maintenance, operation, repair and replacement on the Preferential Use Aircraft Parking Area of the Leased Premises and common use taxilanes in accordance with **Exhibit B** (Maintenance Responsibility Matrix). Tenant shall pay the actual costs for MAC performing such snow removal, routine maintenance, operations and repair on the Preferential Use Aircraft Parking Area of the Leased Premises and its pro-rata share of such costs for common use taxilanes/areas as billed by MAC. MAC will use its best efforts to minimize the snow removal costs to Tenant by requiring one half inch of snow accumulation on the ramp prior to calling out the snow removal contractors. At the discretion of MAC's maintenance staff there may be situations or particular snow conditions that will warrant a waiver to this standard in order to maintain Tenant's aircraft operations. Tenant hereby grants to MAC the right to access the Preferential Use Aircraft Parking Area for the purpose of performing snow removal, maintenance, operational activities and repairs as MAC determines appropriate. MAC shall use reasonable efforts not to interfere with Tenant's business operations when performing such obligations. MAC shall provide equipment and labor to fulfill these responsibilities in keeping with Tenant's operational needs in a reasonable manner.

Tenant shall be responsible for the snow removal from all areas of the Leased Premises with the exception of the Preferential Use Aircraft Parking Areas as described above and as further described in Article 8.A.

Notwithstanding the above, Tenant shall be responsible for snow removal on the Preferential Use Aircraft Parking Areas only to the extent that Tenant shall remove snow from such areas that are immediately adjacent to Tenant's building, Tenant's airside building doors, and other appurtenances which cannot be reasonably efficiently reached by routine airfield snow removal equipment utilized by MAC.

G. Late Fee

Any payment not received within thirty (30) days of the due date shall accrue interest at the rate of 1.5 percent per month measured from the due date until paid in full.

H. Taxes and Other Charges

Tenant will pay all taxes, assessments, license fees, or other charges that may be levied or assessed during the Term of this Agreement upon or against any leasehold interests, improvements, or associated equipment on the Leased Premises, or on account of the transacting of business thereon by Tenant, it being understood that Tenant retains the right to contest any taxes so levied or assessed. Taxes levied by reason of occupancy hereunder shall be in addition to rent paid to MAC under this Agreement. Tenant shall obtain and pay for all permits, licenses, or other authorizations required by authority of law in connection with the operation of its business at said Airport.

I. Utilities

Tenant agrees to promptly pay all fees, in addition to its Ground Rent, Building Rent, Tenant Improvement Rent, and Additional Rent hereunder, for all water, sewer, gas, electric, trash removal, and other service facilities supplied to or consumed by Tenant relative to Tenant's operations on the Leased Premises.

**6. DILIGENCE BY TENANT**

Tenant shall have all the rights and privileges to conduct all business operations authorized under the terms of this Agreement, provided, however, that this Agreement shall not be construed in any manner to grant Tenant the exclusive right to provide its services throughout the Airport.

**7. LEASEHOLD IMPROVEMENTS/CONSTRUCTION/FINANCING & REIMBURSEMENT**

**A. Installation/Construction**

Leased Premises shall be delivered to Tenant in its current condition at the time of delivery. All improvements required to accommodate Tenant's operations will be the responsibility of Tenant and must be in compliance with MAC's Design and Construction Standards.

Tenant is responsible for obtaining the necessary building permits for the Project from the MAC Building Official. The MAC Building Official can be reached at 612-467-0426. The cost of installation of the Tenant's equipment and any alterations approved by MAC to the Leased Premises, including electrical, shall be made at Tenant's sole cost and expense. All installations and alterations shall comply with: (1) MAC's Design and Construction Standards as interpreted and administered by the MAC Building Official; and (2) shall be submitted for written review and approval by the MAC Building Official, which approval shall not be unreasonably withheld, conditioned or delayed. No changes or installations shall be made to the Leased Premises without a MAC issued construction permit. Tenant is responsible for all clean-up of construction materials, debris and packaging associated with Tenant's construction or installations.

**B. Permits**

Tenant shall maintain in force and effect all permits, licenses, agreements and similar authorizations required to use the Leased Premises. Tenant's failure to maintain such permits, licenses, agreements and similar authorizations shall not relieve Tenant from the performance of its obligations under this Agreement.

**C. Liens**

Tenant shall: 1) keep the Airport and the Leased Premises free and clear from all liens for labor performed and materials furnished on behalf of Tenant under this Agreement; and 2) defend, at Tenant's cost, each and every lien asserted or filed against the Airport and the Leased Premises or against this Agreement and any improvement on behalf of Tenant on the Leased Premises and pay each and every judgment resulting from such lien to the extent such lien is claimed by, through or under Tenant and is related to Tenant's operations hereunder.

**D. Title to Improvements and Structural Alterations**

All improvements and alterations to the Leased Premises (including the building thereon) that are made by Tenant will be paid for by Tenant and shall become the property of MAC upon the expiration or termination of the Lease. During the Term, all such improvements and alterations to the Leased Premises shall be property of Tenant. All of Tenant's trade fixtures, equipment, and personal property now or hereafter located on the Leased Premises

remain the property of Tenant. Tenant shall within thirty (30) days from the expiration or termination of this Agreement, remove its trade fixtures, equipment, and personal property from the Leased Premises. Any trade fixtures, equipment, and personal property that remains on the Leased Premises after this time shall become the property of MAC.

E. Construction

All construction and remodeling will be completed by Tenant in accordance with MAC Design and Construction Standards, and subject to the following provisions:

1. Tenant shall be responsible for the management, design and construction of the Project. Tenant shall procure all design and construction services through selection by competitive qualification, proposal or bid process with a minimum of three (3) bids or proposals from general contractors. Any changes to the Project scope beyond that set forth in this Agreement shall be approved in advance in writing by the MAC Executive Director. MAC understands that Tenant has not fully completed the Project design and will work in good faith with Tenant to accommodate all reasonable and necessary design changes in order to best meet project timelines.
2. Tenant shall submit for approval by MAC a complete set of construction plans and specifications for the Project (the "Plans"), in accordance with MAC's procedures for approval of tenant work, which may include 45%, 90%, and final submissions. MAC's approval of Tenant's Plans shall not be unreasonably withheld, conditioned, or delayed, and in any event MAC shall provide Tenant with each approval (or disapproval with explanatory comments) of Tenant's Plans at the 45% and 90% point within ten (10) business days after submission by Tenant, and within ten (10) business days after final submission by Tenant. Tenant's submission by email is acceptable so long as it is submitted to a designated representative of MAC. MAC may also provide Tenant with its approval or disapproval by email. Tenant shall obtain all necessary permits/approvals prior to commencement of construction. All bid documents and contracts for construction associated with the Project shall include provisions reasonably acceptable to MAC, including the payment of prevailing wages, use of targeted group businesses, Women's Economic Security Act, Certificate of Compliance, performance and payment bonds, insurance, prompt payment of subcontractors, and maximum allowable retainage.
3. Tenant shall provide MAC a payment and performance bond, each for an amount equal to 100% of the project cost, in a form and with a surety satisfactory to MAC in accordance with Minnesota Statutes Section 574.26. Tenant may fulfill its obligation to provide such payment and performance bonds through such bonds provided by its general contractor, provided MAC must be listed as additional obligee.
4. Prior to commencement of construction, Tenant shall provide MAC evidence of insurance for the work at limits and terms reasonably acceptable to MAC.
5. Tenant shall consult with MAC throughout the construction of the Project and shall permit MAC or its agents access to the Project site at all times upon reasonable prior notice and provided that such access does not unreasonably interfere with such construction activities. Tenant will supply partial electronic "as-built" drawings prior to final payment and final electronic "as-built" drawings within ninety (90) days of Project completion.

F. Financing & Reimbursement

1. MAC will reimburse Tenant for all reasonable and necessary costs (excluding bonding, interest, insurance, furniture, broker fees, and financing costs) incurred by Tenant from third parties in connection with the design and construction of the Project; provided, however, that the reimbursement provided by MAC shall not exceed \$5.4 million. If the cost of the Project exceeds that amount it shall be Tenant's sole responsibility to reduce the Project cost or provide such additional monies needed to fund the remaining portion of the Project. In the event MAC rejects any request for reimbursement submitted by Tenant, whether in whole or in part, MAC shall provide Tenant with a detailed explanation for the reason for such rejection. MAC shall withhold 5% retainage from each reimbursement, which is payable upon approval of final payment.
2. Tenant shall submit any requests for reimbursement on a monthly basis in a format reasonably acceptable to MAC. Tenant shall provide copies of all invoices and all necessary schedule and cost reports for review, including but not limited to consultant or contractor pay requests with all attachments and signed receipts or other proof of payment for expenditures. Tenant shall make no markup for its administrative costs associated with managing the Project.
3. Within forty-five (45) days after receipt of an invoice and supporting documentation, MAC will pay Tenant the amount of the approved invoice, minus any amount for which adequate documentation has not been supplied or which is not otherwise payable by MAC under the terms of this Agreement. In the event MAC rejects any request for reimbursement submitted by Tenant, whether in whole or in part, MAC shall provide Tenant with a detailed explanation for the reason for such rejection.
4. Tenant shall maintain all documents and records associated with the construction of the Project as well as all reports required by MAC pursuant to this Agreement for a period of six ( 6) years and shall permit MAC unrestricted access to all records associated with the Project during Tenant's business hours, Monday through Friday, holidays excepted, with advance notice. MAC reserves the right to audit all Project Costs at its expense at the completion of the Project or at any time within six (6) years thereafter.
5. Tenant shall defend, at its own cost and expense, each and every claim or lien asserted or filed in connection with the Project and pay each and every judgment made or given as a result thereof except, in each case, to the extent caused by or resulting from the MAC's negligence or intentional misconduct. Further, Tenant shall indemnify and hold MAC harmless from and against any and all third party claims (other than those described in Section 7F.I. hereof) incurred by MAC arising out of the negligent design and construction of the Project, including the payment of MAC's reasonable attorney's fees in conjunction with any litigation arising out of or in connection with the design and construction of the Project, except in any of the foregoing circumstances to the extent caused by or resulting from the MAC's negligence or intentional misconduct. MAC shall give notice to Tenant promptly after MAC has actual knowledge of any claim as to which indemnity may be sought hereunder, and shall permit Tenant to assume the defense of any such claim or any litigation resulting therefrom using counsel selected by

Tenant that is reasonably acceptable to MAC with respect to any claims brought against MAC. MAC may participate in such defense at its sole expense; provided, however, that Tenant shall bear the expense of such defense of MAC if representation of both parties by the same counsel would be inappropriate due to actual or potential conflicts of interest (as determined in good faith by MAC's legal counsel). The failure of MAC to give notice as provided herein shall not relieve Tenant of its obligations under this Agreement unless the failure to do so materially prejudices Tenant. Tenant shall not, in the defense of any such claim or litigation for which indemnification by Tenant is required hereunder, except with the consent of the MAC, consent to entry of any judgment or enter into any settlement which does not include as an unconditional term thereof the giving by the claimant or plaintiff to the MAC of a release from all liability in respect to such claim or litigation.

## 8. MAINTENANCE OBLIGATIONS

### A. Maintenance by MAC and Tenant

Tenant will be responsible for providing all maintenance of the Leased Premises as defined in **Exhibit B** and Article 2 except as otherwise provided in this Agreement or shown as a MAC responsibility on **Exhibit B**.

Tenant shall provide all maintenance and snow removal for the MAC constructed access road labeled "site access" on Exhibit A, which connects the Leased Premises to Cargo Road.

For items not specifically identified on Exhibit B, Tenant shall be responsible for maintenance, repair and replacement of the following: 1) other systems and equipment serving the Leased Premises exclusively; 2) alterations to the Leased Premises whether installed by MAC or Tenant; 3) improvements to the Leased Premises whether installed by MAC or Tenant; 4) all other repairs, replacements, renewals and restorations, interior and exterior, ordinary and extraordinary, foreseen and unforeseen; and 5) all other work performed by or on behalf of Tenant pursuant to this Agreement.

Any alterations, improvements or additions performed by MAC to the Leased Premises (i) shall be at MAC's cost, (ii) shall be subject to Tenant's prior written approval, not to be unreasonably withheld, (iii) shall not materially alter the layout or interior improvements Tenant makes to the building, (iv) shall not block Tenant's reasonable access to the building or the Leased Premises, (v) shall not unreasonably effect Tenant's ability to continuously operate its system operations center or its airline headquarters, and (vi) shall be undertaken in a manner to reasonably avoid interfering with the operation of Tenant's business.

### B. Maintenance and Testing of Fire Suppression System

Tenant is required to test the existing fire sprinkler system per NFPA 25 Inspection, Testing and Maintenance of Water Based Fire Protection Systems (the most current edition) and any modifications to the system shall comply with NFPA Standards and MAC Building, Construction, Design and Permitting Standards. Tenant shall have the right to disable the foam component of the fire sprinkler system from operation during the Term, but Tenant shall keep the foam component otherwise in good condition and repair throughout the Term.

C. Repair and Condition of Leased Premises

Tenant at all times at its own costs and expense shall take good care of the Leased Premises and the buildings, structures or improvements located thereon and shall keep and maintain them in safe and good order and repair and in a clean and neat condition, and perform all repair, maintenance, and restoration required thereto during the Term, except as otherwise expressly set forth herein to the contrary. Tenant shall not suffer or permit any waste or nuisance on the Leased Premises or anything thereon that shall interfere with the rights of other airlines or MAC in connection with the use of portions of the Airport not leased to Tenant. At the expiration of the Term of the Agreement or upon any sooner termination thereof, without the necessity or demand therefore by MAC, Tenant shall surrender possession of the Leased Premises peaceably, quietly and in good order and condition, fire, casualty, and reasonably unavoidable causes and reasonable wear and tear excepted.

D. Roof and HV AC System – Additional Rent

Tenant is responsible for the maintenance of the roof and HVAC systems of the building. MAC will replace the roof (the “Roof Cost”) no earlier than January 1, 2024, unless the roof becomes beyond economic repair before 2024 or otherwise is requiring repeated repairs at intervals which indicate that the replacement thereof is commercially reasonable under the circumstances. When the HVAC systems have reached the end of their useful life or otherwise are requiring repeated repairs at intervals which indicate that the replacement thereof is commercially reasonable under the circumstances, MAC will replace HVAC system (the “HVAC Cost”). Enhancements necessary to improve any HVAC systems in the building for the needs of the Project, shall be paid by Tenant, and not serve as a reason to request MAC to replace the HVAC system earlier than necessary.

Following payment of the Roof Cost or the HVAC Cost (each, generically, a “Cost”) by MAC, such Cost shall be amortized on a straight-line basis over a period of fifteen (15) years commencing with the date of such payment, using a reasonable interest rate and Tenant shall repay to MAC, on a monthly basis as Additional Rent, solely the amortized costs applicable to the remainder of the Term of the Lease, including the period of any renewal or other extension of the Lease Term.

E. Structural

Subject to the provisions of Section 9, Tenant is only responsible for any structural issues caused by Tenant including Tenant’s use, and completion of the Project. In the event any repairs, replacements, or maintenance is required to any portion of the structure of the building due to a latent or patent defect therein, MAC shall be solely responsible for undertaking the same at its sole cost.

9. **DAMAGE TO OR DESTRUCTION OF LEASED PREMISES**

A. Repair

(i) All damage or injuries to the Leased Premises and to fixtures, appurtenances, and equipment by: (1) Tenant, moving property in or out of the Leased Premises or by installation, removal of furniture, fixtures, equipment, or other property by Tenant; or (2) resulting from any other cause of any other kind or nature whatsoever due to carelessness, omission, neglect, improper conduct, or other causes of Tenant, or its subtenants, invitees, agents, or employees shall be repaired, restored, or replaced promptly by Tenant. Should the Leased Premises, or any part of them, be damaged as a result of the negligent or willful act or omission of Tenant, or any of its subtenants, invitees, agents, or employees, they shall in all instances, unless approved by MAC, be repaired or replaced by Tenant whether or not such damage is covered by insurance.

(ii) If MAC and/or its employees, or agents damage the Leased Premises through their sole negligence or intentional act, MAC will be solely responsible for the repairs, replacement, or restoration within fifteen (15) days after the occurrence thereof, if such repair, replacement, or restoration is reasonably possible within this time allotment. If MAC fails to repair, replace or restore within such time or as is reasonably possible, then Tenant may make the repairs, replace or restore the damage and render a bill to MAC for all reasonable costs and expenses associated therewith or abate rent until Tenant is made whole.

B. Casualty Damage

(i) All provisions hereof to the contrary notwithstanding, in the event any fire, casualty, or other event renders such damage to the Leased Premises that is reasonably estimated to require more than twelve months from the date of such event to restore the Leased Premises or such damage completely destroys the same (collectively, "Casualty Damage"), and such Casualty Damage was not caused by the negligence or willful misconduct of Tenant or such Casualty Damage is not covered by the insurance required to be maintained by Tenant hereunder, then in that event MAC or Tenant shall have the right to terminate this Lease without payment of any penalty or Accelerated Rent upon notice to MAC or Tenant given within sixty days after the date of such casualty. All property insurance proceeds from Tenant's insurance policy attributable to the building and the leasehold improvements on the Leased Premises shall be paid to MAC, and all such proceeds attributable to Tenant's personal property and equipment shall be paid to Tenant.

(ii) All provisions hereof to the contrary notwithstanding, in the event of Casualty Damage, and such Casualty Damage is caused by the negligence or willful misconduct of Tenant or any of its subtenants, invitees, agents, or employees, then in that event MAC shall have the right to terminate this Lease upon notice to Tenant given within sixty days after the date of such casualty. All property insurance proceeds from Tenant's insurance policy attributable to the building and the leasehold improvements on the Leased Premises shall be paid to MAC, and all such proceeds attributable to Tenant's personal property and equipment shall be paid to Tenant.

(iii) In the event of any Casualty Damage for which Tenant or MAC has not timely exercised its termination right (if any) as aforesaid, Tenant shall proceed to repair and restore the Leased Premises with all due diligence, subject to delays due to force majeure, settling and adjusting the insurance claim, and receipt of insurance proceeds, and the insurance proceeds from Tenant's insurance policy attributable to the leasehold improvements shall be paid to Tenant and held in trust for the repair of the Leased Premises and those proceeds attributable to Tenant's personal property shall be paid to Tenant. MAC shall refund Tenant for its insurance deductible amounts paid pursuant to any Casualty Damage to the proportionate extent such Casualty Damage was caused by the intentional or negligent acts of MAC, or its employees, agents or contractors. Tenant shall collaborate in good faith with MAC in the design, development, repair, and reconstruction of the Leased Premises hereunder (including but not limited to providing MAC with access to meetings and draft plans and access to Tenant's decision-making) and shall comply with the provisions and procedures set forth in Section 7 of this Lease in the performance of the repair and restoration of the Leased Premises following such Casualty Damage.

(iv) If any Casualty Damage occurs that is not the fault of Tenant, or any of their subtenants, invitees, agents, or employees in any way making the Leased Premises substantially unusable, rent and all other charges shall be abated on a per day pro-rated basis during the time the Leased Premises are substantially unusable. No rent shall abate if damage resulted from any act of Tenant or their subtenants, invitees, agents or employees.



C. Application of Insurance Proceeds

Whenever MAC repairs the damage, proceeds, if any, of Tenant's and MAC's property insurance on the Leased Premises and leasehold improvements shall be applied to the cost of the repairs and replacement of the Leased Premises and leasehold improvements. Tenant is responsible for payment of all repair and replacement costs and expenses exceeding insurance proceeds for all of Tenant's personal property, and for all structural and non-structural portions of the Leased Premises only in the event the damage resulted from Tenant's negligent or intentional act or omission, provided this provision does not waive any claims against Tenant. If MAC is not required to and elects not to repair or replace the Leased Premises, the proceeds of all applicable insurance policies maintained in force by MAC shall be paid over to MAC. Tenant will name MAC as loss payee on all applicable property insurance policies covering the Leased Premises.

D. Exceptions from Liability

Except as set forth herein, MAC shall not be liable or responsible to Tenant for any damage or destruction to Tenant's property from any cause other than its own intentional or negligent acts.

10. ADMINISTRATIVE CHARGES

The failure of Tenant to adhere to MAC's operating standards, specifically signage violations or placement of items or operation of vehicles or equipment in areas or roadways not authorized by MAC may result in inconvenience to the public, facility tenants, and may adversely affect the operation of the Airport, necessitating that MAC take administrative action to assess Tenant's failure and notify Tenant of the need to correct the failure. Quantification of the resulting costs of such administrative action is difficult. The Parties agree that the administrative charges set forth below are reasonable estimates of the actual administrative charges that would be incurred by the MAC for the specified breaches of the foregoing operating standards, and Tenant agrees to pay to MAC such charges in accordance with this section.

The charges required by this section are solely for the administrative costs the parties anticipate MAC will incur in connection with the list of specific violations below; payment does not relieve Tenant of responsibility for physical damage, personal injury, or other harm or damage to MAC or to any other person or entity caused by Tenant, or its employees, agents or contractors.

For non-monetary defaults under this Agreement, MAC in its reasonable discretion may determine if a violation of this Agreement has occurred and may impose the following charges. MAC shall provide written notice of each offense to Tenant. Failure to pay assessment within thirty (30) days of such notice shall constitute default under this Agreement.

The first offense in any category will result in a warning letter. The second offense and any subsequent offense will require Tenant to pay to MAC administrative charges in the amount listed below. Tenant agrees that said amounts are fair compensation to MAC for said costs. MAC in no way waives its rights under this Agreement, such as default and termination, or other remedies as prescribed by law through the imposition of administrative charges.

<b>2nd Offense and Subsequent Offenses</b>	<b>\$500.00</b>
--	-----------------

## 11. INDEMNIFICATION AND INSURANCE

### A. Indemnification

To the fullest extent permitted by law, Tenant does hereby covenant and agree to protect, indemnify, defend and hold completely harmless MAC and its Commissioners, officers, agents and employees (collectively "Indemnitees") from and against any and all liabilities, losses, damages, suits, actions, claims, charges, judgments, settlements, fines or demands of any person arising by reason of injury or death of any person, or damage to any property, or any allegation or claim of such property damage, including all reasonable costs for investigation and defense thereof (including, but not limited to, attorney's fees, investigative fees, court costs and expert fees) of any nature whatsoever arising out of or as a result of Tenant's operation at or about the Leased Premises and the Airport in connection with its operations under this Agreement, or the acts or omissions of Tenant's officers, agents, employees, contractors, subcontractors, licensees or invitees related to Tenant's operations under this Agreement, regardless of where the injury, death or damage may occur; provided, however, the indemnification and defense obligations under this Section shall not apply to the extent the claims arise wholly from the negligent act or omission of an Indemnitee. Notwithstanding the foregoing, Tenant's indemnification obligations with respect to environmental matters shall be governed by Section 12 B of this Agreement.

MAC shall give Tenant reasonable notice of any such claim or action. In indemnifying or defending an Indemnitee, Tenant shall use legal counsel and experts selected by Tenant who are reasonably acceptable to MAC. MAC, at its option and at its sole expense, shall have the right to select its own counsel and experts for the defense of claims. Tenant, at their expense, shall provide to MAC all information, records, statements, photographs, video, or other documents reasonably necessary to defend the parties on any claims.

This provision shall survive expiration or earlier termination of this Agreement. The furnishing of the required insurance hereunder shall not be deemed to limit Tenant's obligations under this Agreement.

As a distinct and separate indemnification obligation, Tenant shall protect, defend, indemnify and hold completely harmless the Indemnitees from any claims or liabilities arising out of Tenant's failure or alleged failure to procure and to keep in force the insurance required as part of this Agreement.

Tenant shall not use or authorize the Leased Premises to be used in any manner that would void Tenant or MAC's insurance or increase the insurance risk. Tenant shall comply with all reasonable requirements imposed by the insurers for MAC and Tenant.

### B. Property Insurance on Buildings

Tenant will keep all buildings, contents and leasehold improvements on the Leased Premises continuously insured via a property insurance policy on a form commonly known as a "special causes of loss" with insurance underwriters licensed or admitted in Minnesota and having an A.M. Best rating, or its equivalent, of at least A-VII acceptable to MAC during the Term of this Agreement, covering fire and other risks of physical loss insurable under such coverage, for an aggregate amount equal to 100 percent of their replacement value. Such policies shall be in a form satisfactory to MAC and name MAC as a loss payee as its interest may appear. The policy or policies shall contain a waiver of subrogation by endorsement or terms and conditions of the policy(s) in favor of MAC. Tenant shall keep evidence of such insurance using the standard ACORD form insurance certificate per Minnesota Statute 60A.39 or a form of certificate or memorandum from the licensed insurance broker per Subd. 5 of this Statute.

To the extent MAC maintains property insurance on the Leased Premises, MAC's coverage (or ability to recover under such coverage) shall be limited to the excess value of any property loss after exhaustion of amounts payable under Tenant's property insurance associated with the loss. For the avoidance of doubt, MAC may grant its insurance carriers with rights of subrogation, specifically including but not limited to instances in which MAC's insurance coverage is in excess of amounts payable under Tenant's policies.

In the event of damage or destruction to any buildings or improvements on the Leased Premises, all insurance proceeds shall be used to repair, rebuild and/or restore the buildings and improvements on the Leased Premises unless otherwise mutually agreed in writing by both MAC and Tenant.

C. Insurance

Tenant shall obtain and maintain with insurance underwriters licensed or admitted in Minnesota and having an A.M. Best rating of at least A-VII or equivalent, acceptable to MAC, a standard policy, or policies for protection from claims against it under worker's compensation acts, claims for damages because of bodily injury including personal injury, sickness or disease or death of any and all employees or of any person other than such employees, and from claims for damages against it because of injury to or destruction of property including loss of use resulting therefrom.

Tenant shall carry with insurance underwriters licensed or admitted in Minnesota and having an A.M. Best rating of at least A-VII or equivalent acceptable to MAC, premises operations liability insurance and aircraft liability insurance, hangarkeepers liability on each aircraft engaged in air carrier activities which is owned, operated or under the care, custody or control by Tenant at the Airport. All such insurance shall be in at least the following amount, shall include MAC as an additional insured by endorsement to the policy or policies or terms and conditions of the policy(s) and shall be in form reasonably acceptable to MAC. Tenant shall keep evidence of such insurance using the standard ACORD form insurance certificate per Minnesota Statute 60A.39 or a form of certificate or memorandum from the licensed insurance broker per Subd. 5 of this Statute. MAC reserves the right and Tenant agrees to commercially reasonable revisions upwards or downwards in the minimum insurance requirements hereinafter set forth either by field rule or ordinance of MAC, provided, however, that any such revision shall be nondiscriminatory. If any of the aforementioned insurance is written on a claims made basis, the tenant warrants that continuous coverage will be maintained, or an extended discovery period will be exercised, for a period of three years from the time this Lease expires.

1. Aviation Liability Policy for Contractual liability, Bodily injury and Property Damage - \$100 million, combined single limit, each occurrence, aggregate where applicable.
2. Owned and Non-Owned Aircraft Bodily Injury and Property Damage Liability including Passenger Liability - \$100 million, combined single limit, each occurrence, aggregate where applicable.
3. Workers' Compensation to statutory limits and employer's liability to at least \$1,000,000 bodily injury by accident, \$1,000,000 policy limit each accident bodily injury by disease, \$1,000,000 each employee. The policy or policies shall contain a waiver of subrogation by endorsement or terms and conditions of the policy(s) in favor of MAC.

4. Hangarkeepers liability - \$20 million, combined single limit, each occurrence, aggregate where applicable.
5. Commercial Automobile Liability, for owned, non-owned, hired, leased and rented vehicles - \$26 million, combined single limit, each occurrence, aggregate where applicable.
6. Environmental Liability - \$1 million, combined single limit, each occurrence, aggregate where applicable

Subject to MAC's approval, Tenant may use self-insurance or alternative insurance which MAC reserves the right to periodically review and to reasonably adjust to meet the requirements of this Agreement.

## 12. ENVIRONMENTAL RESPONSIBILITIES

### A. Definitions

"Environmentally Regulated Substances" means any element, compound, pollutant, contaminant, toxic, or other hazardous substance, material or waste, or any mixture thereof, designated, referenced, regulated or identified pursuant to any applicable Environmental Law.

"Environmental Law" means any common law or duty, case law or ruling, statute, rule, regulation, law, ordinance or code whether local, state or federal, that regulates, creates standards for or imposes liability or standards of conduct concerning any element, compound, pollutant, contaminant, or toxic or hazardous substance material or waste, or any mixture thereof or relates in an way to emissions or releases into the environment or ambient environmental conditions, or conduct affecting such matters.

### B. Indemnification

Tenant hereby indemnifies and agrees to defend, protect and hold harmless, MAC, commission members, its officers, employees or agents, any successor or successors to MAC's interest (collectively "MAC Indemnities") from and against any and all losses, liabilities, fines, charges, damages, injuries, penalties, response costs, or claims of any and every kind whatsoever paid, incurred or asserted against, or threatened to be asserted against, any MAC Indemnitee, relating to or regarding, directly or indirectly, Environmentally Regulated Substances or Environmental Laws arising out of or as a result of Tenant's operations of the Leased Premises, including all related claims or causes of action at common law or in equity which arise from Tenant's operations of the Leased Premises, whether occurring within the Leased Premises and on the Airport, (hereinafter "Environmental Claims"), except to the extent such Environmental Claims arise from the willful misconduct of the MAC Indemnitees; such matters will include without limitation: (i) all consequential damages; (ii) the costs of any investigation, study, removal, response or remedial action, as well as the preparation or implementation of any monitoring, closure or other required plan or response action to the extent required under applicable Environmental Laws or required by the MAC based on requirements under applicable Environmental Laws; and (iii) all reasonable costs and expenses incurred by any MAC Indemnitee in connection with such matters including, but not limited to, reasonable attorney's fees and reasonable fees for professional services or firefighting or pollution

control equipment related to spills, releases or unintended discharges. Tenant further agrees to defend, protect, indemnify and hold harmless any MAC Indemnitee for any such matters arising out of or relating to Sections 12.C. and 12.E. below. Such indemnification and Tenant's obligations hereunder, shall survive cancellation, termination, or expiration of the Term of this Agreement. All provisions hereof to the contrary notwithstanding, Tenant's obligation to defend, indemnify, and hold harmless the MAC Indemnitees hereunder shall not extend to any losses, liabilities, fines, charges, damages, injuries, penalties, response costs, or claims of any kind whatsoever arising out of (i) Environmentally Regulated Substances present on, under, or about the Leased Premises or the Airport as of September 1, 2007, which were not installed, placed, spilled, discharged, or released or released thereon by Tenant or (ii) Environmentally Regulated Substances installed, place, spilled, discharged or released by any third party using the Preferential Use Aircraft Parking Area or other areas of the Leased Premises incident thereto to the third party's use of the Preferential Use Aircraft Parking Area.

C. Compliance with Environmental Laws

Tenant shall keep and maintain and shall conduct its operations of the Leased Premises, including both within the Leased Premises and on the Airport, in full compliance with applicable Environmental Laws. Tenant will further ensure that its employees, agents, and contractors, subcontractors, and any other persons conducting any activities on behalf of Tenant related to the Leased Premises, including both within the Leased Premises and on the Airport, will do so in full compliance with all applicable Environmental Laws. Tenant shall be responsible for and shall obtain in its or an affiliated company's name all necessary government permits or other approvals required by applicable Environmental Laws to conduct the operation of the Leased Premises. Upon request of MAC, Lessee shall provide copies to MAC of any such applications, forms, documents, notifications or certifications.

D. Notification

Tenant shall notify MAC in writing within a reasonable amount of time after learning of any matter that might give rise to an Environmental Claim, or if Tenant obtains knowledge of any release, threatened release, discharge, disposal or emission of any Environmentally Regulated Substance related to the operations of the Leased Premises in, on, under or around the Leased Premises or the Airport which are not in full and complete compliance with all applicable Environmental Laws. Tenant shall promptly follow the notification procedures outlined in the MSP Integrated Spill Response and Coordination Plan ("Integrated Plan") regarding any spills, releases or accidental discharges that occur on the Airport.

E. Right to Take Action

MAC shall have the right, but not the obligation or duty, to join or participate in, including if it so elects as a formal party, any legal or administrative or equitable proceedings or actions initiated by any person or entity in connection with any Environmentally Regulated Substance, Environmental Law, Environmental Claim arising out of Tenant's operations of the Leased Premises, whether occurring within the Leased Premises and on the Airport, or if Tenant is not fulfilling its obligations under Section 12.B. above, and in such case to have its reasonable attorneys' fees and costs incurred in connection therewith paid by Tenant to the extent provided pursuant to Section 12B.

F. Right to Investigate

MAC shall have the right, but not the obligation or duty, anytime from and after the date of this Agreement, upon reasonable advance notice to Tenant, in a non-emergency situation, to investigate, study and test to determine whether Environmentally Regulated Substances related to Tenant's operations of the Leased Premises are located in, on or under the Leased Premises or the Airport, or were emitted or released therefrom, which are not in compliance with applicable Environmental Laws. In conducting such investigation, MAC shall use reasonable efforts to avoid disrupting Tenant's operations in the Leased Premises. Upon the reasonable request of MAC, Tenant shall provide a list of any and all Environmentally Regulated Substances related to Tenant's operations of the Leased Premises which are used in, on or under the Leased Premises or the Airport, certified as true and correct, and specifying how such Environmentally Regulated Substances are used, stored, treated, or disposed.

G. Environmental Responsibility

1. Spill Coordination and Responsibility

Tenant agrees to implement the Integrated Plan. Tenant is obligated to ensure that it has adequate resources to respond to a discharge, including retaining a discharge recovery contractor and providing the necessary equipment to respond to a discharge, in accordance with the Integrated Plan.

Annually, Tenant shall verify to MAC that it is complying with this Section 12.G.1 and the Integrated Plan as detailed in the plan.

If MAC incurs costs related to a spill or other environmental expenses related to Environmentally Regulated Substances as a result of Tenant's operations of the Leased Premises, unless due to the gross negligence of MAC, MAC will bill Tenant for all MAC's actual costs, plus a fifteen percent (15%) administrative fee. Tenant shall pay MAC within thirty (30) days of Tenant's receipt of the invoice. Tenant may then determine which Tenant, Tenant Agent, Tenant Clientele or other party, is responsible for such costs.

2. Minnesota Pollution Control Agency ("MPCA") Permits

If applicable, Tenant agrees to make application to be included on and comply with the MSP NPDES Permit or, if the MAC is in agreement, apply for and comply with an individual stormwater permit issued to Tenant.

Tenant (i) shall only conduct vehicle and aircraft maintenance in accordance with the applicable terms and conditions of the MSP NPDES Permit, and (ii) shall only store waste materials outside in accordance with the applicable terms and conditions of the MSP NPDES permit.

Tenant is prohibited from having any discharges of wash waters with detergents or Environmentally Regulated Substances to stormwater. For products containing Environmentally Regulated Substances (e.g. pavement deicers, rubber removal chemicals, detergents, etc.) that may be exposed to stormwater as part of Tenant's operation on the Leased Premises, Tenant use shall be limited to those products which are approved by the Minnesota Pollution Control Agency (MPCA).

3. Miscellaneous Environmental Operating Conditions

If applicable, Tenant agrees to take steps to implement, maintain and comply with the MPCA approved plans or procedures including the Integrated Spill Plan, Recovered Fuels Plan, Oil/Water Separator Plan, and any required procedures as required by the MPCA AST program or other regulating agreements.

H. Environmental Condition of Existing Building

As of the date of MAC's construction of the building, MAC represents and warrants that to the best of its knowledge and belief, the structural and non structural components of the building on the Leased Premises as well as all other areas of the Leased Premises did not contain any Environmentally Regulated Substances in violation of Environmental Laws.

13. TANKS

Tenant shall own and hold title to any aboveground storage tanks installed at any time by Tenant at the Leased Premises, and shall apply for and obtain any permits required by applicable laws in connection with such tanks. Installation of any underground tanks shall be prohibited, and any installation of any above ground tanks shall require the written approval of MAC, not to be unreasonably withheld, conditioned, or delayed. MAC represents and warrants to the best of its knowledge and belief, that the Leased Premises do not contain any underground storage tanks as of the date MAC constructed the building.

Tenant and MAC acknowledge and agree that any tanks installed on the Leased Premises by Tenant during the Term of this Agreement remain under the ownership and control of Tenant until such tanks are removed from the Leased Premises by Tenant. At the expiration or termination of this Agreement, Tenant is required to remove all tanks from the Leased Premises in accordance with applicable Environmental Laws and provide information to MAC which adequately demonstrates that the tanks have not resulted in environmental contamination to the Leased Premises in violation of applicable Environmental Laws. Should contamination from any tank installed and operated by Tenant be discovered, Tenant shall be required to conduct all remediation or corrective action required to bring the Leased Premises into compliance with applicable Environmental Laws.

14. MAC TO OPERATE AIRPORTS

MAC shall properly maintain, operate, and manage the Airport at all times and in a safe manner not dissimilar to generally accepted good practices for airports of similar size and character. If for any reason beyond the control of MAC (including but not limited to war, strikes, riots, and civil commotion), MAC shall fail to properly maintain, operate and manage the Airport, such failure shall not operate as a breach of this Agreement or render MAC liable in damages. In such case Tenant will be able to cancel this Agreement upon one hundred eighty (180) days written notice and rent will abate during the time of non-use.

15. PUBLIC DATA

The parties agree that this Agreement is subject to the Minnesota Government Data Practices Act.

16. FUTURE LEASES

MAC shall be free in its discretion to rent any other space or concessions on the Airport to any other person, persons, or corporations, and for any purpose that it desires, subject, however, to the provisions of Minn. Stat. § 473.651 and federal law.

**17. SIGNS**

Tenant shall be allowed to erect suitable advertising signs on the Leased Premises to advertise its business at the Airport, subject to the prior written approval of MAC as to the form, type, size, location and method of installation so as to be consistent with the current version at time of design and installation of the following: 1) MAC's Exterior Signage and Promotional Activities Policy, 2) Airport Facility Guidelines for Minneapolis-St. Paul International Airport, and 3) MAC Ordinance 94 (MSP Building Code Ordinance) as amended or changed.

**18. COMPLIANCE WITH LAWS**

A. Compliance with Laws

Tenant, at its sole expense, shall promptly comply with and conform to all applicable present and future laws, ordinances, regulations, and requirements of federal, state, county, and other government bodies of competent jurisdiction that apply to or affect, either directly or indirectly, Tenant's use and occupation of the Leased Premises and its operations and activities under this Agreement, and with any lawful order or direction of any public officer relating thereto. MAC shall have the right to and shall adopt and enforce reasonable rules and regulations with respect to the use of the Airport, Leased Premises, and MAC-owned property and related facilities, which Tenant must observe and obey. Subject to the limitations herein, MAC retains the right, but not the duty, to enter and inspect the Leased Premises to determine if Tenant is complying with applicable laws upon reasonable notice to Tenant.

B. Notices of Violation

Tenant shall notify MAC within five (5) business days (Monday – Friday excluding national holidays) after receipt of any notices of violation of any laws, ordinance, rule, regulation or order specifically concerning the Leased Premises.

**19. SECURITY REQUIREMENTS**

A. Airport Security

All employees, agents, and/or subcontractors of Tenant must meet the requirements of the Airport Police Department with regard to security badging access. All security badging questions must be referred to the Airport Police Department Badging Office at 612-467-0623. All necessary badging shall be Tenant's sole expense.

Tenant agrees to be familiar with the physical layout and general operating conditions at the Airport.

Tenant at its own expense shall abide by all Transportation Security Administration ("TSA") or MAC security requirements, ordinances or security directives, including but not limited to, security badge qualifications, access, display, and use, restrictions on sale of dangerous items and limited security area access abilities.

The security of the airport environment, especially in the sterile area, requires constant vigilance and control by MAC. Pursuant to TSA requirements, MAC is only allowed to permit access to the sterile area to individuals who have a business purpose inside the area. Because of this requirement on MAC, security badges issued to Tenant, Tenant's subcontractors, or independent contractors may be deactivated at the end of the day of termination of the Agreement.



B. Penalties Assessed by the TSA

Tenant understands and agrees that in the event the TSA assesses a civil penalty or fine against MAC for any violation of Transportation Security Regulation or other federal statute as a result of any act or failure to act on the part of Tenant, its subtenants, or subcontractors hereunder, Tenant will reimburse MAC in the amount of the civil penalty assessed plus any costs for defending the civil penalty, including reasonable attorneys' fees. MAC will provide Tenant notice of the allegation, investigation or proposed or actual civil penalty. Failure of Tenant to reimburse MAC within one hundred twenty (120) days of receipt of written notice of the assessed civil penalty shall be an event of default.

**20. BANKRUPTCY**

Adequate assurance of future performance as provided by Section 365 of the Bankruptcy Code as amended, includes, but is not to be limited to:

- A. Adequate assurance of the reliability of the source of all of the rentals, fees, charges, and other consideration due under this Agreement after the assumption or assignment of this Agreement.
- B. Adequate assurance that neither the assumption or assignment of this Agreement nor the exercise of rights hereunder by the party assigning or the assignee will breach any provision in any other agreement to which MAC is bound, any federal or state statute, rule or regulation affecting MAC or the Airport, or any rule, regulation, or ordinance made by MAC.
- C. Adequate assurance that the assumption or assignment of this Agreement will not disrupt the operation of the Airport.
- D. Adequate assurance after the assumption or assignment of this Agreement of payment of rents, fees, charges and other consideration in the form of a deposit, other security, or a bond from a reputable surety, in an amount equal to one year's rent.
- E. Adequate assurance that the Leased Premises will be used to provide the aviation services permitted by this Agreement.

**21. DEFAULT**

A. Events of Default

Any of the following shall constitute a default of this Agreement by Tenant.

- 1. Tenant is in arrears in the payment of rent for a period of fifteen (15) days after written notice of default from MAC.
- 2. Tenant fails to operate the Leased Premises as required under this Agreement, or Tenant fails or neglects to do or perform or observe any of the covenants contained herein on its part to be kept and performed and such failure or neglect shall continue for a period of not less than thirty (30) days after MAC has notified Tenant in writing of Tenant's default hereunder and Tenant has failed for reasons other than those beyond Tenant's control to cure such default within said thirty (30) day period, plus such additional time as is reasonable under the circumstances in the event such default, by its nature, cannot reasonably be cured within said thirty day period and the default under this Lease in no way impacts use of the

airport and its facilities by MAC, its tenants and/or other airport users, provided that Tenant commences such cure within said thirty days and thereafter diligently processes such cure to completion. It is agreed that such thirty (30) day notification period shall not be construed to apply to any default in payment of rent.

3. Tenant shall be declared to be bankrupt or insolvent according to law, or if any assignment of its property shall be made for the benefit of creditors, or Tenant is placed in receivership.
4. Tenant is in default under the any loan or financing relating to the Leased Premises or Project that may result in a lien or encumbrance against the Leased Premises, including any loans in which MAC may have guaranteed.
5. A final, non-appealable judgment is entered against Tenant that (i) remains unsatisfied in excess of the period provided for satisfaction by the order of judgment, and (ii) is in the amount equal to or greater than .14% of operating revenue for the most recently reported fiscal year or \$5,000,000.00, whichever is greater.

**B. MAC's Rights Upon Default**

Subject to Section 21A.6, MAC, or those having an estate in the Leased Premises, may take any of the remedies set forth in the following subsections upon the occurrence of an event of default described in Section 21A above.

1. Immediately, or at any time thereafter, via judicial process including summary eviction proceedings where required, to re-enter into or upon the Leased Premises or any part thereof and take possession of the same fully and absolutely without such re-entry working a forfeiture of the rents or other charges to Tenant for the full Term of this Agreement, and in the event of such re-entry, MAC may proceed for the collection of the rents or other charges to be paid under this Agreement or for properly measured damages; or
2. MAC may, at its election, terminate this Agreement upon written notice in the manner hereinafter provided and via judicial process including summary eviction proceedings where required, re-enter Leased Premises as of its former estate therein, and Tenant covenants in case of such termination to remain responsible to MAC for all loss of rents and expense including reasonable attorneys' fees which MAC has suffered or paid by reason of termination, during the residue of the Term; or
3. MAC shall further have all other rights and remedies including injunctive relief, ejectment or summary proceedings in unlawful detainer, and all such remedies shall be cumulative.
4. No judicial process is needed or required should Tenant abandon the Leased Premises. Further, if Tenant rejects the Agreement as part of a bankruptcy proceeding, no further judicial process is needed for MAC to recover the Leased Premises.

**22. RIGHT OF ENTRY**

MAC, its officers, agents, and employees shall have the right, without limitation but upon reasonable prior notice (except in emergency in which event no notice shall be required) and at

reasonable times, throughout the Term of this Agreement to enter upon the Leased Premises for any lawful purpose, including the purpose of determining whether Tenant is complying with its obligations herein, provided however that in all events except pursuant to an emergency, in consideration of Tenant's security concerns and confidentiality of Tenant's customer information, MAC will undertake such entry only during business hours, and that neither MAC nor its employees, agents, representatives or contractors shall be permitted to enter portions of the building containing confidential business or personnel information except when accompanied by an authorized representative of Tenant.

MAC by its authorized officers, employees, agents, contractors, subcontractors, or other representatives, will have the right (at such times as may be reasonable under the circumstances and with as little interruption of Tenant's operation as is reasonably practicable) to enter the Leased Premises for the following purposes:

- A. To inspect such space to determine whether Tenant has complied and is currently in compliance with the terms and conditions of the Lease.
- B. Upon reasonable notice to perform such maintenance, cleaning, or repair as MAC's Executive Director deems necessary, if Tenant fails to perform its obligations under the agreement, and to recover the reasonable cost of such maintenance, cleaning, or repair from Tenant, which will include a 15% administrative fee.

Such entry by MAC shall not be deemed to excuse Tenant's performance of any promise, term, condition, or covenant required of it by this Agreement, and shall not be deemed to constitute waiver thereof by MAC.

**23. QUIET ENJOYMENT**

So long as Tenant is not in default in their obligations hereunder beyond any applicable period for notice and cure granted hereunder, MAC covenants and agrees that Tenant shall have, hold and enjoy peaceful and uninterrupted possession of all of the Leased Premises and of its rights to in, to, and from the Airport as herein granted.

**24. CIVIL RIGHTS & NONDISCRIMINATION**

In satisfaction of the requirements of the FAA Advisory Circular, the provisions of Exhibit E are included in this Lease. However, the requirements contained within Exhibit E remain subject to the limitations of and notice and cure provisions of Section 21.A.2. MAC agrees that it shall enforce the provisions of Exhibit E against Tenant solely in a manner which is reasonable and non-discriminatory.

**25. GENERAL PROVISIONS**

A. Headquarters Covenant

During the Term of this Lease, and any extensions or holdover periods Sun Country hereby covenants and agrees to maintain its "headquarters" in the metropolitan areas of Minneapolis and Saint Paul within the state of Minnesota. As the sole remedy for breach of this covenant, Building Rent shall become \$828,049.92 annually (\$69,004.16 monthly), commencing with the first day of the particular month in which Sun Country violates the Headquarters Covenant (and, in the event any such violation continues for thirty-six consecutive months, the higher Building Rent will be in effect permanently thereafter through the remaining Term of the lease). MAC's failure to comply with FAA Grant Assurances with regard to the allocation and use of terminal facilities with respect to Sun Country shall relieve Sun Country's obligations under this Headquarters Covenant

The term “headquarters” means the corporate office which constitutes (i) the principal office of Sun Country (or any assignee holding all or substantially all (i.e., ninety-five percent (95%) or more) of the stock or assets of Sun Country) from which its business is conducted, and (ii) the principal office of Sun Country’s or such assignee entity’s CEO, CFO, and majority of its other senior management team members.

B. Sublease or Assignment

Tenant shall not sublease the Leased Premises, or transfer or assign this Lease, (collectively, a “Transfer”) without MAC’s prior written consent, at its sole discretion. This Agreement is binding on all legal representatives, successors or assigns. Consent is subject to payment of all rents and the performance of all covenants, conditions and terms contained in this Agreement by Tenant. It shall not be unreasonable for MAC to disapprove a sublease or assignment of the Leased Premises if the proposed sublease or assignee is not an Air Transportation Business.

Notwithstanding the foregoing, this Section shall not be interpreted to preclude a Transfer of Tenant’s rights and obligations hereunder to any person or entity (a) controlling, controlled by, or under common control with Tenant, or (b) that is Tenant’s successor through purchase, merger, reorganization, conversion, or consolidation, or (c) that acquires all or substantially all of the stock or assets of Tenant (collectively, a “Permitted Transferee”); provided that such Permitted Transferee conducts an Air Transportation Business in the Premises and assumes all rights and obligations hereunder. Written notice of such assumption shall be provided by the Tenant and Permitted Transferee prior to the effective date of such Transfer. It is expressly understood that Tenant intends to convert its corporate structure from that of a limited liability company to that of a corporation after the Execution Date hereof, and MAC has no consent rights thereover.

C. Minnesota Law and Jurisdiction

The laws of the State of Minnesota shall govern this Agreement. Tenant further consents to the personal jurisdiction of and venue in the Minnesota state courts.

D. Severability

If any term, condition, or provision of the Agreement or the application thereof to any person or circumstance shall, to any extent, be held to be invalid or unenforceable, the remainder thereof and the application of such terms, provisions, and conditions to persons or circumstances other than those as to whom it shall be held invalid or unenforceable shall not be affected thereby, and the Agreement and all the terms, provisions, and conditions hereof shall, in all other respects, continue to be effective and to be complied with to the full extent permitted by law.

E. Right to Amend

In the event the FAA, or its successors, or the TSA requires modifications or changes in this Agreement as a condition precedent to the granting of funds for the improvement of the Airport, MAC and Tenant agree to consent to such amendments, modifications, revisions, supplements, or deletions of any of the terms, conditions, or requirements of this Agreement as may be reasonably required to obtain such fund; provided, however, that in no event will Tenant be required, pursuant to this subsection, to agree to an increase in the rent or other charges. Tenant and MAC will consult with each other and negotiate in good faith to avoid Tenant’s use of the Leased Premises being materially affected.

F. Accord and Satisfaction

No payment by Tenant of a lesser amount than the rent or other payments required in this Agreement shall be deemed an accord and satisfaction. MAC shall accept such payment without prejudice to MAC's rights to recover the balance of rent and/or payments due or to pursue any other remedy.

G. Attorneys' Fees and Costs

In the event of any suit or proceeding to enforce the terms of the Agreement, each party shall bear its own attorney's fees and costs.

H. Relationship of Parties

It is understood and agreed that nothing in this Agreement is intended or shall be construed as in any way creating or establishing the relationship of co-partners hereto, or as constituting Tenant as the agent, representative or employee of MAC for any purpose or in any manner whatsoever. Tenant is to be and shall remain an independent Tenant with respect to all services performed under this Agreement.

I. Headings

The headings incorporated in the Agreement are for convenience in reference only and are not a part of the Agreement and do not in any way limited or add to the terms and provisions hereof.

J. Waiver

The waiver of breach by Tenant or MAC of any term of this Agreement must be in writing to be effective, and shall not be deemed a waiver of any subsequent breach of the same term or any other term of this Agreement.

K. Condemnation

If it shall be in the public interest, MAC shall have the power to condemn the property interests created by this Agreement provided that this provision shall not be construed as a waiver by MAC or Tenant of their rights to contest the validity of any such condemnation.

Upon taking by MAC and without limitation to the preceding paragraph, (1) in the event of a taking by MAC of the Agreement or any portion of the Leased Premises or other property of MAC or Tenant, MAC's and Tenant's awards shall be limited solely and exclusively to their relocation expenses and those relating to a permanent taking of their personal property, and (2) in no event shall MAC or Tenant be entitled to any award relating to the value of any expired portion of the Term of this Agreement, the leasehold improvements, any fixture located on or about the Leased Premises, or any loss, damage or diminution of Tenant's business. Tenant hereby waives all provisions of applicable law, which is or may be inconsistent with this section.

L. Subordination to Agreements with the U.S. Government

This Agreement shall be subordinate to the provisions of and requirements of any existing or future agreement between MAC and the United States, relative to the development, operation or maintenance of the Airport.

This Agreement and all provisions hereof shall be subject to whatever right the United States Government now has or in the future may have to acquire affecting the control, operation, regulation and taking over of said Airport or the exclusive or non-exclusive use of the Airport by the United States during the time of war or national emergency.

M. Parking

No parking privileges (on areas of the Airport other than the Leased Premises) are provided as part of this Agreement. All such parking must be coordinated with MAC's Landside Operations Department.

N. Force Majeure

If performance of any of the provisions of this Agreement is rendered impossible or is delayed by reason of strikes, fire, flood, explosion, civil commotion, riot, insurrection, terrorism, or act of God, then such performance shall be excused if impossible, or postponed for the period of such delay, if delayed.

O. Entire Agreement

This represents the entire agreement between the Parties. This Agreement may only be modified if done in writing and executed by both Parties.

P. Existing Lease

Tenant and MAC are parties to that certain Aircraft Hangar Facility Lease Agreement dated October 1, 2012, as amended by First Amendment to Aircraft Hangar Facility Lease Agreement dated May 1, 2015, and Second Amendment to Aircraft Hangar Facility Lease Agreement dated October 1, 2017 (collectively, the "Existing Lease"). Notwithstanding the provisions of Section 3(IV)(B) of the Existing Lease, for the period commencing January 1, 2019, the Hangar Rent shall be computed at the rate of \$59,040.00 per month. As of the Effective Date of this Agreement, the Existing Lease shall be deemed terminated.

Q. Notices

Except, as otherwise specifically provided in this Agreement, all notices, demands, elections, requests, and other communications required or permitted herein (any of which is referred to in this paragraph as a "**Notice**") shall be in writing, and delivered by messenger, overnight mail, or courier. Any Notice given by a party's attorney shall be deemed Notice given by such party, provided that, in the case of outside counsel, such party has reasonably communicated the existence of the attorney's representation of the party to the recipient of the Notice. All such Notices (and copies thereof) shall be deemed to be delivered: (a) if sent by messenger, upon personal delivery to the party to whom the Notice is directed; (b) if sent by United States mail (prepaid certified or registered, return receipt requested, correctly addressed), three (3) Business Days after being so mailed; or (c) if sent by overnight courier, with request for next Business Day delivery, on the next

Business Day after sending; addressed as follows (or to such other address as the parties may specify by fifteen (15) days' advance Notice given pursuant to this Section):

**To MAC:**

Director, Commercial Management & Airline Affairs  
Metropolitan Airports Commission  
6040-28th Avenue South  
Minneapolis, MN 55450  
Fax: (612) 970-9600

**To Sun Country Airlines:**

General Counsel  
Sun Country Airlines  
1300 Corporate Center Curve  
Eagan, MN 55121

[Remainder of Page Intentionally Left Blank. Signature Page to Follow.]

IN WITNESS WHEREOF, the Parties hereto signed and executed this instrument the day and year last below written, but the Lease Term commences as of the Effective Date set forth in Article 3.

Date: February 21, 2019

**METROPOLITAN AIRPORTS COMMISSION**

By: /s/ Eric L. Johnson  
Eric L. Johnson, Director – Commercial  
Management & Airline Affairs

Date: February 19, 2019

**MN AIRLINES, LLC.**

By: /s/ Jude I. Bricker  
Jude I. Bricker, President and CEO

STATE OF MINNESOTA            )  
  ) ss.  
COUNTY OF HENNEPIN        )

The foregoing instrument was acknowledged before me this 21<sup>st</sup> day of February 2019, by Eric L. Johnson, Director - Commercial Management & Airline Affairs of Metropolitan Airports Commission, a Minnesota public corporation, on behalf of the corporation.



/s/ Karen M. Racek  
Notary Public

STATE OF MINNESOTA            )  
  ) ss.  
COUNTY OF DAKOTA         )

This instrument was acknowledged before me on the 19<sup>th</sup> day of February, 2019, by Jude I. Bricker, on behalf, on behalf of MN Airlines, LLC, as its president.

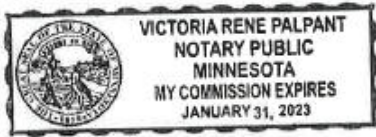

/s/ Victoria Rene Palpant  
Notary Public





**METROPOLITAN AIRPORTS COMMISSION  
Minneapolis-St. Paul International Airport**

**MN Airlines, Inc. dba Sun Country Airlines**

**Maintenance Responsibility Matrix**

	Exclusive Use Space	Non-Exclusive Preferential Use Aircraft Ramp Area	Landside Area
<b><u>Interior Rooms</u></b>			
Custodial Service	Lessee	N/A	N/A
Cleaning, painting, repair & replacement of interior floor covering, walls, wall coverings, ceilings, windows, doors		N/A	N/A
Trash Removal	Lessee	N/A	N/A
Door locks & keys	Lessee	N/A	N/A
Pest Control	Lessee	N/A	N/A
Entrances	Lessee	N/A	N/A
Interior Decorations	Lessee	N/A	N/A
<b><u>Electrical &amp; Lighting</u></b>			
Repair & Replace Fixtures, Ballasts & Bulbs	Lessee	Lessee	Lessee
Repair of outlets & fixtures	Lessee	Lessee	Lessee
Electrical System	Lessee	Lessee	Lessee
<b><u>HVAC</u></b>			
Maint. & repair of internal distribution system	Lessee	N/A	N/A
Conditioned air	Lessee	N/A	N/A
Outlets	Lessee	N/A	N/A
Heating Systems	Lessee	N/A	N/A
Ventilation Systems	Lessee	N/A	N/A
Gas Systems	Lessee	N/A	N/A
Steam Systems	Lessee	N/A	N/A
<b><u>Plumbing &amp; Sewer System</u></b>			
Maintenance & Repair of Internal distribution system	Lessee	N/A	N/A
Maintenance & Repair of Fixtures and Drains	Lessee	N/A	N/A
Water Lines	Lessee	N/A	N/A
Water Equipment	Lessee	N/A	N/A
Sewer Line (including free flow up to common sewer line)	Lessee	Lessee	Lessee
<b><u>Structural &amp; Exterior</u></b>			
Roof	Lessee	N/A	N/A
Exterior Walls	Lessee	N/A	N/A
Foundation	Lessee	N/A	N/A
Floors	Lessee	N/A	N/A
Windows	Lessee	N/A	N/A
Public access doors	Lessee	N/A	N/A
Overhead doors	Lessee	N/A	N/A
Sidewalks	Lessee	N/A	N/A
Ceilings	Lessee	N/A	N/A
Exterior Glass/Windows	Lessee	N/A	N/A
Loading docks	Lessee	N/A	N/A
<b><u>Paved Areas</u></b>			
Crack sealing and repair	Lessee	MAC	Lessee
Striping	Lessee	Lessee	Lessee
Snow Removal	Lessee	MAC	Lessee
Sweeping & Removal of Debris	Lessee	MAC	Lessee
Access Road Snow Removal	Lessee	N/A	Lessee
<b><u>Nonpaved Areas</u></b>			
Landscape Maintenance	Lessee	N/A	Lessee
Erosion and dust control	Lessee	N/A	Lessee
<b><u>Fire Protection Systems</u></b>			
Fire Extinguishers	Lessee	N/A	N/A
Fire Protection Systems	Lessee	N/A	N/A
Sprinkler Systems	Lessee	N/A	N/A
<b><u>Other</u></b>			
Lessee's Trade Fixtures	Lessee	Lessee	N/A
Lessee's Equipment	Lessee	Lessee	N/A
Signs	Lessee	Lessee	Lessee
Ground Power Units	Lessee	N/A	N/A

METROPOLITAN AIRPORTS COMMISSION  
MINNEAPOLIS-SAINT PAUL INTERNATIONAL AIRPORT  
WOLD-CHAMBERLAIN FIELD

October 1, 2013

NOTICE TO: ALL AIRPORT USERS  
FROM: DIRECTOR MSP OPERATIONS  
SUBJECT: FIELD RULE: AIRCRAFT DEICING

The Metropolitan Airports Commission, in consideration of aircraft flight safety during winter operations and to comply with NPDES stormwater permit requirements, is issuing an AIRCRAFT DEICING FIELD RULE.

Aircraft deicing is mandated by Code of Federal Regulations- Federal Aviation Regulations Part 121. Contaminant discharge to receiving waters from MSP is regulated by the Minnesota Pollution Control Agency (MPCA) under National Pollution Discharge Elimination System (NPDES) permit #MN0002101. Per procedures listed in this FIELD RULE, the MAC and its tenants will implement Best Management Practices (BMPs) and best available technologies within aviation safety and operational considerations.

The following rules for aircraft deicing operations are effective this date, [revise date] October 1, 2013

#### LOCATIONS

Aircraft deicing at Minneapolis-Saint Paul International Airport (MSP) will be conducted at locations that fall under one of the following three categories:

1. Dedicated deice pads with associated containment facilities.
2. Apron areas where drainage is controlled by a “plug and pump” system.
3. Non-contained apron areas provided that the tenant makes a provision for the prevention of discharge into the storm drain system (i.e. storm drain covers, MAC approved inserts, etc), augmented by immediate recovery of spent fluids by a Glycol Recovery Vehicle (GRV). These provisions must comply with Chapter 7, Sections 1.14 through 1.24 in the MSP NPDES Permit.

MSP deicing tenants shall utilize the dedicated deicing pads to the extent possible, as required in Chapter 7, Section 1.7 of the MSP NPDES Permit.

#### PROCEDURES

1. MSP tenants shall submit for approval a deicing plan to the MAC Airside Operations Department on an annual basis prior to September 15th. The plan must include deicing procedures for each location category (as described above) that a tenant expects to utilize. Tenants without an approved deicing plan for a specific location category will be prohibited from deicing at that location. THERE WILL BE NO EXCEPTIONS TO THIS PROVISION.
2. Approved methodologies for containment of spent deicing fluids at MSP:
  - Dedicated deicing pads that may be used by all tenants.
  - The current system of plugging and pumping the storm sewers at selected locations will be continued, but not expanded beyond the existing contained gates at the Terminal 1-Lindbergh and Terminal 2-Humphrey aprons.
  - Aircraft deicing may be accomplished on tenant leasehold areas PROVIDED THAT:
    1. All storm sewer inlets likely to receive spent deicing fluids are covered, or equipped by other approved means, to prevent discharge of spent deicing fluid into the storm drain system.
    2. Glycol Recovery Vehicles are used immediately after each aircraft is deiced to recover spent deicing fluids.

3. Recovered product is transported to a dedicated GRV remote holding tank or the MAC Glycol Management Facility for processing.
  4. Deicing operations by tenants do not impact the safety and operations of nearby leaseholders or the general public.
  5. All procedures are conducted in a manner compliant with Chapter 7, Sections 1.14 through 1.24 of the MSP NPDES Permit.
3. Aircraft deicing operations on aircraft movement area surfaces will be strictly limited to areas with containment facilities or where drainage is controlled by a plug and pump system. Glycol dispensing vehicles are authorized to operate on designated movement area surfaces contingent on the requirement that the vehicles are operated by properly trained and licensed personnel, that entry onto a movement area surface is for the express purpose of aircraft deicing, and that prior notification was made to the MAC Airside Operations department. Glycol Recovery Vehicles are not authorized to operate on any open movement area surfaces.
  4. To ensure maximum environmental protection for the storage and use of glycol at MSP, the following fluid management measures are required:
    - Aircraft Deicing Fluid shall not be used for pavement deicing
    - Glycol storage tank(s) including all pipes and valves, will either (i) be within a permanent or portable secondary containment area with the capacity to hold 110% of largest tank volume, or (ii) the storage tanks/tank systems will be double walled, and will incorporate at least one of the following: 1) be constructed with all product fill and removal hoses/pipes on the top of the tank; 2) have breakaway fail-safe valves; 3) have double-walled piping systems; or 4) other similar containment protection as approved by MAC.
    - Filler hoses, unless equipped with end caps or closure valves; must be placed in a contained bucket or in the contained area, when not in use; to reduce leaking from the nozzle.
    - Each glycol tank will be labeled with the type of fluid, the tank capacity and the phone number for MAC Communications (612-726-5577) to facilitate rapid emergency response.
    - If glycol trucks are stored during the non-deicing season with fluid in the tanks, secondary containment measures must be in place.
    - All spills or unintended releases of aircraft deicing fluid must be reported to MAC Communications regardless of whether spill/release occurred in a contained location. Recovery procedures shall be initiated as appropriate.
    - Appropriate best management practices (BMPs) must be implemented for glycol storage and handling by the tank owner and all users. These BMPs shall be documented within their Stormwater Pollution Prevention Plan (SWPPP), as required by the MSP NPDES Permit.
  5. In order to comply with NPDES Permit limits, deicing may be limited or prohibited at any airport location, including tenant leasehold areas. Accordingly, this Field Rule may be modified as necessary due to NPDES Permit requirements, or as necessary for safety or aircraft/airfield operational requirements.

This FIELD RULE contains provisions for safe, efficient aircraft deicing and environmentally responsible containment of spent deicing fluids. It is essential that each company emphasize the need to comply with the FIELD RULE to their employees.

/s/ Phil Burke

---

Phil Burke

Director of MSP Operations

Minneapolis-St. Paul International Airport

**Exhibit E**  
**Civil Rights & Nondiscrimination**

**1. General Civil Rights Provisions**

The Tenant agrees to comply with pertinent statutes, Executive Orders and such rules as are promulgated to ensure that no person shall, on the grounds of race, creed, color, national origin, sex, age, or disability be excluded from participating in any activity conducted with or benefiting from Federal assistance. If the Tenant transfers its obligation to another, the transferee is obligated in the same manner as the Tenant.

This provision obligates the Tenant for the period during which the property is owned, used or possessed by the Tenant and the Airport remains obligated to the Federal Aviation Administration. This provision is in addition to that required by Title VI of the Civil Rights Act of 1964.

**2. Title VI Clauses for Compliance with Nondiscrimination Requirements**

During the performance of this contract, the Tenant, for itself, its assignees and successors in interest (hereinafter referred to as the "Tenant") agrees as follows:

- A. **Compliance with Regulations:** The Tenant will comply with Title VI List of Pertinent Nondiscrimination Acts and Authorities, as they may be amended from time to time, which are herein incorporated by reference and made a part of this contract.
- B. **Nondiscrimination:** The Tenant, with regard to the work performed by it during the contract, shall not discriminate on the grounds of race, color, or national origin in the selection and retention of sub-contractors, including procurement or materials and leases of equipment. The Tenant will not participate directly or indirectly in the discrimination prohibited by the Nondiscrimination Acts and Authorities, including employment practices when the contract covers any activity, project, or program set forth in Appendix B of 49 CFR part 21.
- C. **Solicitations for Subcontracts, including Procurement of Materials and Equipment:** In all solicitations, either by competitive bidding or negotiation made by the Tenant for work to be performed under a subcontract, including procurement of materials, or leases of equipment, each potential sub-contractor or supplier will be notified by the Tenant of the Tenant's obligations under this contract and the Nondiscrimination Acts and Authorities.
- D. **Information and Reports:** The Tenant will provide all information and reports required by the Nondiscrimination Acts and Authorities and will permit access to its books, records, accounts, other sources of information, and its facilities as may be determined by MAC or the Federal Aviation Administration (FAA) to be pertinent to ascertain compliance with such Nondiscrimination Acts and Authorities and instructions. Where any information required of a Tenant is in the exclusive possession of another who fails or refuses to furnish this information, the Tenant will so certify to MAC or the Federal Aviation Administration, as appropriate, and shall set forth what efforts it has made to obtain the information.
- E. **Sanctions for Noncompliance:** In the event of the Tenant's noncompliance with non-discrimination provisions of this contract, MAC shall impose such contract sanctions as it or the Federal Aviation Administration may determine to be appropriate, including, but not limited to:
  - 1. Withholding payments to the Tenant under the contract until the Tenant complies; and/or

2. Cancelling, terminating, or suspending a contract, in whole or in part.

F. **Incorporation of Provisions:** The Tenant will include the provisions of Section 2, subsections A–F in every subcontract, including procurements of materials and leases of equipment, unless exempt by the Nondiscrimination Acts and Authorities. The Tenant will take action with respect to any subcontract or procurement as MAC or the Federal Aviation Administration may direct as a means of enforcing such provisions including sanctions for noncompliance. Provided, that if the Tenant becomes involved in, or is threatened with litigation by a sub-contractor, or supplier because of such direction, the Tenant may request the MAC to enter into any litigation to protect the interests of the MAC. In addition, the Tenant may request the United States to enter into such litigation to protect the interests of the United States.

**3. Title VI Clauses for Transfer of Real Property**

A. The Tenant for himself/herself, his/her heirs, personal representatives, successors in interest, and assigns, as a part of the consideration hereof, does hereby covenant and agree as a covenant running with the land that:

1. In the event facilities are constructed, maintained, or otherwise operated on the property described in this lease for a purpose for which a Federal Aviation Administration activity, facility, or program is extended or for another purpose involving the provision of similar services or benefits, the Tenant will maintain and operate such facilities and services in compliance with all requirements imposed by the Nondiscrimination Acts and Regulations listed in the Pertinent List of Nondiscrimination Authorities (as may be amended) such that no person on the grounds of race, color, or national origin, will be excluded from participation in, denied the benefits of, or be otherwise subjected to discrimination in the use of said facilities.

**4. Title VI Clause for Use of Real Property**

The Tenant for himself/herself, his/her heirs, personal representatives, successors in interest, and assigns, as a part of the consideration hereof, does hereby covenant and agree that: (1) no person on the ground of race, color, or national origin, will be excluded from participation in, denied the benefits of, or be otherwise subjected to discrimination in the use of said facilities, (2) that in the construction of any improvements on, over, or under such land, and the furnishing of services thereon, no person on the ground of race, color, or national origin, will be excluded from participation in, denied the benefits of, or otherwise be subjected to discrimination, (3) that the Tenant will use the premises in compliance with all other requirements imposed by or pursuant to the Nondiscrimination Acts and Authorities.

**5. Title VI List of Pertinent Nondiscrimination Acts and Authorities**

During the performance of this contract, the Tenant, for itself, its assignees, and successors in interest (hereinafter referred to as the “Tenant”) agrees to comply with the following non-discrimination statutes and authorities; including but not limited to:

- Title VI of the Civil Rights Act of 1964 (42 USC § 2000d et seq., 78 stat. 252) (prohibits discrimination on the basis of race, color, national origin);

- 49 CFR part 21 (Non-discrimination in Federally-assisted programs of the Department of Transportation—Effectuation of Title VI of the Civil Rights Act of 1964);
- The Uniform Relocation Assistance and Real Property Acquisition Policies Act of 1970, (42 USC § 4601) (prohibits unfair treatment of persons displaced or whose property has been acquired because of Federal or Federal-aid programs and projects);
- Section 504 of the Rehabilitation Act of 1973 (29 USC § 794 et seq.), as amended (prohibits discrimination on the basis of disability); and 49 CFR part 27;
- The Age Discrimination Act of 1975, as amended (42 USC § 6101 et seq.) (prohibits discrimination on the basis of age);
- Airport and Airway Improvement Act of 1982 (49 USC § 471, Section 47123), as amended (prohibits discrimination based on race, creed, color, national origin, or sex);
- The Civil Rights Restoration Act of 1987 (PL 100-209) (broadened the scope, coverage and applicability of Title VI of the Civil Rights Act of 1964, the Age Discrimination Act of 1975 and Section 504 of the Rehabilitation Act of 1973, by expanding the definition of the terms “programs or activities” to include all of the programs or activities of the Federal-aid recipients, sub-recipients and contractors, whether such programs or activities are Federally funded or not);
- Titles II and III of the Americans with Disabilities Act of 1990, which prohibit discrimination on the basis of disability in the operation of public entities, public and private transportation systems, places of public accommodation, and certain testing entities (42 USC §§ 12131 – 12189) as implemented by U.S. Department of Transportation regulations at 49 CFR parts 37 and 38;
- The Federal Aviation Administration’s Nondiscrimination statute (49 USC § 47123) (prohibits discrimination on the basis of race, color, national origin, and sex);
- Executive Order 12898, Federal Actions to Address Environmental Justice in Minority Populations and Low-Income Populations, which ensures nondiscrimination against minority populations by discouraging programs, policies, and activities with disproportionately high and adverse human health or environmental effects on minority and low-income populations;
- Executive Order 13166, Improving Access to Services for Persons with Limited English Proficiency, and resulting agency guidance, national origin discrimination includes discrimination because of limited English proficiency (LEP). To ensure compliance with Title VI, you must take reasonable steps to ensure that LEP persons have meaningful access to your programs (70 Fed. Reg. at 74087 to 74100);
- Title IX of the Education Amendments of 1972, as amended, which prohibits you from discriminating because of sex in education programs or activities (20 USC 1681 et seq).

## EXECUTION COPY

## AMENDED AND RESTATED CO-BRAND MARKETING AGREEMENT

This Amended and Restated Co-Brand Marketing Agreement (“**Agreement**”), dated as of October 17, 2018 (“**Execution Date**”) is made by and between First National Bank of Omaha, a national banking association with an address of 1620 Dodge Street, Omaha, Nebraska 68197 (“**FNBO**”) and MN Airlines, LLC doing business as Sun Country Airlines, a Minnesota limited liability company with an address of 1300 Corporate Center Curve, Eagan, Minnesota 55121 (“**Co-Brand Partner**”).

## RECITALS:

WHEREAS, FNBO and Co-Brand Partner are parties to that certain Co-Brand Marketing Agreement dated as of July 11, 2013, as amended by that certain Amendment No. 1 to Co-Brand Marketing Agreement dated as of May 1, 2014, that certain Amendment No. 2 to Co-Brand Marketing Agreement dated as of June 3, 2014, that certain Amendment No. 3 to Co-Brand Marketing Agreement dated as of July 1, 2016, that certain Amendment No. 4 to Co-Brand Marketing Agreement dated as of January 10, 2018, that certain Amendment No. 5 to Co-Brand Marketing Agreement dated as of April 2, 2018, and that certain Amendment No. 6 to Co-Brand Marketing Agreement dated as of August 1, 2018 (collectively, the “**Existing Agreement**”).

WHEREAS, FNBO and Co-Brand Partner entered into the Existing Agreement to establish and implement the Program (as defined below) for Co-Brand Partner’s customers; and

WHEREAS, FNBO and Co-Brand Partner desire to amend and restate the Existing Agreement as set forth herein effective as of the Effective Date, except for certain changes to compensation; and

WHEREAS, certain changes to compensation as specified in this Agreement are to be effective as of July 1, 2018.

NOW, THEREFORE, in consideration of the foregoing and the mutual covenants and agreements hereinafter set forth, and for other good and valuable consideration, the receipt and sufficiency of which is hereby acknowledged the foregoing recitals are incorporated in and made a part of this Agreement, and the parties agree to amend and restate the Existing Agreement as follows:

## SECTION 1: DEFINITIONS

For purposes of this Agreement, the parties agree that the capitalized terms set forth below shall have the meanings associated therewith. Definitions in the singular shall be construed to include the plural where appropriate.

“Account” means any consumer credit card account opened and for which Cards are issued to Cardholders pursuant to this Agreement.



“Activated” means a Cardholder has used an Account to make a purchase, cash advance or balance transfer within ninety calendar days from the issuance of the Account. For purposes of clarity, an Account is not considered Activated due to the imposition of an annual fee, whether the fee is assessed or waived.

“Affiliate” means, with respect to an entity, another entity that, directly or indirectly, owns or controls, is owned or controlled by, or is under common ownership or common control with the first entity.

“Alternative Nominated Purchaser” has the meaning given to such term in Schedule 3.7.

“Applicable Law” means any law, regulation or determination of a governmental authority applicable to this Agreement or the duties and obligations of the parties under the Program including consumer protection laws.

“Application Account” means a new Account approved and opened as a result of an application accessed through the Co-Brand Partner Website; a take-one application received through a promotion, on a flight operated by Co-Brand Partner or its Affiliates, or at an airline gate or terminal; or an e-mail application received through an e-mail campaign conducted by FNBO or Co-Brand Partner (with FNBO’s prior express approval).

“Breach” means the unauthorized access to or disclosure of Nonpublic Personal Information, breach of the obligations of Section 7, or any breach of Recipient’s security related to areas, locations or computer systems which contain any Nonpublic Personal Information, including without limitation any instance of theft, unauthorized access by fraud, deception or other malfeasance, or inadvertent access, whether caused by Recipient’s employee, Subcontractor or any third party, in each case related to the Program.

“Card” means any Network consumer credit card issued by FNBO pursuant to this Agreement.

“Cardholder” means a person: (a) to whom an Account is issued pursuant to this Agreement; or (b) authorized to use any Card or Account issued pursuant to this Agreement.

“Cardholder List” means Cardholder names, addresses and other information pertaining to Cardholders or Accounts generated as a result of this Agreement.

“Claims” means any and all proceedings, actions, claims, allegations, suits, damages, losses, costs, charges, fines, expenses or any liabilities of any nature, kind, and description whatsoever (including reasonable attorneys’ fees, court costs and expenses and the cost of enforcing an indemnity provision, which shall be reimbursed as incurred).

“Co-Brand Partner Proprietary Rights” means: (a) Customer Lists; (b) the information on the Co-Brand Partner Website, excluding any FNBO Proprietary Rights; (d) any domain names Co-Brand Partner registers for Co-Brand Partner’s use on the world wide web; (e) Co-Brand Partner Marks; (f) the name of Co-Brand Partner; (g) all materials related to the Rewards Program and all inserts and marketing materials designed by or on behalf of and paid for by Co-Brand Partner, and (g) any and all information, ideas, concepts, artwork, graphics, applications

and any other proprietary rights of Co-Brand Partner used in creating the Co-Brand Partner Website or Rewards Program materials. For the avoidance of doubt, Co-Brand Partner Proprietary Rights do not include any FNBO Marks, the name of FNBO or any information, ideas, concepts, artwork, graphics, applications or other materials developed or paid for by FNBO.

“Co-Brand Partner Website” means the applicable portion of Co-Brand Partner’s website located on the internet at a domain registered, owned and maintained by Co-Brand Partner.

“Compensation” means fees and revenue sharing amounts paid by FNBO to Co-Brand Partner under this Agreement.

“Confidential Information” means any information, including Nonpublic Personal Information, which the Recipient obtains, maintains, processes or otherwise is permitted to access from or about the Discloser, its Affiliates or their respective Consumers. FNBO’s Confidential Information includes, but is not limited to, the Cardholder List and all information contained on applications for Accounts. Co-Brand Partner’s Confidential Information includes, but is not limited to, the Customer Lists.

“Consumer” means an individual, including an individual’s legal representative, who has obtained or applied for a financial product or service from either party or its Affiliates for personal, family or household purposes, or who is identified on a marketing or other list or file made available by one party to the other party.

“Consumer Account” means an Account for a natural person for personal, family or household purposes.

“Contract Year” means the twelve (12) month period of time commencing on July 1, 2018 and each succeeding twelve (12) month period during the Term.

“Control” means, for purposes of the definition of “Affiliate,” possessing, directly or indirectly, the power to direct or cause the direction of the management or affairs of an entity, whether through ownership or voting securities, by contract or otherwise.

“Credit Card Rewards Point” means a rewards point earned by a Cardholder through the Credit Card Rewards Program and awarded by FNBO as a result of the posting of a Qualifying Credit Card Transaction to such Cardholder’s Account in accordance with Schedule 2.7. Each Credit Card Rewards Point shall automatically convert to a Rewards Point in accordance with the program requirements set forth in Schedule 2.7 the rewards terms and conditions agreement between the Cardholder and FNBO and the terms and conditions of the Rewards Program.

“Credit Card Rewards Program” means the rewards program offered by FNBO and associated with the Program, through which Credit Card Rewards Points are offered to Cardholders prior to their conversion to Rewards Points in the Rewards Program.

“Customer List” means a listing of (a) all the names of Co-Brand Partner’s customers; (b) their addresses (including street, city, state and zip code); (c) e-mail addresses (when available); and (d) telephone numbers (when available). Co-Brand Partner shall exclude from the Customer List customers who have not reached the age of majority, customers who have exercised their right to opt-out of marketing solicitations (or who failed to opt-in where required by Applicable Law or regulation) under Applicable Laws or Co-Brand Partner’s privacy policy.

“Discloser” means the party disclosing Confidential Information.

“Effective Date” means January 2, 2019.

“Electronic Solicitations” means solicitations conducted electronically and includes, but is not limited to, internet advertising, electronic mail solicitations, website solicitations and website links.

“Execution Date” has the meaning set forth in the introductory paragraph hereto.

“Extension Term” has the meaning set forth in Section 4.1.

“FFIEC” means Federal Financial Institutions Examination Council.

“FNBO Proprietary Rights” means: (a) Cardholder Lists; (b) Promotional Materials; (c) the information on the FNBO Website, excluding any Co-Brand Partner Proprietary Rights; (d) any domain names FNBO registers for FNBO’s use on the world wide web; (e) FNBO Marks; (f) the name of FNBO; (g) all materials related to Accounts and the Program in any form or medium including cardmember agreements, agreements, servicing materials, disclosures, notices, Cardholder correspondence, statements, ancillary product materials and any other Program materials, excluding any Co-Brand Partner Proprietary Rights; and (h) any and all information, ideas, concepts, artwork, graphics, applications and any other proprietary rights of FNBO used in creating the FNBO Website or Promotional Materials. For the avoidance of doubt, FNBO Proprietary Rights do not include any Co-Brand Partner Marks, the name of Co-Brand Partner or any information, ideas, concepts, artwork, graphics, applications or other materials developed or paid for by Co-Brand Partner.

“FNBO Website” means the applicable portion of FNBO’s website located on the internet at a domain registered, owned and maintained by FNBO.

“Good Standing” means with respect to an Account, that as of the date of such determination all payments have been made when due, charge privileges have not been revoked or suspended, the credit limit is not exceeded, had a balance greater than \$0.00 in each of the last six billing cycles or on which finance charges have been billed in each of the last six billing cycles, and all other requirements of the applicable Cardmember Agreement have been complied with as of the applicable date.

“Hot Lists” means a Customer List provided by Co-Brand Partner consisting of (a) members of Co-Brand Partner’s Rewards Program and other customers with recent activity with Co-Brand Partner and (b) their addresses (including street, city, state and zip code). By way of example, Hot Lists might be comprised of recent redeemers, new rewards program enrollees, recent customers, and/or rewards members with a change in status. The Hot Lists shall exclude customers who have exercised their right to opt-out of marketing solicitations under Applicable Laws or Co-Brand Partner’s privacy policy or failed to opt-in where required by Applicable Law or regulation.

“Indemnified Party” means the party receiving indemnification from the Indemnifying Party under this Agreement.

“Indemnifying Party” means the party providing indemnification to the Indemnified Party under the terms of this Agreement.

“Inserts” has the meaning given in Section 2.4(b).

“Interchange Rate” means the weighted average blend of the actual interchange rates applied by the Network to transactions under the Program.

“Launch Date” means June 3, 2014, the date that the first solicitation (direct mail or electronic) for Cards was conducted under the Program.

“Marks” means names, trademarks, service marks, trade names, logos, copyrights and other proprietary materials and information.

“Network” means, as applicable, American Express Travel Related Services, Inc.; DFS Services LLC; MasterCard International, Inc. or Visa U.S.A., Inc.

“Network Rules” means the bylaws, procedures, rules, standards and regulations of any Network, and any determination or finding of a Network, applicable to or binding upon a party’s duties or obligations with respect to the Program.

“Net Retail Sales” means the amount of valid net purchase transactions posted to Accounts, but shall not include the aggregate amount of: (a) all refunds to Accounts, such as credit for returned merchandise or disputed billing items; (b) those amounts representing annual fees, finance charges, and other bank fees or charges posted to Accounts (such fees include, but are not limited to, late fees, return check fees, over limit fees, credit insurance premiums, cash advance fees, balance consolidation fees, collection costs and administrative fees); and (c) the amount of all cash advance transactions and/or cash advance transaction fees (which include balance transfers and the use of special checks).

“Nominated Purchaser” has the meaning given to such term in Schedule 3.7.

“Nonpublic Personal Information” means any information from or about Consumers that: (a) relates to any Consumer; (b) relates to, or derives from, any transaction between FNBO or its Affiliates and any Consumer; or (c) is a list, description or other grouping of Consumers. Nonpublic Personal Information includes, but is not limited to, application, Account and transaction information, Cardholder Lists, Consumer names and addresses, consumer report information or information derived therefrom, and the fact that an individual is or was a customer of FNBO or any of its Affiliates.

“PCI DSS” means Payment Card Industry Data Security Standard.

“Program” means the credit card program established pursuant to this Agreement, including all aspects of the marketing, underwriting, delivery, administration, servicing, collection and termination of the Accounts and the respective obligations of the parties under the Agreement with respect to the Accounts, Cards and Cardholders.

“Program Assets” has the meaning given thereto in Schedule 3.7, which is hereby incorporated into and made part of this Agreement.

“Promotional Materials” means all marketing, advertising and solicitation materials provided or made available to Co-Brand Partner or utilized in any marketing campaign which may include, but is not limited to, applications, banners, signs, take-one applications, take-one holders, take-one solicitation materials and Electronic Solicitations.

“Purchase Option” has the meaning given to such term in Schedule 3.7 hereto.

“Qualifying Credit Card Transaction” has the meaning given to such term in Schedule 2.7, Mandatory Terms, Paragraph 8.

“Recipient” means the party receiving Confidential Information.

“Red Flags” means patterns, practices, or specific activities that indicate the possible existence of identity theft.

“Renewal Term” means each successive three year period following the completion of the Extension Term.

“Rewards Account” has the meaning set forth in Schedule 2.7

“Rewards Point” means a rewards point earned by a member of the Rewards Program including a rewards point awarded by the automatic conversion of a Credit Card Rewards Point in accordance with Schedule 2.7.

“Rewards Program” means the “Ufly Rewards” program or its replacement as set forth in Section 2.7 and Schedule 2.7, (which is incorporated by reference) of this Agreement.

“Sales Employee” has the meaning given in Section 10.7

“Solicitation Account” means a new Account which is not an Application Account.

“Subcontractor” means any person or entity that has a business arrangement with Co-Brand Partner, by contract or otherwise, to perform duties, conduct activities or provide services, or that has any other responsibilities or obligations related to the Program in any way or that involves such person or entity obtaining, maintaining, viewing or accessing FNBO Nonpublic Personal Information. Without limiting the generality of the foregoing sentence, the parties acknowledge and agree that Olson, Inc. shall be a Subcontractor of Co-Brand Partner for the purpose of administering the Co-Brand Partner Reward Program.

“Term” means the Extension Term and each Renewal Term.

“Termination Date” means the date the contract is terminated whether pursuant to Section 9.1 or otherwise.

“UDAAP” means acts or practices which are unfair, deceptive or abusive as provided under Applicable Law.

## SECTION 2: PROMOTIONS

2.1 Solicitations. Co-Brand Partner authorizes FNBO to conduct direct mail, telemarketing, Electronic Solicitations and other promotional activities to the individuals on Customer Lists. Co-Brand Partner shall provide camera ready artwork of its Marks to FNBO for use on Cards, Promotional Materials and related materials and items. Unless otherwise provided in this Agreement, Co-Brand Partner and FNBO are solely responsible for their own costs and expenses of performance under this Agreement. FNBO may, at its option and in its sole discretion, discontinue marketing in general or through any specific channel at any time based on administrative, compliance, or reputational concerns.

2.2 Co-Brand Partner’s Participation. Co-Brand Partner agrees to continuously and diligently support and endorse the Card products and to cooperate as reasonably requested by FNBO in all marketing and solicitation activities that FNBO desires to conduct. Without limiting the generality of the foregoing, Co-Brand Partner agrees to: (a) participate in a minimum of 4 direct mail programs per Contract Year, (b) continuously promote solicitations at airline counters and in airline terminals, (c) participate in a minimum of 4 internet solicitations per Contract Year; (d) provide Customer Lists and Hot Lists to FNBO pursuant to Section 2.3; (e) establish and maintain prominent hyperlinks from Co-Brand Partner’s Website to FNBO’s Website, provided, however, that FNBO may disable the hyperlinks at any time if FNBO is or becomes concerned about compliance or the security of the FNBO Website; (f) establish and maintain references to the Card products on Co-Brand Partner’s Website; (g) continuously promote the Card products in the Co-Brand Partner in-flight magazine; and (h) prominently display Promotional Material on all Co-Brand Partner ticket counters.

2.3 Customer Lists. (a) Co-Brand Partner will provide FNBO with updated Customer Lists on a quarterly basis. Customer Lists must be delivered to FNBO by Co-Brand Partner on or before the 15th calendar day after the commencement of each calendar quarter. Co-Brand Partner will provide FNBO with an updated Hot List on a monthly basis, which must be delivered to FNBO by the last Business Day of each month. Co-Brand Partner will provide the Customer Lists and Hot Lists at no cost to FNBO.

(b) Although FNBO may choose to do so, FNBO is under no obligation to solicit each and every person listed on any Customer List or Hot List. Co-Brand Partner shall be the sole and exclusive owner of the Customer Lists and Hot Lists. Co-Brand Partner grants FNBO and its Affiliates a non-exclusive and royalty free license to use the Customer Lists and Hot Lists during the Term. Co-Brand Partner agrees to indemnify and hold FNBO harmless against any claims (including court costs, attorney’s fees and the cost of enforcing this indemnity provisions) that Co-Brand Partner’s authorizing FNBO to use the Customer Lists and Hot Lists is unauthorized, improper or illegal.

(c) The initial Marketing Plan (defined below in Section 2.10) prepared by the Parties will provide for Co-Brand Partner to conduct all solicitations of FNBO's Cards to individuals on the Customer List and Hot List during an initial two (2) month period, which shall begin no later than March 31, 2014. The form of all such solicitations and solicitation materials shall be subject to FNBO's prior review and written approval accordance with Section 2.11(b) of this Agreement. Co-Brand Partner shall bear all costs for any solicitations conducted during this initial two (2) month period, and FNBO shall cooperate with Co-Brand Partner in the solicitation of FNBO's Cards to individuals on the Customer List and Hot List during this initial two (2) month period. Notwithstanding the foregoing, after May 31, 2014, FNBO may solicit Cards to persons identified on any Customer List and Hot List provided to FNBO by Co-Brand Partner during the Term.

#### 2.4 Promotional Materials; Inserts.

(a) FNBO will provide, at FNBO's expense, a reasonable quantity of customized take-one applications and materials for airline counter solicitations. Co-Brand Partner agrees not to use any Promotional Materials or other references pertaining to FNBO or any of FNBO's credit cards, products or services without FNBO's prior written authorization and approval of the form, content, specifications and quality thereof. FNBO agrees to provide Promotional Materials containing Co-Brand Partner's Marks to Co-Brand Partner for Co-Brand Partner's prior approval (such approval not to be unreasonably withheld). FNBO may consider Co-Brand Partner's failure to respond within five business days to be an approval. If Co-Brand Partner requests non-standard solicitations or special inserts, FNBO may request prior to the production of such materials that Co-Brand Partner reimburse FNBO for any additional cost which may be incurred. Upon termination of this Agreement, Co-Brand Partner shall: (a) promptly return all Promotional Materials and all other solicitation materials whatsoever that FNBO supplied to Co-Brand Partner or that Co-Brand Partner has in its possession; and (b) delete, discontinue and cease all Electronic Solicitations.

(b) Co-Brand Partner and FNBO will, at Co-Brand Partner's sole cost and expense (including any incremental postage costs) and subject to Applicable Law, FNBO's policies (including privacy policies) and FNBO system requirements and, FNBO operational limitations, mutually agree to the content, targeting, and method of distribution of Cardholder inserts ("**Inserts**") and statement messaging. FNBO shall provide specifications and updates to specifications for Insert production and distribution, including dates on which Inserts and statement messaging need to be received by FNBO for timely inclusion. Co-Brand Partner will be responsible for producing inserts and statement messaging that are recommended for inclusion by Co-Brand Partner. Notwithstanding the foregoing, any insert or statement message that FNBO reasonably determines is necessary to comply with Applicable Law or Network Rules shall be the responsibility of FNBO in all respects and shall take precedence over any Co-Brand Partner inserts or statement messages. The content and distribution of the Inserts and statement messages shall be subject to the prior written approval of FNBO, such approval not to be unreasonably withheld, delayed or conditioned. FNBO will advise Co-Brand Partner if it reasonably believes that the content of statement inserts or messages proposed by Co-Brand Partner for distribution to Cardholders would conflict with Applicable Law, Network Rules, product offerings, FNBO policies (including privacy policies) or system requirements of FNBO or any Affiliate or its reputation and the parties shall work in good faith to modify the content so

it does not conflict with Applicable Law, Network Rules, product offerings, FNBO policies (including privacy policies), system requirements or reputation of FNBO or its Affiliates. In the event, FNBO and Co-Brand Partner are not able to reach mutual agreement on the content and targeting of any Insert or statement message, FNBO may at its sole discretion, refuse to include such Insert or statement message in a mailing and such refusal shall not be deemed to be a breach of this Agreement.

(c) For any given month, Co-Brand Partner will bear all incremental costs of postage incurred from Inserts that exceed FNBO's standard size and weight requirements for Inserts, excluding incremental costs associated with additional material inserted by FNBO to comply with requirements of law; provided, that FNBO shall notify Co-Brand Partner of any such incremental costs prior to mailing the Inserts and obtain Co-Brand Partner's prior written approval to proceed with the mailing. FNBO will provide standard size and weight requirements in advance. Co-Brand Partner will provide written notice to FNBO of its intent to include any Insert or statement message. Subject to limitations and conditions set forth above and in sub-section (b), FNBO shall include Co-Brand Partner-requested Inserts and statement messages.

2.5 Network Rules. Co-Brand Partner understands that FNBO's ability to offer Cards is based on the consent of the Network. Co-Brand Partner agrees to comply with all Network Rules applicable to the activities contemplated hereunder and such additional requirements as the Network may impose from time to time. In order to assure compliance with such Network Rules, Co-Brand Partner agrees not to produce communications, advertisements, or Promotional Materials regarding Cards without FNBO's prior written consent, such consent not to be unreasonably withheld, delayed or conditioned.

2.6 Exclusivity. Co-Brand Partner agrees that during the Term Co-Brand Partner shall not, by itself or in conjunction with others, directly or indirectly, or through any parent, Affiliate or subsidiary, offer or endorse, enter into any agreement with others for the provision of, or otherwise make available to Co-Brand Partner's customers, any other credit cards or credit card related products or services; *provided*, that the foregoing will not prevent Co-Brand Partner from entering into such an agreement during the final year of the Term, so long as no credit cards are issued, or marketing related to such credit cards conducted, prior to the Termination Date. The foregoing shall not be construed to prohibit Co-Brand Partner from providing Co-Brand Partner's customers with debit cards or engaging in or obtaining merchant processing activities. Co-Brand Partner may, after termination of this Agreement, offer current Cardholders the opportunity to participate in another credit card program that Co-Brand Partner endorses, provided Co-Brand Partner does not make such offer only to such Cardholders, but rather as a part of a general solicitation to Co-Brand Partner's customers or other persons identified independently of their status as Cardholders and provided further that no such existing Cardholders are directly or indirectly identified as Cardholders or offered incentives different from that offered to Co-Brand Partner's customers or other persons who are not Cardholders; *provided*, that the foregoing restriction shall not apply to Accounts transferred to Co-Brand Partner (or the Nominated Purchaser or the Alternative Nominated Purchaser as applicable) as a result of the exercise by Co-Brand Partner of the Purchase Option and the completed sale of Program Assets by FNBO. For clarity, Co-Brand Partner may not target Cardholders whose Accounts were not sold or transferred to Co-Brand Partner (or the Nominated Purchaser or Alternative Nominated Purchaser as applicable) as a result of the exercise by Co-Brand Partner of the Purchase Option and the completed sale of Program Assets by FNBO; provided that the foregoing will not limit Co-Brand Partner's right to market generally to the Customer List or to the members of the Rewards Program.



2.7 Rewards Program. Co-Brand Partner shall offer a Rewards Program to the Cardholders, and shall contain at least those terms set forth on Schedule 2.7 under the heading “Mandatory Terms.” To the extent that any such Mandatory Terms are not in effect as of Execution Date, Co-Brand Partner shall cause such Mandatory Terms to become effective as soon thereafter as reasonably practicable but no later than the Effective Date. The Rewards Program shall be operated in accordance with the terms set forth on Schedule 2.7 under the heading “Administration of Rewards Program.” Subject to any additional requirements on Schedule 2.7, Co-Brand Partner may also add, change, or modify other terms of the Rewards Program so long as such additions, changes, or modifications do not conflict with the Mandatory Terms. No such change may impose additional or altered obligations on FNBO without its consent, except to provide additional information that is readily available, may lawfully be provided subject to FNBO’s internal policies and procedures, and is no more burdensome to provide than any such information already being provided. Co-Brand Partner will notify FNBO of material changes in the Rewards Program in advance of the effective date of such material change, but in any event no less than 90 days in advance of the earlier of when Cardholders are notified thereof or the effective date of the change. Other terms for the Rewards Program include, but are not limited to, the terms set on Schedule 2.7 under the heading “Discretionary Terms.” Terms and Conditions for the Rewards Program (for purposes of disclosure to Cardholders) shall be established by Co-Brand Partner, but subject to FNBO’s approval, which shall not be unreasonably withheld. For avoidance of doubt, Co-Brand Partner and FNBO hereby acknowledge and agree that the Rewards Program is administered, owned, managed and maintained solely by Co-Brand Partner and, other than timely reporting of Credit Card Rewards Points based on Qualified Credit Card Transactions by Cardholders as outlined in this Agreement, FNBO is not responsible for any aspect or function of the Rewards Program, including, but not limited to, Co-Brand Partner’s products, services, decisions, or Co-Brand Partner’s refusal to honor Rewards Point redemption requests. Notwithstanding anything to the contrary in this Agreement, FNBO shall have full authority to cease participation in the Rewards Program based on administrative, compliance, or reputational concerns upon thirty (30) days’ notice to Co-Brand Partner. In the event that FNBO ceases its participation in the Rewards Program, either party may terminate this Agreement upon sixty (60) days written notice to the other party; *provided*, that in the event Co-Brand Partner exercises its Purchase Option, the Termination Date shall be extended as necessary to match the Purchase Date. For the avoidance of doubt, FNBO’s decision to cease participation in the Rewards Program, or any other termination of the Program, shall not change (a) FNBO’s obligation to pay compensation pursuant to Section 5.1 and Schedule 5.1 or (b) Co-Brand Partner’s obligation to honor all Rewards Points validly credited to Rewards Accounts prior to the effective date of such cessation or termination, subject to the terms and conditions of the Rewards Program.

2.8 Joint Marketing Steering Committee. Co-Brand Partner and FNBO shall establish a committee (the “Joint Marketing Steering Committee”) for the purpose of creating Marketing Plans (as defined below), proposed revisions to Marketing Plans, rewards programs and other matters regarding marketing of the Program. The Joint Marketing Steering Committee shall be comprised of at least two management-level employees representing Co-Brand Partner and at

least two management-level employees representing FNBO. The parties will endeavor to provide stability and continuity in the make-up of their respective Joint Marketing Steering Committee members throughout each calendar year of the term of this Agreement. The Joint Marketing Steering Committee will meet (whether in-person, via telephone or video conference, or any combination thereof) at least once per calendar quarter during the Term.

2.9 No Authority to Amend Agreement. The Joint Marketing Steering Committee is not authorized to amend any terms of this Agreement. Any amendments, modifications and substitutions to the Program proposed under any Marketing Plan, shall not be effective to bind either party hereto except and to the extent an amendment to this Agreement is signed by authorized representatives of Co-Brand Partner and FNBO in accordance with terms for amending this Agreement.

2.10 Marketing Plan. Prior to each meeting of the Joint Marketing Steering Committee, the parties will prepare a mutually-agreeable plan (“Marketing Plan”) that sets forth the parties’ marketing strategies for the calendar quarter immediately following the upcoming calendar quarter. As an example, the Marketing Plan prepared in the first quarter shall set forth strategies to be implemented in the third quarter. Each Marketing Plan should include proposed solicitation, activation and retention strategies and communication methods (i.e.-direct mail campaigns, statement inserts, statement messages, Electronic Solicitations, Co-Brand Partner employee incentive programs, and activation premium promotions (e.g., merchandise or other incentives provided to prospective Cardholders for completing applications for Accounts), etc.). Each Marketing Plan should also include a marketing calendar setting forth the proposed dates for completing the proposed marketing initiatives. Subject to Applicable Law, system limitations, Network Rules and FNBO’s procedures and policies (including privacy policies), FNBO and Co-Brand Partner agree to use commercially reasonable efforts to collaborate and develop strategies that are mutually agreed to by both parties and are designed to make account acquisition offers competitive within the context of a mutually agreed upon product and market definition. Notwithstanding anything to the contrary herein, both parties acknowledge and agree that the development and implementation of strategies designed to make account acquisition offers competitive within the context of a mutually agreed upon product and market definition is an aspirational goal and failure to reach mutual agreement on market definition or the development or implementation of such strategies shall not constitute a breach of this Agreement by either party.

2.11 Mutual Participation. (a) Co-Brand Partner and FNBO agree to jointly implement and participate in the agreed-upon Marketing Plans.

(b) Co-Brand Partner agrees not to use any Promotional Materials or other references pertaining to FNBO without FNBO’s prior written authorization and approval of the form, content, specifications and quality thereof. Co Brand Partner shall not, without the FNBO’s prior written consent: (1) conduct, other than as mutually agreed or contemplated by this Agreement, e-mail campaigns pertaining to FNBO’s credit cards; or (2) solicit or accept applications over the telephone.

(c) Notwithstanding the provisions of this Agreement providing, or allowing, for the mutual consent of the parties, FNBO shall have sole discretion and final decision-making authority with respect to the form and content of all solicitations for, and promotions of, the Cards and Accounts as well as communications with Cardholders and prospective Cardholder (including, without limitation, all marketing materials, statements, cardmember agreements, adverse action letters, collections, and other communications required to maintain, service, or terminate the Accounts), and notwithstanding that such materials contain Co-Brand Partner Marks, if such decisions are based on the application of Applicable Laws, regulations, regulatory guidance, judicial decree, or Network requirements as determined by FNBO in its sole and absolute discretion; *provided*, that in no event shall FNBO use Co-Brand Partner Marks on adverse action letters, default notices/letters, or other collections communications without the consent of Co-brand Partner.

#### 2.12 Annual Marketing Spend Commitment.

(a) FNBO will spend not less than seven hundred fifty thousand dollars (\$750,000), in the aggregate, toward materials and activities intended to market and solicit Cards and Accounts during each Contract Year of the Extension Term provided that during the Contract Year immediately preceding the Contract Year at issue, at least ten thousand (10,000) new Accounts were opened and Activated.

(b) If fewer than ten thousand new Accounts are opened and Activated in a Contract Year, FNBO will commit to spend in the immediately following Contract Year at least an amount equal to the product of fifty dollars (\$50) multiplied by the number of new Accounts were opened and Activated in the earlier Contract Year.

(c) Sums spent on the following types of materials and activities will be counted toward the determination of FNBO's compliance with this marketing spend commitment: direct mail; email marketing campaigns; premium promotions; activation and usage campaigns and other portfolio marketing; take-one solicitations; take-one holders; promotional materials; new account fulfillment and collateral; employee incentives; incremental rewards expense; all expenses related to creative design; website development and maintenance; publication advertisements; direct expenses for marketing efforts; and other mutually agreed upon marketing expenses.

(d) Notwithstanding the foregoing subsections of this Section 2.12, FNBO's obligation to spend the amounts specified in such subsections shall end upon Co-Brand Partner's issuance of an Evaluation Notice, exercise of its Purchase Option or any termination of this Agreement [except in the case of a termination (and subsequent exercise of the Purchase Option) by Co-Brand Partner pursuant to Section 9.2.

2.13 CAN-SPAM. Co-Brand Partner agrees, acknowledges, represents, and warrants that for all commercial electronic mail messages that Co-Brand Partner sends advertising, promoting or sponsoring the Program, Co-Brand Partner shall: (a) comply with all requirements of the Controlling the Assault of Non-Solicited Pornography Act of 2003, 15 U.S.C. §7701 et. seq., and its implementing regulations, as amended from time to time ("CAN-SPAM Act"); (b) be and serve as the "designated sender" for purposes of the CAN-SPAM Act for any commercial electronic mail message that promotes or advertises Co-Brand Partner's products, services or Co-Brand Partner Website in addition to the Program, and (c) fulfill all requirements and obligations under the CAN-SPAM Act necessary for Co-Brand Partner's classification as the "designated sender" of such commercial electronic mail messages.

2.14 Instant Issuance of Accounts. Upon mutual agreement of the parties, FNBO and Co-Brand Partner will use commercially reasonable efforts to implement a systematic process to integrate an instant approval and contemporaneous purchase authorization for Co-Brand Partner's Customers. FNBO will absorb expenses for its own internal development and implementation of such process. Co-Brand Partner will absorb expenses for its own internal development and implementation of such process, platform integration, ongoing maintenance and operating expenses for such process. FNBO and Co-Brand Partner shall perform their duties related to instant approval and purchase authorization in strict accordance with Applicable Laws, regulations and FNBO instructions and training materials.

2.15 UDAAP. From time to time, either party may notify the other party of acts or practices associated with the Program, the Rewards Program or the Credit Card Rewards Program which such party or any regulator with jurisdiction over such party considers to be UDAAP. Upon receipt of such notification, the parties will reasonably cooperate to address such concerns. To the extent that the parties are not able to reach agreement regarding such alleged UDAAP, the party that provided the notice may terminate this Agreement upon 30 days prior written notice; *provided*, that if Co-Brand Partner exercises its Purchase Option, the Termination Date shall be deferred for such period of time as is reasonably necessary to permit Co-Brand Party to exercise its rights in Schedule 3.7. For the avoidance of doubt, the existence of practices which are asserted to be UDAAP shall not constitute a breach of this Agreement unless such practices breach a specific provision herein.

2.16 Credit Card Rewards Program. FNBO shall ensure that the Credit Card Rewards Program (a) conforms to the Mandatory Terms, Applicable Law and Network Rules and (b) does not conflict in any way with the Rewards Program.

### SECTION 3: ACCOUNTS

3.1 Accounts. (a) FNBO agrees to issue Accounts to Cardholders when appropriate and in accordance with the terms of this Agreement. All decisions regarding the approval of applications for Accounts shall be made at FNBO's sole and absolute discretion and Co-Brand Partner shall have no power or authority to bind FNBO to approve applications. Co-Brand Partner shall forward to FNBO on the first business day following Co-Brand Partner's receipt any applications Co-Brand Partner receives. Co-Brand Partner shall not impose any fees whatsoever on applicants or Cardholders for Accounts.

(b) FNBO will assess each open Account a \$69 annual fee (the "Annual Fee"). Notwithstanding the foregoing, Accounts opened prior to November 1, 2018 and still in their initial year of enrollment shall be charged the Annual Fee upon the first anniversary of the opening of their account.

**3.2 Cardmember Agreements.** The terms and conditions for Accounts issued pursuant to this Agreement will be established by FNBO and are subject to change from time to time in FNBO's sole and absolute discretion. FNBO and Co-Brand Partner will use commercially reasonable efforts to ensure that the Program is competitive with competing co-branded airline credit card programs. Accounts will be FNBO's sole and exclusive property (subject to the participation or other interests FNBO may grant to others; provided that any such participations or other interests shall be subject to Co-Brand Partners's Purchase Option) and Co-Brand Partner will not be considered a co-lender or joint owner with respect thereto or have any right or interest therein. FNBO shall have sole responsibility and control over the terms and conditions on which FNBO extends credit, including, without limitation, terms and conditions pertaining to solicitation and application procedures, credit criteria and evaluation, annual fees, promotional rates, and all servicing, default, collection and termination policies and procedures. FNBO may communicate with Cardholders to the same extent and through the same methods that FNBO communicates with FNBO's other customers (e.g., sending activation and retention mailings, fee income product promotions, statement messages and inserts, etc.). Terms of cardmember agreements, disclosures and other credit card terms and conditions between FNBO and Cardholders shall govern Accounts and such cardmember agreements shall specify that the laws of Nebraska and federal law, as applicable, shall govern the terms and conditions of such Accounts and credit extensions to Cardholders. Notwithstanding any other limitations contained in this Agreement, FNBO shall have the right to amend such cardmember agreements, disclosures and other credit card terms and conditions at any time; *provided*, that unless Applicable Law requires an immediate change, prior to amending the cardholder agreements, FNBO shall give Co-Brand Partner at least thirty (30) days prior notice of such change and, if requested by Co-Brand Partner, shall meet and consult with Co-Brand Partner regarding any concerns Co-Brand Partner may have with such change; *provided, further*, that such consultation shall not in any way limit FNBO's sole and absolute discretion regarding the terms and conditions of the cardmember agreements. To the extent applicable law requires an immediate change of the cardmember agreements, FNBO shall notify Co-Brand Partner of such change as promptly as commercially reasonable.

**3.3 Endorsement of Checks.** Co-Brand Partner acknowledges that Cardholders may from time to time make payment to FNBO by checks made payable to Co-Brand Partner, Co-Brand Partner acknowledges that FNBO may, but need not, permit such mode of payment as a customer convenience only and that the presence of Co-Brand Partner's name on such checks does not confer any right or interest therein to Co-Brand Partner and FNBO shall be the sole owner of such checks. Co-Brand Partner consents to FNBO's endorsement, during and after the Term hereof, on FNBO's behalf, of Co-Brand Partner's name on all such checks in which FNBO has an interest.

**3.4 Accounts after Termination.** Subject to Co-Brand Partner's exercise of its Purchase Option, termination of this Agreement for any reason shall not alter or affect FNBO's ownership of and other rights and interests in the Accounts; *provided, however*, that upon earlier of the scheduled expiration of each Card or 180 days after the Termination Date, FNBO shall, at its option, convert such Card to one of FNBO's proprietary cards or terminate such Account, whereupon the license granted to FNBO under this Agreement shall terminate. Although FNBO has no obligation to do so, in its sole and exclusive discretion after termination of this Agreement, subject to Co-Brand Partner's exercise of its Purchase Option, FNBO may issue in FNBO's own name: (a) credit cards to replace Cards previously issued to Cardholders pursuant to this Agreement and not yet having reached their scheduled expiration dates; and (b) credit cards to applicants whose applications are received after the termination of this Agreement.

3.5 Service Levels. FNBO agrees to provide customer service during the term of the Agreement and shall target the service levels described in this Section 3.5. FNBO shall use commercially reasonable efforts to:

- a. Answer seventy-five percent (75%) of all customer care telephone calls received within thirty (30) seconds or less, measured on a monthly basis;
- b. Maintain an abandonment rate of four percent (4%) or less of customer care telephone calls received and which have been on hold for at least thirty (30) seconds, measured on a monthly basis;
- c. Resolve ninety-six percent (96%) of customer care issues during the customer's first call regarding the issue;
- d. Respond to ninety percent (90%) of all customer care written correspondence, excluding returned mail, within five (5) business days or less;
- e. Acknowledge all customer care email inquiries within one (1) business day;
- f. Issue a new credit card to ninety-five percent (95%) of Cardholders by first class mail within three (3) business days upon approval of the application; and
- g. Maintain annual uptime of its website ninety-eight percent (98%) of the time, excluding planned downtime and regular maintenance, subject to the provisions of Section 11 of this Agreement.

Notwithstanding anything to the contrary, the foregoing service levels are targets only. Failure to achieve any service level shall not constitute a breach of the Agreement by FNBO. If any one of these service levels is not met in any calendar month period, FNBO will notify Co-Brand Partner and communicate the efforts FNBO is making to improve the deficiency, and FNBO shall have one calendar month thereafter to return the deficient service level or levels to the target. If a deficient service level has not returned to or exceeded the target in the month following notification of Co-Brand Partner, the matter shall be escalated to Joint Marketing Steering Committee for resolution.

FNBO's performance on these service levels will be excused if FNBO cannot meet the service levels due to events or occurrences beyond the reasonable control of FNBO or its Affiliates. In such an event, FNBO shall use commercially reasonable and good faith efforts to quickly meet the service levels described in this Section 3.5.

3.6 Merger. In the event: (a) Co-Brand Partner sells or exchanges substantially all of its assets; (b) Co-Brand Partner consummates a consolidation, reorganization, recapitalization, reclassification of its existence or merger; or (c) there is a change in the ownership interests in Co-Brand Partner in a single transaction or a related series of transactions that constitutes a change of 51% or more of the outstanding ownership interest of Co-Brand Partner (any of the foregoing, a "**Change of Control**"), then FNBO may terminate this Agreement upon 60 days written notice to Co-Brand Partner made within 30 days of the later of FNBO receiving written notice of such Change of Control or the effective date of such Change of Control. If any of the events listed in the preceding sentence occur and FNBO does not terminate this Agreement

within such 30 day period, subject to the following sentence, (i) this Agreement shall remain in full force and effect as the obligation of the Co-Brand Partner, FNBO and their respective successors and permitted assigns; (ii) any credit card program to which the acquiring or merging entity is a party shall not constitute a breach of Section 2.6; and (iii) if any credit card program to which such acquiring or merging entity is a party has a longer term, the Term of this Agreement shall be extended to be co-terminus with such program. If this Agreement would constitute a breach under any credit card program to which the acquiring or merging entity is a party, such acquiring or merging entity may terminate this Agreement upon 60 days written notice to FNBO, in which event the Purchase Option shall not apply.

3.7 Purchase Option. If this Agreement is terminated for any reason other than by FNBO pursuant to Section 9.2, Co-Brand Partner shall have a one-time option to purchase the Program Assets pursuant and subject to (a) Applicable Law; (b) Network Rules; and (c) the terms of this Agreement and the Purchase Option Schedule. Co-Brand Partner acknowledges that if it exercises its Purchase Option, the Accounts shall be subject to the terms and conditions governing such Accounts at the time of transfer. Subject to Applicable Law and Network Rules and regulations, FNBO acknowledges and agrees that it will not change the terms and conditions governing the Accounts during the last two Contract Years of the term without the prior written consent of Co-Brand Partner, other than changes which apply across all of FNBO's credit card programs.

#### **SECTION 4: TERM**

4.1 Extension Term. The Extension Term of this Agreement shall commence on July 1, 2018 and extend for a period of seven (7) years and shall end on June 30, 2025.

4.2 Renewals. Thereafter, this Agreement shall automatically renew for successive Renewal Terms of three (3) years each unless terminated as provided herein.

#### **SECTION 5: COMPENSATION**

5.1 Compensation. FNBO agrees to pay Co-Brand Partner Compensation set forth in Schedule 5.1, the Compensation Schedule effective as of July 1, 2018. In addition, no later than fourteen (14) calendar days following the receipt by FNBO of a fully executed copy of this Agreement, FNBO shall pay to Co-Brand Partner a one-time signing bonus in the amount of One Million Dollars (\$1,000,000) to an account designated by Co-Brand Partner; provided, that if the Termination Date occurs prior to July 1, 2025, Co-Brand Partner shall refund to FNBO a pro rata portion of such signing bonus for the curtailed portion of the Extension Term.

5.2 Payments. Compensation will be calculated and paid on a calendar year quarterly basis and accompanied by FNBO's standard reports. Any difference in Compensation payable to Co-Brand Partner in Section 5.1 for the period from July 1, 2018 to the Execution Date of this Agreement shall be reconciled and settled with Co-Brand Partner no later than thirty (30) days following the Execution Date.

5.3 Effect of Termination. Termination of this Agreement for any reason shall terminate Co-Brand Partner's right to receive Compensation, provided that previously accrued and unpaid Compensation shall be reconciled and paid to the date of termination.

5.4 No Duplicate Compensation. FNBO shall not pay Co-Brand Partner any duplicate Compensation if Accounts on which such Compensation is calculated represent substitute or alternative accounts, including, but not limited to, Accounts established: (a) due to the loss or theft of a Cardholder's credit card; (b) as a result of former joint Cardholders requesting individual accounts; (c) due to an upgrade of an existing Account; (d) as subaccounts of an Account; or (e) multiple cards issued under a single Account.

5.5 Subcontractors. Notwithstanding anything in this Agreement to the contrary, in no event will FNBO have any obligation to pay any Compensation, expenses, fees or any other amounts whatsoever to any Subcontractor.

5.6 Interchange. In the event that the Interchange Rate is decreased by at least fifteen percent (15%) for a period of at least six (6) months due to a change in Applicable Law or Network requirements, FNBO may provide written notice to Co-Brand Partner requesting a renegotiation of the Compensation paid to Co-Brand Partner. Such notice shall specify the reduction in the Interchange Rate, the resulting reduction in FNBO revenue and the reduction in Compensation sought by FNBO. Following such notice the Joint Marketing Steering Committee will meet within fifteen (15) business days to discuss and evaluate changes to the Program, including reductions in Compensation. If the Joint Marketing Steering Committee fails to reach agreement on changes to the Program within thirty (30) days of its first meeting, FNBO shall have the right to terminate the Program.

## SECTION 6: INTELLECTUAL PROPERTY

6.1 Marks. Each party retains all rights and interests in its own Marks. No party shall have any right or interest in the other party's Marks except as specifically provided in this Agreement. Neither party shall use the Marks of the other party except as provided herein. Co-Brand Partner acknowledges the Network's ownership of its Marks.

6.2 License. Each party hereby grants to the other party and its Affiliates for the Term and for such additional period as is set forth in this Agreement after the Term, a non-exclusive and royalty-free license to use granting party's name and Marks for the purposes set forth in this Agreement. In the event of any change in the granting party's name or Marks, the granting party shall bear the expense of and promptly reimburse the other party for any additional expenses such other party incurs in connection with the use of the changed name or altered Marks to the extent the granting party requests a change in the use of the changed name or altered Marks.

6.3 Representations and Warranties. Each Party represents and warrants that during the Term, and for such additional period as is set forth in this Agreement after the Term with respect to the Marks in which it is granting a license pursuant to Section 6.2: (a) such granting party shall be the sole and exclusive owner of its Marks and has the exclusive authority to license its Marks for the uses detailed in this Agreement; (b) the granting party's Marks do not infringe the rights of any third party; (c) the granting party's Marks are validly and duly registered, filed, approved and certified by the applicable federal and state agencies and authorities; (d) the license and use of the granting party's Marks pursuant to this Agreement will not violate or breach any other contracts; and (e) the granting party will not enter into any other contracts which would



limit the license or use of Co-Brand Partner's Marks hereunder or cause a breach of this Agreement or future contracts. Co-Brand Partner further represents and warrants that it is lawfully using the d/b/a "Sun Country Airlines," and that Co-Brand Partner has completed any registration of its d/b/a "Sun Country Airlines" that is required by state or federal law. A breach of any of the representations and warranties contained in this Section 6.3 shall constitute a material breach of the Agreement. Each party shall immediately notify the other party upon the breach of any of the representations and warranties contained within this Section 6.3.

#### 6.4 Proprietary Rights.

(a) No provision of this Agreement shall be construed to grant Co-Brand Partner any right, title, interest, or license in, to or under the FNBO Proprietary Rights (which shall be the sole and exclusive property of FNBO or an Affiliate of FNBO). FNBO Proprietary Rights shall be considered FNBO's confidential and proprietary information and FNBO's trade secret. Without FNBO's prior written approval, Co-Brand Partner shall not attempt to assemble or compile any list of Cardholders or persons holding Accounts to be used for any purpose other than as strictly related to this Agreement.

(b) No provision of this Agreement shall be construed to grant FNBO any right, title, interest, or license in, to or under the Co-Brand Partner Proprietary Rights (which shall be the sole and exclusive property of Co-Brand Partner or an Affiliate of Co-Brand Partner). Co-Brand Partner Proprietary Rights shall be considered Co-Brand Partner's confidential and proprietary information and Co-Brand Partner's trade secret. Without Co-Brand Partner's prior written approval, FNBO shall not attempt to assemble or compile any list of Customers or members of the Rewards Program to be used for any purpose other than as strictly related to this Agreement.

### **SECTION 7: CONFIDENTIALITY**

7.1 Use and Confidentiality of Confidential Information. Recipient: (a) shall use Discloser's Confidential Information solely for performing its obligations under this Agreement; (b) shall not sell, rent, lease or otherwise directly or indirectly disclose Discloser's Confidential Information to any third party; (c) shall take all reasonable steps to protect the confidentiality of Discloser's Confidential Information, using the same standard of care used to protect its own confidential information, but in no event using a standard of care considered less than reasonable under the circumstances; (d) shall give access to Discloser's Confidential Information only to those employees, officers or agents who have a need to know in connection with the performance of Recipient's obligations under this Agreement; (e) shall not copy or duplicate Discloser's Confidential Information except as necessary to fulfill its obligations under this Agreement; (f) shall comply with privacy laws and regulations applicable to its business; and (f) shall not store or allow access to Confidential Information outside of the United States. If Recipient is permitted to retransmit any Confidential Information under the terms of this Agreement, the mode of retransmission must be at least as secure as the mode by which Discloser transmitted Confidential Information to Recipient. Upon request by Discloser, Recipient shall promptly destroy Discloser's Confidential Information or return Discloser's Confidential Information to Discloser in the same format as Discloser provided Confidential Information to Recipient. Nothing herein shall be construed to grant Recipient any rights, title or interest in or to any of Discloser's Confidential Information.

7.2 Exclusions. The confidentiality obligations in this Confidentiality Section do not apply to Confidential Information that: (a) is, at the time of disclosure to Recipient, or thereafter becomes, through no act or omission of Recipient, a part of the public domain (except that Nonpublic Personal Information remains subject to such obligations regardless of its availability in the public domain); (b) was in Recipient's lawful possession without an accompanying secrecy obligation prior to the disclosure, as documented in Recipient's written records; (c) is hereafter lawfully disclosed to Recipient by a third party without an accompanying secrecy obligation or breach of any duty or agreement by which such third party is bound; or (d) is independently developed by Recipient.

7.3 Confidentiality of Agreement. Both parties agree that the terms and conditions of this Agreement shall be treated as Confidential Information and that no reference to the terms and conditions of this Agreement or to activities pertaining thereto can be made in any form without the prior written consent of the other party; provided, however, that the general existence of this Agreement shall not be treated as Confidential Information. Either party may disclose the terms and conditions of this Agreement: (a) as required by any court or other governmental body; (b) as otherwise required by law including a party's obligations under applicable securities laws; (c) to legal counsel of the parties; (d) in confidence to accountants, Networks, banks, proposed investors, and financing sources and their advisors; (e) in confidence in connection with the enforcement of this Agreement or rights under this Agreement; or (1) in confidence in connection with a merger or acquisition or proposed merger or acquisition, or the like.

7.4 PCI DSS; FFIEC. Prior to FNBO providing Co-Brand Partner access to Nonpublic Personal Information in connection with the Program, Co-Brand Partner shall certify to FNBO that it is level two Payment Card Industry Data Security Standard validated, provide FNBO evidence of such validation in the form of a Report on Compliance conducted by a Payment Card Industry Security Standards Council approved Qualified Security Assessor or the Attestation of Compliance executed by the Qualified Security Assessor (and thereafter provide such evidence annually as reasonably requested), and comply with the Payment Card Industry Data Security Standard, FFIEC and any Network Rules related to protecting any information concerning Consumers. If such validation is required, Co-Brand Partner is required to pay all expenses associated with maintaining such Payment Card Industry Data Security Standard validation including, but not limited to, the costs of the penetration testing associated therewith. In the event that a Subcontractor possesses, stores, processes or transmits Nonpublic Personal Information in connection with the Program, FNBO may require, as a condition precedent to such Subcontractor possessing, storing, processing or transmitting Nonpublic Personal Information: (a) that such Subcontractor be PCI DSS validated; (b) provide evidence of such validation to Co-Brand Partner at least annually and upon request; (c) comply with any rules and regulations of the Network related to protecting Nonpublic Personal Information; and (d) upon request by FNBO from time to time, Co-Brand Partner will provide FNBO with PCI DSS validation of Subcontractors. Prior to FNBO providing Co-Brand Partner access to Nonpublic Personal Information in connection with the Program, Co-Brand Partner will perform a penetration test of all systems in which Nonpublic Personal Information relating to the Program is processed or stored and will notify FNBO if any vulnerabilities or issues are identified by such

penetration tests that result in the system being noncompliant with FFIEC or PCI DSS. All such vulnerabilities or issues will be remediated by Co-Brand Partner to FNBO's satisfaction within an industry acceptable time frame, but no longer than thirty (30) days after the vulnerabilities or issues are identified; provided that if such vulnerability or issue is not reasonably capable of being resolved within such thirty (30) day period, with in such longer period as may be required so long as Co-Brand Partner is diligently seeking to resolve such vulnerability or issue but no later than sixty (60) days after the vulnerabilities or issues have been identified. Co-Brand Partner will conduct penetration testing to validate such remediation and will provide FNBO with a copy of such penetration test results within ten (10) business days after request. Co-Brand Partner shall thereafter perform such a test annually. If Co-Brand Partner is unable to remediate such vulnerabilities or issues, FNBO may terminate this Agreement without penalty with thirty (30) days prior written notice; *provided*, that in the event Co-Brand Partner exercises its Purchase Option, the Termination Date shall be extended as necessary to match the Purchase Date.

7.5 Exceptions. This Confidentiality Section shall not be deemed to prohibit disclosures: (a) required by Applicable Law, regulation, court order or subpoena, provided that prior notice of any such disclosure has been given to Discloser in order to permit Discloser to take legal action to prevent the disclosure or seek an appropriate protective order; (b) as required in the course of an examination by governmental regulators with jurisdiction over Recipient; (c) to Recipient's professional auditors and counsel, provided that such advisors are obligated to maintain the confidentiality of the information they receive; or (d) to the applicable Network. If Recipient is permitted under the terms of this Agreement to provide Confidential Information to a third party, Recipient is responsible for ensuring that such third party is subject to binding confidentiality obligations with respect to Confidential Information which are at least as restrictive as those contained in this Section.

7.6 Information Security and Disposal Standards. Recipient agrees to implement a comprehensive written information security program that includes appropriate administrative, technical and physical safeguards to: (a) ensure the safety and confidentiality of Discloser's Nonpublic Personal Information; (b) protect against unauthorized access to and use of Discloser's Nonpublic Personal Information; (c) protect against anticipated threats or hazards to the security or integrity of Discloser's Nonpublic Personal Information; and (d) properly dispose of Discloser's Nonpublic Personal Information. Such measures shall be designed to be appropriate to meet the objectives of the Interagency Guidelines Establishing Information Security Standards (12 CFR Part 30—Appendix B, as amended from time to time). Recipient shall implement a written security and disaster recovery plan consistent with the standards and practices of Recipient's industry. Recipient further agrees to cooperate in Discloser's monitoring of Recipient's compliance with the foregoing obligations as reasonably requested by Discloser from time to time, including, without limitation, by providing Discloser with an opportunity to review and obtain copies of relevant audits, test results, reports and similar materials that Recipient might prepare or have prepared for it from time to time, to the extent the same may affect Discloser's Nonpublic Personal Information.

7.7 Notification of Breach. Recipient agrees to take appropriate actions to address any Breach, including to notify Discloser as soon as possible but no later than twenty four (24) hours after Recipient has concluded that a Breach or any of the following has occurred or is about to occur: (a) unauthorized access to or disclosure of Discloser's Confidential Information; (b) breach of this Confidentiality Section; or (c) any breach or attempted breach of its security related to areas, locations or computer systems which contain any of Discloser's Nonpublic Personal Information, including without limitation any instance of theft, unauthorized access by fraud, deception or other malfeasance or inadvertent access. Recipient shall stop the Breach immediately, but in any event not more than twenty four (24) hours after discovery of the breach. In the event of any such breach of this Confidentiality Section, unauthorized access, disclosure or breach or attempted breach of security, Recipient shall further provide to Discloser, in writing, such details concerning the incident in question as Discloser may request. Recipient shall, within an industry acceptable time frame, but no longer than thirty (30) days, after notice of such Breach and at its sole expense, implement an action plan to correct the Breach and prevent the continuation of such Breach, and shall promptly notify Discloser of the corrective action and measures taken.

7.8 Red Flags. To the extent applicable, Co-Brand Partner shall establish and maintain reasonable policies and procedures designed to detect, prevent and mitigate the risk of identity theft relating to Consumers, including but not limited to policies and procedures to detect patterns, practices, or specific activities that indicate the possible existence of identity theft, and shall ensure that any services are conducted in accordance with such policies and procedures. At present, the Parties agree that such policies and procedures are not currently applicable, but if the Parties agree that a subsequent change in program triggers such requirement, then, upon request by Co-Brand Partner, FNBO will provide suggestions to Co-Brand Partner related to such policies and procedures. If requested by FNBO, Co-Brand Partner shall promptly notify FNBO of any such patterns, practices, or specific activities that indicate the possible existence of identity theft and reasonably cooperate in FNBO's investigation of such matter

7.9 Breach. Breach of this Confidentiality Section shall give rise to irreparable injury, inadequately compensable in damages. Accordingly, Discloser may seek injunctive relief against the breach or threatened breach by Recipient of this Confidentiality Section, in addition to such legal remedies as may be available, including the recovery of damages.

7.10 Audit. FNBO agrees to maintain a current SSAE 16 SOC2 audit or equivalent (i.e. 3rd party audit such as AT501, SOX, Verizon report, ISO certification) and provide such audit to Co-Brand Party upon request. Co-Brand Partner agrees to cooperate with assisting FNBO in complying with its standard Co-Brand Partner due diligence obligations under applicable law. If FNBO provides Nonpublic Personal Information to Co-Brand Partner, Co-Brand Partner agrees to provide FNBO (including its internal and external auditors and governmental authorities) with reasonable access to its facilities, books and records and personnel in order to conduct an examination to verify performance by Co-Brand Partner of its obligations with respect to Nonpublic Personal Information. In the event that FNBO's audit reveals any vulnerabilities or issues, Co-Brand Partner shall remediate such vulnerabilities and issues within an industry acceptable time frame, but no longer than thirty (30) days after notice to Co-Brand Partner; provided that if such vulnerability or issue is not reasonably capable of being resolved within such thirty (30) day period, with in such longer period as may be required so long as Co-Brand Partner is diligently seeking to resolve such vulnerability or issue but no later than sixty (60) days after the vulnerabilities or issues have been identified. If Co-Brand Partner is unable to remediate such vulnerabilities or issues, FNBO may terminate this Agreement upon notice without penalty with thirty (30) days prior written notice; *provided*, that in the event Co-Brand Partner exercises its Purchase Option, the Termination Date shall be extended as necessary to match the Purchase Date.

## SECTION 8: INDEPENDENT CONTRACTORS

8.1 Relationship of the Parties. The parties intend for their relationship to be that of independent contractors. Neither party shall be deemed a joint venturer with, or an agent, partner or employee of the other and neither party shall have the power or authority to bind the other.

8.2 Cardholder Notices. Without limiting the generality of the foregoing and except for matters related to the Rewards Program as set forth in Section 2.7 and expressly provided for in Schedule 2.7, Co-Brand Partner acknowledges that Co-Brand Partner has no right or authority to receive on FNBO's behalf notices or other communications (including, without limitation, billing error notices) from Cardholders related to the Accounts. Partner shall promptly forward to FNBO any such notices received by Co-Brand Partner.

## SECTION 9: TERMINATION

9.1 Notice. Either party may terminate this Agreement upon the expiration of the Extension Term or any Renewal Term by giving the other party written notice of termination at least 180 days prior to the end of the Extension Term or any Renewal Term. Subject to survival of obligations as set forth in Section 11.9, all of the parties obligations to each other with respect to Accounts, Compensation and Cardholders shall cease after the termination of this Agreement.

9.2 Breach. In the event that either party materially breaches this Agreement, the non-breaching party may provide notice of the breach to the breaching party, who shall then have 30 days to cure the breach. If the breach is not cured, the non-breaching party may terminate this Agreement effective upon 30 days written notice; *provided*, that if FNBO is the breaching party and Co-Brand Partner desires to exercise its Purchase Option, the Termination Date shall be deferred for such period of time as is reasonably necessary to permit Co-Brand Party to exercise its rights in Schedule 3.7.

9.3 Material Change. If any material change in any federal, state or local law, statute, rule or regulation, or Network requirement makes the continued performance of this Agreement under the then current terms and conditions unduly burdensome to FNBO, FNBO shall have the right to terminate this Agreement upon 90 days advance written notice to Co-Brand Partner. Such written notice shall include a detailed explanation and evidence of the burden imposed as a result of such change.

## SECTION 10: REPRESENTATIONS AND WARRANTIES

10.1 Website Representations and Warranties. Each party represents and warrants that any material, product, information, Mark or data provided or made available by a party or any material presented by a party on any website produced, maintained or published by that party: (a) does not infringe in any manner any copyright, patent, trademark, name, trade secret or any other intellectual property right of any third party; (b) does not contain any material or

information that is obscene, defamatory, libelous or slanderous; (e) does not violate any law or regulation; (d) does not violate or breach any duty toward, or rights of any person or entity, including without limitation, rights or publicity, privacy or personality; and (e) has not resulted in any consumer fraud, product liability, tort, breach of contract, injury, damage or harm of any kind to any person or entity.

10.2 Legal Standing and Contract Authority. Each party represents and warrants that it is a duly incorporated legal entity in good standing and has full power and authority to enter into and perform this Agreement and that there is no contract, agreement, judicial or regulatory order, or understanding with any other person, entity, or corporation which would interfere with the obligations assumed by each party hereunder.

10.3 Laws and Regulations. Each party represents and warrants that the performance by it of its obligations under this Agreement and the Program will not be in material violation of any Applicable Law, rule or regulation and all permits and permissions required to perform such obligations, if any, have been obtained. FNBO shall ensure that the Program shall comply, in all material respects, with all applicable laws, rules and regulations.

10.4 Liability. EXCEPT TO THE EXTENT SUCH DAMAGES ARISE FROM A PARTY'S BREACH OF SECTIONS 7, 2.13, 2.14, 6.3 OR ARE A PART OF A PARTY'S INDEMNIFICATION OBLIGATIONS UNDER THIS SECTION 10, NEITHER PARTY SHALL BE LIABLE FOR SPECIAL, INCIDENTAL, INDIRECT, CONSEQUENTIAL OR EXEMPLARY DAMAGES, REGARDLESS OF WHETHER SUCH PARTY WAS INFORMED OF THEIR POSSIBILITY. EXCEPT AS PROVIDED IN THIS AGREEMENT, NEITHER PARTY ASSUMES ANY RESPONSIBILITY WHATSOEVER WITH RESPECT TO (A) INTERRUPTIONS OR INOPERABILITY OF SUCH PARTY'S WEBSITES OR SYSTEMS; (B) INTERACTION OR INTERCONNECTION OF SUCH PARTY'S WEBSITES OR SYSTEMS WITH THE OTHER PARTY'S WEBSITES OR SYSTEMS; OR (C) UNAUTHORIZED ACCESS TO, OR THEFT, ALTERATION, LOSS OR DESTRUCTION OF THE OTHER PARTY'S WEBSITES OR SYSTEMS, EVEN IF SUCH ACCESS, THEFT, ALTERATION, LOSS OR DESTRUCTION OCCURRED THROUGH THE USE OF SUCH PARTY'S WEBSITES OR SYSTEMS.

10.5 Auditing. (a) Each party shall cooperate with the other party (including its internal audit staff and external auditors, regulators, and other representatives) in the conduct of reasonable audits, assessments, inspections, and monitoring in order to verify performance of this Agreement, which shall include providing reasonable access to facilities, books and records and personnel subject of Applicable Law and audited party's on-site policies and procedures. Such audits shall be conducted only upon at least twenty calendar days' notice and at the audited party's relevant locations during normal business hours at times reasonably convenient for the audited party. An audit shall not unreasonably interfere with the audited party's normal business operations, and the auditing party shall be responsible for its own expenses incurred in connection with the audit. Audit results are Confidential Information of the audited party, and shall be provided to the audited party within a reasonable time after completion of the audit and compilation of the results.

(b) Co-Brand Partner shall notify FNBO upon receiving notice of litigation, regulatory inquiry or complaint with respect to the Program, FNBO, Accounts, Cards, applications, Promotional Materials or any duties performed by Co-Brand Partner pursuant to this Agreement. A scanned copy of such document received by Co-Brand Partner shall accompany each notice and be sent by secure email transmission to FNBO within 48 hours of receipt by Co-Brand Partner. Co-Brand Partner agrees to cooperate with FNBO to the extent necessary for FNBO to adequately respond to such litigation, inquiry or complaint.

(c) Co-Brand Partner acknowledges and agrees that Co-Brand Partner must and shall, at its expense, monitor the activity of each and every Subcontractor in order to ensure that such Subcontractor is complying with Co-Brand Partner's duties, obligations and warranties under the Agreement, as well as FNBO requirements and Applicable Law in the exercise and performance by Subcontractor of any Program related duties, activities, services or responsibilities. Upon request by FNBO from time to time, Co-Brand Partner will provide FNBO with: (i) its policies, procedures and internal controls used with Subcontractors; (ii) the policies, procedures and internal controls used by Subcontractors; (iii) the results of monitoring of Subcontractors; (iv) all audits and monitoring reports of Subcontractors; and (v) any corrective action made to its policies, procedures or internal controls as a result of such monitoring. Co-Brand Partner shall be and will remain liable for all acts and omissions of each and every Subcontractor. Upon written notice from FNBO specifying due cause, Co-Brand Partner shall cease using a Subcontractor as soon as commercially practicable.

#### 10.6 Indemnification.

(a) Co-Brand Partner shall indemnify, defend and hold FNBO harmless from and against any and all Claims by third parties to the extent arising or resulting from: (i) material breach by Co-Brand Partner of any agreement, representation or warranty of Co-Brand Partner contained in this Agreement; (ii) Co-Brand Partner's actual or alleged gross negligence or intentional misconduct related to its duties or obligations under this Agreement; (iii) material violation by Co-Brand Partner of any Applicable Law or Network Rule; (iv) infringement of copyright, trademark, trade secret or other proprietary rights relating to Co-Brand Partner Marks; (v) breach by Co-Brand Partner of its obligations with respect to Confidential Information; (vi) Co-Brand Partner authorizing FNBO to use the Customer Lists or Customer Information as authorized and for the purposes specified herein; (vii) the actions or failure to act of Subcontractors; (viii) duties, obligations and liabilities between Co-Brand Partner and Subcontractors related to duties such Subcontractors are performing under the Program on behalf and at the direction of Co-Brand Partner; (ix) any claims, suits or actions brought against FNBO by Subcontractors with respect to the Program that are not directly attributable to the actions or failures to act by FNBO and (x) breach by Co-Brand Partner of its obligations with regard to the instant issuance of Accounts.

(b) FNBO shall indemnify, defend and hold Co-Brand Partner harmless from and against any and all Claims by third parties to the extent arising or resulting from: (i) material breach by FNBO of any agreement, representation or warranty of FNBO contained in this Agreement; (ii) FNBO's actual or alleged gross negligence or intentional misconduct related to its duties or obligations under this Agreement; (iii) material violation by FNBO of any Applicable Law or Network Rule; (iv) infringement of copyright, trademark, trade secret or other proprietary rights relating to FNBO Marks; (v) breach by FNBO of its obligations with respect to Confidential

Information; (vi) the actions or failure to act of FNBO subcontractors related to duties under the Program provided on behalf and at the direction of FNBO; (vii) any action, suit or demand by a subcontractor or Affiliate of FNBO against Co-Brand Partner that is not directly attributable to the actions or failures to act by Co-Brand Partner; (viii) duties, obligations and liabilities between FNBO and its subcontractors related to duties such subcontractors are performing under the Program on behalf and at the direction of FNBO; (ix) any claims, suits or actions brought against Co-Brand Partner by any subcontractors of FNBO with respect to the Program that are not directly attributable to the actions or failures to act by Co-Brand Partner and (x) breach by FNBO of its obligations with regard to instant issuance of Accounts.

(c) If a party receives notice of any third party Claim for which indemnification or defense may be required under this Agreement, such party shall promptly give written notice to the other party; provided, however, that the failure to provide or a delay in providing such notice shall not relieve the Indemnifying Party of its obligation to indemnify except to the extent the Indemnifying Party is materially prejudiced by such failure or delay. Upon request, the Indemnified Party shall reasonably cooperate with and assist the Indemnifying Party and its counsel in the defense of any Claim and any reasonable direct costs and expenses associated with such cooperation or assistance shall be paid by the Indemnifying Party.

(d) The Indemnifying Party shall pay for and also have the right to assume and control the defense of any third party Claim and shall reasonably defend such Claim with diligence. In the event of an assumption of the defense by the Indemnifying Party, the Indemnified Party shall continue to have the right to employ its own counsel, at its expense. The Indemnifying Party shall not be entitled to settle or compromise any Claim that does not include a full and unconditional release of the Indemnified Party or that imposes obligations on the Indemnified Party except after (i) having fully disclosed to the Indemnified Party the proposed terms and conditions of such settlement or compromise; and (ii) having obtained the Indemnified Party's prior written consent thereto, which consent shall not be unreasonably withheld

10.7 Monitoring. Co-Brand Partner acknowledges and agrees that FNBO must monitor the activity of Co-Brand Partner and each of Co-Brand Partner's employees that interact with Cardholders, Card applicants or potential applicants in connection with the Program ("Sales Employees") with respect to Co-Brand Partner's duties under the Program. Co-Brand Partner agrees to allow reasonable monitoring by FNBO. Co-Brand Partner agrees to use commercially reasonable efforts to monitor its Sales Employees in order to ensure that all such employees are complying with FNBO requirements and Applicable Law in the exercise and performance of Co-Brand Partner's rights and duties under this Agreement, as notified by FNBO to Co-Brand Partner from time to time, including, without limitation, by ensuring that its Sales Employees provide all required disclosures and documentation at the time and in the manner reasonably required by FNBO. Upon request by FNBO from time to time, Co-Brand Partner will provide FNBO with: (a) its policies, procedures and internal controls used with its Sales Employees; (b) the results of monitoring of its Sales Employees; and (c) any corrective action made to its policies, procedures or internal controls as a result of such monitoring.



10.8 Training. Co-Brand Partner agrees to perform its duties under this Agreement and the Program pursuant to the requirements, instructions, training and documentation regarding Applicable Law as provided and directed by FNBO. Co-Brand Partner shall use commercially reasonable efforts to ensure that each Sales Employee or Subcontractor periodically: (a) receives training on all Applicable Laws applicable to Co-Brand Partner's duties and responsibilities under the Program; (b) completes FNBO's applicable training with respect to the services Co-Brand Partner provides under the Program; and (c) is made aware of the applicable Co-Brand Partner responsibilities with respect to the services such Sales Employee or Subcontractor provides on Co-Brand Partner's behalf. Upon request by FNBO from time to time, Co-Brand Partner will provide FNBO with the training materials used by its Sales Employees and Subcontractors and any corrective action made to such training materials as a result of the monitoring required in this Agreement. Co-Brand Partner shall incorporate into its training any requirements of FNBO related to the Cards, Accounts, Promotional Materials or Program.

10.9 Regulatory Authority. Each party acknowledges and agrees that any governmental authority with jurisdiction over a party may examine the other party with respect to such party's duties and responsibilities under this Agreement and the Program. Notwithstanding any other provision of this Agreement, in the event that a governing regulator of FNBO directs FNBO to terminate this Agreement, FNBO may terminate this Agreement without penalty upon 90 days advance written notice to Co-Brand Partner and termination of this Agreement in such event shall not be deemed a breach of this Agreement; *provided*, that to the extent permitted by Applicable Law, the Termination Date may be deferred or delayed as mutually agreed to by the parties to permit Co-Brand Partner to exercise its Purchase Option.

10.10 Suspension of Duties. If FNBO determines in its reasonable discretion that it cannot solicit and originate new Accounts under the Program, FNBO may, upon written notice to Co-Brand Partner, suspend, discontinue or terminate FNBO responsibilities under this Agreement involving the solicitation and origination of new Accounts. Following any such suspension, discontinuance or termination, Co-Brand Partner may terminate this Agreement effective upon 30 days written notice; *provided*, that if Co-Brand Party desires to exercise its Purchase Option, the Termination Date shall be deferred for such period of time as is reasonably necessary for Co-Brand Party to exercise its rights in Schedule 3.7.

## SECTION 11: MISCELLANEOUS

11.1 No Third Party Beneficiaries. This Agreement is for the sole and exclusive benefit of FNBO and the Co-Brand Partner and their respective successors and permitted assigns and nothing in this Agreement shall be construed to grant to any other person any right, remedy, or claim under or in respect of this Agreement, except for FNBO's service providers and as otherwise specifically set forth in this Agreement.

11.2 Amendments. This Agreement may be amended only in a writing signed by both parties.

11.3 Assignments. Neither this Agreement, nor any rights hereunder, may be assigned by either of the parties without the prior written consent of the other party, and such consent may be conditioned upon the assignee's written acknowledgment that assignee shall be bound by the terms and conditions contained herein. FNBO may utilize third parties for its obligations under the Agreement (e.g. printing of Cardholder statements, etc.). Without FNBO's prior express written consent, Co-Brand Partner may not use any Subcontractor in any way related to the

Program. If Co-Brand Partner uses any Subcontractor without FNBO's prior written consent, it shall be deemed a material breach of this Agreement. In the event FNBO provides Co-Brand Partner written consent to use a Subcontractor, Co-Brand Partner may use such Subcontractor only as identified in the written consent; provided, however, that the Subcontractor agrees in writing with Co-Brand Partner to comply with all applicable terms, conditions and provisions of this Agreement and FNBO requirements.

11.4 Binding. This Agreement shall be binding upon, and inure to the benefit of, the parties hereto and their respective heirs, personal representatives, successors and permitted assigns.

11.5 Governing Law. This Agreement shall be governed in all respects by the laws of the State of New York, but shall not include any conflict of law rule that might direct or refer determination of any such matter to the laws of any other jurisdiction.

11.6 Complete Agreement. This Agreement is the complete and exclusive statement of the agreement between the parties relating to the subject matter hereof, which supersedes and merges all prior proposals, understandings, and agreements, oral or written, between the parties relating to the subject matter hereof.

11.7 FNBO Affiliates. Co-Brand Partner agrees that: (a) certain credit card related products and services may be made available by FNBO's Affiliates, which shall be third party beneficiaries of this Agreement with respect to such products; *provided* that neither FNBO nor any FNBO Affiliate shall offer any Cardholder (based on its identity as a Cardholder) any non-Program credit card; and (b) notwithstanding anything to the contrary contained herein, FNBO may assign to any of its Affiliates this Agreement or all or any portion of FNBO's rights or duties under this Agreement; *provided*, for the avoidance of doubt, that such assignment shall not relieve FNBO of its obligations with respect to any such duties.

11.8 Notices. Notices hereunder shall be given in writing by United States registered or certified mail, return receipt requested or overnight courier, addressed to the parties at the addresses set forth below, or such other addresses as the parties may designate in writing from time to time. Notices by overnight courier shall be effective upon actual receipt by the party to be notified.

If to Co-Brand Partner:

MN Airlines, LLC  
1300 Corporate Center Curve  
Eagan, Minnesota 55121  
Attention: General Counsel

If to FNBO:

First National Bank of Omaha  
1620 Dodge Street, Stop Code 3199  
Omaha, Nebraska 68197  
Attention: First Bankcard Legal Dept.

11.9 Survival. Sections 1, 2.3(b), 2.13, 3.3, 3.4, 3.6, 3.7, 6, 7, 10, 11.5, 11.8 and 11.9 shall survive the termination of this Agreement.

11.10 Currency. All references in this Agreement made to currency refer to the lawful currency of the United States of America.

11.11 Insurance. During the Term, each party shall maintain, at its own expense, the following insurance policies covering all its actions in connection with the Program and its rights, obligations, indemnification requirements and liabilities under this Agreement:

(a) Workers' Compensation and Employer's Liability Insurance: (i) Statutory Worker's Compensation benefits or coverage for its employees in amounts no less than the statutory benefits required by Applicable Law; and (ii) Employer's Liability Insurance with minimum limits of \$500,000 per accident for bodily injury by accident, \$500,000 per employee for bodily injury by disease, and \$500,000 for bodily injury by disease;

(b) Commercial General Liability Insurance (including personal injury and contractual liability insurance) providing coverage for bodily injury and property damage and endorsed to include products and completed operations with a minimum combined limit of not less than \$1,000,000 per occurrence and \$2,000,000 in the aggregate;

(c) Employee Dishonesty/Commercial Crime Insurance including third party theft in an amount not less than \$1,000,000; and

(d) Co-Brand Partner shall maintain for the entire duration of the Term Technology and Network Security & Privacy Liability Insurance all providing coverage for FNBO and its customer breach response costs and third party liability, with minimum limits of \$10,000,000.

The insurance policies and coverages that Co-Brand Partner is required to maintain under this Section shall also provide coverage for and include the actions of each Subcontractor, and name FNBO as an additional insured. Each party shall procure its insurance coverages from insurance carriers (i) permitted to do business where required to comply with the requirements of this Section, and (ii) if such carriers are rated by A.M. Best Company, with financial strength, credit and debt rating of at least an A by such company (or equivalent S&P or Moody's financial strength rating). Each party (1) shall, upon request from the other party, provide copies of all current original certificates of insurance evidencing compliance with this Section, and (2) must give the other party at least 30 calendar days prior written notice of any material change, policy cancellation or nonrenewal. In the event applicable coverage is held by both FNBO and Marketing Partner, the insurance held by Co-Brand Partner shall be primary and the insurance held by FNBO shall be secondary. The obligation of a party to provide the insurance coverage specified in this Agreement shall not limit in any way any obligation or liability of such party provided elsewhere in this Agreement.

During the Term, Co-Brand Partner shall ensure that each Subcontractor maintains, at a minimum, all insurance policies and coverages referenced in this Section covering its actions, liabilities and, responsibilities in connection with the Program.

[SIGNATURE PAGE FOLLOWS]

**EXECUTION COPY**

IN WITNESS WHEREOF, the undersigned have executed this Agreement as of the Execution Date.

MN AIRLINES, L.L.C.

FIRST NATIONAL BANK OF OMAHA

By: /s/ Brian Davis  
Name: Brian Davis  
Title: SVP & CMO

By: /s/ Scott Smith  
Name: Scott Smith  
Title: SVP

By: /s/ Jude Bricker  
Name: Jude Bricker  
Title: President and CEO

By: /s/ Amy Bouchard  
Name: Amy Bouchard  
Title: SVP

## REWARDS PROGRAM SCHEDULE TO CO-BRAND MARKETING AGREEMENT

### (SCHEDULE 2.7)

#### **Mandatory Terms:**

1. Earning Points. Each Cardholder enrolled in the Rewards Program shall be eligible to earn:
  - a. 3 Credit Card Rewards Points for every \$1.00 of Qualifying Credit Card Transactions posted to an Account in Good Standing that is spent on Co-Brand Partner's products and services, including purchases made onboard a Co-Brand Partner flight.
  - b. 2 Credit Card Rewards Points for every \$1.00 of Qualifying Credit Card Transactions posted to an Account in Good Standing that is spent with merchants whose merchant code is classified by the payment card industry as: (a) "Service Stations", (b) "Automated Fuel Dispensers" (c) "Grocery Stores and Supermarkets" and (d) "Misc. Food Stores— Convenience Stores and Specialty Markets".
  - c. 1 Credit Card Rewards Point for every \$1.00 of Qualifying Credit Card Transactions posted to an Account in Good Standing that is spent for all other purchases of products and services.
2. Tracking Points. Upon the approval of each Account and the Cardholder's enrollment in the Rewards Program, Co-Brand Partner shall create and maintain a Rewards Account to hold accrued Rewards Points, including Rewards Points reported from FNBO, for such Cardholder. FNBO shall identify and track qualifying purchases using merchant identification numbers and such other relevant information that FNBO may reasonably request Co-Brand Partner provide. FNBO shall have final and sole discretion in determining whether purchases posted to an Account qualify for points. FNBO will track and report to Co-Brand Partner the Credit Card Rewards Points accumulated on each Account on each business day following the close of the Account billing cycle, and each such Credit Card Rewards Point shall automatically be converted by Co-Brand Partner to a Reward Point, which Co-Brand Partner shall credit to each such Cardholder's account under the Rewards Program ("Rewards Account"). In addition, Co-Brand Partner shall track and credit to each Cardholder's Rewards Account not less than 2 Rewards Points for every \$1.00 of Qualifying Credit Card Transactions posted to an Account in Good Standing that is spent on Co-Brand Partner's products and services, including purchases made onboard a Co-Brand Partner flight.

3. **Redemption Value.** The redemption value of Rewards Points shall be determined by Co-Brand Partner in accordance with the terms and conditions of the Rewards Program, unless otherwise denoted in this Agreement, which shall be no less favorable for Cardholders than for other participants in such Rewards Program. Rewards Points will be redeemable in the increments provided under the terms and conditions of the Rewards Program, which redemption increments shall be no less favorable for Cardholders than for other participants in such Rewards Program.
4. **Terms & Conditions.** Co-Brand Partner shall provide to FNBO the most recent terms and conditions of the Rewards Program upon written request, or any time the Rewards Program is amended or modified in any way.
5. **Rewards Program Benefits.** Benefits provided by Co-Brand Partner for each Cardholder meeting the applicable Rewards Program criteria will include, but not be limited to, the following: (a) Spend Bonus as described below; (b) Anniversary Bonus as described below; (c) All checked bags and seat/class upgrades will be discounted by 50% of the regular cost for the Cardholder and for each individual accompanying the Cardholder when booked on the same reservation; (d) One complimentary in flight premium beverage for the Cardholder for every leg of the flight; (e) 48 hour advance notice and bookings on select new routes or destinations that are added to Co-Brand Partner's flight schedule; (f) Priority boarding for the Cardholder and each individual accompanying the Cardholder on all flights; (g) Acquisition Bonus as described below; (h) No foreign transaction fees; and (i) Bonus points on promotional events (e.g., a new hub; a new gateway city).
6. **Funding.** The compensation paid to Co-Brand Partner under the Compensation Schedule for Account Activation Bonus Payments for Consumer Accounts shall be applied by Co-Brand Partner to fund the Rewards Program for Activated Card Cardholders. Notwithstanding any other terms and conditions related to the redemption value for the Rewards Program, each Rewards Point redeemed by Cardholders on a Consumer Account that is Activated shall be valued at \$0.01 (one cent) per point.
7. **Anniversary Bonus.** (a) For Cardholders whose applications were received on or after July 28, 2016: 10,000 Rewards Points redeemable for Co-Brand Partner products and services at the end of any Qualification Period in which all of the following occur: (1) the Account is enrolled in the Rewards Program for the entire Qualification Period; (2) at least \$10,000 in Qualifying Credit Card Transactions is posted to the Account during the Qualification Period; and (3) the Account is in good standing per FNBO records. (b) For Cardholders whose applications were received before July 28, 2016: 5,000 Rewards Points redeemable for Co-Brand Partner products and services at the end of any Qualification Period in which all of the following occur: (1) the Account is enrolled in the Rewards Program for the entire Qualification Period; (2) at least \$10,000 in Qualifying Credit Card Transactions is posted to the Account during the Qualification Period; and (3) the Account is in good standing per FNBO records.

8. Definitions. For the purposes of this Schedule 2.7: “Qualification Period” means each period of 12 complete, consecutive Billing Cycles occurring immediately prior to the renewal date of a Card; “Qualifying Credit Card Transactions” means authorized new purchases posted to the Account on or after the Cardholder’s date of enrollment in the Rewards Program, net of refunds, credits and disputed billing items but “Qualifying Credit Card Transactions” do not include: (a) annual fees, finance charges and other fees or charges posted to Accounts; (b) cash advances or the use of convenience checks; (c) balance transfers; (d) charges for other products, services or benefits provided by FNBO; or (e) other transactions reasonably determined by FNBO not to be eligible; “Billing Cycles” means the interval between the days or dates of the periodic statements for the Account regardless of whether a periodic statement was generated.
9. Acquisition Bonus. For Accounts opened and Activated on or after January 2, 2019, Cardholders shall earn a one-time acquisition bonus of 20,000 Rewards Points redeemable at any time for Co-Brand Partner products and services when all of the following occur: (a) the Account is enrolled in the Rewards Program; (b) at least \$1,500 in Qualifying Credit Card Transactions are posted to the Account during the first 3 Billing Cycles after the account is opened; and (c) the account is in good standing per FNBO records.

Discretionary Terms:

If any discretionary terms are proposed by Co-Brand Partner, except to the extent those terms do not require FNBO to undertake additional obligations or activities with respect to the Rewards Program (including tracking information), such proposed discretionary terms must be agreed upon by FNBO to become obligations under the Reward Program.

**Administration of Rewards Program:**

1. The parties agree that Accounts established pursuant to this Agreement shall be eligible to earn Rewards Points redeemable through the Rewards Program. Co-Brand Partner will fund and be liable for the redemption of all points earned on the Accounts and shall administer the Rewards Program at its own expense. FNBO shall have no obligation to fund or administer the Rewards Program.
2. Accounts will earn and accumulate Credit Card Rewards Points as specified in the Mandatory Terms. FNBO will track such Credit Card Rewards Points from both Co-Brand Partner and non-Co-Brand Partner purchases and, subject to Applicable Law, report (in a manner mutually agreed to by the parties), accrued Credit Card Rewards Points information on an Account-basis to Co-Brand Partner at the completion of each billing cycle. Upon receipt of such information, Co-Brand Partner will promptly convert the Credit Card Rewards Points into Rewards Points and make such Rewards Points available for redemption by the Cardholders of such Accounts in accordance with the terms and conditions of the Rewards Program.

3. For each Credit Card Rewards Point that FNBO reports to Co-Brand Partner for a Cardholder, Co-Brand Partner shall make 1 Rewards Point available for redemption by that Cardholder in the Rewards Program. In addition, Co-Brand Partner shall track and credit to each Cardholder's Rewards Account not less than 2 Rewards Points for every \$1.00 of Qualifying Credit Card Transactions posted to an Account in Good Standing that is spent on Co-Brand Partner's products and services, including purchases made onboard a Co-Brand Partner flight. FNBO hereby acknowledges that Co-Brand Partner intends to market the Program as 5 Rewards Points for each dollar spent on Co-Brand Partner's products and services, which will consist of 3 Credit Card Reward Points (converted to Reward Points upon being reported to Co-Brand Partner by FNBO) and the 2 Reward Points specified in the foregoing sentence. FNBO agrees that such marketing, so long as Co-Brand Partner operates the Rewards Program consistently in strict conformity and in accordance with such marketing, shall not constitute UDAAP.
4. Rewards Points earned by the Cardholder in the Rewards Program shall not expire as long as the Account is open and in Good Standing per FNBO records.
5. Upon the termination or expiration of this Agreement for any reason, Accounts will no longer be eligible to earn and accumulate Credit Card Rewards Points. Notwithstanding the termination or expiration of this Agreement, Co-Brand Partner shall continue to honor all Rewards Points validly credited to Accounts prior to the effective date of such termination or expiration in a manner consistent with the treatment of all Rewards Points earned in the Rewards Program during the Term of this Agreement.



**PURCHASE OPTION SCHEDULE  
(SCHEDULE 3.7)**

1. Definitions. For purposes of this Schedule and the Agreement, the following terms shall have the meanings assigned to them below:

“**Alternative Nominated Purchaser**” shall have the meaning provided in Section 6 of this Schedule 3.7

“**Conversion Data**” has the meaning provided in Section 3 of this Schedule 3.7.

“**Evaluation Notice**” has the meaning provided in Section 2 of this Schedule 3.7.

“**Fair Market Value**” means the amount mutually agreed upon by the parties, expressed as a percentage of the Receivables or, if no amount can be agreed upon by the parties, then the Fair Market Value shall be determined pursuant to Section of this Purchase Option Schedule.

“**KPI**” means market standard key performance indicators related to the performance of the Card portfolio.

“**Nominated Purchaser**” means the credit card issuer designated by Co-Brand Partner to exercise the Purchase Option provided that such credit card issuer is legally and contractually able to purchase the Program Assets.

“**Option Period**” means the period commencing (a) with the effectiveness of a notice of termination provided by either FNBO or Co-Brand Partner pursuant to Section 9.1 of the Agreement or (b) with the effectiveness of any other notice of termination other than a notice of termination provided by FNBO pursuant to Section 9.2 and ending (i) in the case of a notice of termination contemplated in the foregoing clause (a) provided by Co-Brand Partner, 30 calendar days thereafter, (ii) in the case of a notice of termination contemplated in the foregoing clause (a) provided by FNBO, 90 calendar days after the later of the effective date of such notice or the date FNBO delivers RFP Data to Co-Brand Partner, or (iii) in the case of a notice of termination contemplated in the foregoing clause (b), the earlier of 60 calendar days after the effective date of such notice or the Termination Date of the Agreement set forth in such notice.

“**Program Assets**” means all of the Accounts, as well as their related Receivables, Cardholder Information, Account documentation and other rights, and such other Program data reasonably necessary to enable continuing operation and management of the Accounts, *less* accounts (and their related receivables) excluded for customary reasons including, but not limited to, fraud, lost/stolen, deceased, bankruptcy, delinquent more than 29 days, charged-off status, or as mutually agreed to by the parties.

“**Purchase Agreement**” means the agreement between FNBO and the Co-Brand Partner (or the Nominated Purchaser, as applicable) for the purchase of the Program Assets containing the terms and conditions set forth below and such other terms as mutually agreed to between the parties.

“**Purchase Date**” means the closing date for the purchase of the Program Assets.

“**Purchase Notice**” means written notice from Co-Brand Partner to FNBO of Co-Brand Partner’s intent to exercise the Purchase Option given during the Option Period.

“**Purchase Option**” means the nontransferable one-time right (except with respect to a Nominated Purchaser as provided herein) of Co-Brand Partner to purchase the Program Assets from FNBO in exchange for the Fair Market Value.

“**Receivable**” means, with respect to an Account as of the date or time in question, all amounts owed on such Account by the Cardholder, including outstanding purchases, cash advances, billed finance charges and any other charges and fees assessed on the Account, less all adjustments, credits, credits related to disputed amounts, and (without duplication) credit balances owed to the Cardholders on such Account.

“**RFP Data**” has the meaning provided in Section 2 of this Schedule 3.7.

2. Portfolio Evaluation. Not earlier than twenty-four (24) months prior to the expiration of this Agreement, Co-Brand Partner may notify FNBO in writing of Co-Brand Partner’s intent to evaluate the Card portfolio (the “**Evaluation Notice**”). An Evaluation Notice may also be delivered by Co-Brand Partner within thirty (30) days following a notice by either FNBO or Co-Brand Partner of a termination which will trigger the Purchase Option pursuant to Section 3.7. Within fifteen (15) business days following the timely issuance of an Evaluation Notice, FNBO shall provide Co-Brand Partner with aggregate portfolio level information for Co-Brand Partner to include in an RFP for the purpose of permitting Networks to evaluate, and potential purchasers to adequately determine their interest in bidding upon, the Card portfolio (the “**RFP Data**”). Such RFP Data shall include aggregate portfolio level information and KPI’s for the previous two (2) years broken out by year. If more than one potential purchaser requests additional information regarding the Card portfolio customary for this type of transaction, FNBO will provide to Co-Brand Partner such additional information in a timely manner. Prior to any RFP Data or other information being provided pursuant to this Section 2, FNBO shall be entitled to require any potential purchaser and such potential purchaser’s advisors and representatives to enter into commercially reasonable confidentiality arrangements with FNBO that covers the RFP Data and other information supplied by FNBO under this Section 2. Such confidentiality arrangements shall be substantially as protective as the confidentiality provisions set forth in Section 7 of the Agreement.

3. Conversion Data. Within thirty (30) days of request following the designation of the Nominated Purchaser and mutual agreement in writing of all parties on the price of the Portfolio, FNBO shall provide customary “data room” documentation, and such other Account data, information and interviews with FNBO, on-site due diligence and access to FNBO management, as may be reasonably requested by Co-Brand Partner (collectively, the “**Conversion Data**”). Co-Brand Partner may share the Conversion Data provided to Co-Brand Partner under this Section 3 with Co-Brand Partner advisors and representatives and the Nominated Purchaser and their advisors and representatives to facilitate the purchase and conversion of the Accounts; *provided, however*, that such advisors are obligated to maintain the confidentiality of the information they receive. Notwithstanding the foregoing, FNBO may in its sole discretion also require that Co-Brand Partner cause its advisors and representatives, and the Nominated Purchaser, Alternative Nominated Purchaser and their advisors and representatives, to enter into

confidentiality agreements and arrangement with FNBO that covers the Conversion Data and other information supplied by FNBO under this Schedule 3.7 before providing such Conversion Data, which confidentiality agreements and arrangements shall be substantially as protective as the confidentiality provisions set forth in Section 7 of the Agreement. If the Nominated Purchaser and Alternative Nominated Purchaser has previously entered into confidentiality agreements and arrangements with FNBO pursuant to this Schedule 3.7, Co-Brand Partner shall cause such Nominated Purchaser and Alternative Nominated Purchaser and such Nominated Purchaser's and Alternative Nominated Purchaser's advisors and representatives to enter into confidentiality agreements and arrangements with FNBO that covers the Conversion Data and other information supplied by FNBO under this Schedule 3.7 before providing such Conversion Data, which confidentiality agreements and arrangements shall be substantially as protective as the confidentiality provisions set forth in Section 7 of the Agreement.

4. Purchase Option Exercise. So long as Co-Brand Partner is not at the time in material breach of the Agreement, it may exercise its Purchase Option by providing FNBO the Purchase Notice prior to the expiration of the Option Period. Co-Brand Partner may only exercise its Purchase Option one-time. The completion of the Purchase following the exercise of the Purchase Option shall require the execution of a mutually agreeable Purchase Agreement between FNBO and Co-Brand Partner (or the Nominated Purchaser or Alternative Nominated Purchaser) for a purchase price of at least the Fair Market Value, all as provided in Sections 5 and 6 of this Schedule 3.7. Simultaneously with the closing of the Purchase Agreement, this Agreement shall be terminated. Following delivery of the Purchase Notice, FNBO and Co-Brand Partner (or the Nominated Purchaser, as applicable) will negotiate a mutually agreeable market standard Purchase Agreement between for a purchase price equal to the Fair Market Value. The Purchase Agreement will specify the Purchase Date, which shall be the Termination Date, unless otherwise mutually agreed upon by the parties, *provided, however*, that in the event the Option Period commences pursuant to clause (b) of the definition thereof, the Purchase Date shall be 90 calendar days after the designation of the Nominated Purchaser, unless otherwise mutually agreed upon by the parties. Notwithstanding anything in the Agreement to the contrary, in the event that Co-Brand Partner exercises the Purchase Option, to the extent necessary the Term of the Agreement shall be extended until the Purchase Date.

5. Determination of Fair Market Value. Upon receipt of the Purchase Notice, Co-Brand Partner (or the Nominated Purchaser, as applicable) and FNBO shall enter into good faith negotiations for a period not to exceed 25 calendar days to determine the Fair Market Value of the Program Assets. In the event the parties are not able to agree on the Fair Market Value within such 25 calendar day period, then FNBO (at its expense) and Co-Brand Partner (at its expense) shall each retain an independent appraisal firm of national standing within 15 calendar days following the conclusion of such 25 calendar day period. FNBO shall provide identical sets of information to the appraisers as is necessary to permit the appraisers to provide a valuation of the Program Assets. Each appraisal firm shall provide its appraisal, expressed as a percentage of the Receivables, to both parties within 30 calendar days from the date of engagement. If the difference between the appraisals provided by the two firms is not greater than 300 basis points, then the Fair Market Value shall be the average of the two appraisals (i.e., if the appraisals are 115% and 118%, respectively, then the difference between the appraisals would be 300 basis points and the Fair Market Value would be 116.5%, the average of the two appraisals). If the difference between the appraisals provided by the two firms is greater than 300 basis points, then

the two appraisal firms shall hire a third appraisal firm (the expense of which will be shared equally by Co-Brand Partner and FNBO) within 5 calendar days from the date the last appraisal was provided to the parties, and the third appraisal firm shall provide its appraisal within 15 calendar days from the date of engagement and the Fair Market Value shall be the median of the three appraisals.

6. Purchase Agreement. The Purchase Agreement shall, among other things, include the following terms: (a) a sale by FNBO without recourse as to credit liability and collectability (but with standard indemnities for misrepresentations and breaches of warranties and covenants); (b) standard representations, warranties and covenants for credit card portfolio purchase agreements; (c) Card plastics issued by FNBO will be replaced with plastics issued by Co-Brand Partner (or the Nominated Purchaser or Alternative Nominated Purchaser, as applicable) upon earlier of the scheduled expiration of each Card or 180 days after the Purchase Date; (d) the assumption by Co-Brand Partner (or the Nominated Purchaser or Alternative Nominated Purchaser, as applicable), as of the Purchase Date, of all of FNBO's obligations and liabilities with respect to the Program Assets; (e) either (i) the conversion of the Program Assets to Co-Brand Partner's platform, Nominated Purchaser's (or Alternative Nominated Purchaser's) platform or a third party servicer's platform on the Purchase Date, or (ii) if conversion is not feasible on the Purchase Date, an interim servicing period pursuant to an interim servicing agreement to be negotiated between FNBO and Co-Brand Partner (or the Nominated Purchaser, or Alternative Nominated Purchaser as applicable) wherein Co-Brand Partner and/or the Nominated Purchaser or Alternative Nominated Purchaser agree to bear the costs associated with such interim servicing; (f) Co-Brand Partner shall be responsible for and promptly reimburse FNBO for the reasonable and customary costs and expenses (including third party costs and expenses) associated with the conversion of the Program Assets. In the event FNBO and the Nominated Purchaser initially designated by the Co-Brand Partner are unable to agree on the terms and conditions of a Purchase Agreement, Co-Brand Partner may designate another credit card issuer provided that such credit card issuer is legally and contractually able to purchase the Program Assets ("Alternative Nominated Purchaser"). In this event both parties agree that: (a) the Alternative Nominated Purchaser shall complete all due diligence activities based on the due diligence materials produced for the original Nominated Purchaser; and (b) if Fair Market Value was established during negotiations with the Nominated Purchaser pursuant to the appraisal process described in Section 5 of this Schedule 3.7, such Fair Market Value shall be binding on the Alternative Nominated Purchaser. If FNBO and the Alternative Nominated Purchaser are also unable to reach agreement on the terms and conditions of a Purchase Agreement, this Agreement shall terminate and FNBO shall have no further obligation with respect to the sale of the Program Assets.

7. Fair Market Value Assumptions. In determining the Fair Market Value, the appraisal firms shall assume the following: (a) all of the Accounts that comprise the Program Assets shall be purchased; (b) value the Program Assets as a going concern, subject to a new five year joint marketing agreement of the existing Program with a credit card issuer willing to extend credit to the same credit population segment and include the residual value of the portfolio after the endorsement expires; (c) the economics of the Program between the Co-Brand Partner and the credit card issuer remains the same as delineated in this Agreement (including any then-existing value proposition, compensation, funding as provided by the parties, Program revenue, rewards program funding and incentives) shall remain in effect for the duration of the five year joint

marketing agreement; (d) the level of support from Co-Brand Partner remains at the same level as required under this Agreement for the duration of the five year joint marketing agreement; (e) assume the economics of the program between Co-Brand Partner and the credit card issuer remains the same using the direct costs associated with the Program but excluding the indirect costs for the duration of the five year joint marketing agreement; (f) operating expenses will be industry standard marginal servicing costs for a credit card portfolio; and (g) that Program interchange revenue and marketing support from the Network(s) remains at the same level as of the commencement of the Option Period for the duration of the five year joint marketing agreement. The appraisal firms shall also consider historical performance of the portfolio while also considering market and portfolio trends.

8. Costs and Expenses. Except as otherwise provided in this Purchase Option Schedule, each party shall bear all of its own direct and indirect costs and expenses in connection with the negotiation of the Purchase Agreement (and an interim servicing agreement, if necessary).

## SCHEDULE 5.1

### COMPENSATION SCHEDULE TO CO-BRAND MARKETING AGREEMENT

1. Finder's Fees for New Accounts

- FNBO will pay Co-Brand Partner an initial, one-time finder's fee of \$75.00 for each Activated Application Account.
- FNBO will pay Co-Brand Partner an initial, one-time finder's fee of \$5.00 for each Activated Solicitation Account.

2. Account Activation Bonus Payments

- FNBO shall pay Co-Brand Partner a one-time \$100 bonus payment for each Activated Application Account when all of the following occur: (a) at least \$1,500 in Qualified Credit Card Transactions are posted to the Account during the first 3 Billing Cycles after the Account is opened; and (b) the account is in Good Standing per FNBO records. Co-Brand Partner shall use such bonus payments to fund the Mandatory Terms of the Rewards Program in Schedule 2.7.
- FNBO shall pay Co-Brand Partner a one-time \$75 bonus payment for each Activated Solicitation Account when all of the following occur: (a) at least \$1,500 in Qualified Credit Card Transactions are posted to the Account during the first 3 Billing Cycles after the Account is opened; and (b) the account is in Good Standing per FNBO records. Co-Brand Partner shall use such bonus payments to fund the Mandatory Terms of the Rewards Program in Schedule 2.7.

3. Renewal Fees

- FNBO will pay Co-Brand Partner a renewal fee of \$1.00 for each Activated Account in Good Standing (a) on that Account's first anniversary date; (b) and each anniversary date thereafter.

4. Net Retail Compensation

- FNBO shall pay Co-Brand Partner 3.00% of Net Retail Sales posted to Activated Accounts in Good Standing that is spent on Co-Brand Partner's products and services, including purchases made onboard a Co-Brand Partner flight;
- FNBO shall pay Co-Brand Partner 2.00% of Net Retail Sales posted to Activated Accounts in Good Standing that is spent on products and services at grocery stores or gas stations; and
- FNBO shall pay Co-Brand Partner 1.78% of Net Retail Sales posted to Activated Accounts in Good Standing that is spent for all other purchases of products and services.

For clarification, Co-Brand Partner shall use 1.00% of the Net Retail Compensation it receives herein to fund the Mandatory Terms of the Rewards Program in Schedule 2.7.

5. Acquisition Bonus Cost Sharing.

- From time to time, the parties may agree to an Acquisition Bonus that may be greater than the base Acquisition Bonus of 20,000 Rewards Points outlined in Section 9 of the Mandatory Terms of the Rewards Program in Schedule 2.7 for each Account opened and Activated on or after January 2, 2019. In such an event, FNBO shall pay Co-Brand Partner \$ 0.005 per point for each Acquisition Bonus Rewards Point credited to the Cardholder's Account over and above the base Acquisition Bonus of 20,000 Rewards Points outlined in Section 10 of the Mandatory Terms of the Rewards Program in Schedule 2.7.

**AMENDMENT NO. 1 TO  
AMENDED AND RESTATED CO-BRAND MARKETING AGREEMENT**

**THIS AMENDMENT NUMBER 1 TO THE AMENDED AND RESTATED CO-BRAND MARKETING AGREEMENT** (this “**Amendment**”), dated as of November 1, 2018 (“**Effective Date**”), is made and entered into by and between **FIRST NATIONAL BANK OF OMAHA** (“**FNBO**”) and **MN AIRLINES LLC d/b/a SUN COUNTRY AIRLINES** (“**Co-Brand Partner**”).

**RECITALS:**

WHEREAS, FNBO and Co-Brand Partner are parties to that certain Amended and Restated Co-Brand Marketing Agreement dated October 17, 2018 (the “**Agreement**”).

WHEREAS, the parties have agreed to make changes to the Agreement that are outlined below.

NOW, THEREFORE, in consideration of the foregoing and the mutual covenants and agreements hereinafter set forth, and for other good and valuable consideration, the receipt and sufficiency of which is hereby acknowledged, the parties agree as follows:

1. Definitions. Capitalized terms used in this Amendment but not otherwise defined herein shall have the meanings ascribed to such terms in the Agreement. The terms and expressions “this Agreement,” “this document,” “herein,” and other terms and expressions of similar import in the Agreement are hereby amended to mean the Agreement as amended by this Amendment.

2. The definition of Good Standing in Section 1 (“Definitions”) is deleted in its entirety and replaced with the following:

“**Good Standing**” means with respect to an Account, that as of the date of such determination all payments are current, charge privileges have not been revoked or suspended, the credit limit is not exceeded, had a balance greater than \$0.00 during the last six billing cycles or on which finance charges have been billed during the last six billing cycles, and all other requirements of the applicable Cardmember Agreement have been complied with as of the applicable date.

3. Section 4 of the Compensation Schedule to Co-Brand Marketing Agreement ( Schedule 5.1) of the Agreement is deleted in its entirety and replaced with the following:

4. Net Retail Compensation.

- FNBO shall pay Co-Brand Partner 3.00% of Net Retail Sales that is spent on Co-Brand Partner’s products and services, including purchases made onboard a Co-Brand Partner flight;

**18-4490 Amendment 1 to the Amended and Restated Co-Brand Marketing Agreement for Sun Country Airlines 11/2018 SS**



- FNBO shall pay Co-Brand Partner 2.00% of Net Retail Sales that is spent on products and services at grocery stores or gas stations; and
  - FNBO shall pay Co-Brand Partner 1.78% of Net Retail Sales that is spent for all other purchases of products and services.  
For clarification, Co-Brand Partner shall use 1.00% of the Net Retail Compensation it receives herein to fund the Mandatory Terms of the Rewards Program in Schedule 2.7
4. Section 2 of the Compensation Schedule to Co-Brand Marketing Agreement (Schedule 5.1) of the Agreement is deleted in its entirety and replaced with the following:
2. Account Activation Bonus Payments.
- FNBO shall pay Co-Brand Partner a one-time \$100 bonus payment for each Activated Application Account when at least \$1,500 in Qualified Credit Card Transactions are posted to the Account during the first 3 Billing Cycles after the Account is opened. Co- Brand Partner shall use such bonus payments to fund the Mandatory Terms of the Rewards Program in Schedule 2.7
  - FNBO shall pay Co-Brand Partner a one-time \$75 bonus payment for each Activated Solicitation Account when at least \$1,500 in Qualified Credit Card Transactions are posted to the Account during the first 3 Billing Cycles after the Account is opened. Co- Brand Partner shall use such bonus payments to fund the Mandatory Terms of the Rewards Program in Schedule 2.7
5. Section 3 of the Compensation Schedule to Co-Brand Marketing Agreement (Schedule 5.1) of the Agreement is deleted in its entirety and replaced with the following:
3. Renewal Fees
- FNBO will pay Co-Brand Partner a renewal fee of \$1.00 for each open Account in Good Standing (a) on that Account's first anniversary date; (b) and each anniversary date thereafter.
6. Section 5 of the Mandatory Terms of the Rewards Program Schedule to Co-Brand Marketing Agreement (Schedule 2.7) of the Agreement is deleted in its entirety and replaced with the following:
- 5 Rewards Program Benefits. Benefits provided by Co-Brand Partner for each Cardholder meeting the applicable Rewards Program criteria will include, but not be limited to, the following: (a) Spend

Bonus as described below; (b) Anniversary Bonus as described below; (c) all seat selection fees and the cost of the first bag (either a checked bag or a carry-on) will be discounted by 50% of the regular cost for the Cardholder, and for each individual accompanying the Cardholder when booked on the same reservation, if purchased either online at [suncountry.com](http://suncountry.com) or via Co-Brand Partner's customer service inbound call line; (d) One complimentary inflight premium beverage for the Cardholder for every leg of the flight; (e) 48 hour advance notice and bookings on select new routes or destinations that are added to Co-Brand Partner's flight schedule; (f) Priority boarding for the Cardholder and each individual accompanying the Cardholder on all flights; (g) Acquisition Bonus as described below; (h) No foreign transaction fees; and (i) Bonus points on promotional events (e.g., a new hub; a new gateway city).

7. Section 1(b) of the Mandatory Terms of the Rewards Program Schedule to Co-Brand Marketing Agreement (Schedule 2.7) of the Agreement is deleted in its entirety and replaced with the following:

- b. 2 Credit Card Rewards Points for every \$1.00 of Qualifying Credit Card Transactions posted to an Account in Good Standing that is spent with merchants whose merchant code is classified by the payment card industry as: (a) "Service Stations", (b) "Automated Fuel Dispensers" (c) "Grocery Stores and Supermarkets" (d) "Misc. Food Stores— Convenience Stores and Specialty Markets" (e) "Dairy Products Stores", (f) "Bakeries", (g) "Freezer and Locker Meat Provisioners", (h) "Candy Nut and Confectionary Stores", and (i) "Package Stores – Beer, Wine, and Liquor".

8. Miscellaneous. This Amendment, together with the Agreement and its attachments, exhibits and schedules, constitute the entire agreement between the parties with respect to the subject matter hereof and thereof. Except as expressly modified by this Amendment, all other terms and conditions set forth in the Agreement shall remain unchanged and in full force and effect and are hereby ratified and confirmed. This Amendment may be executed in counterparts and transmitted by facsimile copy, each of which shall constitute an original and which taken together shall constitute the Amendment. Facsimile or electronically scanned signatures on this Amendment shall for all purposes be treated as if manually signed by the party whose facsimile or electronically scanned signature appears. In the event of a conflict between the terms of this Amendment and the terms of the Agreement, the terms of this Amendment shall control.

[REMAINDER OF PAGE LEFT INTENTIONALLY BLANK— SIGNATURE PAGE FOLLOWS]

**18-4490 Amendment 1 to the Amended and Restated Co-Brand Marketing Agreement for Sun Country Airlines 11/2018 SS**

IN WITNESS WHEREOF, the parties hereto have executed this Amendment as of the Effective Date.

**MN AIRLINES LLC d/b/a SUN  
COUNTRY AIRLINES**

By: /s/ Brian Davis  
Name: Brian Davis  
Title: SVP & CMO

**FIRST NATIONAL BANK OF OMAHA**

By: /s/ Scott Smith  
Name: Scott Smith  
Title: SVP

AND

By: /s/ Jude Bricker  
Name: Jude Bricker  
Title: President and CEO

By: /s/ Amy Bouchard  
Name: Amy Bouchard  
Title: Sr. Vice President, Finance

**18-4490 Amendment 1 to the Amended and Restated Co-Brand Marketing Agreement for Sun Country Airlines 11/2018 SS**

*INVENTORY SUPPORT & SERVICES*

*AGREEMENT*

*Between*

*MN AIRLINES, LLC*

*And*

*DELTA AIRLINES, INC.*

*MN Airlines Inventory Support Agreement 8 Oct 2003*

This Inventory Support and Services Agreement (“Agreement”) dated as of October 27, 2003 by and between Delta Air Lines, Inc., a Delaware corporation with its principal office at Hartsfield Atlanta International Airport, Atlanta, Georgia (Delta) and MN Airlines, LLC a Limited Liability Corporation organized under the laws of Minnesota with its principal office at 1300 Mendota Heights Road, Mendota Heights, MN 55120 (“MN Airlines”).

WITNESSETH

WHEREAS, MN Airlines operates certain Boeing 737-NG aircraft powered by CFM 56-7 engines (the “Aircraft”) as further described in Annex A1 hereto; and

WHEREAS, MN Airlines desires for Delta to provide certain aircraft inventory support services for the Aircraft as further defined in Annex A to this Agreement (the “Services”); and

WHEREAS, Delta agrees to perform such Services in accordance with the terms and conditions of this Agreement, including all Annexes incorporated herein by reference.

NOW, THEREFORE, in consideration of the mutual covenants contained herein, the parties hereby agree as follows:

**1. DESCRIPTION OF THE SERVICES**

1.1 Subject to the terms and conditions set forth in this Agreement, Delta agrees to provide to MN Airlines, in accordance with the performance measures set forth in Annex A hereto, inventory support and component maintenance for Common Components (“Components”) for MN Airlines Aircraft as more specifically identified in the Annexes hereto. Delta shall be the exclusive provider of such Services during the Term of this Agreement with the exceptions noted in the Supply Response Times section of Annex A. Should MN Airlines sub-lease or discontinue operation of any of the Aircraft, that particular aircraft shall be deemed to have been removed from this inventory support program. Such aircraft may be eligible for return to this program using the program rates vs aircraft age table in Annex A2, Charges & Payments.

1.2 MN Airlines will provide to Delta, or provide Delta access to, as required and as available, any and all manufacturer-issued manuals, drawings, test equipment, software upgrades and data and revisions thereto and any related logs and records and any and all other technical data not available to Delta (hereinafter referred to as “Data”) which is in the possession or control of MN Airlines and which may be required by Delta for completion of the Services and related record keeping responsibilities at the location where any Service is to be performed prior to commencement of such Service. This includes all manuals, data, drawings and revisions thereto produced by any subcontractor, vendor and other supplier. These will be supplied to Delta in English and in a format, either paper, film or electronic, usable by Delta with its present equipment. Delta agrees to execute a contractor

confidentiality agreement or other such similar agreement as deemed necessary to comply with the contract performance requirements herein, at the reasonable request of MN Airlines' suppliers or vendors.

1.3 Standards and Practices, Regulatory Requirements - Delta will perform all work in accordance with the regulations set forth in FAR Part 43 & 121 as authorized under its FAR 121 Air Carrier Certificate, No. DALA026A. Services will be performed in accordance with Delta's Continuous Airworthiness Maintenance Program and Manuals.

**2. TERM & TERMINATION**

2.1 This Agreement shall become effective on the date first written above (the "Effective Date") and, unless terminated earlier as provided for herein, shall remain in force and effect for ten (10) years from such Effective Date (the "Term"). Except in the case of a termination for cause by either party, any Services in progress upon the termination or expiration of this Agreement or any Annex hereof, shall be completed and any payments due therefore shall be made in accordance with the terms hereof, even if the period required to complete such Services extends beyond the date of termination or expiration of this Agreement

2.2 At any time after five (5) years from the Effective Date, either party may terminate this Agreement for convenience and without penalty or further obligation to the other party upon not less than one hundred eighty (180) days prior written notice to the other party.

2.3 The above notwithstanding, either party may terminate this Agreement upon breach or default by the other party of the terms of this Agreement or of any other agreement between the parties which breach or default is not cured (i) within ten (10) days after receipt of written notice of any payment default, or (ii) within thirty (30) days after receipt of written notice of any other default; provided, however, if any default other than a payment default is not capable of cure within thirty (30) days, then such longer period as may be required to effect a cure provided the party is diligently and actively pursuing a cure.

**3. CHARGES AND PAYMENT**

3.1 In consideration of the Services to be provided hereunder, Delta will charge MN Airlines and MN Airlines agrees to pay to Delta those charges appearing in the Annex A2 hereto. All amounts shown and all payments due under this Agreement are in United States Dollars. All amounts will be invoiced to MN Airlines and settled through direct billing unless otherwise mutually agreed to, in writing, between the parties. All charges shown in Annexes hereto shall be subject to escalation in accordance with the escalation formula listed in Annex A3 to this Agreement.

3.2 MN Airlines will pre-pay all invoices. MN Airlines may chose a payment plan to pay all invoiced within thirty (30) calendar days from the date of such invoice, however Delta may require a Letter of Credit in an amount to be determined by Delta. MN Airlines shall make all

payments to Delta by wire transfer (MN Airlines to bear the expense of the wire charges) to Citibank, N.A., 399 Park Avenue, New York, New York, ABA number 021000089, account number 30453617, with a request that the bank advise Delta by telephone at 404-714-2606 upon receipt of the funds. Should an amount due to Delta by MN Airlines not be paid by its due date, MN Airlines will pay a late charge equal to the lesser of 1.5% per month or the maximum rate permitted by applicable law from and after the due date until the unpaid balance and any accrued interest is paid in full ("Past Due Rate").

3.3 Any and all sales, use, value added, excise, goods and services or other taxes (excluding any tax upon the income or gross receipts of Delta), assessments, fees, duties or other charges imposed or which may be imposed by any federal, state, county or local taxing or other authority on the provision or sale of services, parts, materials or articles to MN Airlines supplied under this Agreement ("Taxes") for which Delta may be held responsible for the collection or payment on its own behalf or on behalf of MN Airlines will be the sole and exclusive responsibility of and will be payable exclusively by MN Airlines.

3.4 All amounts charged hereunder are exclusive of such Taxes and charges. Delta's failure to invoice or collect such taxes and charges from MN Airlines will not be deemed a waiver or release of MN Airlines obligations hereunder, if any. MN Airlines further agrees to indemnify and hold Delta harmless from and against the payment of those Taxes referred to in Section 3.3 of this Agreement. In addition, MN Airlines agrees to repay the interest and penalties that may accrue or are otherwise incurred in connection with the Services. If a claim is made against any party for Taxes with respect to which the other party is liable for a payment or indemnity hereunder, the party receiving such claim will promptly give the other notice in writing within fifteen (15) days of receipt of such claim; provided, however, that failure to give notice will not relieve any party of its obligations hereunder; provided, however, that the party which fails to give timely notice of the assessment of any Tax shall be responsible for any interest and penalties relating to or arising from the late payment of such Tax. MN Airlines will be required to remit payment to Delta or the tax authority, as appropriate, unless MN Airlines is permitted by applicable law to contest such claim and defer payment in accordance with the law. Such contest will be coordinated by Delta and the reasonable expenses will be borne by MN Airlines, and includes, but is not limited to such costs, expenses, legal and accounting fees, penalties and interest. If either party receives any refund on account of any suit or action for a Tax for which the other party has provided funds hereunder, such party shall promptly, but in any event within thirty (30) days of receipt of such refund, remit such refund to the other party, together with any interest refunded on such amount.

#### **4. TRANSPORTATION, TITLE, RISK OF LOSS**

4.1 MN Airlines shall be responsible for the cost of one way transportation for all Components, to Delta's Technical Operations Center, located at 1775 Aviation Boulevard, or such other Delta facility as directed by Delta, including, as applicable, all import/export licenses and fees. Costs for shipment of serviceable Components including international shipping costs and associated charges, such as customs and brokers' fees, from Delta's Technical Operations Center or other such Delta facility to MN Airlines home base at MSP will be borne by

Delta Air Lines. MN Airlines shall be responsible for all shipments of Components within and between MN Airlines cities or stations. The risk of loss for all Components during shipment will be borne by the shipping party.

4.2 Title to such Components shall vest in MN Airlines upon delivery by Delta to MN Airlines. Title to Components removed from a MN Airlines Aircraft shall vest in Delta upon delivery to Delta.

**5. LIABILITY, INDEMNITY AND INSURANCE**

5.1 To the fullest extent permitted by law, MN Airlines shall release, indemnify, defend and hold harmless Delta, and its directors, officers, employees and agents (collectively, the "Indemnified Parties" and individually, an "Indemnified Party") from and against any and all claims, damages, losses, liabilities, judgments, fines, civil penalties, suits and causes of action of every kind, character and nature whether groundless or otherwise, as well as costs and expenses of any kind, character or nature whatsoever, including but not limited to interest, court costs and attorney's fees (collectively, "Claims" and individually, a "Claim"), which in any way arise out of or result from the performance or nonperformance of Services under this Agreement or otherwise arise out of or relate to the subject matter of this Agreement, including but not limited to Claims for injury to or death of any person and loss of, damage to or destruction of any property, real or personal ; provided, however, that nothing in this section 5.1 shall be construed to limit or otherwise affect in any manner any claims by MN Airlines which (i) are the subject of any warranty or guaranty by Delta, including without limitation the Warranty provided in section 7 below or (ii) arise from or relate to a breach of contract by Delta except to the extent such breach relates to or arises from the failure by MN Airlines to perform its obligations hereunder. The foregoing release and indemnity shall apply regardless of whether or not the Claim arises out of or relates to the negligence (whether active, passive or otherwise) or was caused in part by an Indemnified Party. However, nothing contained in this Section 5 shall be construed as an indemnity in favor of an Indemnified Party from or against any Claim to the extent arising from the gross negligence or willful misconduct of such Indemnified Party. In no event shall any Indemnified Party be liable for any indirect, special or consequential damages, including lost revenues or profits and loss of use of equipment, aircraft or facilities arising out of or in connection with the performance or nonperformance of Services under this Agreement and MN Airlines' obligation to indemnify shall extend to such liabilities regardless of the party asserting such liabilities. This Agreement shall not be construed to negate, abridge or otherwise reduce any other right or obligation of indemnity which would otherwise exist as to any party or person described in this section. MN Airlines' obligations under this Section 5 shall not be limited in any way by any limitation on the amount or type of damages, compensation or benefits paid or payable by MN Airlines under Worker's Compensation Acts, disability benefit acts or other employee benefit laws or regulations. The indemnification obligations of this Section 5 shall survive termination or expiration of this Agreement.

5.2 Delta will promptly notify MN Airlines of any Claim made or suit brought within the scope of Section 5.1 and MN Airlines shall have the right to assume and conduct the defense or to effect any settlement which it may deem proper provided that it reaffirms that its indemnity obligations hereunder will cover such Claim or suit.



5.3 For the term of this Agreement, and for a period of two (2) years thereafter, MN Airlines shall carry and maintain at its own cost and expense: (i) Aviation Liability Insurance in an amount not less than Five Hundred Million Dollars (USD \$500,000,000) Combined Single Limit on an occurrence basis for Bodily Injury and Property Damage, including, without limitation, products liability, ferry flights and contractual liability and in such form as required by Delta; and (ii) Aircraft All Risk Hull Insurance, including ground taxi, in-flight, spare parts (whether on or off the Aircraft) and war risk coverage, and which contains a provision waiving any and all rights of subrogation that MN Airlines's insurers may have or acquire against Delta arising out of Services provided hereunder.

5.4 MN Airlines and Delta each agree to be solely and fully responsible for payment of all Workers' Compensation benefits for its respective employees. MN Airlines shall maintain Workers' Compensation insurance to statutory limits and employers' liability insurance in an amount not less than One Million US Dollars (\$1,000,000.00) to cover its employees on Delta's premises during the performance of Services under this Agreement.

5.5 MN Airlines shall obtain the insurance required by this Agreement from a financially sound insurance company of recognized responsibility and shall furnish Delta with a certificate of insurance evidencing such coverage prior to the commencement of Services under this Agreement. All insurance policies shall be primary without contribution from any insurance carried by Delta. All insurance policies shall continue in full force and effect for at least thirty (30) days after Delta receives written notice of cancellation, termination, or material alteration. All such insurance shall name Delta as an Additional Insured with respect to MN Airlines's indemnity obligations under this Agreement and shall contain a standard cross-liability endorsement.

## **6. EXCUSABLE DELAY**

Neither party shall be liable to the other or to any other party for, nor be deemed to be in default of this Agreement because of any failure or delay in its performance due under this Agreement occasioned by any of the following causes: acts of God or the public enemy, civil war, insurrections, riots, or civil disobedience, war, fires, floods, explosions, earthquakes, terrorism, serious accidents, epidemics or quarantine restrictions, any act of government or any agency of subdivision thereof, governmental priorities, allocations, regulations or orders affecting materials, facilities or personnel, strikes, labor difficulties, causing cessations, slowdowns or interruptions of work, in the case of Delta, damage or destruction to Delta's facilities and equipment due to any cause whatsoever, or any other cause beyond such party's reasonable control.

**7. WARRANTY**

7.1 Delta warrants and represents that the Services provided herein shall be accomplished in a manner to comply with the provisions set forth in subsection 1.3 and to the extent that any such parts or materials are overhauled, rebuilt or repaired by Delta, shall be free from defects in workmanship. All parts or materials furnished by Delta under this Agreement shall have been subject to Delta's own receiving procedures and will be selected in accordance with industry standards and shall bear an appropriate airworthiness tag. Delta will replace at no charge any such parts or materials that do not conform to the foregoing description. EXCEPT AS PROVIDED HEREIN, DELTA SPECIFICALLY DISCLAIMS AND MN AIRLINES WAIVES ANY RIGHT TO ASSERT ANY CLAIM ON ACCOUNT OF MN AIRLINES ANY WARRANTY AS TO THE QUALITY OF SUCH PARTS OR MATERIALS.

7.2 Delta will accrue any Component repair warranties which it or MN Airlines may have received from the manufacturer or vendor if such warranties have not been extinguished. As a condition precedent to performing Services, MN Airlines, Delta, and The Boeing Company shall be required to execute a warranty assignment agreement or any such similar agreement deemed necessary to establish Delta as an Authorized Agent (Agent) for MN Airlines and for Delta to act directly with Boeing under MN Airlines' Customer Services General Terms Agreement (CSGTA) and requests Boeing to treat Agent as Customer with respect to the rights and powers of Customer under the CSGTA, but only as each relates to Components. MN Airlines will retain warranty rights for consumables (material and labor) that MN Airlines personnel change or repair and labor cost recovery for rotatable parts that are changed by MN Airlines personnel.

Additionally, as required, MN Airlines will use commercially reasonable efforts to assign to Delta any warranties it has received from the manufacturer, lessor, or vendor of Components if such warranties have not been extinguished. MN Airlines and Delta shall execute all reasonable documents required by the manufacturer, lessor or vendor in order to effect assignment of any Component warranties MN Airlines may have received. All assignments of Component warranty rights to Delta pursuant to this Section will expire immediately upon termination or expiration of this Agreement and payment to Delta of all amounts due hereunder, whether or not then invoiced or yet to be invoiced, and such rights will revert back to MN Airlines.

7.2 THE WARRANTIES CONTAINED IN THIS SECTION ARE GIVEN IN LIEU OF ANY AND ALL OTHER WARRANTIES, EXPRESS OR IMPLIED, INCLUDING WITHOUT LIMITATION THOSE OF MERCHANTABILITY AND FITNESS FOR INTENDED USE. MN AIRLINES HEREBY WAIVES AND RELEASES DELTA FROM ANY OTHER OBLIGATION OR LIABILITY ARISING OUT OF ANY CLAIMED DEFECT, WHETHER IN CONTRACT, TORT, OR ANY OTHER FORM OF ACTION, AND IN NO EVENT WILL DELTA BE LIABLE FOR INCIDENTAL, CONSEQUENTIAL, OR SPECIAL DAMAGES.

**8. GENERAL**

8.1 Neither party may assign this Agreement or any of its rights or obligations hereunder without the prior written consent of the other; provided, however, Delta shall have the right to subcontract the performance of any of the Services to subcontractors who provide similar services to Delta for Delta's operations.

- 8.2 This Agreement represents the entire understanding of the parties as to its subject matter and its terms may not be modified or amended other than by a writing of even or subsequent date executed for both parties by their duly authorized representatives.
- 8.3 Neither an express waiver nor a failure by either party to demand performance of any provision of this Agreement will constitute a waiver of such provision at any time in the future or a waiver of any other provision.
- 8.4 Any provision of this Agreement which may be determined by competent authority to be prohibited or unenforceable in any jurisdiction shall, as to such jurisdiction, be ineffective to the extent of such prohibition or unenforceability without invalidating the remaining provisions hereof, and any such prohibition or unenforceability in any jurisdiction shall not invalidate or render unenforceable such provision in any other jurisdiction.
- 8.5 This Agreement shall be governed by and construed in accordance with the laws of the state of Georgia, regardless of its conflicts of laws rules.
- 8.6 This Agreement shall be binding upon and inure to the benefit of the parties hereto and their respective successors and assigns. No third party is intended to benefit from, nor may any third party seek to enforce, any of the provisions of this Agreement.
- 8.7 This Agreement may be executed in one or more counterparts, each of which shall be deemed an original and all of which, taken together, shall constitute a single enforceable agreement.
- 8.8 If either party initiates an action by way of a claim or counterclaim to enforce any of its rights under this Agreement, the prevailing party shall be entitled to receive its court costs and reasonable attorneys' fees actually incurred from the losing party.
- 8.9 MN Airlines shall appoint a representative who shall be authorized to make technical decisions for MN Airlines with respect to the Services.

**9. RETURN OF COMPONENTS**

- 9.1 Upon termination or expiration of this Agreement for any reason, MN Airlines shall return to Delta all Components belonging to Delta which are then in MN Airlines's possession and title to which has not transferred to MN Airlines pursuant to Section 4.2 no later than ten (10) days of such termination.

**10. CONFIDENTIALITY**

10.1 The parties hereto each agree that the terms of this Agreement are confidential and neither party shall disclose the terms of this Agreement to any third party without the prior written consent of the other party.

10.2 All data exchanged between the parties pursuant to this Agreement shall be considered "confidential information". Each party hereto agrees to keep confidential information provided to it by the other party in confidence and not to disclose such confidential information to any third parties or to any person within the employ of the receiving party without a need to know such information, without the prior written consent of the disclosing party, such consent not to be unreasonably withheld. The parties agree to exercise the same degree of care in protecting the other parties confidential information as it uses to protect its own confidential information, but in any event, a reasonable degree of care. Each party agrees that at the earlier of termination of this Agreement or upon a request by the other party for the return of any confidential information, it shall, as soon as practical, return such confidential information, or destroy such confidential information and certify such destruction to the disclosing party.

10.3 Notwithstanding anything to the contrary in this Agreement, either party may disclose any information which it reasonably believes to be obligated to disclose under applicable law.

**11. NOTICES**

Notices required by this Agreement will be deemed sufficient when received, if given in writing by personal delivery, by certified mail, by electronic transmission, or by fax addressed to the parties as follows, except to the extent that a specific Annex specifies that notices with respect to matters covered in that Annex are to be sent as provided therein:

IF TO DELTA:

Director - Technical Sales and Services  
Delta Air Lines, Inc.  
Hartsfield Atlanta International Airport  
Atlanta, Georgia 30320  
Facsimile No.: (404) 714-3281

Copy To: Vice President - Technical Operations, Engineering & Planning

IF TO MN AIRLINES:

MN Airlines, LLC  
1300 Mendota Heights Road  
Mendota Heights, MN 55120  
Attn: Chief Financial Officer

Copy To: MN Airlines Legal Department

**12. REPRESENTATIONS AND WARRANTIES**

12.1 Nothing in this Agreement shall require Delta or MN Airlines to take any action contrary to law or any order of any government or governmental body or office having jurisdiction over Delta or MN Airlines or over the Services to be performed hereunder, or contrary to any permit or authorization granted to Delta or MN Airlines by any government or governmental body, or contrary to any arrangement pursuant to which Delta or MN Airlines operates or utilizes any of its facilities in connection herewith or to provide any Services hereunder in connection with any operation by MN Airlines not duly authorized by the appropriate government or governmental bodies having jurisdiction over MN Airlines.

12.2 MN Airlines represents and warrants to Delta that (i) the execution, delivery and performance by MN Airlines of this Agreement has been authorized by all necessary corporate action on the part of MN Airlines, do not require any stockholder approval or approval or consent of any trustee or holder of any indebtedness or obligation of MN Airlines or of any other party with whom MN Airlines has entered into a contractual agreement with respect to any inventory support services, except such as have been duly obtained and are in full force and effect and do not contravene any law, governmental rule, regulation, judgment or order binding on MN Airlines or the certificate of incorporation or by-laws of MN Airlines or contravene or result in a breach of, or constitute a default under any material indenture, mortgage, contract or other agreement to which MN Airlines is a party or by which it or any of its properties, including, without limitation, its inventory may be bound or affected, (ii) MN Airlines is not a party to nor are any of the Common Components subject to any exclusive support agreement or arrangement which would prohibit or in any way restrict the performance of the Services by Delta, (iii) this Agreement has been duly executed and delivered by the MN Airlines and constitutes the legal, valid and binding obligation of MN Airlines enforceable against MN Airlines in accordance with its terms, except as the same may be limited by bankruptcy, insolvency, reorganization, moratorium or other similar laws affecting the rights of creditors generally and by general principles of equity, and (iv) MN Airlines has all necessary right, title and authority to contract for and obtain the Services.

IN WITNESS WHEREOF, the parties have hereunto set their hands and seals through the signatures of their duly authorized representatives, as of the date first specified herein.

MN AIRLINES, LLC

DELTA AIR LINES, INC.

By: /s/ Shaun P. Nugent  
Title: Chief Financial Officer

By: \_\_\_\_\_  
Title: Senior Vice President - Technical Operations

*ANNEX A*

*TO*

*INVENTORY SUPPORT & SERVICES*

*AGREEMENT*

Table of Contents

Annex A

<b>DEFINITIONS</b>	<b>12</b>
Inventory Maintenance; Basis for Provisioning	15
Supply Response Times	15
Configuration Management	16
Reliability Monitoring & Tracking	16
Inventory Management	16
Maintenance and Repair	16
Misuse or Abuse of Components	16
No Fault Found (NFF) Components	17
Airworthiness Directives (ADs)	17
Service Bulletins (SBs)	17
SBs Costing No More Than \$1,200	18
SBs Costing More than \$1,200	18
Determining the Cost of SBs	18
Modification Compatibility	18
Undocumented Components or Repairs	19
Return of Components	19
Shipment Methods and Costs; Packing; Required Records	19
Method of Shipment and Costs	19
Proper Packaging	19
Records and Reports	20
Warranty Administration	20
Project Manager; Customer Representatives	20
<b>ANNEX A1</b>	<b>21</b>
Description of Aircraft	21
<b>ANNEX A2</b>	<b>22</b>
Charges & Payments	22
Component Access and Exchange - Flat Rate per Aircraft	22
Component Repair & Management - Cost per Flight Hour & Rate Adjustment	22
Time & Material Rates (Delta T&M)	23
Late Charges	23
Time & Material Invoices	23
<b>ANNEX A3</b>	<b>24</b>
Rate Escalation Formulas and Adjustments	24
Power-by-the-Hour Rate Escalation Formulae	24

**DEFINITIONS**

Definitions. The following terms have the meanings defined below when used in this Agreement (whether or not underscored):

“AD” (Airworthiness Directive) means an airworthiness directive issued by the FAA and applicable to any Component.

“Aircraft” means each “N registered” Boeing 737 Next Generation aircraft that is operated by MN Airlines during the Term of this Agreement and is now or hereafter specified in Annex A1.

“AOG” (Aircraft-on-Ground) means any Aircraft which is not airworthy because of the unavailability of one or more Common Components.

“Business Day” means any day other than a Saturday or Sunday or a holiday on which the banks in Georgia, New York, or Minnesota are authorized or required by law to close for business.

“Calendar Day” means any day Sunday through Saturday including all holidays.

“Common Components” means any Component that is recognized by Delta to be form, fit and function interchangeable with those like-Components on Delta B737 Next Generation aircraft and is a Delta stocked rotatable or keyrepairable item.

“Common Station” means any station in the continental United States at which both MN Airlines and Delta operate 737 Next Generation aircraft and where Delta maintains inventory to support operations of such aircraft.

“Component(s)” means, collectively, any self-contained part, combination of parts, subassemblies or units, which perform a distinctive function necessary to the operation of a system pertaining, required or expended in connection with the Aircraft with the exception of Excluded Components. Unless otherwise noted, Components will always mean only Common Components that are provided and eligible for service under the PBTH Rate.

“Day” means Calendar Day unless otherwise specified

“Delta Time & Material (T&M) Rates” means Delta Time & Material rates as specified in Annex A2.

“Dollars” and “\$” means dollars in lawful currency of the United States of America.

“Delta Facility” means Delta Technical Operations Center at Hartsfield Atlanta International Airport or any other facility where Delta routinely performs work and has the ability to receive and issue Components.



“Effective Date” means the date this Agreement is signed by both parties.

“Excluded Component(s)” means any engine, engine life limited, primary gas path or airflow part(s), auxiliary power unit, auxiliary power unit life limited, primary gas path, or airflow part(s), landing gear (everything below the landing gear attachment points that is not a line replaceable unit) or landing gear life limited parts, items classified by Delta as expendable material, flight control surfaces, thrust reversers, passenger accommodation items ( such as passenger seats, IFE equipment), wheels, tires, and brakes, insurance spares identified as leaseable spare parts in the then current Boeing Spare Parts Price Catalog, all Non-Common Components, and Components other than Unscheduled Removals are not eligible for services under this Agreement.

“Flight Hour” means, for a particular reference period, every hour (or portion of an hour) flown by an Aircraft, computed from each take-off (wheels off) of the Aircraft until the subsequent landing (wheels on), as recorded in the technical log book (or equivalent) of the applicable Aircraft, including test flights, ferry flights, training flights, and both revenue and non-revenue flights.

“Government Authority” means any nation, state, government or sovereignty (or any political subdivision of any of the foregoing), and any entity exercising executive, legislative, judicial, regulatory or administrative functions of, or pertaining to, government or any agency or instrumentality of government.

“Maintenance Program” means MN Airlines’s FAA-approved maintenance program.

“No-Go Items” means Components that are required for Aircraft dispatch in accordance with the then current MN Airlines Minimum Equipment List manual.

“Non-Common Component” means any Component other than a Common or an Excluded Component including those set forth on Annex A4.

“Parts Related Delay” means the delay of greater than four (4) hours or cancellation of a scheduled MN Airlines flight due to the unavailability of a required No-Go Component(s), that is eligible for service under this Agreement, to rectify an airplane system failure.

“PBTH (Power-by-the-Hour) Rate” means the rate defined in Annex A2.

“SB” (Service Bulletin) means a service bulletin issued by Boeing or the manufacturer of a Common Component which recommends or provides authority for repair or modification of a Common Component.

“Services” means those services which Delta is providing or is obligated to provide under this Agreement.

“Term” means the term of this Agreement as defined in main body of Agreement.

“Unscheduled Removal” means the removal of a Component from an Aircraft due to a confirmed or suspected failure of such Component.

SCOPE OF SERVICES

***Inventory Maintenance; Basis for Provisioning***

Delta will maintain an inventory of Components to support the Aircraft within the program performance measures as more fully defined in the paragraph below entitled "Performance Measures". Delta intends to provide Component support to the Aircraft which shall include maintaining a supply and inventory management and tracking function for Components, and providing Components to MN Airlines on an exchange basis, as described below. The Components used to Support Aircraft shall be integrated into Delta's existing inventory for use on both Delta aircraft and MN Airlines's Aircraft.

***Supply Response Times***

When a Component requires removal from an Aircraft and MN Airlines does not have a replacement Component available, MN Airlines will notify Delta Front Desk and, within thirty minutes of receiving any such notice, Delta will: (i) acknowledge receipt of the request; (ii) advise MN Airlines whether a replacement Component is in stock or must be obtained from another source; and (iii) either give MN Airlines complete shipping information for the replacement Component or advise MN Airlines of when such information will become available. Delta will ship a Component to MN Airlines' home base at MSP as soon as possible; but in any event, to comply with program performance measures, all Components will be shipped within twenty-four (24) hours of Delta's receipt of a request at least ninety percent (90%) of the time in the case of Airframe and Engine Components and APU Components. Such percentages will be calculated on twelve-month rolling averages. If either such rolling average falls below the program performance measures, Delta and MN Airlines will identify the reasons for the program performance shortfall. Upon such identification, Delta and MN Airlines will take prompt action to ensure that the Components are either stocked or sourced in sufficient quantities to meet the program performance measures stated in this Annex. Notwithstanding the preceding sentences, Delta will ship Components using the same degree of expediency for a MN Airlines AOG situation that Delta generally uses for a Delta AOG situation. If Delta's general AOG handling methods are not sufficient in a particular situation, then at Sun Country's request, Delta will arrange for unique shipping methods, such as the hiring of private aircraft to ship the Component, all at MN Airlines' cost and expense.

If a Common Component can not be provided to MN Airlines in accordance with the program performance measures and Sun Country has an Aircraft that is AOG for such Component, and Delta is not currently in compliance with the twelve-month rolling average for performance measures, Delta will provide a credit to MN Airlines against future services, for an amount equal to the substantiated loan charges incurred by MN Airlines for the loan of a No Go Component when such No Go Component can not be provided by Delta to MN Airlines at a Common Station and MN Airlines has an Aircraft that is unable to complete a scheduled revenue flight due to the lack of such No Go Component. Delta's obligation for such loan borrow charges shall only be for the time period such component was unavailable from Delta and only for the actual components required to satisfy the AOG requirement.

***Configuration Management***

Delta shall have configuration management responsibility for Components. MN Airlines shall cooperate with Delta to ensure that Component configuration is maintained in accordance with FAA regulatory requirements.

***Reliability Monitoring & Tracking***

Delta shall provide to MN Airlines, an Unscheduled Removal report for Components as removed from Delta's 737-NG aircraft. This report shall be provided quarterly to aid in monitoring Component reliability trends, and failures. MN Airlines shall provide to Delta, an Unscheduled Removal report for Components removed from Aircraft. This report shall be provided quarterly to aid in monitoring Component reliability trends, and failures.

Delta will utilize its existing reliability tracking program to track Components operated on Delta aircraft only. The systems to be tracked, the calculations to be made and the performance standards against which the systems are measured will be in accordance with Delta's reliability program requirements. Data required to support such a tracking program will be supplied to Delta by MN Airlines as requested by Delta. MN Airlines will co-operate with Delta to further develop acceptable data models and methods of data transmission. For Components operating on Delta aircraft, Delta will periodically review the trend analysis and implement corrective action if reliability falls below Delta's established statistical limits. Delta will not track the reliability of Components operating on MN Airlines Aircraft. MN Airlines will utilize its existing reliability tracking program to track Components operated on MN Airlines. The systems to be tracked, the calculations to be made and the performance standards against which the systems are measured will be in accordance with MN Airlines' reliability program requirements. For Components operating on MN Airlines Aircraft, MN Airlines and Delta will periodically review the trend analysis and implement corrective action if reliability falls below Delta's established statistical limits.

***Inventory Management***

Delta shall utilize its existing inventory management system to manage, order, and track Components.

***Maintenance and Repair***

Delta will maintain the Components in accordance with current manufacturer's standard practice and component maintenance manuals and Delta's continuous airworthiness maintenance program. Each Component shipped by Delta will have attached to it a Delta Air Lines approved return to service tag (e.g. 8130, Pick List, Pass Parts Tag) indicating that the Component is airworthy with respect to the work performed.

***Misuse or Abuse of Components***

Repair and replacement of Components damaged due to MN Airlines' use of such Components outside of the manufacturer's recommendations, improper operation/maintenance, consequential damage, foreign object damage, abuse, negligence or accidental damage shall be repaired by Delta at Delta T&M Rates, or if replacement is necessary, shall be replaced at the then current manufacturer's list price. Delta shall bear all costs for the replacement of all Components deemed beyond economic repair (BER) due to normal wear and tear.

**No Fault Found (NFF) Components**

For all Components returned to Delta for Service under the PBTH Rate, if Delta cannot confirm a failure of such Component after inspection or testing, or such inspection or testing shows the Component to be in serviceable condition (“NFF”), then Delta will notify and provide inspection and testing results to MN Airlines. For NFF Components, MN Airlines will pay to Delta, \$500 for testing and recertification of NFF Component(s). If testing and recertification is accomplished by a Delta vendor, MN Airlines will pay Delta’s substantiated cost plus eight percent (8%). The preceding notwithstanding, MN Airlines will not be charged a NFF fee if the removal of the Component was based on a troubleshooting recommendation by Delta that such Component be removed. For Delta tested and re-certified NFF Component(s), if such Component(s) is subsequently removed with a confirmed failure within one hundred (100) Flight Hours of installation for the same reason as identified on the prior removal, then Delta will repair such Component and, in addition, will either: (i) issue MN Airlines a credit against an unpaid Delta invoice issued for a NFF charge, or (ii) credit to MN Airlines the amount paid by MN Airlines for the NFF charge.

**Airworthiness Directives (ADs).**

Delta will, as part of the Services, review, analyze and issue engineering documentation for the incorporation of Airworthiness Directives (AD) into Components. The actual accomplishment of any AD on Components will be charged to MN Airlines at Delta Time & Material Rates. For Components, only the amount of such Components delivered with MN Airlines’ Aircraft that did not comply with the particular AD shall be charged for AD incorporation. The amount of labor charged for accomplishing any AD will be those number of man-hours specified in the AD, or if the AD fails to specify the number of man-hours, then such information will be obtained from the relevant equipment manufacturer. If the manufacturer specifies the number of man-hours, then not more than such number will be invoiced by Delta. If the manufacturer does not supply such information, Delta will estimate the labor required to accomplish the AD and notify MN Airlines. Delta will track and invoice MN Airlines for the actual labor necessary to accomplish the AD, advising of any substantive changes, if they occur, that would significantly alter the estimate. Any labor expended on Services not required to accomplish the AD will be allocated as appropriate either to the PBTH Rate or to the Delta Time & Material Rate as provided elsewhere herein. The material part of the Delta Time & Material Rate charge will be for only that material necessary to complete the AD per the information in the AD. If the AD fails to provide the list of materials necessary to accomplish the AD, such information will be obtained from the relevant equipment manufacturer. If that information is not available, Delta will estimate the material required to accomplish the AD. Delta will track and invoice for the actual material necessary to accomplish the AD. If the only reason for removing a Component from an Aircraft was to accomplish an AD, Delta will invoice for, and MN Airlines will pay to Delta, all the costs required for the Services associated with the accomplishment of the AD and other Services required by the Maintenance Program to return the Component to serviceable condition at Delta Time & Material Rates. Any other work performed during such a shop visit to enhance any performance or life of the Component will be borne by Delta. To the extent allowed by the time limits of the AD, Delta will make all reasonable efforts to accomplish ADs in conjunction with other scheduled maintenance on such Component.

**Service Bulletins (SBs)**

As deemed necessary by Delta, Delta will from time to time, as part of the Services, review, analyze and issue engineering documentation for the incorporation of SBs into Components. For

Components requiring incorporation of a SB to meet Delta modification standard, Delta will incorporate that SB at the time Delta performs other Services on such Components, in accordance with the following:

**SBs Costing No More Than \$1,200**

If Delta reasonably estimates the incorporation of an SB into a Component will cost no more than \$1,200, when calculated at Delta Time & Material Rates, then such SB will be incorporated into the Component as part of the Services provided under the PBTH Rate. Such SB may be automatically incorporated without MN Airlines permission so long as MN Airlines is provided with notice and the SB does not change the fit, form or function of the Component. In the event the SB will change the fit, form or function of the Component, then Delta shall provide MN Airlines with a written copy of Delta Engineering Order (EO) for such change.

**SBs Costing More than \$1,200**

If Delta reasonably estimates the incorporation of an SB into a Component will cost more than \$1,200, when calculated at Delta Time & Material Rates, then such SB will be incorporated at MN Airlines's expense at Delta Time & Material Rates, but only for the number of such Components delivered with MN Airlines's Aircraft that do not have the particular SB incorporated. In the event that the Component manufacturer or some other person compensates Delta for the incorporation of the SB, then MN Airlines shall not be charged to the extent such compensation reduces Delta's cost for incorporating the SB below \$1,200.

**Determining the Cost of SBs**

The determination of the time and material elements of Delta Time & Material Rates for incorporation of SBs provided for above will be calculated in accordance with this Section. The markup on materials will be based on the current list price. The labor part of the Delta Time & Material Rate charge will be only for that number of man-hours specified in the SB, or if the SB fails to specify the number of man-hours, then such information will be obtained from the relevant equipment manufacturer. If the manufacturer specifies the number of man-hours, then not more than such number will be invoiced by Delta. If the manufacturer does not supply such information, Delta will estimate the labor required to accomplish the SB and notify MN Airlines. Delta will track and invoice for the actual labor necessary to accomplish the SB, advising of any substantive changes if they occur that would significantly alter the estimate. The material part of the Delta Time & Material Rate charges will be for only that material necessary to complete the SB per the information in the respective SB. If the SB fails to provide the list of material necessary for accomplishment of the SB, such information will be obtained from the appropriate equipment manufacturer. Using the bill of material specified either in the SB or by the manufacturer, Delta will flat-rate the material for the SB at the then-current prices. If that information is not available, Delta will estimate the material required to accomplish the SB. Delta will track and invoice for the actual material necessary to accomplish the SB. Labor expended on Services not required by the accomplishment will be allocated as appropriate either to the PBTH Rate or the Delta Time & Material Rate as provided elsewhere herein. If the only reason for removing a Component from an Aircraft is to accomplish the performance of an SB, Delta will invoice for, and MN Airlines will pay to Delta, all the costs required for the Services associated with the accomplishment of the SB and other Services required to return the Component to serviceable condition at Delta Time & Material Rates.

**Modification Compatibility**

If MN Airlines chooses not to accept a Component modification that Delta is performing on Components for Delta's fleet and such decision causes such Component to become a NonCommon Component, MN Airlines agrees to amend this Agreement to remove such Component from the support obligations of this Agreement.

MN Airlines, at its' own cost and expense, will create or revise all MN Airlines documentation and equipment, including task cards, Illustrated Parts Catalogs, test equipment and Aircraft, that are affected or necessitated by all such EOs, ADs, and SBs related to Common Components.

***Undocumented Components or Repairs***

If, in performing any Services, Delta finds any undocumented Component or repair, then Delta will promptly notify MN Airlines along with providing documentation of the undocumented Component and/or repair. MN Airlines shall then substantiate such Component within three (3) Business Days of Delta's notice. If MN Airlines is unable to substantiate such Component, Delta will not accept the undocumented Component for Services or remedy the undocumented repair at Delta Time & Material Rates.

***Return of Components***

MN Airlines will return each Component removed from an Aircraft accompanied by all required data to Delta's Technical Operations Facility at 1775 Aviation Boulevard or other such facility as directed by Delta Front Desk within five (5) Days of receipt of requested serviceable Component. MN Airlines will arrange for all such shipments except in those instances when Delta or a Delta subcontractor actually removes and replaces an Component. In such instances within the United States, Delta will pack, ship and track shipment of such Component. In such instances outside the United States, MN Airlines' maintenance control center will be responsible for coordinating the return of the unserviceable Component.

***Shipment Methods and Costs; Packing; Required Records***

**Method of Shipment and Costs.**

For any Component which requires Services, MN Airlines will provide for shipment of such Component at its own cost and expense via any reasonable method that will meet the Component return time requirement.

**Proper Packaging.**

Delta will normally deliver all serviceable Components in reusable Category I containers (as defined in ATA Specification 300). MN Airlines will return each removed Component in the same or equivalent container as the one in which the replacement was shipped. If that container or its equivalent is not returned to Delta, MN Airlines will be charged for its replacement. Each Component shipped by Delta will have attached to it a tag indicating serviceability under the standards of FAR Part 121. Regardless of the method of shipment, MN Airlines shall be responsible for ensuring that Components are properly prepared, packaged, labeled and documented under applicable ATA 300 and hazardous goods regulations. In the event Delta receives a Component from MN Airlines that is not properly packaged under applicable ATA 300 and hazardous goods regulations, Delta will so notify MN Airlines in order for MN Airlines to provide a proper package for use by Delta in returning the Component to MN Airlines. In the event MN Airlines fails to provide the proper packaging, Delta may provide such packaging required under the applicable ATA 300 and hazardous good regulations and MN Airlines shall compensate Delta for such packaging at Delta Time & Material Rates.

**Records and Reports.**

In order for a Component to be accepted for Service by Delta, MN Airlines will furnish the following data with each Component offered for Services: the Aircraft's registration and serial number that the Component was removed from; the Component name, model, and serial number; the number of Flight Hours and cycles the Component accumulated on the Aircraft; the dates the Component was installed and removed, and the reason for removal. Concurrent with shipment of serviceable Components Delta will provide data on each such Component, including, as available, aggregate flight hours and cycles accumulated, serial number, the Component name, model and serial number; the total number of hours and cycles on the Component.

At end of Term or in case of early termination, MN Airlines shall provide Delta with a written list, by serial number, part number, and nomenclature, of Components eligible for Service that are installed on MN Airlines Aircraft. Upon receipt of such written list, Delta shall provide MN Airlines with all available records for such Components.

***Warranty Administration***

On behalf of MN Airlines, Delta will administer all claims against manufacturers of removed Components on which a warranty is in effect. Delta will retain any and all warranty related compensation. To achieve this purpose, MN Airlines will cause the assignment to Delta of all warranty rights related to the Components. If MN Airlines has not made reasonable efforts for such assignment before a warranted Component must be repaired, MN Airlines will be charged for such repair at T&M. All assignments of warranty rights to Delta pursuant to this Section will expire immediately upon termination or expiration of this Agreement and such rights will revert to MN Airlines.

***Project Manager; Customer Representatives***

Delta will assign an employee with experience in project management to coordinate all aspects of the Services and to be the primary liaison with MN Airlines during the term of the Agreement. MN Airlines will designate one or more representatives who at all times during the term of this Agreement will have the authority to accept or reject work performed by Delta. MN Airlines will furnish to Delta's Project Manager a list of its personnel, with contact information, who are responsible for the subjects covered by this Agreement. Delta will furnish to MN Airlines a list of its personnel, with contact information, who are responsible for the subjects covered by this Agreement.



ANNEX A1

*Description of Aircraft*

<u>Registration #</u>	<u>Model</u>	<u>Serial Number</u>	<u>Manufacturer Date</u>	<u>Engine Type</u>	<u>APU Type</u>
N801SY	B737-800	30332	02/23/01	CFM56-7B27	131-9B
N804SY	B737-800	30689	08/07/01	CFM56-7B27	131-9B
N805SY	B737-800	30032	11/07/01	CFM56-7B27	131-9B
N806SY	B737-800	28215	08/02/98	CFM56-7B26	131-9B

In the event MN Airlines adds additional aircraft to the fleet of Aircraft, Delta reserves the right to adjust the PBTH Rate in accordance with the rates listed in Annex A2, Component Repair & Management - Cost per Flight Hour & Rate Adjustment section.

ANNEX A2

Charges & Payments

**Component Access and Exchange - Flat Rate per Aircraft**

Delta will charge MN Airlines and MN Airlines will pay to Delta a flat monthly fee for Component access and exchange to include support at Common Stations. Such fee will be computed monthly by multiplying the number of aircraft covered under this Agreement times a flat fee of \$7,500.00 USD per aircraft. Such payment will be made in accordance with Section 3.2. The rate for Component access and exchange will be calculated on the last day of each month. For Aircraft introduced into or removed from MN Airlines' fleet during any particular month, the number of Aircraft considered in operation for that particular month shall be pro-rated based on the percentage of days that month such Aircraft has spent in service. Use of an Aircraft for any portion of a calendar day, local Aircraft time, constitutes use of the Aircraft for that day, for purposes of this section. The Aircraft is considered used if it is operated for any purpose, whether revenue, charter, training, promotional or non-revenue flying.

**Component Repair & Management - Cost per Flight Hour & Rate Adjustment**

MN Airlines will pay to Delta, as compensation for Services which are described herein, as being provided on a power-by-the-hour basis for each calendar month until the expiration or termination of this Agreement, an amount equal to the product of the Power-by-the-Hour (PBTH) Rate times the total number of Flight Hours for all Aircraft during such month. The CY 2003 PBTH Rate shall be as shown in the table below and such rate is subject to an annual escalation as provided in Annex A3 of this Agreement. MN Airlines will report to Delta by no later than the third business day of each month the total number of Flight Hours for all Aircraft for the preceding month. MN Airlines will allow Delta representatives to inspect its operating records with respect to the Aircraft to verify the accuracy of the Flight Hour information. The PBTH rate for each Aircraft shall be adjusted based on the age of the aircraft as follows:

Aircraft Age, months from OEM delivery	PBTH Rate
0 to 36	\$ 55
37 to 60	\$ 115
>60	\$ 150

Delta reserves the right to amend the rates specified above in the event of unusual circumstances surrounding Aircraft introduced into this Agreement after the Effective Date. In addition, should Delta and MN enter into an agreement for the provisioning of engine maintenance services on MN's cfm56-7 aircraft engines by Delta on an exclusive basis, Delta will, in good faith, re-evaluate the above rate in an effort to provide MN with a more favorable rate.

**Time & Material Rates (Delta T&M)**

MN Airlines will pay Delta for Services performed on a Delta Time & Material Rate basis at the following rates:

- \$72.00 per hour for mechanics and inspectors.\*
- \$115.00 per hour for engineers and analysts.\*
- New material at Delta's cost plus twelve (12) percent with a per item cap on the markup of \$1,250.00 and a per line item cap on the markup of \$2,500.00\*
- Used/serviceable material at 75% of manufacturer's then-current list price with no markup.
- MN Airlines-supplied parts at 5% of MN Airlines's cost up to a maximum of \$250.00 No-charge parts or kits would not be subject to this handling fee.\*
- Outside repair at Delta's invoiced cost plus 8%.
- Consumable miscellaneous shop supplies will be provided at no charge.

\* These labor and material items will be escalated in accordance with Delta Time & Material Rate Escalation Formula Section of Annex A3.

**Late Charges**

For every day beyond the fifth Day that MN Airlines retains a removed Component or fails to provide the required data for such Component, Delta will charge MN Airlines a daily fee representing a percentage of the manufacturer's current list price, computed cumulatively as follows: (i) 1.5% per day for days 5 through 10, then: (ii) 2% per day for days 11 through 20, then; (iii) 3% per day for days 21 through 30, then; (iv) 4% per day from days 31 through 45 or until return. After day 45 the component will be considered lost and MN Airlines will be invoiced for all accumulated late charges and OEM current list price or Delta's actual replacement cost, whichever is greater.

**Time & Material Invoices**

Delta will issue to MN Airlines at least monthly, or on a project basis, an invoice setting forth the Delta Time & Material Rate charges for Services not covered by the PBTH Rate. Such invoices will be addressed and sent to MN Airlines at the following address:

MN Airlines, LLC  
1300 Mendota Heights Road  
Mendota Heights, MN 55120

Attn: Accounts Payable

MN Airlines will pay such invoices in full, without setoff or withholding, within thirty (30) days from the date of issuance.

ANNEX A3

*Rate Escalation Formulas and Adjustments*

**Power-by-the-Hour Rate Escalation Formulae**

All rates contained in this agreement will be subject to an annual economic escalation effective on the first day of January of each contract year beginning in CY 2005. All such rates shall be adjusted at an annual escalation rate/price adjustment as defined by the following formulae.

Price Adjustments shall be determined 90 days prior to the start of each calendar year.

**For Power-by-the Hour and all Flat Rates**, the Price Adjustment percentage (PA) will be determined according to the following formula:

$$PA = (P) \times (L + M - 1)$$

where P = applicable Support Service Price

$$L = \text{Labor} = \frac{0.55 \times \text{Forecasted AHE372NS}^1 \text{ for the upcoming year}}{20.6790}$$

$$M = \text{Material} = \frac{0.45 \times \text{Forecasted PPI372NS for the upcoming year}}{1.4834}$$

**For T&M Labor Rates**, the Price Adjustment (PA) will be determined using only the labor index according to the following formula:

$$PA = (P) \times (L - 1)$$

where P = applicable Fixed Price Labor Rate

$$L = \text{Labor} = \frac{\text{Forecasted AHE372NS}^2 \text{ for the upcoming year}}{20.6790}$$

where, AHE372NS is the Average Hourly Earnings index established in Standard and Poor's Data Resources Incorporated; PPI372NS is the Producer Price Index established in Standard and Poor's Data Resources Incorporated; and the denominators of the equations above are the applicable index values published for 2<sup>nd</sup> quarter of the given calendar year.

If, prior to calculation, the U.S. Department of Labor changes the base year for determination of the AHE or PPI values, such re-based values will be incorporated in the Price Adjustment calculation.

If, prior to calculation, the U.S. Department of Labor or Standard and Poors substantially revises the methodology used for the determination of the values to be used to determine the index values, or for any reason has not released values needed to determine the applicable Price Adjustment, the parties will, prior to calculation, select a substitute for such values from data published by Standard and Poors DRI or other similar data reported by non-governmental United States organizations. The substitute will lead in application to the same adjustment result, insofar as possible, as would have been achieved by continuing the use of the original values as they may have fluctuated during the applicable time period.

<sup>1</sup> For purposes of the calculation, use the index forecast published in the second calendar quarter of the year of the adjustment. Thus, for an adjustment applicable to calendar year 2006, calculated 90 days prior to January 1, 2006, use the index published in 2<sup>nd</sup> quarter 2005.

<sup>2</sup> For purposes of the calculation, use the index forecast published in the second calendar quarter of the year of the adjustment. Thus, for an adjustment applicable to calendar year 2006, calculated 90 days prior to January 1, 2006, use the index published in 2<sup>nd</sup> quarter 2005.

In the event escalation provisions are made non-enforceable or otherwise rendered null and void by any agency of the United States Government, the parties agree, to the extent they may lawfully do so, to negotiate an adjustment to the prices to reflect an allowance for increases or decreases in labor compensation and material costs.

Note: Prior to applying index values to dollars or rates, all index calculations shall be carried to the nearest ten-thousand (x.xxxx) prior to the next calculation. Any rounding of a number, as required under this clause with respect to escalation, will be accomplished as follows: if the first digit of the portion to be dropped from the number to be rounded is five or greater, the preceding digit will be raised to the next higher number. Rounding will be performed at each level of calculation prior to proceeding to the next level.

**Amendment No. 5  
to  
Technical Services Agreement**

This Amendment no. 5 ("Amendment") to the Inventory Support & Services Agreement Between Delta Air Lines, Inc ("Delta") and MN Airlines, LLC, ("Sun Country") dated October 8, 2003, (the "Agreement"), shall be effective as of the 4th day of June, 2008.

WHEREAS, the parties have entered into the Agreement for the provision of certain maintenance services to Sun Country; and

WHEREAS, the parties wish to amend the Agreement to allow for changes in term that is covered by this Agreement;

NOW, THEREFORE, the parties hereto hereby agree as follows:

1. All capitalized terms used herein but not defined shall have the meaning ascribed to them in the Agreement.

**2. TERM**

2.1 Term and Termination. The Agreement shall be extended to remain in force and effect until October 8, 2015. Except as specified in the following section, any Services in progress upon the expiration or termination hereof shall be completed subject to the terms of this Agreement and any payments due there for shall be made in accordance with the terms hereof, even if such Services extend beyond the expiration or termination of this Agreement.

2.2 At any time after seven (7) years from the Effective Date [October 8, 2003], either party may terminate this Agreement for convenience and without penalty or further obligation to the other party upon not less than one hundred eighty (180) days prior written notice to the other party

**Annex A**

**Cost per Flight Hour & Rate Adjustment**

In conjunction with the extension in term, the net Hourly PBTH cost shall be reduced by 2% effective June 5, 2008.

3. Except as amended by this Amendment, all other provisions of the Agreement shall remain in full force and effect.

IN WITNESS WHEREOF, the parties have caused this Amendment to be executed by their duly authorized representatives on the date first written above.

MN Airlines, LLC.

DELTA AIR LINES, INC.

By: /s/ John S. Frederickson  
Name: John S. Frederickson  
Title: Vice President

By: /s/ Jack Turnbull  
Name: Jack Turnbull  
Title: Vice President of Technical Sales



Delta Air Lines, Inc.  
 Department 460  
 Atlanta, Georgia 30320-6001

**Amendment  
 to  
 Technical Services Agreement**

This Amendment no. 3 ("Amendment") to the Inventory Support & Services Agreement Between Delta Air Lines, Inc ("Delta") and MN Airlines, LLC, ("Sun Country") dated October 8, 2003 (the "Agreement"), shall be effective as of 15th day of July, 2007 ("Effective Date").

WHEREAS, the parties have entered into the Agreement for the provision of certain inventory and maintenance support services from Delta to Sun Country; and

WHEREAS, the parties wish to amend the Agreement to add additional aircraft to the Agreement

NOW, THEREFORE, the parties hereto hereby agree as follows:

1. All capitalized terms used herein but not defined shall have the meaning ascribed to them in the Agreement.

The entire Agreement is hereby amended to include the following aircraft tail numbers to be included and covered under the Agreement;

Registration	Model	Serial #	Mfg. Date	Engine Type
N810SY	B737-800	29635	7/2007	CFM56-7B26
N811SY	B737-800	29660	8/2007	CFM56-7B26

2. Delta and Sun Country hereby agree that N810SY and N811SY have certain parts and/or components that are not compatible with the other Aircraft in the Agreement and with the B737-800 aircraft in Delta's fleet. Delta and Sun Country each agree to work together to reach a mutually agreed upon process for managing the differences which may exist with respect to N810SY and N811SY.

3. Except as amended by this Amendment, all other provisions of the Agreement shall remain in full force and effect.

IN WITNESS WHEREOF, the parties have caused this Amendment to be executed by their duly authorized representatives on the date first written above.

MN Airlines, LLC.

DELTA AIR LINES, INC.

By: /s/ Steven Spellman  
 Name: Steven Spellman  
 Title: CFO/COO

By: /s/ Jack Turnbill  
 Name: Jack Turnbill  
 Title: Director of Technical Sales and Marketing



Letter Agreement No. 1

This Letter Agreement No. 1 is entered into by and between Delta Air Lines, Inc. ("Delta") and Sun Country [MN Airlines, LLC, a Limited Liability Company, with its principal place of business at 1300 Mendota Heights Road, Mendota Heights, MN 55120] ("SCA") on April 1, 2008.

Delta and SCA are parties to a Inventory Support & Services Agreement dated April 23, 2003 ("Agreement") under which Delta provides SCA with access to and the use of certain parts and components, on a power-by-the-hour basis, in support of SCA's fleet of B737-800 A/C aircraft. Capitalized terms used herein but not defined shall have the meaning ascribed to them in the Agreement.

SCA plans to lease two of the Aircraft, registration numbers N807SY and N808SY (the "Lease Aircraft"), to Transavia Airline Transavia Airlines C.V., a limited partnership ("Commanditaire Vennootschap") organised and validly existing under the laws of the Netherlands, situated at Westelijke Randweg 3, 1118 CR Schiphol, for a period of six (6) months and wishes for the Lease Aircraft to continue receiving the component support during the term of the leases to Transavia. Delta agrees to allow SCA to continue the Lease Aircraft under the Agreement as follows:

- SCA shall remain responsible to report the monthly hours and to pay Delta the PBH fee for the Leased Aircraft.
- SCA shall inform Delta of the need for parts for the Leased Aircraft and Delta shall only be obligated to ship parts for the Leased Aircraft to SCA in Minneapolis.
- SCA shall remain responsible for the use and return of all parts provided to SCA for the Leased Aircraft.
- Delta's obligation to provide parts for the Leased Aircraft shall not extend beyond the term of the Agreement, regardless of the lease term for the Leased Aircraft.
- SCA shall be responsible for the filing of all documents that Delta may reasonably require in order to secure Delta's interest in the parts while on the Leased Aircraft.
- SCA shall defend, indemnify and hold Delta harmless for any and all claims which may arise from the provisioning of parts for the Leased Aircraft, except that SCA shall have no obligation to indemnify Delta for any claims which may arise due to Delta's gross negligence or willful misconduct.

In addition to the foregoing, the terms of the Agreement shall remain in full force and effect and shall continue to apply to parts provided for use on the Leased Aircraft.

If the foregoing is agreeable to SCA, please have an authorized representative sign one copy and return one original copy to Delta. This Letter Agreement No. 1 shall not become effective, and Delta shall have no obligation to provide parts for the Leased Aircraft, until it is executed by SCA and an original is returned to Delta.

---

Sincerely,

[DELTA SIGNATURE]

The foregoing is agreed to and accepted by Sun Country Airlines [MN Airlines, LLC] this 10 day of April, 2008.

Sun Country Airline [MN Airlines, LLC]

By: /s/ John S. Fredericksen

Name: John S. Fredericksen

Title: Vice President



Delta Air Lines, Inc.  
Department 460  
Atlanta, Georgia 30320-6001

MN Airlines, LLC  
DBA Sun Country Airlines  
1300 Mendota Heights Road  
Mendota Heights, MN 55120  
Attn: Tony Kubit

**Amendment No. 4**  
**to**  
**Technical Services Agreement**

This Amendment no. 4 ("Amendment") to the Inventory Support & Services Agreement Between Delta Air Lines, Inc ("Delta") and MN Airlines, LLC, ("Sun Country") dated October 8, 2003, (the "Agreement"), shall be effective as of 23rd day of May, 2008 ("Effective Date").

WHEREAS, the parties have entered into the Agreement for the provision of certain maintenance services to Sun Country; and

WHEREAS, the parties wish to amend the Agreement to allow for adding aircraft that are not currently covered by this Agreement;

NOW, THEREFORE, the parties hereto hereby agree as follows:

1. All capitalized terms used herein but not defined shall have the meaning ascribed to them in the Agreement.

The entire Agreement is hereby amended to include the following aircraft tail numbers to be included and covered under the Agreement;

Registration	Model	Serial #	Mfg. Date	Engine Type
737-7Q8	B737-700	S/N 30674	June 2004	CFM56-7B26

The PBTH agreement for this aircraft will be for a period of 12 months commencing on May 23, 2008 thru May 23, 2009 or at the time Sun Country ceases operation of this aircraft. The parts support will be on a limited basis as agreed to by both parties and established by a mutually agreed to parts list and a PBTH rate of \$98.20 per flight hour. The parts access fee will be the same as all other aircraft in the program: \$7500.00 per aircraft.

2. Except as amended by this Amendment, all other provisions of the Agreement shall remain in full force and effect.

IN WITNESS WHEREOF, the parties have caused this Amendment No. 4 to be executed by their duly authorized representatives on the date first written above.

MN Airlines, LLC.

DELTA AIR LINES INC.

By: /s/ John Fredericksen  
Name: John Fredericksen  
Title: VP & General Counsel

By: /s/ Jack Turnbull  
Name: Jack Turnbull  
Title: Vice President of Technical Sales



---

*INVENTORY SUPPORT & SERVICES*

*AGREEMENT*

*Between*

*SUN COUNTRY AIRLINES, INC.*

*And*



*DELTA AIRLINES, INC.*

This Inventory Support and Services Agreement (“Agreement”) dated as of February 01, 2001 by and between Delta Air Lines, Inc., a Delaware corporation with its principal office at Hartsfield Atlanta International Airport, Atlanta, Georgia (Delta) and Sun Country Airlines, Inc. a corporation organized under the laws of Minnesota with its principal office at 2520 Pilot Knob Road, Suite 100, Mendota Heights, Minnesota 55120 (“Sun Country”).

WITNESSETH

WHEREAS, Sun Country operates certain Boeing 737-NG aircraft powered by CFM 56-7 engines (the “Aircraft”) as further described in the Annex hereto; and

WHEREAS, Sun Country desires for Delta to provide certain aircraft inventory support services for the Aircraft as further defined in Annex A to this Agreement (the “Services”); and

WHEREAS, Delta agrees to perform such Services in accordance with the terms and conditions of this Agreement, including all agreements and Annexes incorporated herein by reference.

NOW, THEREFORE, in consideration of the mutual covenants contained herein, the parties hereby agree as follows:

**1. DESCRIPTION OF THE SERVICES**

1.1 Subject to the terms and conditions set forth in this Agreement, Delta agrees to provide to Sun Country, in accordance with the performance criteria set forth in Annex A hereto inventory support and component maintenance for Components (the “Components”) for Sun Country’s Aircraft type as more specifically identified in the Annexes hereto. Delta shall be the-exclusive provider of such Services during the term of this Agreement with the exceptions noted in the Supply Response Times section of Annex A.

1.2 Sun Country will provide to Delta, or provide Delta access to, as appropriate and as required, any and all manufacturer-issued manuals, drawings, test equipment, software upgrades and data and revisions thereto and any related logs and records and any and all other technical data not provided by Delta (hereinafter referred to as “Data”) which may be required by Delta for completion of the Services and related record keeping responsibilities at the location where any Service is to be performed prior to commencement of such Service. This includes all manuals, data, drawings and revisions thereto produced by any subcontractor, vendor and other supplier. These will be supplied to Delta in English and in a format, either paper, film or electronic usable by Delta with its present equipment. As a condition precedent to receiving any Data, Delta will be required to execute a contractor confidentiality agreement or any such similar agreement deemed necessary at the reasonable request of the manufacturer.

1.3 Standards and Practices, Regulatory Requirements- Services accomplished under this agreement will be in accordance with Delta's Continuous Airworthiness Maintenance Program as prescribed in FAA Parts 43 and 121.

## **2. TERM & TERMINATION**

2.1 This Agreement shall become effective on the date first written above (the "Effective Date") and, unless terminated earlier as provided for herein, shall remain in force and effect for seven years from the Effective Date (the Term). Except in the case of a termination for cause by either party, any Services in progress upon the termination of this Agreement or any Annex shall be completed and any payments due therefore shall be made in accordance With the terms hereof, even if the period required to complete such Services extends beyond the date of termination.

2.2 Either party may terminate this Agreement for convenience and without penalty or further obligation to the other party, no earlier than the fifth anniversary of the Agreement and upon not less than one hundred eighty (180) days prior written notice to the other party.

2.3 The above notwithstanding, either party may terminate this agreement upon not less than thirty (30) days (ten (10) in the case of non-payment) prior written notice to the other party if such other party fails to comply with any material provisions of this Agreement and such failure is not corrected, or where such failure cannot be corrected in such period, is not diligently seeking to correct such failure, within such thirty (30) day (ten (10) in the case of non-payment) period.

## **3. CHARGES AND PAYMENT**

3.1 In consideration of the Services to be provided hereunder, Delta will charge Sun Country and Sun Country agrees to pay to Delta those charges appearing in the Annex A hereto. All amounts shown and all payments due under this Agreement are in United States Dollars. All amounts will be invoiced to Sun Country and settled through direct billing unless otherwise mutually agreed to, in writing, between the Parties. All charges shown in Annexes hereto shall be subject to escalation in accordance with the escalation formula listed in Annex A3 to this Agreement.

3.2 Sun Country will pay all invoices within thirty (30) calendar days from the date of such invoice. Sun Country shall make all payments to Delta by wire transfer (Sun Country to bear the expense of the wire charges) to Citibank, N. A., New York, New York, ABA number 021000089, account number 40002617. Should an amount due to Delta by Sun Country not be paid by its due date, Sun Country will pay a late charge equal to the lesser of 1.5% per month or the maximum rate permitted by applicable law on any unpaid balance after the due date ("Past Due Rate").



3.3 Any and all taxes (excluding any tax upon the income or gross receipts of Delta), fees, duties or other charges imposed or which may be imposed by any federal, state, county or local taxing or other authority on the provision or sale of services, parts, materials and/or articles to Sun Country supplied under this Agreement (Taxes) for which Delta may be held responsible for the collection or payment on its own behalf or on behalf of Sun Country will be Sun Country's sole and exclusive responsibility and will be payable exclusively by Sun Country, provided that such taxes are in connection with the Services.

All amounts charged hereunder are exclusive of such Taxes and charges. Delta's failure to invoice or collect such taxes and charges from Sun Country will not be deemed a waiver or release of Sun Country's obligation hereunder, if any. Sun Country further agrees to indemnify and hold Delta harmless from and against the payment of any and all Taxes. In addition Sun Country agrees to repay the interest and penalties that may accrue or are otherwise incurred in connection with the Services if Sun Country is the negligent party. If a claim is made against any party for Taxes with respect to which the other party is liable for a payment or indemnity hereunder, the party receiving such claim will promptly give the other notice in writing within fifteen (15) days of receipt of such claim; provided, however, that failure to give notice will not relieve any party of its obligations hereunder. Sun Country will be required to remit payment to Delta or the tax authority, as appropriate, unless Sun Country is permitted by applicable law to contest such claim and defer payment in accordance with the law. Such contest will be coordinated by Delta and the reasonable expenses will be borne by Sun Country, and includes, but is not limited to such costs, expenses, legal and accounting fees, penalties and interest. If either party receives any refund on account of any suit or action for a Tax for which the other party has provided funds hereunder, such party shall promptly, but in any event within thirty (30) days of receipt of such refund, remit such refund to the other party, together with any interest refunded on such amount.

#### **4. TRANSPORTATION, TITLE, RISK OF LOSS**

4.1 Sun Country shall be responsible for the cost of one way transportation for all Components to Delta's Technical Operations Center in Atlanta, Georgia, or such other Delta facility as directed by Delta, including, as applicable, all import/export licenses and fees. The risk of loss for all Components during shipment shall be borne by Sun Country. Costs for shipment of serviceable Components from Delta Facilities to Sun Country facilities within the United States will be borne by Delta, however, international shipping costs and associated charges, such as customs and brokers' fees, will be borne by Sun Country if such serviceable Component is shipped to a Sun Country international station. Additionally, Sun Country shall be responsible for all shipments of Components within and between Sun Country stations. The risk of loss for all Components during shipment will pass from the shipping party to the receiving party upon delivery to a common carrier for shipment.

4.2 Title to Components shipped to Sun Country shall vest in Sun Country and title to removed Components will vest in Delta, each upon the installation of the replacement Component on an Aircraft.

## 5. LIABILITY, INDEMNITY AND INSURANCE

5.1 To the fullest extent permitted by law, Sun Country shall indemnify, defend and hold harmless Delta, its directors, officers, employees and agents from and against any and all claims, damages, losses, liabilities, judgments, costs, fines and expenses of any kind or nature whatsoever, including but not limited to interest, court costs and attorney's fees, which in any way arise out of or result from the performance or nonperformance of Services under this Agreement, including but not limited to injury to or death of any person (except for injury to or death of an employee of Delta) and damage to or destruction of any property, real or personal. However, nothing contained in this section shall be construed as an indemnity by Sun Country against any loss, liability or claim to the extent arising from the negligence or willful misconduct of Delta. In no event shall Delta be liable for any indirect, special or consequential damages, including lost revenues or profits and loss of use of equipment, aircraft or facilities arising out of or in connection with the performance or nonperformance of Services under this Agreement. The indemnification obligations of this section shall survive termination or expiration of this Agreement.

5.2 Delta will promptly notify Sun Country of any claim made or suit brought within the scope of Section 5.1 and Sun Country shall have the right to assume and conduct the defense or to effect any settlement which it may deem proper.

5.3 For the term of this Agreement, and for a period of two (2) years thereafter, Sun Country shall carry and maintain at its own cost and expense: (i) Aviation Liability Insurance in an amount not less than Five Hundred Million Dollars (USD \$500,000,000) Combined Single Limit on an occurrence basis for Bodily Injury and Property Damage, including, without limitation, products liability, ferry flights and contractual liability and in such form as required by Delta; and (ii) Aircraft All Risk Hull Insurance, including ground taxi, in-flight, spare parts (whether on or off the Aircraft) and war risk coverage, and which contains a provision waiving any and all rights of subrogation that Sun Country's insurers may have or acquire against Delta arising out of Services provided hereunder. Such liability insurance shall name Delta as an Additional Insured with respect to Sun Country's indemnity obligations under this Agreement and shall contain a standard cross-liability endorsement and a breach of warranty provision in favor of Delta.

5.4 Sun Country and Delta each agree to be solely and fully responsible for payment of all Workers' Compensation benefits for its respective employees.

5.5 Sun Country shall obtain the insurance required by this Agreement from a financially sound insurance company of recognized responsibility and shall furnish Delta with a certificate of insurance evidencing such coverage prior to the commencement of Services under this Agreement. All insurance policies shall be primary without contribution from any insurance carried by Delta. All insurance policies shall continue in full force and effect for at least thirty (30) days after Delta receives written notice of cancellation, termination or material alteration.

5.6 For the term of this Agreement, and for a period of two (2) years thereafter, Delta shall carry and maintain at its' own cost and expense: Commercial Aviation Liability Insurance in an amount not less than Five Hundred Million Dollars (USD \$500,000,000) Combined Single Limit Insurance per occurrence. Commercial General Liability insurance shall include endorsements: for personal injury; contractual liability and completed operations/product liability naming Sun Country as an additional insured; providing severability of interest, cross liability,; and which contains a provision waiving any and all rights of subrogation that Delta's insurers may have or acquire against Sun Country arising out of Services provided hereunder. Policy shall provide a breach of warranty provision in favor of Sun Country.

5.7 Delta shall obtain the insurance required by this Agreement from a financially sound insurance company of recognized responsibility and shall furnish Sun Country with a certificate of insurance evidencing such coverage prior to the commencement of Services under this Agreement. All insurance policies shall continue in full force and effect for at least thirty (30) days after Sun Country receives written notice of cancellation, termination, or material alteration.

5.8 In no event shall either party hereto be liable to the other party for incidental consequential or special damages. .

## **6. EXCUSABLE DELAY**

Neither party shall be liable to the other or to any other party for, nor be deemed to be in default of this Agreement because of any failure or delay in its performance due under this Agreement for any cause beyond its reasonable control including, but not limited to fires, floods, riots, insurrection, war, labor disputes, act of God.

## **7. WARRANTY**

7.1 Delta warrants and represents that the Services provide herein shall be accomplished in a manner to comply with the provisions set forth in subsection 1.3 and to the extent that any such parts or materials are overhauled, rebuilt or repaired by Delta, shall be free from defects in workmanship. All parts or materials furnished by Delta under this Agreement shall have been subject to Delta's own receiving procedures and will be selected in accordance with industry standards and shall bear an appropriate airworthiness tag. Delta will replace at no charge any such parts or materials that do not conform to the foregoing description. EXCEPT AS PROVIDED HEREIN, DELTA SPECIFICALLY DISCLAIMS ANY WARRANTY AS TO THE QUALITY OF SUCH PARTS OR MATERIALS. Delta will accrue any warranties which it or Sun Country may have received from the manufacturer or vendor if such warranties have not been extinguished. Sun Country will use commercially reasonable efforts to assign any warranties it has received from the manufacturer, lessor, or vendor if such warranties have not been extinguished. Delta shall execute all reasonable documents required by the manufacturer, lessor or vendor in order to effect assignment of any warranties Sun Country may have received. All assignments of warranty rights to Delta pursuant to this Section will expire immediately upon termination or expiration of this Agreement and such rights will revert back to Sun Country.

7.2 THE WARRANTIES CONTAINED IN THIS SECTION ARE GIVEN IN LIEU OF ANY AND ALL OTHER WARRANTIES, EXPRESS OR IMPLIED, INCLUDING WITHOUT LIMITATION THOSE OF MERCHANTABILITY AND FITNESS FOR INTENDED USE. SUN COUNTRY HEREBY WAIVES AND RELEASES DELTA FROM ANY OTHER OBLIGATION OR LIABILITY ARISING OUT OF ANY CLAIMED DEFECT, WHETHER IN CONTRACT, TORT, OR ANY OTHER FORM OF ACTION, AND IN NO EVENT WILL DELTA BE LIABLE FOR INCIDENTAL, CONSEQUENTIAL OR SPECIAL DAMAGES.

## **8. GENERAL**

- 8.1 Neither party may assign this Agreement or any of its rights or obligations hereunder without the prior written consent of the other.
- 8.2 This Agreement represents the entire understanding of the parties as to its subject matter and its terms may not be modified or amended other than by a writing of even or subsequent date executed for both parties by their duly authorized representatives.
- 8.3 Neither an express waiver nor a failure by either party to demand performance of any provision of this Agreement will constitute a waiver of such provision at any time in the future or a waiver of any other provision.
- 8.4 Any provision of this Agreement which may be determined by competent authority to be prohibited or unenforceable in any jurisdiction shall, as to such jurisdiction, be ineffective to the extent of such prohibition or unenforceability without invalidating the remaining provisions hereof, and any such prohibition or unenforceability in any jurisdiction shall not invalidate or render unenforceable such provision in any other jurisdiction.
- 8.5 This Agreement shall be governed by and construed in accordance with the laws of the state of Georgia , regardless of its conflicts of laws rules.
- 8.6 This Agreement shall be binding upon and inure to the benefit of the parties hereto and their respective successors and assigns. No third party is intended to benefit from, nor may any third party seek to enforce, any of the provisions of this Agreement.
- 8.7 This Agreement may be executed in one or more counterparts, each of which shall be deemed an original and all of which, taken together, shall constitute a single enforceable agreement.
- 8.8 If either party initiates an action by way of a claim or counterclaim to enforce any of its rights under this Agreement, the prevailing party shall be entitled to receive its court costs and reasonable attorneys fees from the losing party.

---

8.9 Sun Country shall appoint a representative who shall be authorized to make technical decisions for Sun Country with respect to the Services. Delta shall provide such representative with appropriate office accommodations, which may or may not be for such representative's exclusive use.

## **9. RETURN AND PURCHASE OF COMPONENTS**

9.1 Upon termination of this Agreement for any reason, Sun Country shall return all Components belonging to Delta which are then in Sun Country's possession to Delta no later than ten (10) days of such termination.

9.2 Upon termination of this Agreement for any reason other than a breach of this Agreement by Sun Country, Sun Country may request to purchase certain Common Components in accordance with the following schedule; months since Effective Date, 0 to 12, 100% of current manufacturer's list price plus twelve (12) percent administration fee; months since Effective Date, 13 to 24, 100% of current manufacturer's list price plus five (5) percent administration fee; months since Effective Date, 25 to 36, 85% of current manufacturer's list price plus five (5)% administration fee; months since Effective Date, 37 to 48, 85% of current manufacturer's list price; months since Effective Date, 49 to 60, 75% of current manufacturer's list price. Such request for purchase shall list the Component nomenclature, part number, serial number, and the quantities desired. Within thirty (30) days of such request, Delta shall advise Sun Country whether Delta will sell any of such Components and in what quantities. The purchase of Components shall be covered by a separate agreement between the parties.

Sun Country shall have the obligation to purchase Non-common Components at the end of the Term or in the case of early termination in accordance with the Common Component purchase schedule.

In order to facilitate records transfer, for all Sun Country purchased Components, Sun Country will provide to Delta the serial number, part number, and nomenclature of each purchased Component. Upon receipt of this information from Sun Country and after payment has been made to Delta, Delta shall convey title and all records related to such Components to Sun Country.

## **10. CONFIDENTIALITY**

10.1 The parties hereto each agree that the terms of this Agreement is confidential and neither party shall disclose the terms of this Agreement to any third party without the prior written consent of the other party.

10.2 All data exchanged between the parties pursuant to this Agreement and marked as confidential or proprietary (in the case of data exchanged orally and expressly stated as confidential which is followed up in writing within ten (10) days of such disclosure) shall be considered Confidential Information. Each party hereto agrees to keep Confidential information provided to it by the other party in confidence and not to disclose such Confidential Information to any third parties or to any person within the employ of the receiving party without a need to know such information, without the prior written consent of the disclosing party, such consent not to be unreasonably withheld. The parties agree to exercise the same degree of care in protecting the other parties confidential information as it uses to protect its own Confidential information, but in any event, a reasonable degree of care. Each party agrees that at the earlier of termination of this Agreement or upon a request by the other party for the return of any Confidential Information, it shall, as soon as practical, return such Confidential Information, or destroy such Confidential Information and certify such destruction to the disclosing party.

## 11. NOTICES

Notices required by this Agreement will be deemed sufficient when received, if given in writing by personal delivery, by certified mail, or by electronic transmission or by fax addressed to the parties as follows, except to the extent that a specific Annex specifies that notices with respect to matters covered in that Annex are to be sent as provided therein:

### IF TO DELTA:

Director - Technical Sales and Services  
Delta Air Lines, Inc.  
Hartsfield Atlanta International Airport  
Atlanta, Georgia 30320  
Facsimile No.: (404) 714-3281

Copy To: Vice President - Technical Operations

### IF TO SUN COUNTRY:

Sun Country Airlines, Inc.  
Director Materials  
7701 26th Avenue South  
Minneapolis, Minnesota 55450  
Tel: 651-681-3900  
Fax: 612-726-5615

### with a copy to:

Sun Country Airlines, Inc.  
2520 Pilot Knob Road, Suite 250  
Mendota Heights, Minnesota 55120  
Attn.: Luke A. Gomez, Esq.  
Legal Officer  
Facsimile no.: 651-681-0074

IN WITNESS WHEREOF, the parties have hereunto set their hands and seals through the signatures of their duly authorized representatives, as of the date first specified herein.

SUN COUNTRY AIRLINES, INC.

DELTA AIR LINES, INC.

By: /s/ Greg Mays  
Title: President and Chief Operating Officer

By: /s/ Don Mitacek  
Title: Senior Vice President - Technical Operations

**RETURN CONTRACT TO  
TECHNICAL SALES AND SUPPORT  
DEPARTMENT 460**

TECH SALES  
LEGAL  
RISK MGMT  
COMPONENT MGMT  
ENGINEERING  
CORP. TAXES  
RELIABILITY  
MATERIAL  
MANAGEMENT



---

*ANNEX A*

*TO*

*INVENTORY SUPPORT & SERVICES*

*AGREEMENT*

12

## Table of Contents

### Annex A

<b>DEFINITIONS</b>	<b>14</b>
<b>SCOPE OF SERVICES</b>	<b>16</b>
Inventory Maintenance; Basis for Provisioning	16
Configuration Management	16
Reliability Monitoring & Tracking	16
Performance Measures	17
Adjustments to Allocated Inventory	17
Inventory Management	17
Maintenance and Repair	17
Misuse or Abuse of Components	17
No Fault Found (NFF) Components	17
Airworthiness Directives (ADs)	18
Service Bulletins (SBs)	18
SBs Costing No More Than \$1,200	18
SBs Costing More than \$1,200	19
Determining the Cost of SBs	19
Undocumented Components or Repairs	20
Supply Response Times	20
Return of Components	20
Shipment Methods and Costs; Packing; Required Records	21
Method of Shipment and Costs	21
Proper Packaging	21
Records and Reports	21
Warranty Administration	21
Project Manager; Customer Representatives	21
<b>ANNEX A1</b>	
Description of Aircraft	
<b>ANNEX A2</b>	<b>23</b>
Charges & Payments	23
Allocated Inventory - Flat Rate	23
Component Repair & Management - Cost per Flight Hour & Rate Adjustment	25
Time & Material Rates (Delta T&M)	26
Late Charges	26
Time & Material Invoices	27
<b>ANNEX A3</b>	<b>28</b>
Rate Escalation Formulas and Adjustments	28
Power-by-the-Hour Rate Escalation Formulae	28
Delta Time & Material Rate Escalation Formula	28
<b>ANNEX A4</b>	<b>29</b>
Common Components	29
<b>ANNEX A5</b>	<b>30</b>
Non-Common Components	30

## DEFINITIONS

Definitions. The following terms have the meanings defined below when used in this Agreement (whether or not underscored):

“AD” (Airworthiness Directive) means an airworthiness directive issued by the FAA and applicable to any Component.

“Aircraft” means each Boeing 737 Next Generation aircraft that is operated by Sun Country Airline during the Term of this Agreement.

“Allocated Inventory” means the Common and Non-Common Components that have been assigned to support Aircraft.

“Anniversary Date” means the date one year from the date of first Aircraft revenue service (the “First Anniversary Date”) and each anniversary of such date.

“AOG” (Aircraft-on-Ground) means any Aircraft which is not airworthy because of the unavailability of one or more Components.

“Boeing” means The Boeing Company or any successor or assignee corporation which is approved by the FAA to provide maintenance, parts, and product support for the Aircraft.

“Boeing Manuals” means the various Boeing manuals that pertain or relate to the Aircraft or the Components (as they may be amended, supplemented, or superseded from time to time).

“Business Day” means any day other than a Saturday or Sunday or a holiday on which the banks in Georgia, New York, or Minnesota are authorized or required by law to close for business.

“COMAT” means company material shipped on either a Sun Country flight or Delta flight, including an affiliate of Delta.

“Common Components” means any Component that is form, fit and function interchangeable with those like-components on Delta B737NG aircraft.

“Common Station” means any United States domestic station into which both Sun Country and Delta fly B737NG aircraft and Delta maintains inventory to support such operations.

“Component(s)” means, collectively, any self-contained part, combination of parts, subassemblies or units, which perform a distinctive function necessary to the operation of a system pertaining, required or expended in connection with the Aircraft, with the exception of, engines, APU, landing gear (everything below the landing gear attachment points that is not a line replaceable unit), flight control surfaces, thrust reversers, life limited parts, passenger accommodation items (seats), unscheduled removal(s),

wheels, tires, and brakes and insurance spares identified as leaseable spare parts in the then current Boeing Spare Parts Price Catalog. Unless otherwise noted, Components will always mean both Common and Non-Common Components that are provided and eligible for service under the PBTH rate.

“Delta Facility” means Delta Technical Operations Center at Hartsfield Atlanta International Airport or any other facility where Delta routinely performs work.

“Delta Manuals” means the various Delta manuals that pertain or relate to the Aircraft or the Components (as they may be amended, supplemented, or superseded from time to time).

“Delta Time & Material Rates” means Delta Time & Material rates as specified in Annex A2.

“Dollars” and “\$” means dollars in lawful currency of the United States of America.

“Effective Date” means the date this Agreement is signed by both parties.

“FAA” means the Federal Aviation Administration of the United States of America and any U.S. Government Authority which may, after the Effective Date, have regulatory authority over the use, maintenance, or operation of the Components, concurrently with, or in replacement of, the Federal Aviation Administration.

“FAA Regulations” means all present and future laws, rules, and regulations promulgated by the FAA and all orders issued by the FAA pertaining to or affecting the Components.

“Flight Hour” means, for a particular reference period, every hour (or portion of an hour) flown by an Aircraft, computed from each take-off (wheels off) of the Aircraft until the subsequent landing (wheels on), as recorded in the technical log book (or equivalent) of the applicable Aircraft.

“Government Authority” means any nation, state, government or sovereignty (or any political subdivision of any of the foregoing), and any entity exercising executive, legislative, judicial, regulatory or administrative functions of, or pertaining to, government or any agency or instrumentality of government.

“Maintenance Program” means Sun Country’s FAA-approved maintenance program.

“Non-Common Component” means any Component other than a Common or an excluded Component.

“Non-Common Station” means any station or city in which Sun Country operates B737NG aircraft and Delta does not operate B737NG’s or have inventory to support such operations.

“OEM Manual” means the respective manuals of each original equipment manufacturer as applicable to their respective Components (as the manuals may be amended, supplemented, or superseded from time to time).

## SCOPE OF SERVICES

### ***Inventory Maintenance; Basis for Provisioning***

Delta will purchase and maintain a mutually agreed upon inventory of Components, sufficient to support the operation of the fleet of Aircraft within the program performance measures. Delta shall provide system wide Component support to the Sun Country fleet which shall include maintaining a supply and inventory management and tracking function for Components, and providing Components to Sun Country on an exchange basis, as described below. The Components shall be integrated into Delta's inventory for use on both Delta aircraft and Sun Country's Aircraft. Delta will allocate certain inventory to Sun Country at stations where Delta does not operate aircraft of the same type as the Aircraft (the "Allocated Inventory") in quantities that are mutually agreed upon between the parties. Delta may utilize any of the Allocated Inventory for its own needs, however, in such event, Delta shall use commercially reasonable efforts to replace such Allocated Inventory as soon as is practical.

Delta will supply serviceable Components to Sun Country on an exchange basis; that is, title to Components shipped to Sun Country shall vest in Sun Country and title to removed Components will vest in Delta, each upon the installation of the replacement Component on an Aircraft.

### ***Configuration Management***

Delta shall have configuration management responsibility for all Common Components. Sun Country shall have configuration management responsibility for all Non-Common Components. Sun Country shall cooperate with Delta to ensure that Common Components configuration is maintained in accordance with FAA accepted practices.

### ***Reliability Monitoring & Tracking***

Delta shall provide to Sun Country, an unscheduled removal report for Common Components removed from Delta's 737-NG aircraft. This report shall be provided quarterly to aid in monitoring Common Component reliability trends, and failures, in order to determine any adjustment to the Common Component inventory. Sun Country shall provide to Delta, an unscheduled removal report for Components removed from Sun Country Aircraft. This report shall be provided quarterly to aid in monitoring Component reliability trends, and failures, in order to determine any adjustment to the Component inventory.

Delta will utilize its existing reliability tracking program to track Common Components. The systems to be tracked, the calculations to be made and the performance standards against which the systems are measured will be in accordance with FAA accepted practices. Data required to support such a tracking program will be supplied to Delta by Sun Country as requested by Delta. Sun Country will co-operate with Delta to further develop acceptable data models and methods of data transmission. For Common Components operating on Delta aircraft, Delta will periodically review the trend analysis and implement corrective action if reliability falls below Delta's established statistical limits. Delta will not track the reliability of Components operating on Sun Country Aircraft.

### ***Performance Measures***

Delta shall provide Component support to Sun Country to ensure that Sun Country Aircraft do not experience a twelve (12) month rolling average Parts Related Delay rate greater than the Parts Related Delay rate goal that Delta sets for its own 737-NG fleet. Such goals shall be provided to Sun Country as they are established and revised from time to time. Should Component support fail to meet this performance measure, Delta shall assist Sun Country in evaluating the cause of such failure and determine and implement the appropriate corrective action(s) in a timely manner so as to meet the performance measure.

### ***Adjustments to Allocated Inventory***

Delta and Sun Country, as mutually agreed, will adjust the type and quantity of Allocated Inventory from time to time as necessary to meet program performance measures.

### ***Inventory Management***

Delta shall utilize its existing inventory management system to manage, order, and track the Allocated Inventory.

### ***Maintenance and Repair***

Delta shall be responsible for an off-wing repair and overhaul for all Components. Delta will maintain the Common Components in accordance with current manufacturer's Standard Practice manuals and Component Maintenance Manuals, which contain Delta repairs, processes, and material equivalents noted on the Delta information pages. All Delta data have been classified and substantiated as FAA acceptable (minor) and/or FAA approved (major) in accordance with Delta's Continuous Airworthiness Maintenance Program. Delta will ensure all Non-Common Components will be maintained in accordance with the applicable manufacturer's Component Maintenance Manuals in accordance with FAA Title 14 of the Code of Federal Regulations (FAR) Parts 43, 145, and/or 121.

### ***Misuse or Abuse of Components***

Repair and replacement of Components damaged due to Sun Country's use of such Component outside of the manufacturer's recommendations, improper operation/maintenance, foreign object damage, abuse, negligence or accidental damage shall be repaired by Delta at Delta T&M rates, or if replacement is necessary, shall be replaced at the then current manufacturers list price. Delta shall bear all costs for the replacement of all Components deemed beyond economic repair (BER) due to normal wear and tear.

### ***No Fault Found (NFF) Components***

For all Components returned to Delta for Service under the PBTH rate, if Delta cannot confirm a failure of such Component after inspection or testing, or such inspection or testing shows the Component to be in serviceable condition ("NFF"), then Delta will notify and provide inspection and testing results to Sun Country. For NFF Components, Sun Country will pay to Delta, \$500 for testing and recertification of NFF Component(s). If testing and recertification is accomplished by a Delta vendor, Sun Country will pay Delta's substantiated cost plus eight percent (8%). The preceding notwithstanding, Sun Country will not be charged a NFF fee if the removal of the Component was based on a troubleshooting recommendation by Delta that such Component be removed. For Delta tested and re-certified NFF Component(s), if such Component(s) is subsequently removed within one hundred (100) Flight Hours of installation with a confirmed failure for the same reason as identified on the prior removal, then Delta will repair such Component and, in addition, will either: (i) issue Sun Country a credit against an unpaid Delta invoice issued for a NFF charge, or (ii) credit to Sun Country the amount paid by Sun Country for the NFF charge.

### ***Airworthiness Directives (ADs).***

Delta will, as part of the Services, review, analyze and issue engineering documentation for the incorporation of ADs into Common Components. Sun Country will review, analyze and issue engineering documentation in a format acceptable to Delta the instructions for the incorporation of ADs into Non-Common Components. The actual accomplishment of any ADs on Components will be charged to Sun Country at Delta Time & Material Rates, but only for the amount of such Components delivered with Sun Country's Aircraft that did not have the particular AD complied with. The amount of labor charged for accomplishing any AD will be those number of man-hours specified in the AD, or if the AD fails to specify the number of man-hours, then such information will be obtained from the relevant equipment manufacturer. If the manufacturer specifies the number of man-hours, then not more than such number will be invoiced by Delta. If the manufacturer does not supply such information, Delta will estimate the labor required to accomplish the AD and notify Sun Country. Delta will track and invoice Sun Country for the actual labor necessary to accomplish the AD, advising of any substantive changes, if they occur, that would significantly alter the estimate. Any labor expended on Services not required to accomplish the AD will be allocated as appropriate either to the PBTH Rate or to the Delta Time & Material Rate as provided elsewhere herein. The material part of the Delta Time & Material Rate charge will be for only that material necessary to complete the AD per the information in the AD. If the AD fails to provide the list of materials necessary to accomplish the AD, such information will be obtained from the relevant equipment manufacturer. If that information is not available, Delta will estimate the material required to accomplish the AD. Delta will track and invoice for the actual material necessary to accomplish the AD. If the only reason for removing a Component from an Aircraft was to accomplish an AD, Delta will invoice for, and Sun Country will pay to Delta, all the costs required for the Services associated with the accomplishment of the AD and other Services required by the Maintenance Program to return the Component to serviceable condition at Delta Time & Material Rates. Any other work performed during such a shop visit to enhance any performance or life of the Common Component will be borne by Delta. To the extent allowed by the time limits of the AD, Delta will make all reasonable efforts to accomplish ADs in conjunction with other scheduled maintenance on such Component.

### ***Service Bulletins (SBs)***

As deemed necessary by Delta, Delta will, as part of the Services, review, analyze and issue engineering documentation for the incorporation of SBs into Common Components. For Common Components requiring incorporation of an SB to meet Delta modification standard, Delta will incorporate that SB at the time Delta performs other Services on such Components, in accordance with the following:

#### **SBs Costing No More Than \$1,200**

If Delta reasonably estimates the incorporation of an SB into a Common Component will cost no more than \$1,200, when calculated at Delta Time & Material Rates, then such SB will be incorporated into the Component as part of the Services provided under the PBTH Rate. Such SB may be automatically incorporated without Sun Country permission so long as Sun Country is provided with notice and the SB does not change the fit, form or function of the Component. In the event the SB will change the fit, form or function of the Component, then Delta shall provide Sun Country with a written copy of Delta Engineering Order (EO) for such change.

### **SBs Costing More than \$1,200**

If Delta reasonably estimates the incorporation of an SB into a Common Component will cost more than \$1,200, when calculated at Delta Time & Material Rates, then such SB will be incorporated at Sun Country's expense at Delta Time & Material Rates, but only for the amount of such Components delivered with Sun Country's Aircraft that do not have the particular SB incorporated. In the event that the Component manufacturer or some other person compensates Delta for the incorporation of the SB, then Sun Country shall not be charged to the extent such compensation reduces Delta's cost for incorporating the SB below \$1,200.

### **Determining the Cost of SBs**

The determination of the time and material elements of Delta Time & Material Rates for incorporation of SBs provided for above will be calculated in accordance with this Section. The markup on materials will be based on the current list price. The labor part of the Delta Time & Material Rate charge will be only for that number of man-hours specified in the SB, or if the SB fails to specify the number of man-hours, then such information will be obtained from the relevant equipment manufacturer. If the manufacturer specifies the number of man-hours, then not more than such number will be invoiced by Delta. If the manufacturer does not supply such information, Delta will estimate the labor required to accomplish the SB and notify. Delta will track and invoice for the actual labor necessary to accomplish the SB, advising of any substantive changes if they occur that would significantly alter the estimate. The material part of the Delta Time & Material Rate charges will be for only that material necessary to complete the SB per the information in the respective SB. If the SB fails to provide the list of material necessary for accomplishment of the SB, such information will be obtained from the appropriate equipment manufacturer. Using the bill of material specified either in the SB or by the manufacturer, Delta will flat-rate the material for the SB at the then-current prices. If that information is not available, Delta will estimate the material required to accomplish the SB. Delta will track and invoice for the actual material necessary to accomplish the SB. Labor expended on Services not required by the accomplishment will be allocated as appropriate either to the PBTH Rate or the Delta Time & Material Rate as provided elsewhere herein. If the only reason for removing a Component from an Aircraft is to accomplish the performance of an SB. Delta will invoice for, and Sun Country will pay to Delta, all the costs required for the Services associated with the accomplishment of the SB and other Services required to return the Component to serviceable condition at Delta Time & Material Rates.

### **Modification Compatibility**

If Sun Country chooses not to accept a Component modification that Delta is performing on Components for Delta's fleet and such decision creates the need for a larger inventory of Non-Common Components, Sun Country will either; (i) purchase, or authorize Delta to purchase, such additional Non Common Components for the inventory in a quantity sufficient to support the requirements of the Sun Country fleet, as is mutually agreed between Delta and Sun Country, or (ii) agree to amend this Agreement to remove each such NonCommon Component from Delta's support obligations.

Sun Country will create or revise all Sun Country documentation and equipment, including task cards, Illustrated Parts Catalogs, test equipment and Aircraft, that are affected or necessitated by all such EOs, ADs, and SBs related to Components.



### ***Undocumented Components or Repairs***

If, in performing any Services, Delta finds any undocumented Component or repair, then Delta will promptly notify Sun Country along with providing documentation of the undocumented Component and/or repair. Sun Country shall then substantiate such Component within three (3) days of Delta's notice. If Sun Country is unable to substantiate such Component, Delta will not accept the undocumented Component for Services or remedy the undocumented repair at Delta Time & Material Rates.

### ***Supply Response Times***

When a Component requires removal from an Aircraft and Sun Country does not have a replacement Component available, Sun Country will notify Delta Front Desk and, within thirty minutes of receiving any such notice, Delta will: (i) acknowledge receipt of the request; (ii) advise Sun Country whether a replacement Component is in stock or must be obtained from another source; and (iii) either give Sun Country complete shipping information for the replacement Component or advise Sun Country of when such information will become available. Delta or its suppliers will ship a Component to the location designated by Sun Country as soon as possible; but in any event, to comply with program performance measures, all Components will be shipped within twenty-four (24) hours of Delta's receipt of a request at least ninety percent (90%) of the time in the case of Airframe and Engine Components and ninety-five percent (95%) of the time in the case of APU Components. Such percentages will be calculated on twelve-month rolling averages. If either such rolling average falls below the program performance measures, Delta and Sun Country will identify the reasons for the program performance shortfall. Upon such identification, Delta and Sun Country will take prompt action to ensure that the Components are either stocked or sourced in sufficient quantities to meet the program performance measures stated in this Annex. Notwithstanding the preceding sentences, Delta will ship Components using the same degree of expediency for a Sun Country AOG situation that Delta generally uses for a Delta AOG situation. If Delta's general AOG handling methods are not sufficient in a particular situation, then at Sun Country's request, Delta will arrange for unique shipping methods, such as the hiring of private aircraft to ship the Component, all at Sun Country's cost and expense.

If a Common Component can not be provided to Sun Country and Sun Country has an Aircraft that is AOG for such Component, Delta will provide assistance to Sun Country in locating such Component for Sun Country to lease or borrow. In such cases, Delta will be responsible for the loan or lease charge until such Component is provided to Sun Country by Delta.

### ***Return of Components***

Sun Country will return each Component removed from an Aircraft to Delta's facility within five (5) days of its removal from the Aircraft. Sun Country will arrange for all such shipments except in those instances when Delta or a Delta subcontractor actually removes and replaces an Component. In such instances within the United States, Delta will pack, ship and track shipment of such Component. In such instances outside the United States, Delta will coordinate with Sun Country's maintenance control center on the return of the Component.

## ***Shipment Methods and Costs; Packing; Required Records***

### **Method of Shipment and Costs.**

At Sun Country's option, for any Component which requires Services, Sun Country will provide for shipment at its own cost and expense via any reasonable method that will meet the Component return time requirement.

### **Proper Packaging.**

Delta will initially deliver all serviceable Components in reusable Category 1 containers (as defined in ATA Specification 300). Sun Country will return each removed Component in the same or equivalent container as the one in which the replacement was shipped. If that container or its equivalent is not returned to Delta, Sun Country will be charged for its replacement. Each Component shipped by Delta will have attached to it a tag indicating serviceability under the standards of FAR Part 121. Regardless of the method of shipment, Sun Country shall be responsible for ensuring that Components are properly prepared, packaged, labeled and documented under applicable ATA 300 and hazardous goods regulations. In the event Delta receives a Component from Sun Country that is not properly packaged under applicable ATA 300 and hazardous goods regulations, Delta will so notify Sun Country in order for Sun Country to provide a proper package for use by Delta in returning the Component to Sun Country. In the event Sun Country fails to provide the proper packaging, Delta may provide such packaging required under the applicable ATA 300 and hazardous good regulations and Sun Country shall compensate Delta for such packaging at Delta Time & Material Rates.

### **Records and Reports.**

Sun Country will furnish the following data with each Component offered for Services: the Aircraft's registration and serial number; the Component name, model, and serial number; the number of Flight Hours and cycles the Component accumulated on the Aircraft; the dates the Component was installed and removed and the reason for removal. Concurrent with shipment of serviceable Components Delta will provide data on each such Component, including, as available, aggregate flight hours and cycles accumulated. serial number; the Component name, model and serial number; the total number of hours and cycles on the Component.

At end of Term or in case of early termination, Sun Country shall provide Delta with a written list, by serial number, part number, and nomenclature, of Components eligible for Service that are installed on Sun Country Aircraft. Upon receipt of such written list, Delta shall provide Sun Country with all available records for such Components.

### ***Warranty Administration***

On behalf of Sun Country, Delta will administer claims against manufacturers of removed Components on which a warranty is in effect. Delta will retain any warranty related compensation. To achieve this purpose, Sun Country will cause the assignment to Delta of all warranty rights related to the Components. If Sun Country has not made reasonable efforts for such assignment before a warranted Component must be repaired, Sun Country will be charged for such repair at T&M. All assignments of warranty rights to Delta pursuant to this Section will expire immediately upon termination or expiration of this Agreement and such rights will revert to Sun Country.

### ***Project Manager; Customer Representatives***

Delta will assign an employee with experience in project management to coordinate all aspects of the Services and to be the primary liaison with Sun Country during the term of the Agreement. Sun Country will

designate one or more representatives who at all times during the term of this Agreement will have the authority to accept or reject work performed by Delta. Sun Country will furnish to Delta's Project Manager a list of its personnel, with contact information, who are responsible for the subjects covered by this Agreement. Delta will furnish to Sun Country a list of its personnel, with contact information, who are responsible for the subjects covered by this Agreement.

*Charges & Payments***Allocated Inventory - Flat Rate**

Sun Country shall pay to Delta a monthly rate of 1.5% times the value of the Allocated Inventory provided to Sun Country at the mutually agreed to locations. The total value of Allocated Inventory will be calculated on the last day of the month. The value of the Allocated Inventory on the last day of the month will be the basis for the payment due and such payment will be made in accordance with Section 3.2 of the Inventory Support Agreement. The Allocated Inventory value is determined by the average list price of the Component in Delta's inventory system times the total number of Components allocated. The type and quantity of Components allocated to Sun Country shall be determined to meet the program performance measures contained in this Agreement.

Example:

Component Nomenclature	Component Part Number	Location	QTY	Unit Average List Price	Allocated Value
Computer	760SUE2-2	MSP	1	\$ 25,000	\$ 25,000
Actuator	R15048	LAX	1	\$ 8,000	\$ 8,000
Amplifier	622-5342-101	MSP/LAX	2	\$ 9,500	\$ 19,000
Transceiver	822-0334-002	SEA/MSP/JFK	3	\$ 22,000	\$ 66,000
				Total Value	\$118,000

Monthly payment = \$118,000 × 1.5% = \$1,770.00

**Pool Inventory - Flat Rate**

Sun Country shall be charged a flat monthly fee for the use of Common Components at stations where Components already exist to support Delta B737NG operations. Sun Country shall pay to Delta a monthly rate of 1% times the current value of Common Station inventory per aircraft, as most recently reported by Delta to Sun Country and revised from time to time, times a ratio of the number of Common Stations to the total number of SCA 737NG stations, times the number of Aircraft in service for that month. Such payment will be made in accordance with Section 3.2 of the Inventory Support Agreement. The rate for Pool Inventory will be calculated on the last day of each month. For Aircraft introduced into or removed from Sun Country's fleet during any particular month, the contribution to payment for pool inventory for that particular Aircraft for that particular month shall be pro-rated based on the percentage of that month such Aircraft has spent in revenue service.

Example:

REQUIRED DATA:	
Total Common Component Pool Inventory per A/C	\$597,000
Station Value of Common Inventory = 40%	\$238,800
Number of Common Stations	3(a)
Number of 737NG Stations in SCA Network	9(b)
Percentage of SCA System Overlap	33.3%(a)/(b)
Number of 737NG Aircraft in Fleet	4
CALCULATION:	
Station Value of Common Inventory	\$238,800
Multiply by System Overlap Percentage	33.3%
Multiply by number of 737NG aircraft	4
Multiply by monthly rate	1%
Total Monthly Charge for Pool Inventory	\$ 3,180

As mutually agreed, Sun Country will have the right to independently obtain & review Component cost data for Allocated Inventory and Pool Inventory for the purpose of confirming the Delta determined cost valuation quantity of the Allocated Inventory and Pool Inventory as described above.

## Component Repair & Management - Cost per Flight Hour & Rate Adjustment

Sun Country shall pay to Delta \$95 per flight hour for Component repair and warranty administration.

In the event Sun Country introduces additional Aircraft into this Agreement, the PBTH rate for such Aircraft shall be based on the age of such aircraft as follows:

<u>Aircraft Age at Induction, months from OEM deliver</u>	<u>PBTH Rate</u>
0 to 6	\$ 95
7 to 12	\$ 118
13 to 28	\$ 133
29 to 36	\$ 145
>37	\$ 150

Delta reserves the right to amend the rates specified above in the event of unusual circumstances surrounding the aircraft being introduced into this Agreement. For the avoidance of doubt, the rate shown above shall only be applicable to the aircraft being introduced. All other Aircraft shall be charged at the PBTH Rate, subject to escalation.

## **Time & Material Rates (Delta T&M)**

Sun Country will pay Delta for Services performed on a Delta Time & Material Rate basis at the following rates:

- \$65.00 per hour for mechanics and inspectors.\*
- \$100.00 per hour for engineers and analysts.\*
- New Material at Delta's cost plus twelve (12) percent with a per item cap on the markup of \$1,250.00 and a per line item cap on the markup of \$2,500.00
- Used/serviceable material at 75% of manufacturer's then-current list price with no markup.
- Sun Country-supplied parts at 5% of Sun Country's cost up to a maximum of \$250.00 No-charge parts or kits would not be subject to this handling fee.
- Outside repair at Delta's invoiced cost plus 8%.
- Consumable miscellaneous shop supplies will be provided at no charge.

\* These labor items will be escalated in accordance with Delta Time & Material Rate Escalation Formula Section of Annex A3.

## **Late Charges**

For every day beyond the fifth business day that Sun Country retains a removed Component or fails to provide the required data for such Component, Delta will charge Sun Country a daily fee representing a percentage of the manufacturer's current list price, computed cumulatively as follows: (i) 1.5% per day for days 6 through 10, then; (ii) 2% per day for days 11 through 30, then; (iii) 3% per day for days 21 through 30, then; (iv) 4% per day for day's 31 until return.

---

**Time & Material Invoices**

Delta will issue to Sun Country at least monthly, or on a project basis, an invoice setting forth the Delta Time & Material Rate charges for Services not covered by the PBTH Rate. Such invoices will be addressed and sent to Sun Country at the following address:

Sun Country Airlines  
7701 26th Ave south  
Minneapolis, MN 55450

Attn: Karen Nesheim

Sun Country will pay such invoices in full, without setoff or withholding, within thirty (30) days from the date of issuance.



*Rate Escalation Formulas and Adjustments***Power-by-the-Hour Rate Escalation Formulae**

The initial PBTH Rate of \$95 per flight hour set out in Annex A2, Component Repair & Management will be subject to escalation on the first day of January of each year beginning in 2002 in accordance with the following formula:

$$NR = CY \times (PPIC/PPIP)$$

Where:

NR = the rate to apply in the new calendar year

CY = the rate from the current Contract Year as previously escalated and adjusted

PPIC = the previous year's average data for the twelve (12) months ending October from the "Producer Price Index - Commodities - Aircraft Parts and Auxiliary Equipment" as reported by the U.S. Department of Labor, Bureau of Labor Statistics

PPIP = the average data for the twelve (12) months ending October from the year before the previous year from the "Producer Price Index - Commodities - Aircraft Parts and Auxiliary Equipment" as reported by the U.S. Department of Labor, Bureau of Labor Statistics

**Delta Time & Material Rate Escalation Formula**

The initial Time and Material Rates set out in Annex A2, Time and Material Rates will be subject to escalation on the first day of January of each year beginning in 2002 in accordance with the following formula:

$$NR = CY \times (PPIC/PPIP)$$

Where:

NR = the rate to apply in the new calendar year

CY = the rate from the current Contract Year as previously escalated and adjusted

PPIC = the previous year's average data for the twelve (12) months ending October from the "Producer Price Index - Commodities - Aircraft Parts and Auxiliary Equipment" as reported by the U.S. Department of Labor, Bureau of Labor Statistics

PPIP = average data for the twelve (12) months ending October from the year before the previous year from the "Producer Price Index - Commodities - Aircraft Parts and Auxiliary Equipment" as reported by the U.S. Department of Labor, Bureau of Labor Statistics

---

**ANNEX A4**

***Common Components***

As defined in Definitions section of this Annex.

**ANNEX A5**

***Non-Common Components***

(As defined in the Definitions section and listed below, this list shall be amended from time to time)

<b>CSUFI</b>	<b>PN</b>	<b>Noun</b>	<b>SPC</b>
25640001 210J	A12SA	MEGAPHON	2
25314105 105	DLH549-017	HOT CUP	2
23222101 035	G7165-01	PANEL	2
23124101 035M	G7404-24	PANEL	2
34439101 025R	G7407-01	PANEL	2
23221102 005M	NA138-714B	DECODER	2
25600039U140J	R0202A207	RAFT	2
25311125 075	XX72067002	OVEN	2
25311105 112J	11160-1	RAIL AY	2
25311105113	11225-1	MAKER	2
38110102105J	163CV59	GAUGE	2
31119490A350J	233A3207-7	MODULE	2
31151110 070	285A1710-1	MODULE	2
23510201 070	5145-1-64	PANEL	2
23340202 005R	743-0288-002	AMUX	2
34530206 005T	822-1338-001	TRNSPNDR	2
35310004Y010	9700C1ABF23A	BOTTLE	2
23711101 005	980-6022-001	RECORDER	2
23711201 050J	980-6116-001	PANEL	2
23340104 005K	980-9900-001	PLAYER	2
33	BR9643-21	LIGHT	6
25314105113	DLH1950	CONTAINR	6
35128520 310S	MF20-003	MASK AY	6
25640020A005	P0723-103	VEST	6
25600010 006S	P0723-103C	VEST	6
25600087C180J	P0723E105P	VEST	6
25640032 195	S6-01-0005-306	AID KIT	6
33510004 035J	0105924-005	LIGHT	6
57500015 060	115A4714-1	PANEL AY	6
25314105 110	225007-3	CONTAINR	6
25311105 110	225036-3	CONTAINR	6
31119490A540	233A3211-1	MODULE	6
33119001175	415-1657	LTPLATE	6
33119001 610J	415-1718	LTPLATE	6
33119004 110	415-728	LTPLATE	6
33119004 115	415-729	LTPLATE	6
33119001 470J	415-737	LTPLATE	6
25205123 055	435W1200-1K	RACK	6
23510003 060L	63999-000	MIC	6
23510026 020U	64000-102	HEADSET	6
33510516 070	702409-1002	IND	6

---

<b>CSUFI</b>	<b>PN</b>	<b>Noun</b>	<b>SPC</b>
33510516 075	702409-1003	IND	6
33518101 060	702409-1007	IND	6
33518101 065	702409-1008	IND	6
33518101 070	702409-1009	IND	6
33510516115	81000-22602	LIGHT AY	6
33510516 235	81000-22605	LIGHT AY	6
33510516 215	81000-22607	LIGHT AY	6
33510516 120	81000-22608	LIGHT AY	6
31318101 010	971-4193-001	ACCELER	6

February 4, 2002

Raytheon Systems Company  
P.O. Box 6900CBN: 178  
Greenville, TX 75403-6900  
Attn: Royall G.G.

Re: License for use of Delta STC SA2166SO on MSN 25493

Dear Sirs:

This letter agreement sets forth the terms and conditions pursuant to which Delta Air Lines, Inc. ("Delta") will grant to Raytheon Systems Company ("Licensee") a non-exclusive, non-transferable license to use a certain Delta Supplemental Type Certificate ("STC") in the installation of a hatch kit, part number 53-0496-500, in the aircraft owned or operated by Licensee bearing manufacturer's serial number 25493 (the "Aircraft").

1. Scope of License.

Delta hereby grants to Licensee a non-exclusive, non-transferable license to use Supplemental Type Certificate number SA2166SO for the installation by Licensee or its authorized repair or modification facility of a hatch kit, part number 53-0496-500, in the Aircraft. Delta represents to Licensee that Delta owns the rights to such STC and has the right and authority to grant this license. This license may not be transferred, sold or assigned by Licensee, nor may Licensee use it for the purpose of modifying any other parts or any other aircraft for itself or any other operator; provided, however, that Licensee may assign its interest herein with a transfer of ownership or possession of the Aircraft modified pursuant to the terms of this license, and any transferee under the terms of this provision may transfer its interest herein in the same manner.

2. Price for License.

Pursuant to a Purchase Agreement dated as of even date herewith, Licensee will purchase from Delta one (1) hatch kit, part number 53-0496-500, in the amount of Ten Thousand Three Hundred Forty Seven Dollars (\$10,347), which purchase price shall include the STC licensed hereunder. Licensee agrees and acknowledges that the STC shall be used solely in connection with the Aircraft.

3. Taxes.

In addition to the amounts set forth above, Licensee will reimburse Delta (net of any additional taxes of such reimbursement) the amount of any and all taxes (except United States Income taxes) and fees of whatever nature, including customs duties and fees, paid or incurred by Delta as a result of or in connection with granting the license hereunder. If claim is made against Delta for any such tax, Delta will promptly notify Licensee. If seasonably requested by Licensee in

writing, Delta will at Licensee's expense take such action as Licensee may reasonably direct with respect to such claim, and any payment by Delta of such tax will be made under protest, if protest is necessary and proper. If payment is made, Delta will, at Licensee's expense, take such action as Licensee may reasonably direct to recover such payment and will, if requested, permit Licensee in Delta's name to file a claim or prosecute an action to recover such payment.

4. Waiver; Limitation of Liabilities.

THE OBLIGATIONS AND LIABILITIES OF DELTA HEREUNDER, AND THE RIGHTS AND REMEDIES OF LICENSEE HEREUNDER ARE EXCLUSIVE AND IN SUBSTITUTION FOR, AND LICENSEE HEREBY WAIVES, RELEASES AND RENOUNCES ALL OTHER WARRANTIES, GUARANTEES, OBLIGATIONS, LIABILITIES, RIGHTS AND REMEDIES, EXPRESS OR IMPLIED, ARISING BY LAW OR OTHERWISE, WITH RESPECT TO ANY ERROR IN DATA, THE PERFORMANCE OF SERVICES, OR ANY OTHER THING DELIVERED UNDER THIS AGREEMENT, THE VALIDITY OR SCOPE OF ANY PATENT INCLUDED IN THE DATA, ANY ACTUAL OR ALLEGED INFRINGEMENT OF ANY THIRD PARTY-OWNED PATENT BY ANY PREPARATION, TRANSFER OR USE OF DATA AND WITH RESPECT TO ANY NONCONFORMANCE OR DEFECT IN PROCESSES USED OR PRODUCTS MADE IN ACCORDANCE WITH OR COVERED BY THE DATA, INCLUDING BUT NOT LIMITED TO (A) ANY IMPLIED WARRANTY OF MERCHANTABILITY OR FITNESS, (B) ANY IMPLIED WARRANTY ARISING FROM COURSE OF PERFORMANCE, COURSE OF DEALING OR USAGE OF TRADE, (C) ANY OBLIGATION, LIABILITY, RIGHT, CLAIM OR REMEDY IN TORT, WHETHER OR NOT ARISING FROM DELTA'S NEGLIGENCE, WHETHER ACTIVE, PASSIVE OR IMPUTED, AND (D) ANY OBLIGATION, LIABILITY, RIGHT, CLAIM OR REMEDY FOR LOSS OF OR DAMAGE TO ANY PROPERTY INCLUDING, BUT NOT LIMITED TO, ANY AIRCRAFT, AND (E) ANY OBLIGATION, LIABILITY, RIGHT, CLAIM OR REMEDY FOR LOSS OF USE, REVENUE OR PROFIT, OR FOR ANY OTHER DIRECT, INCIDENTAL OR CONSEQUENTIAL DAMAGES.

5. Indemnification.

Licensee agrees to defend, indemnify and hold Delta, its assignees and their respective officers, agents and employees harmless from and against all liabilities, damages, losses, expenses, claims and judgments, including all costs and expenses incident thereto, which may be suffered by, accrued against, be charged to or recoverable from Delta, its assignees and their respective officers, agents or employees, by reason of loss of or damage to property, including any aircraft, or injury to or death of any person, whether or not occasioned by Delta's negligence, active, passive or imputed arising out of or in any way connected with the use by Licensee or any assignee or transferee of any rights granted hereunder, services provided in connection therewith, or the repair, modification, maintenance or use of any aircraft, component or part.

6. Proprietary Information; Remedies.

Licensee acknowledges and agrees that the rights to ownership of the STC and the data reflected therein are solely with Delta and are proprietary to it and will be used by Licensee or its authorized repair or modification facilities solely for the purposes described herein. Licensee agrees never to assert an ownership interest in the STC or the data reflected therein, or take any action contrary to Delta's rights therein. In the event Licensee asserts such interest or takes such action, Licensee agrees that Delta may revoke this license with respect to the Aircraft modified hereunder. Should Delta notify Licensee of such revocation, Licensee will immediately cease all aircraft operations under the STC. The parties agree that, because of the nature of the rights Delta has under this license, remedies at law may not be adequate to provide for effective enforcement of Delta's rights hereunder and, accordingly, Licensee agrees and acknowledges that Delta may seek and obtain injunctive relief to enforce its rights hereunder, and Licensee further agrees not to contest the jurisdiction of any U.S. District Court in which Delta may bring such an action.

7. Governing Law; Negotiated Agreement; Entire Agreement.

This Agreement, including all matters of construction, validity and performance, shall be governed by, and construed in accordance with, the laws of the State of Georgia, U.S.A. as applicable to contracts entered into in such state by residents thereof and to be performed wholly within such state, and without reference to conflicts of law principles. Licensee and Delta agree that this Agreement, including Articles 4, 5 and 6, has been the subject of discussion and negotiation and is fully understood by the parties, and that the royalty for the use of the license and the other terms hereof were arrived at in consideration of Articles 4, 5 and 6. This Agreement contains the entire agreement between the parties with respect to the subject matter hereof and supersedes any previous proposals, understandings, commitments or representations whatsoever, oral or written. This Agreement shall not be varied except by written agreement of the same or subsequent date signed on behalf of Licensee and Delta by their respective duly authorized representatives.

If this accurately sets forth our understanding, please sign both counterparts of this letter and return one to the attention of the undersigned on or before February 4, 2002.

Very truly yours,  
DELTA AIR LINES, INC.

By: /s/ Basil Papayoti  
Name: Basil Papayoti  
Title: Director Tech Sales and Marketing

ACCEPTED AND AGREED TO  
THIS 20 day of February, 2002.

RAYTHEON SYSTEMS COMPANY

By: /s/ Geoffrey Royall  
Name: Geoffrey Royall  
Title: Principal Subcontract Specialist



## PURCHASE AGREEMENT

This Agreement, dated as of February 4, 2002 (the "Agreement"), is by and between Delta Air Lines, Inc., a Delaware corporation with its principal place of business at Hartsfield Atlanta International Airport, Atlanta, Georgia, ("Delta") and Raytheon Systems Company, a Texas corporation with its principal place of business at Majors Field, Greenville, Texas (the "Customer").

In consideration of the mutual covenants contained herein, Delta and Customer hereby agree as follows:

### 1. THE PURCHASE ITEM

- 1.1 Description. Delta will fabricate and sell to Customer one (1) Access Hatch Kit, EE Bay, Part Number 53-0496-500, FMC Code 7A344, QA Codes 3, 11, 13, 17, 19 (the "Part").
- 1.2 STC License. Pursuant to a Letter Agreement dated as of even date herewith, Delta will also grant Customer a non-exclusive, non-transferable license to use Supplemental Type Certificate number SA2166SO (the "STC") for the installation by Customer or its authorized repair or modification facility of the Part in the aircraft bearing manufacturer's serial number 25493 (the "Aircraft").

### 3. PRICE AND PAYMENT

- 3.1 Price. The price for the Part is Ten Thousand Three Hundred Forty Seven Dollars (\$10,347). This price shall also include the use of the STC for the installation of the Part in the Aircraft.
- 3.2 Taxes. All amounts charged hereunder are exclusive of any and all taxes (excluding any tax upon the income of Delta), fees, duties or other charges which have been or may be imposed by any federal, state, county, local or foreign taxing or other authority on the use of the Equipment or the provision or sale of services, parts, materials and/or articles supplied under this Agreement ("Taxes"). All Taxes are payable exclusively by Customer regardless of whether Delta may be held responsible for the collection or payment on its own behalf or on behalf of Customer. Delta's failure to invoice or collect Taxes from Customer shall not be deemed a waiver or release of Customer's obligation hereunder, if any.

3.3 **Payment.**

3.3.1 Delta will invoice Customer for the Part within thirty (30) days of delivery of the Part to the Customer.

3.3.2 Customer will pay the invoice in immediately available funds within thirty (30) days of its date. Delta will charge Customer, and Customer will pay to Delta promptly, a late charge of 1.5% per month on any unpaid balance after the due date. Invoices will be sent to Customer at the following address:

Raytheon Systems Company  
P.O. Box 6900  
Greenville, TX 75403-6900

3.3.3 All payments will be made at Customer's expense (i) by wire transfer of immediately available United States Dollar funds to Delta's account at Citibank, N.A., 399 Park Avenue, New York, New York, Account No. 30453617, ABA Number 021000089, with the request that the bank advise Delta by telephone at (404) 714-3253 upon transfer of the funds, or (ii) as otherwise agreed to by the parties.

3.3.4 If Delta should be required to initiate an action to collect any amount owed under this Agreement, it will be entitled to recover all costs of suit and attorney's fees from Customer.

**4. DELIVERY; TITLE AND RISK OF LOSS**

4.1 **Delivery of Part.** The Part will be shipped via Federal Express Overnight service FOB Delta's place of business and shall be shipped to:

Raytheon Systems Company  
Greenville Operations  
BLDG 157, FM 1570  
Greenville, TX 75402.

The Part will be shipped collect and billed to Customer's Federal Express account no. 18692138-0.

4.2 **Delivery Date.** The delivery date shall be no later than April 8, 2002.

4.2 **Risk of Loss.** Risk of loss or damage to the Part shall be the responsibility of Customer upon shipment of the Part from Delta's facilities.

4.3 **Title.** Title to the Part shall transfer to the Customer upon shipment of the Part from Delta's facilities.

**5. EXCUSABLE DELAY**

Delta shall not be liable to Customer or any other party for, nor be deemed to be in default of this Agreement because of, any failure or delay in its performance due under this Agreement for any cause beyond Delta's reasonable control.

**6. WARRANTY DISCLAIMER AND LIMITATION OF LIABILITY**

CUSTOMER HEREBY WAIVES AND DELTA EXPRESSLY DISCLAIMS ALL WARRANTIES, GUARANTEES, AND REPRESENTATIONS OF ANY KIND, EXPRESS OR IMPLIED, ARISING BY LAW OR OTHERWISE, WITH RESPECT TO THE PART AND THE STC. DELTA EXPRESSLY DISCLAIMS ALL WARRANTIES, ALL GUARANTEES AND REPRESENTATIONS, EXPRESS OR IMPLIED, ARISING BY LAW OR OTHERWISE, INCLUDING WITHOUT LIMITATION, ANY IMPLIED WARRANTY OF MERCHANTABILITY AND FITNESS FOR A PARTICULAR PURPOSE, ANY IMPLIED WARRANTY ARISING FROM THE COURSE OF PERFORMANCE, AND COURSE OF DEALING OR USAGE OF TRADE. CUSTOMER HEREBY WAIVES AND RELEASES DELTA FROM ANY OTHER OBLIGATION OR LIABILITY ARISING OUT OF ANY CLAIMED DEFECT, WHETHER IN CONTRACT, TORT, OR ANY OTHER FORM OF ACTION, AND IN NO EVENT WILL DELTA BE LIABLE FOR INCIDENTAL, CONSEQUENTIAL OR SPECIAL DAMAGES, INCLUDING BUT NOT LIMITED TO LOSS OF PROFITS, EVEN IF DELTA SHALL HAVE BEEN ADVISED OF THE POSSIBILITY OF SUCH POTENTIAL LOSS OR DAMAGE.

**7. GENERAL**

- 7.1 Neither party may assign this Agreement or any of its rights or obligations hereunder without the prior written consent of the other.
- 7.2 The terms and conditions set forth in this Agreement and the Letter Agreement between the parties of even date herewith constitute the entire agreement and understanding between Delta and Customer as to the subject matter of this transaction and its terms may not be modified or amended other than by a writing of even or subsequent date executed for both parties by their duly authorized representatives.
- 7.3 Neither an express waiver nor a failure by either party to demand performance of any provision of this Agreement will constitute a waiver of such provision at any time in the future or a waiver of any other provision.
- 7.4 This Agreement shall be governed by and construed in accordance with the laws of the State of Georgia, regardless of its conflict of laws rules and Customer consents to the jurisdiction of the federal and state courts situated in Fulton County, Georgia, for the resolution of any dispute arising under this Agreement.

- 7.5 This Agreement shall be binding upon and inure to the benefit of the parties hereto and their respective successors and assigns. No third party is intended to benefit from, nor may any third party seek to enforce, any of the terms of this Agreement.
- 7.6 This Agreement may be executed in one or more counterparts, each of which shall be deemed an original and all of which, taken together, shall constitute a single enforceable agreement.
- 7.7 Any provision of this Agreement which may be determined by competent authority to be prohibited or unenforceable in any jurisdiction shall, as to such jurisdiction, be ineffective to the extent of such prohibition or unenforceability without invalidating the remaining provisions hereof, and any such prohibition or unenforceability in any jurisdiction shall not invalidate or render unenforceable such provision in any other jurisdiction.
- 7.8 Notices required by this Agreement will be deemed sufficient when received if given in writing by personal delivery, by commercial courier or by electronic transmission (followed by hard copy) addressed to the parties as follows:

If to Delta:

William Hicks  
Account Manager, Technical Sales & Marketing  
Delta Air Lines, Inc.  
1775 Aviation Blvd.  
Department 590  
Hartsfield Atlanta International Airport  
Atlanta, Georgia 30320  
Facsimile No.: (404) 714-3281  
Telephone No.: (404) 714-3253

If to Customer:

Raytheon Systems Company  
P.O. Box 6900CBN:178  
Greenville, TX 75403-6900  
Attn: Royall G.G.

Facsimile No.: (903) 457-7921  
Telephone No.: (903) 457-6362

IN WITNESS WHEREOF, each party has caused this Agreement to be duly executed and delivered by its duly authorized signatory as of the date set forth above.

RAYTHEON SYSTEMS COMPANY

DELTA AIR LINES, INC.

By: /s/ Geoffrey Royall  
Name: Geoffrey Royall  
Title: Principal Subcontract Specialist

By: /s/ Basil Papayoti  
Name: Basil Papayoti  
Title: Director Tech Sales and Marketing



Delta Air Lines, Inc.  
 Department 590  
 Atlanta, Georgia 30320-6001

**Amendment  
 to  
 Technical Services Agreement**

This Amendment no. 2 ("Amendment") to the Inventory Support & Services Agreement Between Delta Air Lines, Inc and MN Airlines, LLC ("MN") dated October 8, 2003 (the "Agreement"), is entered into this 18 day of March, 2005.

WHEREAS, the parties have entered into the Agreement for the provision of certain inventory and maintenance support services from Delta to MN; and

WHEREAS, the parties wish to amend the Agreement to add an additional aircraft to the Agreement.

NOW, THEREFORE, the parties hereto hereby agree as follows:

1. All capitalized terms used herein but not defined shall have the meaning ascribed to them in the Agreement.
2. The following aircraft is hereby added to the Agreement as a part of Annex A1 and shall be considered an Aircraft:

Registration	Model	serial #	mfg. Date	engine type
N808SY	B737-800	33021	03/2005	CFM56-7B27
N809SY	B737-800	30683	03/2005	CFM56-7B27

2. Delta and MN hereby agree that N808SY and N809SY have certain parts and/or components that are not compatible with the other Aircraft in the Agreement and with the B737-800 aircraft in Delta's fleet. Delta and MN each agree to work together to reach a mutually agreed upon process for managing the differences which may exist with respect to N808SY and N809SY.

3. Except as amended by this Amendment, all other provisions of the Agreement shall remain in full force and effect.

IN WITNESS WHEREOF, the parties have caused this Amendment to be executed by their duly authorized representatives on the date first written above.

MN AIRLINES, LLC

DELTA AIR LINES, INC.

By: /s/ Shaun P. Nugent  
 Name: Shaun P. Nugent  
 Title: Chief Executive Officer

By: /s/ GARY SWANSON  
 Name: GARY SWANSON  
 Title: MANAGING DIRECTOR, TECHNICAL SALES



Delta Air Lines, Inc.  
 Department 590  
 Atlanta, Georgia 30320-6001

**Amendment  
 to  
 Technical Services Agreement**

This Amendment no. 1 ("Amendment") to the Inventory Support & Services Agreement Between Delta Air Lines, Inc and MN Airlines, LLC ("MN") dated October 8, 2003 (the "Agreement"), is entered into this 8<sup>th</sup> day of November, 2004.

WHEREAS, the parties have entered into the Agreement for the provision of certain inventory and maintenance support services from Delta to MN; and

WHEREAS, the parties wish to amend the Agreement to add an additional aircraft to the Agreement.

NOW, THEREFORE, the parties hereto hereby agree as follows:

1. All capitalized terms used herein but not defined shall have the meaning ascribed to them in the Agreement.
2. The following aircraft is hereby added to the Agreement as a part of Annex A1 and shall be considered an Aircraft:

Registration	Model	serial #	mfg. Date	engine type
N807SY	B737-800	33016	10/1/2004	CFM56-7B27

2. Delta and MN hereby agree that N807SY has certain parts and/or components that are not compatible with the other Aircraft in the Agreement and with the B737-800 aircraft in Delta's fleet. Delta and MN each agree to work together to reach a mutually agreed upon process for managing the differences which may exist with respect to N807SY.

3. Except as amended by this Amendment, all other provisions of the Agreement shall remain in full force and effect.

IN WITNESS WHEREOF, the parties have caused this Amendment to be executed by their duly authorized representatives on the date first written above.

MN AIRLINES, LLC

DELTA AIR LINES, INC.

By: /s/ Shaun P. Nugent  
 Name: Shaun P. Nugent  
 Title: Chief Financial Officer

By: /s/ David Leclair  
 Name: David Leclair  
 Title: Q.M. Tech Sales



Delta Air Lines, Inc.  
Department 590  
Atlanta, Georgia 30320-6001

**Amendment  
to  
Technical Services Agreement**

This Amendment no. 2 (“Amendment”) to the Inventory Support & Services Agreement Between Delta Air Lines, Inc and MN Airlines, LLC (“MN”) dated October 8, 2003 (the “Agreement”), is entered into this 18 day of March, 2005.

WHEREAS, the parties have entered into the Agreement for the provision of certain inventory and maintenance support services from Delta to MN; and

WHEREAS, the parties wish to amend the Agreement to add an additional aircraft to the Agreement.

NOW, THEREFORE, the parties hereto hereby agree as follows:

1. All capitalized terms used herein but not defined shall have the meaning ascribed to them in the Agreement.

2. The following aircraft is hereby added to the Agreement as a part of Annex A1 and shall be considered an Aircraft:

Registration	Model	serial #	mfg. Date	engine type
N808SY	B737-800	33021	03/2005	CFM56-7B27
N809SY	B737-800	30683	03/2005	CFM56-7B27

2. Delta and MN hereby agree that N808SY and N809SY have certain parts and/or components that are not compatible with the other Aircraft in the Agreement and with the B737-800 aircraft in Delta’s fleet. Delta and MN each agree to work together to reach a mutually agreed upon process for managing the differences which may exist with respect to N808SY and N809SY.

3. Except as amended by this Amendment, all other provisions of the Agreement shall remain in full force and effect.

IN WITNESS WHEREOF, the parties have caused this Amendment to be executed by their duly authorized representatives on the date first written above.

MN AIRLINES, LLC

DELTA AIR LINES, INC.

By: /s/ Shaun P. Nugent  
Name: Shaun P. Nugent  
Title: Chief Executive Officer

By: /s/ Gary Swanson  
Name: Gary Swanson  
Title: Managing Director, Technical Sales





Delta Air Lines, Inc.  
 Department 460  
 Atlanta, Georgia 30320-6001

**Amendment  
 to  
 Technical Services Agreement**

This Amendment no. 3 ("Amendment") to the Inventory Support & Services Agreement Between Delta Air Lines, Inc ("Delta") and MN Airlines, LLC, ("Sun Country") dated October 8, 2003 (the "Agreement"), shall be effective as of 15th day of July, 2007 ("Effective Date").

WHEREAS, the parties have entered into the Agreement for the provision of certain inventory and maintenance support services from Delta to Sun Country; and

WHEREAS, the parties wish to amend the Agreement to add additional aircraft to the Agreement

NOW, THEREFORE, the parties hereto hereby agree as follows:

1. All capitalized terms used herein but not defined shall have the meaning ascribed to them in the Agreement.

The entire Agreement is hereby amended to include the following aircraft tail numbers to be included and covered under the Agreement;

Registration	Model	Serial #	Mfg. Date	Engine Type
N810SY	B737-800	29635	7/2007	CFM56-7B26
N811SY	B737-800	29660	8/2007	CFM56-7B26

2. Delta and Sun Country hereby agree that N810SY and N811SY have certain parts and/or components that are not compatible with the other Aircraft in the Agreement and with the B737-800 aircraft in Delta's fleet. Delta and Sun Country each agree to work together to reach a mutually agreed upon process for managing the differences which may exist with respect to N810SY and N811SY.

3. Except as amended by this Amendment, all other provisions of the Agreement shall remain in full force and effect.

IN WITNESS WHEREOF, the parties have caused this Amendment to be executed by their duly authorized representatives on the date first written above.

MN Airlines, LLC.

DELTA AIR LINES, INC.

By: /s/ Steven Speliman

Name: Steven Speliman

Title: CFO/COO

By: /s/ Jack Turnbull

Name: Jack Turnbull

Title: Director of Technical Sales and Marketing



Delta Air Lines, Inc.  
 Department 460  
 Atlanta, Georgia 30320-6001

MN Airlines, LLC  
 DBA Sun Country Airlines  
 1300 Mendota Heights Road  
 Mendota Heights, MN 55120  
 Attn: Tony Kubit

**Amendment No. 4  
 to  
 Technical Services Agreement**

This Amendment no. 4 ("Amendment") to the Inventory Support & Services Agreement Between Delta Air Lines, Inc ("Delta") and MN Airlines, LLC, ("Sun Country") dated October 8, 2003, (the "Agreement"), shall be effective as of 23rd day of May, 2008 ("Effective Date").

WHEREAS, the parties have entered into the Agreement for the provision of certain maintenance services to Sun Country; and

WHEREAS, the parties wish to amend the Agreement to allow for adding aircraft that are not currently covered by this Agreement;

NOW, THEREFORE, the parties hereto hereby agree as follows:

1. All capitalized terms used herein but not defined shall have the meaning ascribed to them in the Agreement.

The entire Agreement is hereby amended to include the following aircraft tail numbers to be included and covered under the Agreement;

Registration	Model	Serial #	Mfg. Date	Engine Type
737-7Q8	B737-700	S/N 30674	June 2004	CFM56-7B26

The PBTH agreement for this aircraft will be for a period of 12 months commencing on May 23, 2008 thru May 23, 2009 or at the time Sun Country ceases operation of this aircraft. The parts support will be on a limited basis as agreed to by both parties and established by a mutually agreed to parts list and a PBTH rate of \$98.20 per flight hour. The parts access fee will be the same as all other aircraft in the program: \$7500.00 per aircraft.

2. Except as amended by this Amendment, all other provisions of the Agreement shall remain in full force and effect.

IN WITNESS WHEREOF, the parties have caused this Amendment No. 4 to be executed by their duly authorized representatives on the date first written above.

MN Airlines, LLC.

DELTA AIR LINES, INC.

By: /s/ John Fredericksen  
Name: John Fredericksen  
Title: VP & General counsel

By: /s/ Jack Turnbull  
Name: Jack Turnbull  
Title: Vice President of Technical Sales



Delta Air Lines, Inc.  
Department 460  
Atlanta, Georgia 30320-6001

**Amendment No. 5**  
**to**  
**Technical Services Agreement**

This Amendment no. 5 ("Amendment") to the Inventory Support & Services Agreement Between Delta Air Lines, Inc ("Delta") and MN Airlines, LLC, ("Sun Country") dated October 8, 2003, (the "Agreement"), shall be effective as of the 4th day of June, 2008.

WHEREAS, the parties have entered into the Agreement for the provision of certain maintenance services to Sun Country; and

WHEREAS, the parties wish to amend the Agreement to allow for changes in term that is covered by this Agreement;

NOW, THEREFORE, the parties hereto hereby agree as follows:

1. All capitalized terms used herein but not defined shall have the meaning ascribed to them in the Agreement.

**2. TERM**

2.1 Term and Termination. The Agreement shall be extended to remain in force and effect until October 8, 2015. Except as specified in the following section, any Services in progress upon the expiration or termination hereof shall be completed subject to the terms of this Agreement and any payments due there for shall be made in accordance with the terms hereof, even if such Services extend beyond the expiration or termination of this Agreement.

2.2 At any time after seven (7) years from the Effective Date [October 8, 2003], either party may terminate this Agreement for convenience and without penalty or further obligation to the other party upon not less than one hundred eighty (180) days prior written notice to the other party.

Annex A

Cost per Flight Hour & Rate Adjustment

In conjunction with the extension in term, the net Hourly PBTH cost shall be reduced by 2% effective June 5, 2008.

3. Except as amended by this Amendment, all other provisions of the Agreement shall remain in full force and effect.

IN WITNESS WHEREOF, the parties have caused this Amendment to be executed by their duly authorized representatives on the date first written above.

MN Airlines, LLC.

DELTA AIR LINES, INC.

By: /s/ John S. Frederickson  
Name: John S. Frederickson  
Title: Vice President

By: /s/ Jack Turnbull  
Name: Jack Turnbull  
Title: Vice President of Technical Sales





**Amendment No. 7  
to  
Technical Services Agreement**

This Amendment no. 7 ("Amendment") to the Inventory Support & Services Agreement Between Delta Air Lines, Inc ("Delta") and MN Airlines, LLC, ("Sun Country") dated October 8, 2003, (the "Agreement"), shall be effective as of the 7th day of April, 2009 ("Effective Date").

WHEREAS, the parties have entered into the Agreement for the provision of certain maintenance services to Sun Country; and

WHEREAS, the parties wish to amend the Agreement to allow for changes in aircraft that are covered by this Agreement;

NOW, THEREFORE, the parties hereto hereby agree as follows:

1. All capitalized terms used herein but not defined shall have the meaning ascribed to them in the Agreement.
2. The Agreement is hereby amended to include the following aircraft tail number to be included and covered under the Agreement effective as of the 7th day of April, 2009;

Registration	Model	Serial #	Mfg. Date	Engine Type
N813SY	B737-8Q8	S/N 28237	Feb 2001	CFM56-7B26

3. The Agreement is hereby amended to remove the following aircraft tail number (the "Removed Aircraft") effective as of the 7th day of April, 2009 so that it is no longer covered under the Agreement;

Registration	Model	Serial #	Mfg. Date	Engine Type
N807SY	B737-8BK	S/N 33016	Oct 2004	CFM56-7B27

All amounts due for the Removed Aircraft up to its effective removal date shall be paid to Delta within thirty (30) days of the effective removal date.

4. Except as amended by this Amendment, all other provisions of the Agreement shall remain in full force and effect.

IN WITNESS WHEREOF, the parties have caused this Amendment to be executed by their duly authorized representatives on the date first written above.

MN Airlines, LLC.  
DBA Sun Country Airlines

DELTA AIR LINES, INC.

By: /s/ John Fredericksen  
Name: John Fredericksen  
Title: Vice President

By: /s/ Jack Turnbill  
Name: Jack Turnbill  
Title: Vice President of Technical Sales



**Amendment No. 8  
to  
Technical Services Agreement**

This Amendment no. 8 ("Amendment") to the Inventory Support & Services Agreement Between Delta Air Lines, Inc ("Delta") and MN Airlines, LLC, ("Sun Country") dated October 8,2003, (the "Agreement"), shall be effective as of the 1st day of May, 2009 ("Effective Date").

WHEREAS, the parties have entered into the Agreement for the provision of certain maintenance services to Sun Country; and

WHEREAS, the parties wish to amend the Agreement to allow for changes in aircraft that are covered by this Agreement;

NOW, THEREFORE, the parties hereto hereby agree as follows:

1. All capitalized terms used herein but not defined shall have the meaning ascribed to them in the Agreement.
2. The Agreement is hereby amended to remove the following aircraft tail number (the "Removed Aircraft") effective as of the 1st day of May, 2009 so that it is no longer covered under the Agreement;

Registration	Model	Serial #	Mfg. Date	Engine Type
N808SY	B737-8BK	S/N 33021	Mar 2005	CFM56-7B27

All amounts due for the Removed Aircraft up to its effective removal date shall be paid to Delta within thirty (30) days of the effective removal date.

3. Except as amended by this Amendment, all other provisions of the Agreement shall remain in full force and effect.

IN WITNESS WHEREOF, the parties have caused this Amendment to be executed by their duly authorized representatives on the date first written above.

MN Airlines, LLC.  
DBA Sun Country Airlines

DELTA AIR LINES, INC.

By: /s/ Tony Kubit  
Name: Tony Kubit  
Title: Director of Engineering

By: /s/ Jack Turnbull  
Name: Jack Turnbull  
Title: Vice President of Technical Sales







**Amendment No. 10  
to  
Technical Services Agreement**

This Amendment no. 10 (“Amendment”) to the Inventory Support & Services Agreement Between Delta Air Lines, Inc (“Delta”) and MN Airlines, LLC, (“Sun Country”) dated October 8, 2003, (the “Agreement”), shall be effective as of the 1st day of January, 2010.

WHEREAS, the parties have entered into the Agreement for the provision of certain maintenance services to Sun Country; and

WHEREAS, the parties wish to amend the Agreement to allow for changes in term that is covered by this Agreement;

NOW, THEREFORE, the parties hereto hereby agree as follows:

1. All capitalized terms used herein but not defined shall have the meaning ascribed to them in the Agreement.
2. Term and Termination  
The Agreement shall be extended to remain in force and effect until October 8, 2018. Except as specified in the following section, any Services in progress upon the expiration or termination hereof shall be completed subject to the terms of this Agreement and any payments due there for shall be made in accordance with the terms hereof, even if such Services extend beyond the expiration or termination of this Agreement.
3. Annex A  
Cost per Flight Hour Rate Adjustment  
In conjunction with the extension in term, the Hourly PBTH rate for aircraft with age greater than 60 months shall be reduced to \$130.53 effective January 1, 2010.  
Program rates shall be subject to escalation as outlined in the Agreement.
4. Delta TechOps shall have the exclusive right to submit a “best and final bid” for future aircraft airframe (hangar), aircraft modification, aircraft paint and engine maintenance services, in the event that Delta does not submit a winning bid in the first round of proposals.
5. Except as amended by this Amendment, all other provisions of the Agreement shall remain in full force and effect.

IN WITNESS WHEREOF, the parties have caused this Amendment to be executed by their duly authorized representatives on the date first written above.

MN AIRLINES, LLC.

By: /s/ John S. Fredericksen  
Name: John S. Fredericksen  
Title: Vice President

DELTA AIR LINES, INC.

By: /s/ Jack Turnbill  
Name: Jack Turnbill  
Title: Vice President



**Amendment No. 11  
to  
Technical Services Agreement**

This Amendment no. 11 ("Amendment") to the Inventory Support & Services Agreement Between Delta Air Lines, Inc ("Delta") and MN Airlines, LLC, ("Sun Country") dated October 8, 2003, (the "Agreement"), shall be effective as of the 1st day of May, 2010 ("Effective Date").

WHEREAS, the parties have entered into the Agreement for the provision of certain maintenance services to Sun Country; and

WHEREAS, the parties wish to amend the Agreement to allow for changes in aircraft that are covered by this Agreement;

NOW, THEREFORE, the parties hereto hereby agree as follows:

1. All capitalized terms used herein but not defined shall have the meaning ascribed to them in the Agreement.
2. The Agreement is hereby amended to include the following aircraft tail number to be included and covered under the Agreement effective as of the 1st day of June, 2010;

Registration	Model	Serial #	Mfg. Date	Engine Type
N712SY	B737-7Q8	S/N 28219	Jan 1999	CFM56-7B22

3. The Agreement is hereby amended to remove the following aircraft tail number (the "Removed Aircraft") effective as of the 1st day of May, 2010 so that it is no longer covered under the Agreement;

Registration	Model	Serial #	Mfg. Date	Engine Type
N811SY	B737-8BK	S/N 29660	Aug 2007	CFM56-7B26

All amounts due for the Removed Aircraft up to its effective removal date shall be paid to Delta within thirty (30) days of the effective removal date.

4. Except as amended by this Amendment, all other provisions of the Agreement shall remain in full force and effect.

IN WITNESS WHEREOF, the parties have caused this Amendment to be executed by their duly authorized representatives on the date first written above.

MN Airlines, LLC.  
DBA Sun Country Airlines

DELTA AIR LINES, INC.

By: /s/ John Fredericksen  
Name: John Fredericksen  
Title: VP General Counsel

By: /s/ Jack Turnbull  
Name: Jack Turnbull  
Title: Vice President of Technical Sales



**Amendment No. 11  
to  
Technical Services Agreement**

This Amendment no. 11 (“Amendment”) to the Inventory Support & Services Agreement Between Delta Air Lines, Inc (“Delta”) and MN Airlines, LLC, (“Sun Country”) dated October 8, 2003, (the “Agreement”), shall be effective as of the 1st day of May, 2010 (“Effective Date”).

WHEREAS, the parties have entered into the Agreement for the provision of certain maintenance services to Sun Country; and

WHEREAS, the parties wish to amend the Agreement to allow for changes in aircraft that are covered by this Agreement;

NOW, THEREFORE, the parties hereto hereby agree as follows:

1. All capitalized terms used herein but not defined shall have the meaning ascribed to them in the Agreement.
2. The Agreement is hereby amended to include the following aircraft tail number to be included and covered under the Agreement effective as of the 1st day of June, 2010;

Registration	Model	Serial #	Mfg. Date	Engine Type
N712SY	B737-7Q8	S/N 28219	Jan 1999	CFM56-7B22

3. The Agreement is hereby amended to remove the following aircraft tail number (the “Removed Aircraft”) effective as of the 1st day of May, 2010 so that it is no longer covered under the Agreement;

Registration	Model	Serial #	Mfg. Date	Engine Type
N811SY	B737-8BK	S/N 29660	Aug 2007	CFM56-7B26

All amounts due for the Removed Aircraft up to its effective removal date shall be paid to Delta within thirty (30) days of the effective removal date.

4. Except as amended by this Amendment, all other provisions of the Agreement shall remain in full force and effect.

IN WITNESS WHEREOF, the parties have caused this Amendment to be executed by their duly authorized representatives on the date first written above.

MN Airlines, LLC.  
DBA Sun Country Airlines

DELTA AIR LINES, INC.

By: /s/ John Fredericksen  
Name: John Fredericksen  
Title: VP General Counsel

By: /s/ Jack Turnbill  
Name: Jack Turnbill  
Title: Vice President of Technical Sales



**Amendment No. 11  
to  
Technical Services Agreement**

This Amendment no. 11 ("Amendment") to the Inventory Support & Services Agreement Between Delta Air Lines, Inc ("Delta") and MN Airlines, LLC, ("Sun Country") dated October 8,2003, (the "Agreement"), shall be effective as of the 1st day of May, 2010 ("Effective Date").

WHEREAS, the parties have entered into the Agreement for the provision of certain maintenance services to Sun Country; and

WHEREAS, the parties wish to amend the Agreement to allow for changes in aircraft that are covered by this Agreement;

NOW, THEREFORE, the parties hereto hereby agree as follows:

1. All capitalized terms used herein but not defined shall have the meaning ascribed to them in the Agreement.
2. The Agreement is hereby amended to include the following aircraft tail number to be included and covered under the Agreement effective as of the 1st day of June, 2010;

Registration	Model	Serial #	Mfg. Date	Engine Type
N712SY	B737-7Q8	S/N 28219	Jan 1999	CFM56-7B22

3. The Agreement is hereby amended to remove the following aircraft tall number (the "Removed Aircraft") effective as of the 1st day of May, 2010 so that it is no longer covered under the Agreement;

Registration	Model	Serial #	Mfg. Date	Engine Type
N811SY	B737-8BK	S/N 29660	Aug 2007	CFM56-7B26

All amounts due for the Removed Aircraft up to its effective removal date shall be paid to Delta within thirty (30) days of the effective removal date.

4. Except as amended by this Amendment, all other provisions of the Agreement shall remain in full force and effect.

IN WITNESS WHEREOF, the parties have caused this Amendment to be executed by their duly authorized representatives on the date first written above.

MN Airlines, LLC.  
DBA Sun Country Airlines

DELTA AIR LINES, INC.

By: /s/ John Fredericksen  
Name: John Fredericksen  
Title: VP General Counsel

By: /s/ Jack Turnbull  
Name: Jack Turnbull  
Title: Vice President of Technical Sales



**Amendment No. 13  
to  
Technical Services Agreement**

This Amendment no. 13 ("Amendment") to the Inventory Support & Services Agreement Between Delta Air Lines, Inc ("Delta") and MN Airlines, LLC, ("Sun Country") dated October 8, 2003, (the "Agreement"), shall be effective as of the 1st day of November, 2011 ("Effective Date").

WHEREAS, the parties have entered into the Agreement for the provision of certain maintenance services to Sun Country; and

WHEREAS, the parties wish to amend the Agreement to allow for changes in aircraft that are covered by this Agreement;

NOW, THEREFORE, the parties hereto hereby agree as follows:

1. All capitalized terms used herein but not defined shall have the meaning ascribed to them in the Agreement.
2. The Agreement is hereby amended to include the following aircraft tail number to be included and covered under the Agreement effective as of the 1st day of May, 2011;

Registration	Model	Serial #	Variable	Mfg. Date	Engine Type
N713SY	B737-700	S/N 30635	YA 323	Nov 2000	CFM56-7B
N817SY	B737-800	S/N 30392	YC 082	Apr 2001	CFM56-7B

4. Except as amended by this Amendment, all other provisions of the Agreement shall remain in full force and effect.

IN WITNESS WHEREOF, the parties have caused this Amendment to be executed by their duly authorized representatives on the date first written above.

MN Airlines, LLC.  
DBA Sun Country Airlines

DELTA AIR LINES, INC.

By: /s/ John Fredericksen  
Name: John Fredericksen  
Title: VP General Counsel

By: /s/ Jack Turnbill  
Name: Jack Turnbill  
Title: Vice President of Technical Sales



**Amendment No. 14  
to  
Technical Services Agreement**

This Amendment no. 14 (“Amendment”) to the Inventory Support & Services Agreement between Delta Air Lines, Inc (“Delta”) and MN Airlines, LLC (“Sun Country”) dated October 8, 2003, (the “Agreement”), shall be effective as of the 28th day of May, 2013 (“Effective Date”).

WHEREAS, the parties have entered into the Agreement for the provision of certain maintenance services to Sun Country; and

WHEREAS, the parties wish to amend the Agreement to allow for changes in aircraft that are covered by this Agreement;

NOW, THEREFORE, the parties hereto hereby agree as follows:

1. All capitalized terms used herein but not defined shall have the meaning ascribed to them in the Agreement.
2. The Agreement is hereby amended to include the following aircraft tail number to be included and covered under the Agreement effective as of the 1st day of June, 2013:

Registration	Model	Serial #	Variable	Mfg. Date	Engine Type
N716SY	B737-7Q8	S/N 30629	YA356	Nov 2001	CFM56-7B

The following aircraft tail number shall be removed from coverage under the Agreement, (“the Removed Aircraft”) effective as of the 31<sup>st</sup> day of May, 2013

Registration	Model	Serial #	Variable	Mfg. Date	Engine Type
N806SY	B737-8BK	S/N 28215		Aug 1998	CFM56-7B

3. Except as amended by this Amendment, all other provisions of the Agreement shall remain in full force and effect.

IN WITNESS WHEREOF, the parties have caused this Amendment to be executed by their duly authorized representatives as of the Effective Date.

MN Airlines, LLC.  
dba Sun Country Airlines

DELTA AIR LINES, INC.

By: /s/ John Fredericksen  
Name: John Fredericksen  
Title: President/CEO

By: /s/ Peter T. Turner  
Name: Peter T. Turner  
Title: Vice President – MRO Services



**Amendment No. 15  
to  
Technical Services Agreement**

This Amendment no. 15 (“Amendment”) to the Inventory Support & Services Agreement Between Delta Air Lines, Inc (“Delta”) and MN Airlines, LLC, (“Sun Country”) dated October 8, 2003, (the “Agreement”), shall be effective as of the 23rd day of July, 2014 (“Effective Date”).

WHEREAS, the parties have entered into the Agreement for the provision of certain maintenance services to Sun Country; and

WHEREAS, the parties wish to amend the Agreement to allow for changes in aircraft that are covered by this Agreement;

NOW, THEREFORE, the parties hereto hereby agree as follows:

1. All capitalized terms used herein but not defined shall have the meaning ascribed to them in the Agreement.
2. The Agreement is hereby amended to update the list of aircraft tail numbers to be included and covered under the Agreement effective as of the 1st day of July, 2014;

<u>Registration</u>	<u>Model</u>	<u>Serial Nbr.</u>	<u>Variable</u>	<u>Mfg. Date</u>	<u>Engine Type</u>
N710SY	B737-7	S/N 30241	YB109	Dec. 2001	CFM56-7
N711SY	B737-7	S/N 30245	YB110	Jan. 2002	CFM56-7
N712SY	B737-7	S/N 28219	YA321	Jan. 1999	CFM56-7
N713SY	B737-7	S/N 30635	YA323	Nov. 2000	CFM56-7
N714SY	B737-7	S/N 33786	YB854	Nov. 2003	CFM56-7
N715SY	B737-7	S/N 33787	YB856	Dec. 2003	CFM56-7
N716SY	B737-7	S/N 30629	YA356	Nov. 2001	CFM56-7
N801SY	B737-7	S/N 30332	YC152	Feb. 2001	CFM56-7
N804SY	B737-7	S/N 30689	YC155	Aug. 2001	CFM56-7
N805SY	B737-7	S/N 30032	YC156	Nov. 2001	CFM56-7
N808SY	B737-7	S/N 33021	YJ936	Mar. 2005	CFM56-7
N809SY	B737-7	S/N 30683	YK132	Mar. 2005	CFM56-7
N813SY	B737-7	S/N 28237	YC104	Feb. 2001	CFM56-7
N814SY	B737-7	S/N 30620	YD251	Oct. 2001	CFM56-7
N815SY	B737-7	S/N 30623	YD253	Oct. 2001	CFM56-7
N816SY	B737-7	S/N 30637	YC113	Mar. 2001	CFM56-7
N817SY	B737-7	S/N 30392	YC082	Apr. 2001	CFM56-7
N818SY	B737-7	S/N 29646	YJ976	Jun. 2007	CFM56-7
N819SY	B737-7	S/N 34254	YJ005	Mar. 2006	CFM56-7

4. Except as amended by this Amendment, all other provisions of the Agreement shall remain in full force and effect.

IN WITNESS WHEREOF, the parties have caused this Amendment to be executed by their duly authorized representatives on the date first written above.



MN Airlines, LLC.  
DBA Sun Country Airlines

DELTA AIR LINES, INC.

By: /s/ Craig Hirman 9/4/2014  
Name: Craig Hirman  
Title: Sr. Director – Airframe Maintenance & Engineering

By: /s/ Peter T. Turner  
Name: Peter T. Turner  
Title: Vice President – MRO Services



**Amendment No. 16  
to  
Technical Services Agreement**

This Amendment no. 16 (“Amendment”) to the Inventory Support & Services Agreement Between Delta Air Lines, Inc. (“Delta”) and MN Airlines, LLC d/b/a Sun Country Airlines (“Sun Country”) dated October 8, 2003, (the “Agreement”), shall be effective as of the 20th day of March, 2015 (“Effective Date”).

WHEREAS, the parties have entered into the Agreement for the provision of certain maintenance services to Sun Country; and

WHEREAS, the parties wish to amend the Agreement to allow for changes in aircraft that are covered by this Agreement;

NOW, THEREFORE, the parties hereto hereby agree as follows:

1. All capitalized terms used herein but not defined shall have the meaning ascribed to them in the Agreement.
2. The Agreement is hereby amended to update the list of aircraft tail numbers to be included and covered under the Agreement effective as of the 1st day of January, 2015;

<u>Registration</u>	<u>Model</u>	<u>Serial Nbr.</u>	<u>Variable</u>	<u>Mfg. Date</u>	<u>Engine Type</u>
N710SY	B 737-7	S/N 30241	YB109	Dec. 2001	CFM56-7
N711SY	B 737-7	S/N 30245	YB110	Jan. 2002	CFM56-7
N712SY	B 737-7	S/N 28219	YA321	Jan. 1999	CFM56-7
N713SY	B 737-7	S/N 30635	YA323	Nov. 2000	CFM56-7
N714SY	B 737-7	S/N 33786	YB854	Nov. 2003	CFM56-7
N715SY	B 737-7	S/N 33787	YB856	Dec. 2003	CFM56-7
N716SY	B 737-7	S/N 30629	YA356	Nov. 2001	CFM56-7
N801SY	B 737-8	S/N 30332	YC152	Feb. 2001	CFM56-7
N804SY	B 737-8	S/N 30689	YC155	Aug. 2001	CFM56-7
N805SY	B 737-8	S/N 30032	YC156	Nov. 2001	CFM56-7
N808SY	B 737-8	S/N 33021	YJ936	Mar. 2005	CFM56-7
N809SY	B 737-8	S/N 30683	YK132	Mar. 2005	CFM56-7
N813SY	B 737-8	S/N 28237	YC104	Feb. 2001	CFM56-7
N814SY	B 737-8	S/N 30620	YD251	Oct. 2001	CFM56-7
N815SY	B 737-8	S/N 30623	YD253	Oct. 2001	CFM56-7
N816SY	B 737-8	S/N 30637	YC113	Mar. 2001	CFM56-7
N817SY	B 737-8	S/N 30392	YC082	Apr. 2007	CFM56-7
N818SY	B 737-8	S/N 29646	YJ976	Jun. 2007	CFM56-7
N819SY	B 737-8	S/N 34254	YJ005	Mar. 2006	CFM56-7
N820SY	B 737-8	S/N 39951	YS456	Nov. 2014	CFM56-7
N821SY	B 737-8	S/N 39952	YS457	Dec. 2014	CFM56-7

4. Except as amended by this Amendment, all other provisions of the Agreement shall remain in full force and effect.

IN WITNESS WHEREOF, the parties have caused this Amendment to be executed by their duly authorized representatives on the date first written above.

MN Airlines, LLC  
d/b/a Sun Country Airlines

DELTA AIR LINES, INC.

By: /s/ Craig Hirman 3/20/2015  
Name: Craig Hirman  
Title: Sr. Director – Aircraft Maintenance & Engineering

By: /s/ Jack Arehart  
Name: Jack Arehart  
Title: President – MRO Services

**Amendment No. 17**  
**to**  
**Inventory Support & Services Agreement**

This Amendment No. 17 (“Amendment”) to the Inventory Support & Services Agreement between Delta Air Lines, Inc (“Delta”) and MN Airlines, LLC (“MN Airlines”) dated both October 8, 2003 and October 27, 2003, (as amended, the “Agreement”), shall be effective as of the April 1, 2018 (“Effective Date”).

WHEREAS, the parties have entered into the Agreement for the provision of certain maintenance services to MN Airlines: and

WHEREAS, the parties wish to amend the Agreement;

NOW, THEREFORE, in consideration of the mutual covenants hereinafter set forth and other good and valuable consideration, the receipt and sufficiency of which are hereby acknowledged, the parties hereby agree to amend the Agreement as follows:

1. All capitalized terms used herein but not defined shall have the meaning ascribed to them in the Agreement.
2. The first sentence of Section 2.1 is hereby deleted in its entirety and replaced with the following language:

This Agreement shall become effective on the date first written above (the “Effective Date”) and shall remain in effect until terminated by either party as provided for herein (the “Term”).
3. Section 2.2 is hereby deleted in its entirety and replaced with the following language:
  - 2.2. Either party may terminate this Agreement for convenience and without penalty or further obligation to the other party (except with respect to obligations incurred prior to the effective date of termination) upon not less than one hundred eighty (180) days prior written notice to the other party, provided that the effective date of termination shall be on or after April 7, 2022.
4. Section 4.1 is hereby deleted in its entirety and replaced with the following language:
  - 4.1. MN Airlines shall deliver Components Ex-Works (International Chamber of Commerce, Incoterms 2010), Delta’s Facility at MSP airport or a mutually agreed Delta-staffed maintenance location, whereby MN Airlines fulfills the obligations of seller and Delta fulfills the obligations of buyer. Delta shall deliver the Components DDP (Delivered Duty Paid, International Chamber of Commerce, Incoterms 2010) Delta’s Facility at MSP airport or a mutually agreed Delta-staffed maintenance location, whereby MN Airlines fulfills the obligations of buyer and Delta fulfills the obligations of seller.

5. Sections 5.1 and 5.2 are hereby deleted in their entirety and replaced with the following language:

5.1 IN NO EVENT WILL EITHER PARTY BE LIABLE TO THE OTHER FOR ANY INDIRECT, INCIDENTAL, PUNITIVE, SPECIAL, OR CONSEQUENTIAL DAMAGES OF ANY KIND, INCLUDING BUT NOT LIMITED TO LOST REVENUES, PROFITS, OR GOODWILL, FOR ANY MATTER ARISING OUT OF OR IN CONNECTION WITH THE PERFORMANCE OR NONPERFORMANCE OF THIS AGREEMENT, WHETHER SUCH LIABILITY IS ASSERTED ON THE BASIS OF CONTRACT, TORT, STRICT LIABILITY OR OTHERWISE, EVEN IF A PARTY HAS BEEN ADVISED OF THE POSSIBILITY OF SUCH DAMAGES. THE FOREGOING EXCLUSIONS SHALL NOT APPLY TO EITHER PARTY'S LIABILITY TO THE OTHER FOR SUCH PARTY'S VIOLATION OF THE CONFIDENTIALITY OBLIGATIONS UNDER THIS AGREEMENT.

5.2 IN NO EVENT SHALL DELTA'S LIABILITY TO MN AIRLINES ARISING OUT OF OR IN CONNECTION WITH THE PERFORMANCE OR NONPERFORMANCE OF THIS AGREEMENT, WHETHER SUCH LIABILITY IS ASSERTED ON THE BASIS OF CONTRACT, WARRANTY, TORT OR OTHERWISE, EXCEED FOR ANY CLAIM THE GREATER OF (A) THE COST ACTUALLY PAID BY MN AIRLINES UNDER THIS AGREEMENT FOR THE SPECIFIC SERVICES GIVING RISE TO THE CLAIM AND (B) THE REPLACEMENT VALUE OF THE SPECIFIC PIECE PART GIVING RISE TO THE CLAIM.

6. Section 8.5 is hereby deleted in its entirety and replaced with the following language:

8.5 This Agreement shall be governed by and construed in accordance with the laws of the State of Delaware, regardless of its conflicts of laws rules.

7. The Section 11 notice address for MN Airlines is updated to: 1300 Corporate Center Curve, Eagan, Minnesota 55121.

8. The section titled "Method of Shipment and Costs" in Annex A of the Agreement is hereby deleted in its entirety.

9. The definition of "Common Components" is hereby deleted in its entirety and replaced with the following language:

"Common Components" means:

- (a) Any Component that is: (i) recognized by Delta to be form, fit and function interchangeable with those like-Components on Delta B737 Next Generation aircraft and (ii) is a rotatable regularly stocked by Delta or a Delta-designated key repairable item;
- (b) Any Component listed in the table below that is: (i) recognized by Delta to be form, fit and function interchangeable with those like-Components on aircraft then-owned or operated by Delta and (ii) is a rotatable regularly stocked by Delta or a Delta-designated key repairable item (the "Additional Components Table"); and
- (c) Any other Component mutually agreed by Delta and MN Airlines in writing to be a Common Component.

**Additional Components Table**

<b>Code</b>	<b>ATA</b>	<b>PNR</b>	<b>Part Description</b>
HON	23	064-50000-0110	TRANSCEIVER - VHF COMMUNICATIONS
HON	34	071-50001-8102	ANTENNA
HON	34	69000940-102	COMPUTER - ENHANCED GND PROXIMITY WARNING
HON	34	69000940-104	COMPUTER - ENHANCED GND PROXIMITY WARNING
HON	34	965-0976-003-212-212	COMPUTER - ENHANCED GND PROXIMITY WARNING
HON	34	965-0976-003-222-222	COMPUTER - ENHANCED GND PROXIMITY WARNING
HON	34	965-0976-003-232-232	COMPUTER - ENHANCED GND PROXIMITY WARNING
HON	34	965-1690-055	COMPUTER - ENHANCED GND PROXIMITY WARNING
HON	34	066-50000-2220	COMPUTER - TCAS
HON	34	066-50000-2221	COMPUTER - TCAS
HON	34	965-0976-003-216-216	COMPUTER, (EGPWS) MKV ENHANCED GROUND PR
HON	34	930-3000-001	DRIVE - ANTENNA, WEATHER RADAR
HON	34	066-50013-0101	INTERROGATOR - DME
HON	34	071-01503-2601	PANEL - DUAL ATC/TRAFFIC ALERT AND COLLISION AVOIDANCE SYS CONT
HON	34	066-50014-0101	RECEIVER - AUTO DIR FINDER
HON	34	066-50012-0101	RECEIVER - VOR/MB
HON	34	066-50007-0101	TRANSCEIVER - LRRA
HON	34	066-50007-0531	TRANSCEIVER - LRRA
HON	34	066-50008-0406	TRANSCEIVER - WEATHER RADAR
HON	34	066-01127-1602	TRANSPONDER - ATC
HON	34	822-1338-005	TRANSPONDER - ATC
HON	34	822-1338-205	TRANSPONDER - ATC

10. The following language is hereby added as a new section at the end of Annex A, immediately preceding Annex A1:

**Assessment of Common Components**

As requested from time to time by MN Airlines, Delta will analyze the component listing of any Aircraft that MN Airlines is interested in leasing and provide MN Airlines with a report identifying the components within such Aircraft that would constitute Common Components under this Agreement. Delta shall use commercially reasonable efforts to provide any such report within seven (7) business days of receiving the necessary information from MN Airlines that is required to provide the report.

## Engineering Support Services

To the extent necessary to support the scope of services as set forth in this Annex A, Delta will provide the following engineering support services:

- General Shop Support – Includes developing 1-off repairs as well as multi-use repairs for a particular Component.
- Outside Vendor Shop Support – Delta will provide engineering oversight on Components that are sent out to outside vendors.
- Component Configuration – Review and approve implementation of Service Bulletins (SB) as needed.
- Reliability – From internally developed & managed reliability (RI) and Component (CPI) indexes, Delta will monitor and investigate reliability drivers on components.

Delta acknowledges that MN Airlines may at some point in the future have a capability of performing all engineering support services in-house. In such event, to the extent these engineering support services are redundant with those being provided by MN Airlines in-house, the parties shall discuss in good faith the reduction or removal of the engineering support services from this Annex A and a commensurate, pro-rata reduction or removal of the associated fee set forth in Section 2 of Annex A2.

## Supply Response Time

The Supply Response Time commitment from Delta for Common Components shall be as follows:

<b>Situation and Component Category</b>	<b>Supply Response Time</b>	<b>Achievement of Supply Response Time (based on rolling 3-month average)</b>
AOG Aircraft due to ESS 1 Component	No more than 3 hours between receipt of request and Dispatch *	96%
AOG Aircraft due to Component that is in stock at Delta's MSP facility	No more than 3 hours between receipt of request and available for MN Airlines pick-up	96%
All other situations	No more than 12 hours between receipt of request and Dispatch *	90%

\* Dispatch = MN Airlines is notified of Delta flight number and AWB that the requested Component is booked on or that requested Component is available for pickup at a Delta facility if part is being shipped by MN Airlines.

For purposes of this Section, "ESS" means the Essentiality Code for a particular Component, as set forth in the applicable Boeing Aircraft manual.

Delta shall provide MN Airlines with a report of Delta's achievement of the Supply Response Time for each category at each quarterly business review meeting. In addition, the then-current rate of Delta's achievement of the Supply Response Time for each category shall be available for MN Airlines review within the Integrated Exchange Website (IEW).

In the event Delta fails to meet the applicable Supply Response Time for any category for any reason other than Excusable Delay (as set forth in Section 6 of the Agreement) or a delay caused by MN Airlines, and MN Airlines has an Aircraft that will be prohibited from flying a scheduled service solely due to Delta not meeting Supply Response Time fat a specific Component within such category (the "AOG-Causing Part"), MN Airlines shall provide Delta with notice of such situation (the "AOG Notice") and provide Delta with an opportunity to meet MN Airlines' reasonable requirements for delivery of the AOG-Causing Part. If Delta fails to meet such requirements, then Delta will provide MN Airlines with a credit against future invoices in an amount equal to the actual commercially reasonable cost paid by MN Airlines to a third party for the rent of a replacement Component for the period of time between the delivery of the AOG Notice and MN Airlines' subsequent receipt of the AOG-Causing Part from Delta. The foregoing remedy shall be Delta's sole obligation and MN Airlines' sole remedy for failure to meet any Supply Response Time.

#### **Miscellaneous Services**

As requested by MN Airlines, Delta will use commercially reasonable efforts to provide additional value-added services (such as common procurement initiatives; access to available Component lease units; tooling support; and prognostic, predictive maintenance and sensor initiatives) to MN Airlines to the extent that such services are directly related to the services set forth in this Annex A and can be performed by Delta without incurring incremental third party costs. Certain additional value-added services may be subject to additional applicable terms and conditions.

11. Annex A1 is hereby deleted in its entirety and replaced with a new Annex A1, which is attached hereto as Attachment 1.
12. Annex A2 is hereby deleted in its entirety and replaced with a new Annex A2, which is attached hereto as Attachment 2.
13. Annex A3 is hereby deleted in its entirety and replaced with a new Annex A3, which is attached hereto as Attachment 3.
14. Except as amended by this Amendment, all other provisions of the Agreement shall remain in full force and effect.

[Signatures on Following Page]



IN WITNESS WHEREOF, the parties have caused this Amendment to be executed by their duly authorized representatives as of the Effective Date.

MN AIRLINES, LLC  
dba Sun Country Airlines

DELTA AIR LINES, INC.

By: /s/ Jude Bricker  
Name: Jude Bricker  
Title: President and CEO

By: /s/ Sonny Stern  
Name: Sonny Stern  
Title: MD - MRO Services

Attachment 1 to Amendment

ANNEX A1

Description of Aircraft

<u>Registration #</u>	<u>Serial Number</u>	<u>Date of Manufacture</u>	
N710SY	30241	Dec-2001	
N711SY	30245	Jan-2002	
N713SY	30635	Nov-2000	
N716SY	30629	Dec-2001	
N801SY	30332	Feb-2001	
N804SY	30689	Aug-2001	
N805SY	30032	Nov-2001	
N808SY	33021	Mar-2005	
N809SY	30683	Mar-2005	
N813SY	28237	Feb-2001	
N814SY	30620	Oct-2001	
N815SY	30623	May-2002	
N816SY	30637	Mar-2001	
N817SY	30392	Apr-2001	
N819SY	34254	Mar-2006	
N820SY	39951	Nov-2014	
N821SY	39952	Dec-2014	
N822SY	33017	Oct-2004	
N823SY	33971	Dec-2001	
N824SY	33976	Jun-2005	
N825SY	34410	April 2006	
N826SY	34411	May 2006	
N827SY	34412	May 2006	
N828SY	34413	June 2006	
N829SY	34414	June 2006	
N830SY	28249	May 2002	Delivery Oct. 2018
N831SY	30706	August 2001	Delivery Oct. 2018

In the event MN Airlines adds an additional aircraft to the fleet of Aircraft, that is reasonably determined by Delta to cause a material increase to Delta's cost to provide the Services (as measured on a per Aircraft basis), Delta reserves the right to adjust the PBTH Rate for that particular additional aircraft upon thirty (30) days' advance written notice. During such thirty (30) day notice period, upon request from MN Airlines, the parties shall negotiate in good faith to determine an alternative way of compensating Delta for the increase in cost caused by the particular additional Aircraft (such as a one-time payment from MN Airlines), provided that if mutual agreement on such alternative is not reached by the parties, the increased rate shall go into effect as of the end of such thirty (30) day period for that particular aircraft.

Attachment 2 to Amendment

ANNEX A2

Charges and Payment Terms

**1. Component Access and Exchange Flat Rates**

Delta shall charge MN Airlines and MN Airlines shall pay to Delta a flat monthly fee for Component access and exchange. Such fee shall be computed monthly by multiplying the number of Aircraft covered under this Agreement times the applicable flat fee set forth in the table below:

	<u>Total number of Aircraft covered by this Agreement: 0-30</u>	<u>Total number of Aircraft covered by this Agreement: 31-40</u>	<u>Total number of Aircraft covered by this Agreement: 41-50</u>	<u>Total number of Aircraft covered by this Agreement: 51 or more</u>
Component Access and Exchange – Flat Rate (per Aircraft/per month)	\$ 3,500	\$ 3,235	\$ 2,752	\$ 2,296

Such payment shall be made in accordance with Section 3.2. The rate for Component access and exchange shall be calculated on the last day of each month. For Aircraft introduced into or removed from MN Airlines' fleet during any particular month, the number of Aircraft considered in operation for that particular month shall be pro-rated based on the percentage of days that month such Aircraft has spent in service. Use of an Aircraft for any portion of a calendar day, local Aircraft time, constitutes use of the Aircraft for that day, for purposes of this section. The Aircraft is considered used if it is operated for any purpose, whether revenue, charter, training, promotional or non-revenue flying.

**2. Engineering Support Services Flat Rate**

Subject to Section 10 of this Amendment, Delta shall charge MN Airlines and MN Airlines shall pay to Delta a flat monthly fee of \$25,000 for the engineering support services described in Annex A. Such payment shall be made in accordance with Section 3.2.

**3. PBTH Rates**

Delta shall charge MN Airlines and MN Airlines shall pay to Delta a fee each month based on the applicable power-by-the-hour rate set forth below (the "PBTH Rate"), as compensation for Services which are described herein as being provided on a power-by-the-hour basis. Each calendar month during the Term, Delta shall invoice to MN Airlines an amount equal to the product of applicable PBTH Rate times the total number of Flight Hours for all Aircraft during such month. MN Airlines shall report to Delta by no later than the third business day of each month the total number of Flight Hours for all Aircraft for the preceding month. MN Airlines shall allow Delta representatives to inspect its operating records with respect to the Aircraft to verify the accuracy of the Flight Hour information.

Valid prior to October 9, 2018:

<u>Aircraft age at time of invoice</u>	<u>0 to 36 months</u>	<u>37 to 60 months</u>	<u>61 or more months</u>
PBTH Rate	\$ 66.51	\$ 112.66	\$ 148.40

Valid on and after October 9, 2018:

<u>Aircraft age at time of invoice</u>	<u>0 to 24 months</u>	<u>25 to 36 months</u>	<u>37 to 48 months</u>	<u>49 or more months</u>
PBTH Rate	\$ 15.93	\$ 25.99	\$ 70.42	\$ 83.83

Aircraft age, for purposes of determining the applicable PBTH Rate, is based on the number of months elapsed since the delivery of the Aircraft in new condition by the original equipment manufacturer to the initial owner or operator.

Should Delta and MN Airlines enter into an agreement for the provisioning of engine maintenance services on MN Airlines' CFM56-7 aircraft engines by Delta on an exclusive basis, Delta will, in good faith, re-evaluate the above rate in an effort to provide MN Airlines with a more favorable rate.

#### **4. Minimum Annual Flight Cycles**

The parties agree that the commercial terms of this Agreement are premised on the operation of each Aircraft for at least 3,000 Flight Hours per year, measured on an annual basis (the "Minimum Annual Flight Hours"), provided, however, that the measurement period for 2018 shall be from October 9 to December 31 and the Minimum Annual Flight Hours for 2018 shall be prorated accordingly, resulting in 689 Flight Hours per aircraft. As a result, MN Airlines agrees to compensate Delta for any difference between actual utilization of the Aircraft and the Minimum Annual Flight Hours in accordance with this Section. On January 1 of each calendar year during the Term beginning January 1, 2019, and on the date of expiration or termination of the Agreement, Delta shall invoice MN Airlines for an Annual Additional Payment for the immediately preceding calendar year for each Aircraft, calculated on a per Aircraft basis as follows (and prorated for any partial years):

Annual Additional Payment per Aircraft = applicable PBTH Rate for the measurement period\* (3,000 – actual Flight Hours for such Aircraft during the measurement period)

If the actual Flight Hours for any Aircraft during the measurement period is equal to or greater than 3,000, then the Annual Additional Payment for such Aircraft is 0.

For purposes of determining the Annual Additional Payment, Flight Hours may not be carried over from a previous year or carried over from Aircraft to Aircraft. For clarity, MN Airlines shall not receive a credit or refund for any Aircraft that exceeds 3,000 Flight Hours per calendar year. The Minimum Annual Flight Hours for any Aircraft that was added to the MN Airlines fleet during the Term shall be prorated for partial calendar years based on the date that such Aircraft began commercial service as part of the MN Airlines fleet.

#### **5. Time & Material Rates**

All services performed by Delta outside of the scope of the PBTH Rate shall be charged to MN Airlines on a time and materials basis in accordance with the rates set forth below (the "Delta T&M Rates"):

- a. \$122.42 per hour for mechanics and inspectors.
- b. \$189.78 per hour for engineers and analysts.

- c. New material at Delta's cost plus twelve (12%) percent with a per item cap on the markup of \$1,711.21 and a per line item cap on the markup of \$3,422.41
- d. Used/serviceable material at 75% of manufacturer's then-current list price with no markup.
- e. MN Airlines-supplied parts at 5% of MN Airlines' cost up to a maximum of \$342.24. Parts or kits provided directly by the original equipment manufacturer at no charge would not be subject to this handling fee.
- f. Outside repair at Delta's invoiced cost plus 8%.
- g. Consumable miscellaneous shop supplies will be provided at no charge.

#### **6. MN Airlines Delay Charges**

For every day beyond the fifth Day that MN Airlines retains a removed Component or fails to provide the required data for such Component, Delta will charge MN Airlines a daily fee representing a percentage of the manufacturer's current list price, computed cumulatively as follows: (i) 0.5% per day for days 5 through 10, then: (ii) 2% per day for days 11 through 20, then; (iii) 3% per day for days 21 through 30, then; (iv) 4% per day from days 31 through 45 or until return. After day 45 the Component will be considered lost and MN Airlines will be invoiced for all accumulated late charges and OEM current list price or Delta's actual replacement cost, whichever is greater.

#### **7. Invoices**

Invoices will be addressed and sent to MN Airlines at the following address:

MN Airlines, LLC  
1300 Corporate Center Curve  
Eagan, MN 55121

Attn: Accounts Payable

MN Airlines shall pay such invoices in full, without setoff or withholding, in accordance with the terms of the Agreement.

Attachment 3 to Amendment

ANNEX A3

Escalation

The PBTH Rate and the Delta T&M Rates are expressed in January 2018 United States dollars and are subject to escalation on January 1 of each year during the Term, beginning on January 1, 2019, as set forth in this Annex A3. All escalations are cumulative.

1. The PBTH Rate and the Delta T&M Rates will escalate at a fixed rate of 1% on January 1, 2019.
2. The PBTH Rate and the Delta T&M Rates will escalate at a fixed rate of 1% on January 1, 2020.
3. Beginning on January 1, 2021, and on January 1 of each year during the Term thereafter, the PBTH Rate and the Delta T&M Rates will escalate as follows:
  - a. Delta will calculate the Inflation Index using the formula set forth below for the immediately preceding calendar year. The result will be rounded to the nearest Whole number.
  - b. If the result of the Inflation Index is equal to or less than 5%, then the PBTH Rate and the Delta T&M Rates will escalate at a fixed rate of 3%.
  - c. If the result of the Inflation Index is greater than 5%, then the PBTH Rate and the delta T&M Rates will escalate at a rate of 3% plus  $\frac{1}{2}$  the difference between the Inflation Index and 5%.

Example:

Assume the Inflation Index is 7%. The PBTH Rate and the Delta T&M Rates would escalate by 4%, calculated as follows:  $3\% + (0.5 * (7\% - 5\%))$ .

4. The Inflation Index formula is as follows:

$$\text{Inflation Index} = 0.55 * L + 0.45 * M$$

L = BLS issued index Aerospace Product and Parts Manufacturing NAICS 336400 (49-0000) as issued and compared to the prior year each January 1.

M = BLS issued index for PPI Commodity data for Transportation equipment-Aircraft and aircraft equipment, not seasonally adjusted. Series ID WPU 142.

For the avoidance of doubt Component Access and Exchange Flat Rates as well as Engineering Support Services Flat Rate are fixed and not subject to any escalations.



**Amendment No. 18**  
**to**  
**Inventory Support & Services Agreement**

This Amendment No. 18 (“Amendment”) to the Inventory Support & Services Agreement between Delta Air Lines, Inc (“Delta”) and MN Airlines, LLC (“MN Airlines”) dated both October 8, 2003 and October 27, 2003, (as amended, the “Agreement”), shall be effective as of May 15, 2019 (“Effective Date”).

WHEREAS, the parties have entered into the Agreement for the provision of certain maintenance services to MN Airlines; and

WHEREAS, the parties wish to amend the Agreement;

NOW, THEREFORE, in consideration of the mutual covenants hereinafter set forth and other good and valuable consideration, the receipt and sufficiency of which are hereby acknowledged, the parties hereby agree to amend the Agreement as follows:

1. All capitalized terms used herein but not defined shall have the meaning ascribed to them in the Agreement.
2. Annex A1 is hereby deleted in its entirety and replaced with a new Annex A1, which is attached hereto as Attachment 1.
3. Except as amended by this Amendment, all other provisions of the Agreement shall remain in full force and effect.

IN WITNESS WHEREOF, the parties have caused this Amendment to be executed by their duly authorized representatives as of the Effective Date.

MN AIRLINES, LLC  
 dba Sun Country Airlines

DELTA AIR LINES, INC.

By: /s/ Craig Hirman  
 Name: Craig Hirman  
 Title: *Senior Director Aircraft  
 Maintenance & Engineering*

By: /s/ Sonny Stern  
 Name: Sonny Stern  
 Title: MD MRO Services

Attachment 1 to Amendment

ANNEX A1

Description of Aircraft

<u>Registration #</u>	<u>Serial Number</u>	<u>Date of Manufacture</u>	<u>Effective Date for Additional Aircraft</u>
N710SY	30241	Dec-2001	
N711SY	30245	Jan-2002	
N713SY	30635	Nov-2000	
N716SY	30629	Dec-2001	
N801SY	30332	Feb-2001	
N804SY	30689	Aug-2001	
N805SY	30032	Nov-2001	
N808SY	33021	Mar-2005	
N809SY	30683	Mar-2005	
N813SY	28237	Feb-2001	
N814SY	30620	Oct-2001	
N815SY	30623	May-2002	
N816SY	30637	Mar-2001	
N817SY	30392	Apr-2001	
N819SY	34254	Mar-2006	
N820SY	39951	Nov-2014	
N821SY	39952	Dec-2014	
N822SY	33017	Oct-2004	
N823SY	33971	Dec-2001	
N824SY	33976	Jun-2005	
N825SY	34410	April 2006	
N826SY	34411	May 2006	
N827SY	34412	May 2006	
N828SY	34413	June 2006	
N829SY	34414	June 2006	
N830SY	28249	May 2002	
N831SY	30706	August 2001	
N832SY	40243	March 2011	May 17, 2019
N833SY	40244	April 2011	May 23, 2019
N834SY	40245	May 2011	June 23, 2019

In the event MN Airlines adds an additional aircraft to the fleet of Aircraft, that is reasonably determined by Delta to cause a material increase to Delta's cost to provide the Services (as measured on a per Aircraft basis), Delta reserves the right to adjust the PBTH Rate for that particular additional aircraft upon thirty (30) days' advance written notice. During such thirty (30) day notice period, upon request from MN Airlines, the parties shall negotiate in good faith to determine an alternative way of compensating Delta for the increase in cost caused by the particular additional Aircraft (such as a one-time payment from MN Airlines), provided that if mutual agreement on such alternative is not reached by the parties, the increased rate shall go into effect as one of the end of such thirty (30) day period for that particular aircraft.



## ISDA®

International Swaps and Derivatives Association, Inc.

## 2002 MASTER AGREEMENT

dated as of May 1, 2019

J. ARON &amp; COMPANY LLC

MN AIRLINES, LLC

and

have entered and/or anticipate entering into one or more transactions (each a “Transaction”) that are or will be governed by this 2002 Master Agreement, which includes the schedule (the “Schedule”), and the documents and other confirming evidence (each a “Confirmation”) exchanged between the parties or otherwise effective for the purpose of confirming or evidencing those Transactions. This 2002 Master Agreement and the Schedule are together referred to as this “Master Agreement”.

Accordingly, the parties agree as follows:—

**1. Interpretation**

(a) **Definitions.** The terms defined in Section 14 and elsewhere in this Master Agreement will have the meanings therein specified for the purpose of this Master Agreement.

(b) **Inconsistency.** In the event of any inconsistency between the provisions of the Schedule and the other provisions of this Master Agreement, the Schedule will prevail. In the event of any inconsistency between the provisions of any Confirmation and this Master Agreement, such Confirmation will prevail for the purpose of the relevant Transaction.

(c) **Single Agreement.** All Transactions are entered into in reliance on the fact that this Master Agreement and all Confirmations form a single agreement between the parties (collectively referred to as this “Agreement”), and the parties would not otherwise enter into any Transactions.

**2. Obligations****(a) General Conditions.**

(i) Each party will make each payment or delivery specified in each Confirmation to be made by it, subject to the other provisions of this Agreement.

(ii) Payments under this Agreement will be made on the due date for value on that date in the place of the account specified in the relevant Confirmation or otherwise pursuant to this Agreement, in freely transferable funds and in the manner customary for payments in the required currency. Where settlement is by delivery (that is, other than by payment), such delivery will be made for receipt on the due date in the manner customary for the relevant obligation unless otherwise specified in the relevant Confirmation or elsewhere in this Agreement.

(iii) Each obligation of each party under Section 2(a)(i) is subject to (1) the condition precedent that no Event of Default or Potential Event of Default with respect to the other party has occurred and is continuing, (2) the condition precedent that no Early Termination Date in respect of the relevant Transaction has occurred or been effectively designated and (3) each other condition specified in this Agreement to be a condition precedent for the purpose of this Section 2(a)(iii).

(b) **Change of Account.** Either party may change its account for receiving a payment or delivery by giving notice to the other party at least five Local Business Days prior to the Scheduled Settlement Date for the payment or delivery to which such change applies unless such other party gives timely notice of a reasonable objection to such change.

(c) **Netting of Payments.** If on any date amounts would otherwise be payable:—

- (i) in the same currency; and
- (ii) in respect of the same Transaction,

by each party to the other, then, on such date, each party's obligation to make payment of any such amount will be automatically satisfied and discharged and, if the aggregate amount that would otherwise have been payable by one party exceeds the aggregate amount that would otherwise have been payable by the other party, replaced by an obligation upon the party by which the larger aggregate amount would have been payable to pay to the other party the excess of the larger aggregate amount over the smaller aggregate amount.

The parties may elect in respect of two or more Transactions that a net amount and payment obligation will be determined in respect of all amounts payable on the same date in the same currency in respect of those Transactions, regardless of whether such amounts are payable in respect of the same Transaction. The election may be made in the Schedule or any Confirmation by specifying that "Multiple Transaction Payment Netting" applies to the Transactions identified as being subject to the election (in which case clause (ii) above will not apply to such Transactions). If Multiple Transaction Payment Netting is applicable to Transactions, it will apply to those Transactions with effect from the starting date specified in the Schedule or such Confirmation, or, if a starting date is not specified in the Schedule or such Confirmation, the starting date otherwise agreed by the parties in writing. This election may be made separately for different groups of Transactions and will apply separately to each pairing of Offices through which the parties make and receive payments or deliveries.

(d) **Deduction or Withholding for Tax.**

(i) **Gross-Up.** All payments under this Agreement will be made without any deduction or withholding for or on account of any Tax unless such deduction or withholding is required by any applicable law, as modified by the practice of any relevant governmental revenue authority, then in effect. If a party is so required to deduct or withhold, then that party ("X") will—

- (1) promptly notify the other party ("Y") of such requirement;
- (2) pay to the relevant authorities the full amount required to be deducted or withheld (including the full amount required to be deducted or withheld from any additional amount paid by X to Y under this Section 2(d)) promptly upon the earlier of determining that such deduction or withholding is required or receiving notice that such amount has been assessed against Y;
- (3) promptly forward to Y an official receipt (or a certified copy), or other documentation reasonably acceptable to Y, evidencing such payment to such authorities; and

(4) if such Tax is an Indemnifiable Tax, pay to Y, in addition to the payment to which Y is otherwise entitled under this Agreement, such additional amount as is necessary to ensure that the net amount actually received by Y (free and clear of Indemnifiable Taxes, whether assessed against X or Y) will equal the full amount Y would have received had no such deduction or withholding been required. However, X will not be required to pay any additional amount to Y to the extent that it would not be required to be paid but for:—

(A) the failure by Y to comply with or perform any agreement contained in Section 4(a)(i), 4(a)(iii) or 4(d); or

(B) the failure of a representation made by Y pursuant to Section 3(f) to be accurate and true unless such failure would not have occurred but for (I) any action taken by a taxing authority, or brought in a court of competent jurisdiction, after a Transaction is entered into (regardless of whether such action is taken or brought with respect to a party to this Agreement) or (II) a Change in Tax Law.

(ii) **Liability.** If:—

(1) X is required by any applicable law, as modified by the practice of any relevant governmental revenue authority, to make any deduction or withholding in respect of which X would not be required to pay an additional amount to Y under Section 2(d)(i)(4);

(2) X does not so deduct or withhold; and

(3) a liability resulting from such Tax is assessed directly against X,

then, except to the extent Y has satisfied or then satisfies the liability resulting from such Tax, Y will promptly pay to X the amount of such liability (including any related liability for interest, but including any related liability for penalties only if Y has failed to comply with or perform any agreement contained in Section 4(a)(i), 4(a)(iii) or 4(d)).

### 3. Representations

Each party makes the representations contained in Sections 3(a), 3(b), 3(c), 3(d), 3(e) and 3(f) and, if specified in the Schedule as applying, 3(g) to the other party (which representations will be deemed to be repeated by each party on each date on which a Transaction is entered into and, in the case of the representations in Section 3(f), at all times until the termination of this Agreement). If any “Additional Representation” is specified in the Schedule or any Confirmation as applying, the party or parties specified for such Additional Representation will make and, if applicable, be deemed to repeat such Additional Representation at the time or times specified for such Additional Representation.

(a) **Basic Representations.**

(i) **Status.** It is duly organised and validly existing under the laws of the jurisdiction of its organization or incorporation and, if relevant under such laws, in good standing;

(ii) **Powers.** It has the power to execute this Agreement and any other documentation relating to this Agreement to which it is a party, to deliver this Agreement and any other documentation relating to this Agreement that it is required by this Agreement to deliver and to perform its obligations under this Agreement and any obligations it has under any Credit Support Document to which it is a party and has taken all necessary action to authorize such execution, delivery and performance;

- (iii) **No Violation or Conflict.** Such execution, delivery and performance do not violate or conflict with any law applicable to it, any provision of its constitutional documents, any order or judgment of any court or other agency of government applicable to it or any of its assets or any contractual restriction binding on or affecting it or any of its assets;
- (iv) **Consents.** All governmental and other consents that are required to have been obtained by it with respect to this Agreement or any Credit Support Document to which it is a party have been obtained and are in full force and effect and all conditions of any such consents have been complied with; and
- (v) **Obligations Binding.** Its obligations under this Agreement and any Credit Support Document to which it is a party constitute its legal, valid and binding obligations, enforceable in accordance with their respective terms (subject to applicable bankruptcy, reorganization, insolvency, moratorium or similar laws affecting creditors' rights generally and subject, as to enforceability, to equitable principles of general application (regardless of whether enforcement is sought in a proceeding in equity or at law)).
- (b) **Absence of Certain Events.** No Event of Default or Potential Event of Default or, to its knowledge, Termination Event with respect to it has occurred and is continuing and no such event or circumstance would occur as a result of its entering into or performing its obligations under this Agreement or any Credit Support Document to which it is a party.
- (c) **Absence of Litigation.** There is not pending or, to its knowledge, threatened against it, any of its Credit Support Providers or any of its applicable Specified Entities any action, suit or proceeding at law or in equity or before any court, tribunal, governmental body, agency or official or any arbitrator that is likely to affect the legality, validity or enforceability against it of this Agreement or any Credit Support Document to which it is a party or its ability to perform its obligations under this Agreement or such Credit Support Document.
- (d) **Accuracy of Specified Information.** All applicable information that is furnished in writing by or on behalf of it to the other party and is identified for the purpose of this Section 3(d) in the Schedule is, as of the date of the information, true, accurate and complete in every material respect.
- (e) **Payer Tax Representation.** Each representation specified in the Schedule as being made by it for the purpose of this Section 3(e) is accurate and true.
- (f) **Payee Tax Representations.** Each representation specified in the Schedule as being made by it for the purpose of this Section 3(f) is accurate and true.
- (g) **No Agency.** It is entering into this Agreement, including each Transaction, as principal and not as agent of any person or entity.

#### 4. Agreements

Each party agrees with the other that, so long as either party has or may have any obligation under this Agreement or under any Credit Support Document to which it is a party:—

(a) **Furnish Specified Information.** It will deliver to the other party or, in certain cases under clause (iii) below, to such government or taxing authority as the other party reasonably directs:—

- (i) any forms, documents or certificates relating to taxation specified in the Schedule or any Confirmation;
- (ii) any other documents specified in the Schedule or any Confirmation; and

(iii) upon reasonable demand by such other party, any form or document that may be required or reasonably requested in writing in order to allow such other party or its Credit Support Provider to make a payment under this Agreement or any applicable Credit Support Document without any deduction or withholding for or on account of any Tax or with such deduction or withholding at a reduced rate (so long as the completion, execution or submission of such form or document would not materially prejudice the legal or commercial position of the party in receipt of such demand), with any such form or document to be accurate and completed in a manner reasonably satisfactory to such other party and to be executed and to be delivered with any reasonably required certification,

in each case by the date specified in the Schedule or such Confirmation or, if none is specified, as soon as reasonably practicable.

(b) **Maintain Authorisations.** It will use all reasonable efforts to maintain in full force and effect all consents of any governmental or other authority that are required to be obtained by it with respect to this Agreement or any Credit Support Document to which it is a party and will use all reasonable efforts to obtain any that may become necessary in the future.

(c) **Comply With Laws.** It will comply in all material respects with all applicable laws and orders to which it may be subject if failure so to comply would materially impair its ability to perform its obligations under this Agreement or any Credit Support Document to which it is a party.

(d) **Tax Agreement.** It will give notice of any failure of a representation made by it under Section 3(f) to be accurate and true promptly upon learning of such failure.

(e) **Payment of Stamp Tax.** Subject to Section 11, it will pay any Stamp Tax levied or imposed upon it or in respect of its execution or performance of this Agreement by a jurisdiction in which it is incorporated, organised, managed and controlled or considered to have its seat, or where an Office through which it is acting for the purpose of this Agreement is located (“Stamp Tax Jurisdiction”), and will indemnify the other party against any Stamp Tax levied or imposed upon the other party or in respect of the other party’s execution or performance of this Agreement by any such Stamp Tax Jurisdiction which is not also a Stamp Tax Jurisdiction with respect to the other party.

## 5. Events of Default and Termination Events

(a) **Events of Default.** The occurrence at any time with respect to a party or, if applicable, any Credit Support Provider of such party or any Specified Entity of such party of any of the following events constitutes (subject to Sections 5(c) and 6(e)(iv)) an event of default (an “Event of Default”) with respect to such party:—

(i) **Failure to Pay or Deliver.** Failure by the party to make, when due, any payment under this Agreement or delivery under Section 2(a)(i) or 9(h)(i)(2) or (4) required to be made by it if such failure is not remedied on or before the first Local Business Day in the case of any such payment or the first Local Delivery Day in the case of any such delivery after, in each case, notice of such failure is given to the party;

(ii) **Breach of Agreement; Repudiation of Agreement.**

(1) Failure by the party to comply with or perform any agreement or obligation (other than an obligation to make any payment under this Agreement or delivery under Section 2(a)(i) or 9(h)(i)(2) or (4) or to give notice of a Termination Event or any agreement or obligation under Section 4(a)(i), 4(a)(iii) or 4(d)) to be complied with or performed by the party in accordance with this Agreement if such failure is not remedied within 30 days after notice of such failure is given to the party; or

(2) the party disaffirms, disclaims, repudiates or rejects, in whole or in part, or challenges the validity of, this Master Agreement, any Confirmation executed and delivered by that party or any Transaction evidenced by such a Confirmation (or such action is taken by any person or entity appointed or empowered to operate it or act on its behalf);

(iii) **Credit Support Default.**

(1) Failure by the party or any Credit Support Provider of such party to comply with or perform any agreement or obligation to be complied with or performed by it in accordance with any Credit Support Document if such failure is continuing after any applicable grace period has elapsed;

(2) the expiration or termination of such Credit Support Document or the failing or ceasing of such Credit Support Document, or any security interest granted by such party or such Credit Support Provider to the other party pursuant to any such Credit Support Document, to be in full force and effect for the purpose of this Agreement (in each case other than in accordance with its terms) prior to the satisfaction of all obligations of such party under each Transaction to which such Credit Support Document relates without the written consent of the other party; or

(3) the party or such Credit Support Provider disaffirms, disclaims, repudiates or rejects, in whole or in part, or challenges the validity of, such Credit Support Document (or such action is taken by any person or entity appointed or empowered to operate it or act on its behalf);

(iv) **Misrepresentation.** A representation (other than a representation under Section 3(e) or 3(f)) made or repeated or deemed to have been made or repeated by the party or any Credit Support Provider of such party in this Agreement or any Credit Support Document proves to have been incorrect or misleading in any material respect when made or repeated or deemed to have been made or repeated;

(v) **Default Under Specified Transaction.** The party, any Credit Support Provider of such party or any applicable Specified Entity of such party:—

(1) defaults (other than by failing to make a delivery) under a Specified Transaction or any credit support arrangement relating to a Specified Transaction and, after giving effect to any applicable notice requirement or grace period, such default results in a liquidation of, an acceleration of obligations under, or an early termination of, that Specified Transaction;

(2) defaults, after giving effect to any applicable notice requirement or grace period, in making any payment due on the last payment or exchange date of, or any payment on early termination of, a Specified Transaction (or, if there is no applicable notice requirement or grace period, such default continues for at least one Local Business Day);

(3) defaults in making any delivery due under (including any delivery due on the last delivery or exchange date of) a Specified Transaction or any credit support arrangement relating to a Specified Transaction and, after giving effect to any applicable notice requirement or grace period, such default results in a liquidation of, an acceleration of obligations under, or an early termination of, all transactions outstanding under the documentation applicable to that Specified Transaction; or

(4) disaffirms, disclaims, repudiates or rejects, in whole or in part, or challenges the validity of, a Specified Transaction or any credit support arrangement relating to a Specified Transaction that is, in either case, confirmed or evidenced by a document or other confirming evidence executed and delivered by that party, Credit Support Provider or Specified Entity (or such action is taken by any person or entity appointed or empowered to operate it or act on its behalf);

(vi) **Cross-Default.** If “Cross-Default” is specified in the Schedule as applying to the party, the occurrence or existence of:—

(1) a default, event of default or other similar condition or event (however described ) in respect of such party, any Credit Support Provider of such party or any applicable Specified Entity of such party under one or more agreements or instruments relating to Specified Indebtedness of any of them (individually or collectively) where the aggregate principal amount of such agreements or instruments, either alone or together with the amount, if any, referred to in clause (2) below, is not less than the applicable Threshold Amount (as specified in the Schedule) which has resulted in such Specified Indebtedness becoming, or becoming capable at such time of being declared, due and payable under such agreements or instruments before it would otherwise have been due and payable; or

(2) a default by such party, such Credit Support Provider or such Specified Entity (individually or collectively) in making one or more payments under such agreements or instruments on the due date for payment (after giving effect to any applicable notice requirement or grace period) in an aggregate amount, either alone or together with the amount, if any, referred to in clause (1) above, of not less than the applicable Threshold Amount;

(vii) **Bankruptcy.** The party, any Credit Support Provider of such party or any applicable Specified Entity of such party:—

(1) is dissolved (other than pursuant to a consolidation, amalgamation or merger); (2) becomes insolvent or is unable to pay its debts or fails or admits in writing its inability generally to pay its debts as they become due; (3) makes a general assignment, arrangement or composition with or for the benefit of its creditors; (4)(A) institutes or has instituted against it, by a regulator, supervisor or any similar official with primary insolvency, rehabilitative or regulatory jurisdiction over it in the jurisdiction of its incorporation or organization or the jurisdiction of its head or home office, a proceeding seeking a judgment of insolvency or bankruptcy or any other relief under any bankruptcy or insolvency law or other similar law affecting creditors’ rights, or a petition is presented for its winding-up or liquidation by it or such regulator, supervisor or similar official, or (B) has instituted against it a proceeding seeking a judgment of insolvency or bankruptcy or any other relief under any bankruptcy or insolvency law or other similar law affecting creditors’ rights, or a petition is presented for its winding-up or liquidation, and such proceeding or petition is instituted or presented by a person or entity not described in clause (A) above and either (I) results in a judgment of insolvency or bankruptcy or the entry of an order for relief or the making of an order for its winding- up or liquidation or (II) is not dismissed, discharged, stayed or restrained in each case within 15 days of the institution or presentation thereof; (5) has a resolution passed for its winding-up, official management or liquidation (other than pursuant to a consolidation, amalgamation or merger); (6) seeks or becomes subject to the appointment of an administrator, provisional liquidator, conservator, receiver, trustee, custodian or other similar official for it or for all or substantially all its assets; (7) has a secured party take possession of all or substantially all its assets or has a distress, execution, attachment, sequestration or other legal process levied, enforced or sued on or against all or substantially all its assets and such secured party maintains possession, or any such process is not dismissed, discharged, stayed or restrained, in each case within 15 days thereafter; (8) causes or is subject to any event with respect to it which, under the applicable laws of any jurisdiction, has an analogous effect to any of the events specified in clauses (1) to (7) above (inclusive); or (9) takes any action in furtherance of, or indicating its consent to, approval of, or acquiescence in, any of the foregoing acts; or

(viii) **Merger Without Assumption.** The party or any Credit Support Provider of such party consolidates or amalgamates with, or merges with or into, or transfers all or substantially all its assets to, or reorganizes, reincorporates or reconstitutes into or as, another entity and, at the time of such consolidation, amalgamation, merger, transfer, reorganization, reincorporation or reconstitution:—

- (1) the resulting, surviving or transferee entity fails to assume all the obligations of such party or such Credit Support Provider under this Agreement or any Credit Support Document to which it or its predecessor was a party; or
- (2) the benefits of any Credit Support Document fail to extend (without the consent of the other party) to the performance by such resulting, surviving or transferee entity of its obligations under this Agreement.

(b) **Termination Events.** The occurrence at any time with respect to a party or, if applicable, any Credit Support Provider of such party or any Specified Entity of such party of any event specified below constitutes (subject to Section 5(c)) an Illegality if the event is specified in clause (i) below, a Force Majeure Event if the event is specified in clause (ii) below, a Tax Event if the event is specified in clause (iii) below, a Tax Event Upon Merger if the event is specified in clause (iv) below, and, if specified to be applicable, a Credit Event Upon Merger if the event is specified pursuant to clause (v) below or an Additional Termination Event if the event is specified pursuant to clause (vi) below:—

(i) **Illegality.** After giving effect to any applicable provision, disruption fallback or remedy specified in, or pursuant to, the relevant Confirmation or elsewhere in this Agreement, due to an event or circumstance (other than any action taken by a party or, if applicable, any Credit Support Provider of such party) occurring after a Transaction is entered into, it becomes unlawful under any applicable law (including without limitation the laws of any country in which payment, delivery or compliance is required by either party or any Credit Support Provider, as the case may be), on any day, or it would be unlawful if the relevant payment, delivery or compliance were required on that day (in each case, other than as a result of a breach by the party of Section 4(b)):—

- (1) for the Office through which such party (which will be the Affected Party) makes and receives payments or deliveries with respect to such Transaction to perform any absolute or contingent obligation to make a payment or delivery in respect of such Transaction, to receive a payment or delivery in respect of such Transaction or to comply with any other material provision of this Agreement relating to such Transaction; or
- (2) for such party or any Credit Support Provider of such party (which will be the Affected Party) to perform any absolute or contingent obligation to make a payment or delivery which such party or Credit Support Provider has under any Credit Support Document relating to such Transaction, to receive a payment or delivery under such Credit Support Document or to comply with any other material provision of such Credit Support Document;

(ii) **Force Majeure Event.** After giving effect to any applicable provision, disruption fallback or remedy specified in, or pursuant to, the relevant Confirmation or elsewhere in this Agreement, by reason of force majeure or act of state occurring after a Transaction is entered into, on any day:—

- (1) the Office through which such party (which will be the Affected Party) makes and receives payments or deliveries with respect to such Transaction is prevented from performing any absolute or contingent obligation to make a payment or delivery in respect of such Transaction, from receiving a payment or delivery in respect of such Transaction or from complying with any other material provision of this Agreement relating to such Transaction (or would be so prevented if such payment, delivery or compliance were required on that day), or it becomes impossible or impracticable for such Office so to perform, receive or comply (or it would be impossible or impracticable for such Office so to perform, receive or comply if such payment, delivery or compliance were required on that day); or



(2) such party or any Credit Support Provider of such party (which will be the Affected Party) is prevented from performing any absolute or contingent obligation to make a payment or delivery which such party or Credit Support Provider has under any Credit Support Document relating to such Transaction, from receiving a payment or delivery under such Credit Support Document or from complying with any other material provision of such Credit Support Document (or would be so prevented if such payment, delivery or compliance were required on that day), or it becomes impossible or impracticable for such party or Credit Support Provider so to perform, receive or comply (or it would be impossible or impracticable for such party or Credit Support Provider so to perform, receive or comply if such payment, delivery or compliance were required on that day),

so long as the force majeure or act of state is beyond the control of such Office, such party or such Credit Support Provider, as appropriate, and such Office, party or Credit Support Provider could not, after using all reasonable efforts (which will not require such party or Credit Support Provider to incur a loss, other than immaterial, incidental expenses), overcome such prevention, impossibility or impracticability;

(iii) **Tax Event.** Due to (1) any action taken by a taxing authority, or brought in a court of competent jurisdiction, after a Transaction is entered into (regardless of whether such action is taken or brought with respect to a party to this Agreement) or (2) a Change in Tax Law, the party (which will be the Affected Party) will, or there is a substantial likelihood that it will, on the next succeeding Scheduled Settlement Date (A) be required to pay to the other party an additional amount in respect of an Indemnifiable Tax under Section 2(d)(i)(4) (except in respect of interest under Section 9(h)) or (B) receive a payment from which an amount is required to be deducted or withheld for or on account of a Tax (except in respect of interest under Section 9(h)) and no additional amount is required to be paid in respect of such Tax under Section 2(d)(i)(4) (other than by reason of Section 2(d)(i)(4)(A) or (B));

(iv) **Tax Event Upon Merger.** The party (the “Burdened Party”) on the next succeeding Scheduled Settlement Date will either (1) be required to pay an additional amount in respect of an Indemnifiable Tax under Section 2(d)(i)(4) (except in respect of interest under Section 9(h)) or (2) receive a payment from which an amount has been deducted or withheld for or on account of any Tax in respect of which the other party is not required to pay an additional amount (other than by reason of Section 2(d)(i)(4)(A) or (B)), in either case as a result of a party consolidating or amalgamating with, or merging with or into, or transferring all or substantially all its assets (or any substantial part of the assets comprising the business conducted by it as of the date of this Master Agreement) to, or reorganizing, reincorporating or reconstituting into or as, another entity (which will be the Affected Party) where such action does not constitute a Merger Without Assumption;

(v) **Credit Event Upon Merger.** If “Credit Event Upon Merger” is specified in the Schedule as applying to the party, a Designated Event (as defined below) occurs with respect to such party, any Credit Support Provider of such party or any applicable Specified Entity of such party (in each case, “X”) and such Designated Event does not constitute a Merger Without Assumption, and the creditworthiness of X or, if applicable, the successor, surviving or transferee entity of X, after taking into account any applicable Credit Support Document, is materially weaker immediately after the occurrence of such Designated Event than that of X immediately prior to the occurrence of such Designated Event (and, in any such event, such party or its successor, surviving or transferee entity, as appropriate, will be the Affected Party). A “Designated Event” with respect to X means that:—

(1) X consolidates or amalgamates with, or merges with or into, or transfers all or substantially all its assets (or any substantial part of the assets comprising the business conducted by X as of the date of this Master Agreement) to, or reorganizes, reincorporates or reconstitutes into or as, another entity;

(2) any person, related group of persons or entity acquires directly or indirectly the beneficial ownership of (A) equity securities having the power to elect a majority of the board of directors (or its equivalent) of X or (B) any other ownership interest enabling it to exercise control of X; or

(3) X effects any substantial change in its capital structure by means of the issuance, incurrence or guarantee of debt or the issuance of (A) preferred stock or other securities convertible into or exchangeable for debt or preferred stock or (B) in the case of entities other than corporations, any other form of ownership interest; or

(vi) **Additional Termination Event.** If any “Additional Termination Event” is specified in the Schedule or any Confirmation as applying, the occurrence of such event (and, in such event, the Affected Party or Affected Parties will be as specified for such Additional Termination Event in the Schedule or such Confirmation).

**(c) Hierarchy of Events.**

(i) An event or circumstance that constitutes or gives rise to an Illegality or a Force Majeure Event will not, for so long as that is the case, also constitute or give rise to an Event of Default under Section 5(a)(i), 5(a)(ii)(1) or 5(a)(iii)(1) insofar as such event or circumstance relates to the failure to make any payment or delivery or a failure to comply with any other material provision of this Agreement or a Credit Support Document, as the case may be.

(ii) Except in circumstances contemplated by clause (i) above, if an event or circumstance which would otherwise constitute or give rise to an Illegality or a Force Majeure Event also constitutes an Event of Default or any other Termination Event, it will be treated as an Event of Default or such other Termination Event, as the case may be, and will not constitute or give rise to an Illegality or a Force Majeure Event.

(iii) If an event or circumstance which would otherwise constitute or give rise to a Force Majeure Event also constitutes an Illegality, it will be treated as an Illegality, except as described in clause (ii) above, and not a Force Majeure Event.

**(d) Deferral of Payments and Deliveries During Waiting Period.** If an Illegality or a Force Majeure Event has occurred and is continuing with respect to a Transaction, each payment or delivery which would otherwise be required to be made under that Transaction will be deferred to, and will not be due until:—

(i) the first Local Business Day or, in the case of a delivery, the first Local Delivery Day (or the first day that would have been a Local Business Day or Local Delivery Day, as appropriate, but for the occurrence of the event or circumstance constituting or giving rise to that Illegality or Force Majeure Event) following the end of any applicable Waiting Period in respect of that Illegality or Force Majeure Event, as the case may be; or

(ii) if earlier, the date on which the event or circumstance constituting or giving rise to that Illegality or Force Majeure Event ceases to exist or, if such date is not a Local Business Day or, in the case of a delivery, a Local Delivery Day, the first following day that is a Local Business Day or Local Delivery Day, as appropriate.

**(e) Inability of Head or Home Office to Perform Obligations of Branch.** If (i) an Illegality or a Force Majeure Event occurs under Section 5(b)(i)(1) or 5(b)(ii)(1) and the relevant Office is not the Affected Party’s head or home office, (ii) Section 10(a) applies, (iii) the other party seeks performance of the relevant obligation or

compliance with the relevant provision by the Affected Party's head or home office and (iv) the Affected Party's head or home office fails so to perform or comply due to the occurrence of an event or circumstance which would, if that head or home office were the Office through which the Affected Party makes and receives payments and deliveries with respect to the relevant Transaction, constitute or give rise to an Illegality or a Force Majeure Event, and such failure would otherwise constitute an Event of Default under Section 5(a)(i) or 5(a)(iii)(1) with respect to such party, then, for so long as the relevant event or circumstance continues to exist with respect to both the Office referred to in Section 5(b)(i)(1) or 5(b)(ii)(1), as the case may be, and the Affected Party's head or home office, such failure will not constitute an Event of Default under Section 5(a)(i) or 5(a)(iii)(1).

## **6. Early Termination; Close-Out Netting**

(a) **Right to Terminate Following Event of Default.** If at any time an Event of Default with respect to a party (the "Defaulting Party") has occurred and is then continuing, the other party (the "Non-defaulting Party") may, by not more than 20 days notice to the Defaulting Party specifying the relevant Event of Default, designate a day not earlier than the day such notice is effective as an Early Termination Date in respect of all outstanding Transactions. If, however, "Automatic Early Termination" is specified in the Schedule as applying to a party, then an Early Termination Date in respect of all outstanding Transactions will occur immediately upon the occurrence with respect to such party of an Event of Default specified in Section 5(a)(vii)(1), (3), (5), (6) or, to the extent analogous thereto, (8), and as of the time immediately preceding the institution of the relevant proceeding or the presentation of the relevant petition upon the occurrence with respect to such party of an Event of Default specified in Section 5(a)(vii)(4) or, to the extent analogous thereto, (8).

(b) **Right to Terminate Following Termination Event.**

(i) **Notice.** If a Termination Event other than a Force Majeure Event occurs, an Affected Party will, promptly upon becoming aware of it, notify the other party, specifying the nature of that Termination Event and each Affected Transaction, and will also give the other party such other information about that Termination Event as the other party may reasonably require. If a Force Majeure Event occurs, each party will, promptly upon becoming aware of it, use all reasonable efforts to notify the other party, specifying the nature of that Force Majeure Event, and will also give the other party such other information about that Force Majeure Event as the other party may reasonably require.

(ii) **Transfer to Avoid Termination Event.** If a Tax Event occurs and there is only one Affected Party, or if a Tax Event Upon Merger occurs and the Burdened Party is the Affected Party, the Affected Party will, as a condition to its right to designate an Early Termination Date under Section 6(b)(iv), use all reasonable efforts (which will not require such party to incur a loss, other than immaterial, incidental expenses) to transfer within 20 days after it gives notice under Section 6(b)(i) all its rights and obligations under this Agreement in respect of the Affected Transactions to another of its Offices or Affiliates so that such Termination Event ceases to exist.

If the Affected Party is not able to make such a transfer it will give notice to the other party to that effect within such 20 day period, whereupon the other party may effect such a transfer within 30 days after the notice is given under Section 6(b)(i).

Any such transfer by a party under this Section 6(b)(ii) will be subject to and conditional upon the prior written consent of the other party, which consent will not be withheld if such other party's policies in effect at such time would permit it to enter into transactions with the transferee on the terms proposed.

(iii) **Two Affected Parties.** If a Tax Event occurs and there are two Affected Parties, each party will use all reasonable efforts to reach agreement within 30 days after notice of such occurrence is given under Section 6(b)(i) to avoid that Termination Event.

(iv) **Right to Terminate.**

(1) If:—

(A) a transfer under Section 6(b)(ii) or an agreement under Section 6(b)(iii), as the case may be, has not been effected with respect to all Affected Transactions within 30 days after an Affected Party gives notice under Section 6(b)(i); or

(B) a Credit Event Upon Merger or an Additional Termination Event occurs, or a Tax Event Upon Merger occurs and the Burdened Party is not the Affected Party,

the Burdened Party in the case of a Tax Event Upon Merger, any Affected Party in the case of a Tax Event or an Additional Termination Event if there are two Affected Parties, or the Non-affected Party in the case of a Credit Event Upon Merger or an Additional Termination Event if there is only one Affected Party may, if the relevant Termination Event is then continuing, by not more than 20 days notice to the other party, designate a day not earlier than the day such notice is effective as an Early Termination Date in respect of all Affected Transactions.

(2) If at any time an Illegality or a Force Majeure Event has occurred and is then continuing and any applicable Waiting Period has expired:—

(A) Subject to clause (B) below, either party may, by not more than 20 days notice to the other party, designate (I) a day not earlier than the day on which such notice becomes effective as an Early Termination Date in respect of all Affected Transactions or (II) by specifying in that notice the Affected Transactions in respect of which it is designating the relevant day as an Early Termination Date, a day not earlier than two Local Business Days following the day on which such notice becomes effective as an Early Termination Date in respect of less than all Affected Transactions. Upon receipt of a notice designating an Early Termination Date in respect of less than all Affected Transactions, the other party may, by notice to the designating party, if such notice is effective on or before the day so designated, designate that same day as an Early Termination Date in respect of any or all other Affected Transactions.

(B) An Affected Party (if the Illegality or Force Majeure Event relates to performance by such party or any Credit Support Provider of such party of an obligation to make any payment or delivery under, or to compliance with any other material provision of, the relevant Credit Support Document) will only have the right to designate an Early Termination Date under Section 6(b)(iv)(2)(A) as a result of an Illegality under Section 5(b)(i)(2) or a Force Majeure Event under Section 5(b)(ii)(2) following the prior designation by the other party of an Early Termination Date, pursuant to Section 6(b)(iv)(2)(A), in respect of less than all Affected Transactions.

(c) **Effect of Designation.**

(i) If notice designating an Early Termination Date is given under Section 6(a) or 6(b), the Early Termination Date will occur on the date so designated, whether or not the relevant Event of Default or Termination Event is then continuing.

(ii) Upon the occurrence or effective designation of an Early Termination Date, no further payments or deliveries under Section 2(a)(i) or 9(h)(i) in respect of the Terminated Transactions will be required to be made, but without prejudice to the other provisions of this Agreement. The amount, if any, payable in respect of an Early Termination Date will be determined pursuant to Sections 6(e) and 9(h)(ii).

(d) **Calculations; Payment Date.**

(i) **Statement.** On or as soon as reasonably practicable following the occurrence of an Early Termination Date, each party will make the calculations on its part, if any, contemplated by Section 6(e) and will provide to the other party a statement (1) showing, in reasonable detail, such calculations (including any quotations, market data or information from internal sources used in making such calculations), (2) specifying (except where there are two Affected Parties) any Early Termination Amount payable and (3) giving details of the relevant account to which any amount payable to it is to be paid. In the absence of written confirmation from the source of a quotation or market data obtained in determining a Close-out Amount, the records of the party obtaining such quotation or market data will be conclusive evidence of the existence and accuracy of such quotation or market data.

(ii) **Payment Date.** An Early Termination Amount due in respect of any Early Termination Date will, together with any amount of interest payable pursuant to Section 9(h)(ii)(2), be payable (1) on the day on which notice of the amount payable is effective in the case of an Early Termination Date which is designated or occurs as a result of an Event of Default and (2) on the day which is two Local Business Days after the day on which notice of the amount payable is effective (or, if there are two Affected Parties, after the day on which the statement provided pursuant to clause (i) above by the second party to provide such a statement is effective) in the case of an Early Termination Date which is designated as a result of a Termination Event.

(e) **Payments on Early Termination.** If an Early Termination Date occurs, the amount, if any, payable in respect of that Early Termination Date (the “Early Termination Amount”) will be determined pursuant to this Section 6(e) and will be subject to Section 6(f).

(i) **Events of Default.** If the Early Termination Date results from an Event of Default, the Early Termination Amount will be an amount equal to (1) the sum of (A) the Termination Currency Equivalent of the Close-out Amount or Close-out Amounts (whether positive or negative) determined by the Non-defaulting Party for each Terminated Transaction or group of Terminated Transactions, as the case may be, and (B) the Termination Currency Equivalent of the Unpaid Amounts owing to the Non-defaulting Party less

(2) the Termination Currency Equivalent of the Unpaid Amounts owing to the Defaulting Party. If the Early Termination Amount is a positive number, the Defaulting Party will pay it to the Non-defaulting Party; if it is a negative number, the Non-defaulting Party will pay the absolute value of Early Termination Amount to the Defaulting Party.

(ii) **Termination Events.** If the Early Termination Date results from a Termination Event:—

(1) *One Affected Party.* Subject to clause (3) below, if there is one Affected Party, the Early Termination Amount will be determined in accordance with Section 6(e)(i), except that references to the Defaulting Party and to the Non-defaulting Party will be deemed to be references to the Affected Party and to the Non-affected Party, respectively.

(2) *Two Affected Parties.* Subject to clause (3) below, if there are two Affected Parties, each party will determine an amount equal to the Termination Currency Equivalent of the sum of the Close-out Amount or Close-out Amounts (whether positive or negative) for each Terminated Transaction or group of Terminated Transactions, as the case may be, and the Early Termination Amount will be an amount equal to (A) the sum of (I) one-half of the difference between the higher amount so determined (by party “X”) and lower amount so determined (by party “Y”) and (II) the Termination Currency Equivalent of the Unpaid Amounts owing to X less (B) the Termination Currency Equivalent of the Unpaid Amounts owing to Y. If the Early Termination Amount is a positive number, Y will pay it to X; if it is a negative number, X will pay the absolute value of the Early Termination Amount to Y.

(3) *Mid-Market Events*. If that Termination Event is an Illegality or a Force Majeure Event, then the Early Termination Amount will be determined in accordance with clause (1) or (2) above, as appropriate, except that, for the purpose of determining a Close-out Amount or Close-out Amounts, the Determining Party will:—

(A) if obtaining quotations from one or more third parties (or from any of the Determining Party's Affiliates), ask each third party or Affiliate (I) not to take account of the current creditworthiness of the Determining Party or any existing Credit Support Document and (II) to provide mid-market quotations; and

(B) in any other case, use mid-market values without regard to the creditworthiness of the Determining Party.

(iii) *Adjustment for Bankruptcy*. In circumstances where an Early Termination Date occurs because Automatic Early Termination applies in respect of a party, Early Termination Amount will be subject to such adjustments as are appropriate and permitted by applicable law to reflect any payments or deliveries made by one party to the other under this Agreement (and retained by such other party) during the period from the relevant Early Termination Date to the date for payment determined under Section 6(d)(ii).

(iv) *Adjustment for Illegality or Force Majeure Event*. The failure by a party or any Credit Support Provider of such party to pay, when due, any Early Termination Amount will not constitute an Event of Default under Section 5(a)(i) or 5(a)(iii)(1) if such failure is due to the occurrence of an event or circumstance which would, if it occurred with respect to payment, delivery or compliance related to a Transaction, constitute or give rise to an Illegality or a Force Majeure Event. Such amount will (1) accrue interest and otherwise be treated as an Unpaid Amount owing to the other party if subsequently an Early Termination Date results from an Event of Default, a Credit Event Upon Merger or an Additional Termination Event in respect of which all outstanding Transactions are Affected Transactions and (2) otherwise accrue interest in accordance with Section 9(h)(ii)(2).

(v) *Pre-Estimate*. The parties agree that an amount recoverable under this Section 6(e) is a reasonable pre-estimate of loss and not a penalty. Such amount is payable for the loss of bargain and the loss of protection against future risks, and, except as otherwise provided in this Agreement, neither party will be entitled to recover any additional damages as a consequence of the termination of the Terminated Transactions.

(f) *Set-Off*. Any Early Termination Amount payable to one party (the "Payee") by the other party (the "Payer"), in circumstances where there is a Defaulting Party or where there is one Affected Party in the case where either a Credit Event Upon Merger has occurred or any other Termination Event in respect of which all outstanding Transactions are Affected Transactions has occurred, will, at the option of the Non-defaulting Party or the Non-affected Party, as the case may be ("X") (and without prior notice to the Defaulting Party or the Affected Party, as the case may be), be reduced by its set-off against any other amounts ("Other Amounts") payable by the Payee to the Payer (whether or not arising under this Agreement, matured or contingent and irrespective of the currency, place of payment or place of booking of the obligation). To the extent that any Other Amounts are so set off, those Other Amounts will be discharged promptly and in all respects. X will give notice to the other party of any set-off effected under this Section 6(f).

For this purpose, either the Early Termination Amount or the Other Amounts (or the relevant portion of such amounts) may be converted by X into the currency in which the other is denominated at the rate of exchange at which such party would be able, in good faith and using commercially reasonable procedures, to purchase the relevant amount of such currency.

If an obligation is unascertained, X may in good faith estimate that obligation and set off in respect of the estimate, subject to the relevant party accounting to the other when the obligation is ascertained.

Nothing in this Section 6(f) will be effective to create a charge or other security interest. This Section 6(f) will be without prejudice and in addition to any right of set-off, offset, combination of accounts, lien, right of retention or withholding or similar right or requirement to which any party is at any time otherwise entitled or subject (whether by operation of law, contract or otherwise).

## 7. Transfer

Subject to Section 6(b)(ii) and to the extent permitted by applicable law, neither this Agreement nor any interest or obligation in or under this Agreement may be transferred (whether by way of security or otherwise) by either party without the prior written consent of the other party, except that:—

(a) a party may make such a transfer of this Agreement pursuant to a consolidation or amalgamation with, or merger with or into, or transfer of all or substantially all its assets to, another entity (but without prejudice to any other right or remedy under this Agreement); and

(b) a party may make such a transfer of all or any part of its interest in any Early Termination Amount payable to it by a Defaulting Party, together with any amounts payable on or with respect to that interest and any other rights associated with that interest pursuant to Sections 8, 9(h) and 11.

Any purported transfer that is not in compliance with this Section 7 will be void.

## 8. Contractual Currency

(a) **Payment in the Contractual Currency.** Each payment under this Agreement will be made in the relevant currency specified in this Agreement for that payment (the “Contractual Currency”). To the extent permitted by applicable law, any obligation to make payments under this Agreement in the Contractual Currency will not be discharged or satisfied by any tender in any currency other than the Contractual Currency, except to the extent such tender results in the actual receipt by the party to which payment is owed, acting in good faith and using commercially reasonable procedures in converting the currency so tendered into the Contractual Currency, of the full amount in the Contractual Currency of all amounts payable in respect of this Agreement. If for any reason the amount in the Contractual Currency so received falls short of the amount in the Contractual Currency payable in respect of this Agreement, the party required to make the payment will, to the extent permitted by applicable law, immediately pay such additional amount in the Contractual Currency as may be necessary to compensate for the shortfall. If for any reason the amount in the Contractual Currency so received exceeds the amount in the Contractual Currency payable in respect of this Agreement, the party receiving the payment will refund promptly the amount of such excess.

(b) **Judgments.** To the extent permitted by applicable law, if any judgment or order expressed in a currency other than the Contractual Currency is rendered (i) for the payment of any amount owing in respect of this Agreement, (ii) for the payment of any amount relating to any early termination in respect of this Agreement or (iii) in respect of a judgment or order of another court for the payment of any amount described in clause (i) or (ii) above, the party seeking recovery, after recovery in full of the aggregate amount to which such party is entitled pursuant to the judgment or order, will be entitled to receive immediately from the other party the amount of any shortfall of the Contractual Currency received by such party as a consequence of sums paid in such other currency and will refund promptly to the other party any excess of the Contractual Currency received by such party as a consequence of sums paid in such other currency if such shortfall or such excess arises or results from any variation between the rate of exchange at which the Contractual Currency is converted into the currency of the judgment or order for the purpose of such judgment or order and the rate of exchange at which such party is able, acting in good faith and using commercially reasonable procedures in converting the currency received into the Contractual Currency, to purchase the Contractual Currency with the amount of the currency of the judgment or order actually received by such party.

(c) **Separate Indemnities.** To the extent permitted by applicable law, the indemnities in this Section 8 constitute separate and independent obligations from the other obligations in this Agreement, will be enforceable as separate and independent causes of action, will apply notwithstanding any indulgence granted by the party to which any payment is owed and will not be affected by judgment being obtained or claim or proof being made for any other sums payable in respect of this Agreement.

(d) **Evidence of Loss.** For the purpose of this Section 8, it will be sufficient for a party to demonstrate that it would have suffered a loss had an actual exchange or purchase been made.

## 9. Miscellaneous

(a) **Entire Agreement.** This Agreement constitutes the entire agreement and understanding of the parties with respect to its subject matter. Each of the parties acknowledges that in entering into this Agreement it has not relied on any oral or written representation, warranty or other assurance (except as provided for or referred to in this Agreement) and waives all rights and remedies which might otherwise be available to it in respect thereof, except that nothing in this Agreement will limit or exclude any liability of a party for fraud.

(b) **Amendments.** An amendment, modification or waiver in respect of this Agreement will only be effective if in writing (including a writing evidenced by a facsimile transmission) and executed by each of the parties or confirmed by an exchange of telexes or by an exchange of electronic messages on an electronic messaging system.

(c) **Survival of Obligations.** Without prejudice to Sections 2(a)(iii) and 6(c)(ii), the obligations of the parties under this Agreement will survive the termination of any Transaction.

(d) **Remedies Cumulative.** Except as provided in this Agreement, the rights, powers, remedies and privileges provided in this Agreement are cumulative and not exclusive of any rights, powers, remedies and privileges provided by law.

(e) **Counterparts and Confirmations.**

(i) This Agreement (and each amendment, modification and waiver in respect of it) may be executed and delivered in counterparts (including by facsimile transmission and by electronic messaging system), each of which will be deemed an original.

(ii) The parties intend that they are legally bound by the terms of each Transaction from the moment they agree to those terms (whether orally or otherwise). A Confirmation will be entered into as soon as practicable and may be executed and delivered in counterparts (including by facsimile transmission) or be created by an exchange of telexes, by an exchange of electronic messages on an electronic messaging system or by an exchange of e-mails, which in each case will be sufficient for all purposes to evidence a binding supplement to this Agreement. The parties will specify therein or through another effective means that any such counterpart, telex, electronic message or e-mail constitutes a Confirmation.

(f) **No Waiver of Rights.** A failure or delay in exercising any right, power or privilege in respect of this Agreement will not be presumed to operate as a waiver, and a single or partial exercise of any right, power or privilege will not be presumed to preclude any subsequent or further exercise, of that right, power or privilege or the exercise of any other right, power or privilege

(g) **Headings.** The headings used in this Agreement are for convenience of reference only and are not to affect the construction of or to be taken into consideration in interpreting this Agreement.



(h) **Interest and Compensation.**

(i) **Prior to Early Termination.** Prior to the occurrence or effective designation of an Early Termination Date in respect of the relevant Transaction:—

(1) *Interest on Defaulted Payments.* If a party defaults in the performance of any payment obligation, it will, to the extent permitted by applicable law and subject to Section 6(c), pay interest (before as well as after judgment) on the overdue amount to the other party on demand in the same currency as the overdue amount, for the period from (and including) the original due date for payment to (but excluding) the date of actual payment (and excluding any period in respect of which interest or compensation in respect of the overdue amount is due pursuant to clause (3)(B) or (C) below), at the Default Rate.

(2) *Compensation for Defaulted Deliveries.* If a party defaults in the performance of any obligation required to be settled by delivery, it will on demand (A) compensate the other party to the extent provided for in the relevant Confirmation or elsewhere in this Agreement and (B) unless otherwise provided in the relevant Confirmation or elsewhere in this Agreement, to the extent permitted by applicable law and subject to Section 6(c), pay to the other party interest (before as well as after judgment) on an amount equal to the fair market value of that which was required to be delivered in the same currency as that amount, for the period from (and including) the originally scheduled date for delivery to (but excluding) the date of actual delivery (and excluding any period in respect of which interest or compensation in respect of that amount is due pursuant to clause (4) below), at the Default Rate. The fair market value of any obligation referred to above will be determined as of the originally scheduled date for delivery, in good faith and using commercially reasonable procedures, by the party that was entitled to take delivery.

(3) *Interest on Deferred Payments.* If:—

(A) a party does not pay any amount that, but for Section 2(a)(iii), would have been payable, it will, to the extent permitted by applicable law and subject to Section 6(c) and clauses (B) and (C) below, pay interest (before as well as after judgment) on that amount to the other party on demand (after such amount becomes payable) in the same currency as that amount, for the period from (and including) the date the amount would, but for Section 2(a)(iii), have been payable to (but excluding) the date the amount actually becomes payable, at the Applicable Deferral Rate;

(B) a payment is deferred pursuant to Section 5(d), the party which would otherwise have been required to make that payment will, to the extent permitted by applicable law, subject to Section 6(c) and for so long as no Event of Default or Potential Event of Default with respect to that party has occurred and is continuing, pay interest (before as well as after judgment) on the amount of the deferred payment to the other party on demand (after such amount becomes payable) in the same currency as the deferred payment, for the period from (and including) the date the amount would, but for Section 5(d), have been payable to (but excluding) the earlier of the date the payment is no longer deferred pursuant to Section 5(d) and the date during the deferral period upon which an Event of Default or Potential Event of Default with respect to that party occurs, at the Applicable Deferral Rate; or

(C) a party fails to make any payment due to the occurrence of an Illegality or a Force Majeure Event (after giving effect to any deferral period contemplated by clause (B) above), it will, to the extent permitted by applicable law, subject to Section 6(c) and for so long as the event or circumstance giving rise to that Illegality or Force Majeure Event

continues and no Event of Default or Potential Event of Default with respect to that party has occurred and is continuing, pay interest (before as well as after judgment) on the overdue amount to the other party on demand in the same currency as the overdue amount, for the period from (and including) the date the party fails to make the payment due to the occurrence of the relevant Illegality or Force Majeure Event (or, if later, the date the payment is no longer deferred pursuant to Section 5(d)) to (but excluding) the earlier of the date the event or circumstance giving rise to that Illegality or Force Majeure Event ceases to exist and the date during the period upon which an Event of Default or Potential Event of Default with respect to that party occurs (and excluding any period in respect of which interest or compensation in respect of the overdue amount is due pursuant to clause (B) above), at the Applicable Deferral Rate.

(4) *Compensation for Deferred Deliveries*. If:—

(A) a party does not perform any obligation that, but for Section 2(a)(iii), would have been required to be settled by delivery;

(B) a delivery is deferred pursuant to Section 5(d); or

(C) a party fails to make a delivery due to the occurrence of an Illegality or a Force Majeure Event at a time when any applicable Waiting Period has expired,

the party required (or that would otherwise have been required) to make the delivery will, to the extent permitted by applicable law and subject to Section 6(c), compensate and pay interest to the other party on demand (after, in the case of clauses (A) and (B) above, such delivery is required) if and to the extent provided for in the relevant Confirmation or elsewhere in this Agreement.

(ii) **Early Termination**. Upon the occurrence or effective designation of an Early Termination Date in respect of a Transaction:—

(1) *Unpaid Amounts*. For the purpose of determining an Unpaid Amount in respect of the relevant Transaction, and to the extent permitted by applicable law, interest will accrue on the amount of any payment obligation or the amount equal to the fair market value of any obligation required to be settled by delivery included in such determination in the same currency as that amount, for the period from (and including) the date the relevant obligation was (or would have been but for Section 2(a)(iii) or 5(d)) required to have been performed to (but excluding) the relevant Early Termination Date, at the Applicable Close-out Rate.

(2) *Interest on Early Termination Amounts*. If an Early Termination Amount is due in respect of such Early Termination Date, that amount will, to the extent permitted by applicable law, be paid together with interest (before as well as after judgment) on that amount in the Termination Currency, for the period from (and including) such Early Termination Date to (but excluding) the date the amount is paid, at the Applicable Close-out Rate.

(iii) **Interest Calculation**. Any interest pursuant to this Section 9(h) will be calculated on the basis of daily compounding and the actual number of days elapsed.

## 10. Offices; Multibranch Parties

(a) If Section 10(a) is specified in the Schedule as applying, each party that enters into a Transaction through an Office other than its head or home office represents to and agrees with the other party that, notwithstanding the place of booking or its jurisdiction of incorporation or organization, its obligations are the same in terms of recourse against it as if it had entered into the Transaction through its head or home office, except that a party will not have recourse to the head or home office of the other party in respect of any payment or delivery deferred pursuant to Section 5(d) for so long as the payment or delivery is so deferred. This representation and agreement will be deemed to be repeated by each party on each date on which the parties enter into a Transaction.

(b) If a party is specified as a Multibranch Party in the Schedule, such party may, subject to clause (c) below, enter into a Transaction through, book a Transaction in and make and receive payments and deliveries with respect to a Transaction through any Office listed in respect of that party in the Schedule (but not any other Office unless otherwise agreed by the parties in writing).

(c) The Office through which a party enters into a Transaction will be the Office specified for that party in the relevant Confirmation or as otherwise agreed by the parties in writing, and, if an Office for that party is not specified in the Confirmation or otherwise agreed by the parties in writing, its head or home office. Unless the parties otherwise agree in writing, the Office through which a party enters into a Transaction will also be the Office in which it books the Transaction and the Office through which it makes and receives payments and deliveries with respect to the Transaction. Subject to Section 6(b)(ii), neither party may change the Office in which it books the Transaction or the Office through which it makes and receives payments or deliveries with respect to a Transaction without the prior written consent of the other party.

## 11. Expenses

A Defaulting Party will on demand indemnify and hold harmless the other party for and against all reasonable out-of-pocket expenses, including legal fees, execution fees and Stamp Tax, incurred by such other party by reason of the enforcement and protection of its rights under this Agreement or any Credit Support Document to which the Defaulting Party is a party or by reason of the early termination of any Transaction, including, but not limited to, costs of collection.

## 12. Notices

(a) **Effectiveness.** Any notice or other communication in respect of this Agreement may be given in any manner described below (except that a notice or other communication under Section 5 or 6 may not be given by electronic messaging system or e-mail) to the address or number or in accordance with the electronic messaging system or e-mail details provided (see the Schedule) and will be deemed effective as indicated:—

- (i) if in writing and delivered in person or by courier, on the date it is delivered;
- (ii) if sent by telex, on the date the recipient's answerback is received;
- (iii) if sent by facsimile transmission, on the date it is received by a responsible employee of the recipient in legible form (it being agreed that the burden of proving receipt will be on the sender and will not be met by a transmission report generated by the sender's facsimile machine);
- (iv) if sent by certified or registered mail (airmail, if overseas) or the equivalent (return receipt requested), on the date it is delivered or its delivery is attempted;
- (v) if sent by electronic messaging system, on the date it is received; or
- (vi) if sent by e-mail, on the date it is delivered,

unless the date of that delivery (or attempted delivery) or that receipt, as applicable, is not a Local Business Day or that communication is delivered (or attempted) or received, as applicable, after the close of business on a Local Business Day, in which case that communication will be deemed given and effective on the first following day that is a Local Business Day.

(b) **Change of Details.** Either party may by notice to the other change the address, telex or facsimile number or electronic messaging system or e-mail details at which notices or other communications are to be given to it.

### 13. Governing Law and Jurisdiction

(a) **Governing Law.** This Agreement will be governed by and construed in accordance with the law specified in the Schedule.

(b) **Jurisdiction.** With respect to any suit, action or proceedings relating to any dispute arising out of or in connection with this Agreement (“Proceedings”), each party irrevocably:—

(i) submits:—

(1) if this Agreement is expressed to be governed by English law, to (A) the non-exclusive jurisdiction of the English courts if the Proceedings do not involve a Convention Court and (B) the exclusive jurisdiction of the English courts if the Proceedings do involve a Convention Court; or

(2) if this Agreement is expressed to be governed by the laws of the State of New York, to the non-exclusive jurisdiction of the courts of the State of New York and the United States District Court located in the Borough of Manhattan in New York City;

(ii) waives any objection which it may have at any time to the laying of venue of any Proceedings brought in any such court, waives any claim that such Proceedings have been brought in an inconvenient forum and further waives the right to object, with respect to such Proceedings, that such court does not have any jurisdiction over such party; and

(iii) agrees, to the extent permitted by applicable law, that the bringing of Proceedings in any one or more jurisdictions will not preclude the bringing of Proceedings in any other jurisdiction.

(c) **Service of Process.** Each party irrevocably appoints the Process Agent, if any, specified opposite its name in the Schedule to receive, for it and on its behalf, service of process in any Proceedings. If for any reason any party’s Process Agent is unable to act as such, such party will promptly notify the other party and within 30 days appoint a substitute process agent acceptable to the other party. The parties irrevocably consent to service of process given in the manner provided for notices in Section 12(a)(i), 12(a)(iii) or 12(a)(iv). Nothing in this Agreement will affect the right of either party to serve process in any other manner permitted by applicable law.

(d) **Waiver of Immunities.** Each party irrevocably waives, to the extent permitted by applicable law, with respect to itself and its revenues and assets (irrespective of their use or intended use), all immunity on the grounds of sovereignty or other similar grounds from (i) suit, (ii) jurisdiction of any court, (iii) relief by way of injunction or order for specific performance or recovery of property, (iv) attachment of its assets (whether before or after judgment) and (v) execution or enforcement of any judgment to which it or its revenues or assets might otherwise be entitled in any Proceedings in the courts of any jurisdiction and irrevocably agrees, to the extent permitted by applicable law, that it will not claim any such immunity in any Proceedings.

#### 14. Definitions

As used in this Agreement:—

**“Additional Representation”** has the meaning specified in Section 3. **“Additional Termination Event”** has the meaning specified in Section 5(b). **“Affected Party”** has the meaning specified in Section 5(b).

**“Affected Transactions”** means (a) with respect to any Termination Event consisting of an Illegality, Force Majeure Event, Tax Event or Tax Event Upon Merger, all Transactions affected by the occurrence of such Termination Event (which, in the case of an Illegality under Section 5(b)(i)(2) or a Force Majeure Event under Section 5(b)(ii)(2), means all Transactions unless the relevant Credit Support Document references only certain Transactions, in which case those Transactions and, if the relevant Credit Support Document constitutes a Confirmation for a Transaction, that Transaction) and (b) with respect to any other Termination Event, all Transactions.

**“Affiliate”** means, subject to the Schedule, in relation to any person, any entity controlled, directly or indirectly, by the person, any entity that controls, directly or indirectly, the person or any entity directly or indirectly under common control with the person. For this purpose, “control” of any entity or person means ownership of a majority of the voting power of the entity or person.

**“Agreement”** has the meaning specified in Section 1(c).

**“Applicable Close-out Rate”** means:—

(a) in respect of the determination of an Unpaid Amount:—

(i) in respect of obligations payable or deliverable (or which would have been but for Section 2(a)(iii)) by a Defaulting Party, the Default Rate;

(ii) in respect of obligations payable or deliverable (or which would have been but for Section 2(a)(iii)) by a Non-defaulting Party, the Non-default Rate;

(iii) in respect of obligations deferred pursuant to Section 5(d), if there is no Defaulting Party and for so long as the deferral period continues, the Applicable Deferral Rate; and

(iv) in all other cases following the occurrence of a Termination Event (except where interest accrues pursuant to clause (iii) above), the Applicable Deferral Rate; and

(b) in respect of an Early Termination Amount:—

(i) for the period from (and including) the relevant Early Termination Date to (but excluding) the date (determined in accordance with Section 6(d)(ii)) on which that amount is payable:—

(1) if the Early Termination Amount is payable by a Defaulting Party, the Default Rate;

(2) if the Early Termination Amount is payable by a Non-defaulting Party, the Non-default Rate; and

(3) in all other cases, the Applicable Deferral Rate; and

(ii) for the period from (and including) the date (determined in accordance with Section 6(d)(ii)) on which that amount is payable to (but excluding) the date of actual payment:—

- (1) if a party fails to pay the Early Termination Amount due to the occurrence of an event or circumstance which would, if it occurred with respect to a payment or delivery under a Transaction, constitute or give rise to an Illegality or a Force Majeure Event, and for so long as the Early Termination Amount remains unpaid due to the continuing existence of such event or circumstance, the Applicable Deferral Rate;
- (2) if the Early Termination Amount is payable by a Defaulting Party (but excluding any period in respect of which clause (1) above applies), the Default Rate;
- (3) if the Early Termination Amount is payable by a Non-defaulting Party (but excluding any period in respect of which clause (1) above applies), the Non-default Rate; and
- (4) in all other cases, the Termination Rate.

**“Applicable Deferral Rate”** means:—

- (a) for the purpose of Section 9(h)(i)(3)(A), the rate certified by the relevant payer to be a rate offered to the payer by a major bank in a relevant interbank market for overnight deposits in the applicable currency, such bank to be selected in good faith by the payer for the purpose of obtaining a representative rate that will reasonably reflect conditions prevailing at the time in that relevant market;
- (b) for purposes of Section 9(h)(i)(3)(B) and clause (a)(iii) of the definition of Applicable Close-out Rate, the rate certified by the relevant payer to be a rate offered to prime banks by a major bank in a relevant interbank market for overnight deposits in the applicable currency, such bank to be selected in good faith by the payer after consultation with the other party, if practicable, for the purpose of obtaining a representative rate that will reasonably reflect conditions prevailing at the time in that relevant market; and
- (c) for purposes of Section 9(h)(i)(3)(C) and clauses (a)(iv), (b)(i)(3) and (b)(ii)(1) of the definition of Applicable Close-out Rate, a rate equal to the arithmetic mean of the rate determined pursuant to clause (a) above and a rate per annum equal to the cost (without proof or evidence of any actual cost) to the relevant payee (as certified by it) if it were to fund or of funding the relevant amount.

**“Automatic Early Termination”** has the meaning specified in Section 6(a).

**“Burdened Party”** has the meaning specified in Section 5(b)(iv).

**“Change in Tax Law”** means the enactment, promulgation, execution or ratification of, or any change in or amendment to, any law (or in the application or official interpretation of any law) that occurs after the parties enter into the relevant Transaction.

**“Close-out Amount”** means, with respect to each Terminated Transaction or each group of Terminated Transactions and a Determining Party, the amount of the losses or costs of the Determining Party that are or would be incurred under then prevailing circumstances (expressed as a positive number) or gains of the Determining Party that are or would be realized under then prevailing circumstances (expressed as a negative number) in replacing, or in providing for the Determining Party the economic equivalent of, (a) the material terms of that Terminated Transaction or group of Terminated Transactions, including the payments and deliveries by the parties under Section 2(a)(i) in respect of that Terminated Transaction or group of Terminated Transactions that would, but for the occurrence of the relevant Early Termination Date, have been required after that date (assuming satisfaction of the conditions precedent in Section 2(a)(iii)) and (b) the option rights of the parties in respect of that Terminated Transaction or group of Terminated Transactions.

Any Close-out Amount will be determined by the Determining Party (or its agent), which will act in good faith and use commercially reasonable procedures in order to produce a commercially reasonable result. The Determining Party may determine a Close-out Amount for any group of Terminated Transactions or any individual Terminated Transaction but, in the aggregate, for not less than all Terminated Transactions. Each Close-out Amount will be determined as of the Early Termination Date or, if that would not be commercially reasonable, as of the date or dates following the Early Termination Date as would be commercially reasonable.

Unpaid Amounts in respect of a Terminated Transaction or group of Terminated Transactions and legal fees and out-of-pocket expenses referred to in Section 11 are to be excluded in all determinations of Close-out Amounts.

In determining a Close-out Amount, the Determining Party may consider any relevant information, including, without limitation, one or more of the following types of information:—

- (i) quotations (either firm or indicative) for replacement transactions supplied by one or more third parties that may take into account the creditworthiness of the Determining Party at the time the quotation is provided and the terms of any relevant documentation, including credit support documentation, between the Determining Party and the third party providing the quotation;
- (ii) information consisting of relevant market data in the relevant market supplied by one or more third parties including, without limitation, relevant rates, prices, yields, yield curves, volatilities, spreads, correlations or other relevant market data in the relevant market; or
- (iii) information of the types described in clause (i) or (ii) above from internal sources (including any of the Determining Party's Affiliates) if that information is of the same type used by the Determining Party in the regular course of its business for the valuation of similar transactions.

The Determining Party will consider, taking into account the standards and procedures described in this definition, quotations pursuant to clause (i) above or relevant market data pursuant to clause (ii) above unless the Determining Party reasonably believes in good faith that such quotations or relevant market data are not readily available or would produce a result that would not satisfy those standards. When considering information described in clause (i), (ii) or (iii) above, the Determining Party may include costs of funding, to the extent costs of funding are not and would not be a component of the other information being utilized. Third parties supplying quotations pursuant to clause (i) above or market data pursuant to clause (ii) above may include, without limitation, dealers in the relevant markets, end-users of the relevant product, information vendors, brokers and other sources of market information.

Without duplication of amounts calculated based on information described in clause (i), (ii) or (iii) above, or other relevant information, and when it is commercially reasonable to do so, the Determining Party may in addition consider in calculating a Close-out Amount any loss or cost incurred in connection with its terminating, liquidating or re-establishing any hedge related to a Terminated Transaction or group of Terminated Transactions (or any gain resulting from any of them).

Commercially reasonable procedures used in determining a Close-out Amount may include the following:—

- (1) application to relevant market data from third parties pursuant to clause (ii) above or information from internal sources pursuant to clause (iii) above of pricing or other valuation models that are, at the time of the determination of the Close-out Amount, used by the Determining Party in the regular course of its business in pricing or valuing transactions between the Determining Party and unrelated third parties that are similar to the Terminated Transaction or group of Terminated Transactions; and
- (2) application of different valuation methods to Terminated Transactions or groups of Terminated Transactions depending on the type, complexity, size or number of the Terminated Transactions or group of Terminated Transactions.

**“Confirmation”** has the meaning specified in the preamble.

**“consent”** includes a consent, approval, action, authorization, exemption, notice, filing, registration or exchange control consent.

**“Contractual Currency”** has the meaning specified in Section 8(a).

**“Convention Court”** means any court which is bound to apply to the Proceedings either Article 17 of the 1968 Brussels Convention on Jurisdiction and the Enforcement of Judgments in Civil and Commercial Matters or Article 17 of the 1988 Lugano Convention on Jurisdiction and the Enforcement of Judgments in Civil and Commercial Matters.

**“Credit Event Upon Merger”** has the meaning specified in Section 5(b).

**“Credit Support Document”** means any agreement or instrument that is specified as such in this Agreement.

**“Credit Support Provider”** has the meaning specified in the Schedule.

**“Cross-Default”** means the event specified in Section 5(a)(vi).

**“Default Rate”** means a rate per annum equal to the cost (without proof or evidence of any actual cost) to the relevant payee (as certified by it) if it were to fund or of funding the relevant amount plus 1% per annum.

**“Defaulting Party”** has the meaning specified in Section 6(a). **“Designated Event”** has the meaning specified in Section 5(b)(v). **“Determining Party”** means the party determining a Close-out Amount. **“Early Termination Amount”** has the meaning specified in Section 6(e).

**“Early Termination Date”** means the date determined in accordance with Section 6(a) or 6(b)(iv).

**“electronic messages”** does not include e-mails but does include documents expressed in markup languages, and

**“electronic messaging system”** will be construed accordingly.

**“English law”** means the law of England and Wales, and “English” will be construed accordingly. **“Event of Default”** has the meaning specified in Section 5(a) and, if applicable, in the Schedule. **“Force Majeure Event”** has the meaning specified in Section 5(b).

**“General Business Day”** means a day on which commercial banks are open for general business (including dealings in foreign exchange and foreign currency deposits).

**“Illegality”** has the meaning specified in Section 5(b).



**“Indemnifiable Tax”** means any Tax other than a Tax that would not be imposed in respect of a payment under this Agreement but for a present or former connection between the jurisdiction of the government or taxation authority imposing such Tax and the recipient of such payment or a person related to such recipient (including, without limitation, a connection arising from such recipient or related person being or having been a citizen or resident of such jurisdiction, or being or having been organised, present or engaged in a trade or business in such jurisdiction, or having or having had a permanent establishment or fixed place of business in such jurisdiction, but excluding a connection arising solely from such recipient or related person having executed, delivered, performed its obligations or received a payment under, or enforced, this Agreement or a Credit Support Document).

**“law”** includes any treaty, law, rule or regulation (as modified, in the case of tax matters, by the practice of any relevant governmental revenue authority), and **“unlawful”** will be construed accordingly.

**“Local Business Day”** means (a) in relation to any obligation under Section 2(a)(i), a General Business Day in the place or places specified in the relevant Confirmation and a day on which a relevant settlement system is open or operating as specified in the relevant Confirmation or, if a place or a settlement system is not so specified, as otherwise agreed by the parties in writing or determined pursuant to provisions contained, or incorporated by reference, in this Agreement, (b) for the purpose of determining when a Waiting Period expires, a General Business Day in the place where the event or circumstance that constitutes or gives rise to the Illegality or Force Majeure Event, as the case may be, occurs, (c) in relation to any other payment, a General Business Day in the place where the relevant account is located and, if different, in the principal financial centre, if any, of the currency of such payment and, if that currency does not have a single recognized principal financial centre, a day on which the settlement system necessary to accomplish such payment is open, (d) in relation to any notice or other communication, including notice contemplated under Section 5(a)(i), a General Business Day (or a day that would have been a General Business Day but for the occurrence of an event or circumstance which would, if it occurred with respect to payment, delivery or compliance related to a Transaction, constitute or give rise to an Illegality or a Force Majeure Event) in the place specified in the address for notice provided by the recipient and, in the case of a notice contemplated by Section 2(b), in the place where the relevant new account is to be located and (e) in relation to Section 5(a)(v)(2), a General Business Day in the relevant locations for performance with respect to such Specified Transaction.

**“Local Delivery Day”** means, for purposes of Sections 5(a)(i) and 5(d), a day on which settlement systems necessary to accomplish the relevant delivery are generally open for business so that the delivery is capable of being accomplished in accordance with customary market practice, in the place specified in the relevant Confirmation or, if not so specified, in a location as determined in accordance with customary market practice for the relevant delivery.

**“Master Agreement”** has the meaning specified in the preamble.

**“Merger Without Assumption”** means the event specified in Section 5(a)(viii). **“Multiple Transaction Payment Netting”** has the meaning specified in Section 2(c). **“Non-affected Party”** means, so long as there is only one Affected Party, the other party.

**“Non-default Rate”** means the rate certified by the Non-defaulting Party to be a rate offered to the Non-defaulting Party by a major bank in a relevant interbank market for overnight deposits in the applicable currency, such bank to be selected in good faith by the Non-defaulting Party for the purpose of obtaining a representative rate that will reasonably reflect conditions prevailing at the time in that relevant market.

**“Non-defaulting Party”** has the meaning specified in Section 6(a).

**“Office”** means a branch or office of a party, which may be such party’s head or home office.

**“Other Amounts”** has the meaning specified in Section 6(f).

**“Payee”** has the meaning specified in Section 6(f).

**“Payer”** has the meaning specified in Section 6(f).

**“Potential Event of Default”** means any event which, with the giving of notice or the lapse of time or both, would constitute an Event of Default.

**“Proceedings”** has the meaning specified in Section 13(b).

**“Process Agent”** has the meaning specified in the Schedule.

**“rate of exchange”** includes, without limitation, any premiums and costs of exchange payable in connection with the purchase of or conversion into the Contractual Currency.

**“Relevant Jurisdiction”** means, with respect to a party, the jurisdictions (a) in which the party is incorporated, organised, managed and controlled or considered to have its seat, (b) where an Office through which the party is acting for purposes of this Agreement is located, (c) in which the party executes this Agreement and (d) in relation to any payment, from or through which such payment is made.

**“Schedule”** has the meaning specified in the preamble.

**“Scheduled Settlement Date”** means a date on which a payment or delivery is to be made under Section 2(a)(i) with respect to a Transaction.

**“Specified Entity”** has the meaning specified in the Schedule.

**“Specified Indebtedness”** means, subject to the Schedule, any obligation (whether present or future, contingent or otherwise, as principal or surety or otherwise) in respect of borrowed money.

**“Specified Transaction”** means, subject to the Schedule, (a) any transaction (including an agreement with respect to any such transaction) now existing or hereafter entered into between one party to this Agreement (or any Credit Support Provider of such party or any applicable Specified Entity of such party) and the other party to this Agreement (or any Credit Support Provider of such other party or any applicable Specified Entity of such other party) which is not a Transaction under this Agreement but (i) which is a rate swap transaction, swap option, basis swap, forward rate transaction, commodity swap, commodity option, equity or equity index swap, equity or equity index option, bond option, interest rate option, foreign exchange transaction, cap transaction, floor transaction, collar transaction, currency swap transaction, cross-currency rate swap transaction, currency option, credit protection transaction, credit swap, credit default swap, credit default option, total return swap, credit spread transaction, repurchase transaction, reverse repurchase transaction, buy/sell-back transaction, securities lending transaction, weather index transaction or forward purchase or sale of a security, commodity or other financial instrument or interest (including any option with respect to any of these transactions) or (ii) which is a type of transaction that is similar to any transaction referred to in clause (i) above that is currently, or in the future becomes, recurrently entered into in the financial markets (including terms and conditions incorporated by reference in such agreement) and which is a forward, swap, future, option or other derivative on one or more rates, currencies, commodities, equity securities or other equity instruments, debt securities or other debt instruments, economic indices or measures of economic risk or value, or other benchmarks against which payments or deliveries are to be made, (b) any combination of these transactions and (c) any other transaction identified as a Specified Transaction in this Agreement or the relevant confirmation.

**“Stamp Tax”** means any stamp, registration, documentation or similar tax.

**“Stamp Tax Jurisdiction”** has the meaning specified in Section 4(e).

**“Tax”** means any present or future tax, levy, impost, duty, charge, assessment or fee of any nature (including interest, penalties and additions thereto) that is imposed by any government or other taxing authority in respect of any payment under this Agreement other than a stamp, registration, documentation or similar tax.

**“Tax Event”** has the meaning specified in Section 5(b).

**“Tax Event Upon Merger”** has the meaning specified in Section 5(b).

**“Terminated Transactions”** means, with respect to any Early Termination Date, (a) if resulting from an Illegality or a Force Majeure Event, all Affected Transactions specified in the notice given pursuant to Section 6(b)(iv), (b) if resulting from any other Termination Event, all Affected Transactions and (c) if resulting from an Event of Default, all Transactions in effect either immediately before the effectiveness of the notice designating that Early Termination Date or, if Automatic Early Termination applies, immediately before that Early Termination Date.

**“Termination Currency”** means (a) if a Termination Currency is specified in the Schedule and that currency is freely available, that currency, and (b) otherwise, Euro if this Agreement is expressed to be governed by English law or United States Dollars if this Agreement is expressed to be governed by the laws of the State of New York.

**“Termination Currency Equivalent”** means, in respect of any amount denominated in the Termination Currency, such Termination Currency amount and, in respect of any amount denominated in a currency other than the Termination Currency (the “Other Currency”), the amount in the Termination Currency determined by the party making the relevant determination as being required to purchase such amount of such Other Currency as at the relevant Early Termination Date, or, if the relevant Close-out Amount is determined as of a later date, that later date, with the Termination Currency at the rate equal to the spot exchange rate of the foreign exchange agent (selected as provided below) for the purchase of such Other Currency with the Termination Currency at or about 11:00 a.m. (in the city in which such foreign exchange agent is located) on such date as would be customary for the determination of such a rate for the purchase of such Other Currency for value on the relevant Early Termination Date or that later date. The foreign exchange agent will, if only one party is obliged to make a determination under Section 6(e), be selected in good faith by that party and otherwise will be agreed by the parties.

**“Termination Event”** means an Illegality, a Force Majeure Event, a Tax Event, a Tax Event Upon Merger or, if specified to be applicable, a Credit Event Upon Merger or an Additional Termination Event.

**“Termination Rate”** means a rate per annum equal to the arithmetic mean of the cost (without proof or evidence of any actual cost) to each party (as certified by such party) if it were to fund or of funding such amounts.

**“Threshold Amount”** means the amount, if any, specified as such in the Schedule.

**“Transaction”** has the meaning specified in the preamble.

**“Unpaid Amounts”** owing to any party means, with respect to an Early Termination Date, the aggregate of (a) in respect of all Terminated Transactions, the amounts that became payable (or that would have become payable but for Section 2(a)(iii) or due but for Section 5(d)) to such party under Section 2(a)(i) or 2(d)(i)(4) on or prior to such Early Termination Date and which remain unpaid as at such Early Termination Date, (b) in respect of each Terminated Transaction, for each obligation under Section 2(a)(i) which was (or would have been but for Section 2(a)(iii) or 5(d)) required to be settled by delivery to such party on or prior to such Early Termination Date and which has not been so settled as at such Early Termination Date, an amount equal to the fair market value of that which was (or would have been) required to be delivered and (c) if the Early Termination Date results from an Event of Default, a Credit Event Upon Merger or an Additional Termination Event in respect of which all outstanding Transactions are Affected Transactions, any Early Termination Amount due prior to such Early Termination Date and which remains unpaid as of such Early Termination Date, in each case together with any amount of interest accrued or other

compensation in respect of that obligation or deferred obligation, as the case may be, pursuant to Section 9(h)(ii)(1) or (2), as appropriate. The fair market value of any obligation referred to in clause (b) above will be determined as of the originally scheduled date for delivery, in good faith and using commercially reasonable procedures, by the party obliged to make the determination under Section 6(e) or, if each party is so obliged, it will be the average of the Termination Currency Equivalents of the fair market values so determined by both parties.

“Waiting Period” means:-

(a) in respect of an event or circumstance under Section S(b)(i), other than in the case of Section S(b)(i)(2) where the relevant payment, delivery or compliance is actually required on the relevant day (in which case no Waiting Period will apply), a period of three Local Business Days (or days that would have been Local Business Days but for the occurrence of that event or circumstance) following the occurrence of that event or circumstance; and

(b) in respect of an event or circumstance under Section S(b)(ii), other than in the case of Section 5(b)(ii)(2) where the relevant payment, delivery or compliance is actually required on the relevant day (in which case no Waiting Period will apply), a period of eight Local Business Days (or days that would have been Local Business Days but for the occurrence of that event or circumstance) following the occurrence of that event or circumstance.

IN WITNESS WHEREOF the parties have executed this document on the respective dates specified below with effect from the date specified on the first page of this document.

J. ARON & COMPANY LLC

MN AIRLINES, LLC

By: /s/ Rory Wisner  
Name: Rory Wisner  
Title: Attorney-in-Fact  
Date: May 8, 2019

By: /s/ William Trousdale  
Name: WILLIAM TROUSDALE  
Title: VP FP&A and Treasurer  
Date: 5/14/19



International Swaps and Derivatives Association, Inc.

**2002 MASTER AGREEMENT**

dated as of April 12, 2018

**MORGAN STANLEY CAPITAL SERVICES LLC**

and

**MN AIRLINES, LLC**

have entered and/or anticipate entering into one or more transactions (each a “Transaction”) that are or will be governed by this 2002 Master Agreement, which includes the schedule (the “Schedule”), and the documents and other confirming evidence (each a “Confirmation”) exchanged between the parties or otherwise effective for the purpose of confirming or evidencing those Transactions. This 2002 Master Agreement and the Schedule are together referred to as this “Master Agreement”.

Accordingly, the parties agree as follows:—

**1. Interpretation**

- (a) **Definitions.** The terms defined in Section 14 and elsewhere in this Master Agreement will have the meanings therein specified for the purpose of this Master Agreement.
- (b) **Inconsistency.** In the event of any inconsistency between the provisions of the Schedule and the other provisions of this Master Agreement, the Schedule will prevail. In the event of any inconsistency between the provisions of any Confirmation and this Master Agreement, such Confirmation will prevail for the purpose of the relevant Transaction.
- (c) **Single Agreement.** All Transactions are entered into in reliance on the fact that this Master Agreement and all Confirmations form a single agreement between the parties (collectively referred to as this “Agreement”), and the parties would not otherwise enter into any Transactions.

**2. Obligations**

- (a) **General Conditions.**
  - (i) Each party will make each payment or delivery specified in each Confirmation to be made by it, subject to the other provisions of this Agreement.
  - (ii) Payments under this Agreement will be made on the due date for value on that date in the place of the account specified in the relevant Confirmation or otherwise pursuant to this Agreement, in freely transferable funds and in the manner customary for payments in the required currency. Where settlement is by delivery (that is, other than by payment), such delivery will be made for receipt on the due date in the manner customary for the relevant obligation unless otherwise specified in the relevant Confirmation or elsewhere in this Agreement.

Copyright © 2002 by International Swaps and Derivatives Association, Inc.

(iii) Each obligation of each party under Section 2(a)(i) is subject to (1) the condition precedent that no Event of Default or Potential Event of Default with respect to the other party has occurred and is continuing, (2) the condition precedent that no Early Termination Date in respect of the relevant Transaction has occurred or been effectively designated and (3) each other condition specified in this Agreement to be a condition precedent for the purpose of this Section 2(a)(iii).

(b) **Change of Account.** Either party may change its account for receiving a payment or delivery by giving notice to the other party at least five Local Business Days prior to the Scheduled Settlement Date for the payment or delivery to which such change applies unless such other party gives timely notice of a reasonable objection to such change.

(c) **Netting of Payments.** If on any date amounts would otherwise be payable:—

- (i) in the same currency; and
- (ii) in respect of the same Transaction,

by each party to the other, then, on such date, each party's obligation to make payment of any such amount will be automatically satisfied and discharged and, if the aggregate amount that would otherwise have been payable by one party exceeds the aggregate amount that would otherwise have been payable by the other party, replaced by an obligation upon the party by which the larger aggregate amount would have been payable to pay to the other party the excess of the larger aggregate amount over the smaller aggregate amount.

The parties may elect in respect of two or more Transactions that a net amount and payment obligation will be determined in respect of all amounts payable on the same date in the same currency in respect of those Transactions, regardless of whether such amounts are payable in respect of the same Transaction. The election may be made in the Schedule or any Confirmation by specifying that "Multiple Transaction Payment Netting" applies to the Transactions identified as being subject to the election (in which case clause (ii) above will not apply to such Transactions). If Multiple Transaction Payment Netting is applicable to Transactions, it will apply to those Transactions with effect from the starting date specified in the Schedule or such Confirmation, or, if a starting date is not specified in the Schedule or such Confirmation, the starting date otherwise agreed by the parties in writing. This election may be made separately for different groups of Transactions and will apply separately to each pairing of Offices through which the parties make and receive payments or deliveries.

(d) **Deduction or Withholding/or Tax.**

(i) **Gross-Up.** All payments under this Agreement will be made without any deduction or withholding for or on account of any Tax unless such deduction or withholding is required by any applicable law, as modified by the practice of any relevant governmental revenue authority, then in effect. If a party is so required to deduct or withhold, then that party ("X") will—

- (1) promptly notify the other party ("Y") of such requirement;
- (2) pay to the relevant authorities the full amount required to be deducted or withheld (including the full amount required to be deducted or withheld from any additional amount paid by X to Y under this Section 2(d)) promptly upon the earlier of determining that such deduction or withholding is required or receiving notice that such amount has been assessed against Y;
- (3) promptly forward to Y an official receipt (or a certified copy), or other documentation reasonably acceptable to Y, evidencing such payment to such authorities; and

(4) if such Tax is an Indemnifiable Tax, pay to Y, in addition to the payment to which Y is otherwise entitled under this Agreement, such additional amount as is necessary to ensure that the net amount actually received by Y (free and clear of Indemnifiable Taxes, whether assessed against X or Y) will equal the full amount Y would have received had no such deduction or withholding been required. However, X will not be required to pay any additional amount to Y to the extent that it would not be required to be paid but for:—

(A) the failure by Y to comply with or perform any agreement contained in Section 4(a)(i), 4(a)(iii) or 4(d); or

(B) the failure of a representation made by Y pursuant to Section 3(f) to be accurate and true unless such failure would not have occurred but for (I) any action taken by a taxing authority, or brought in a court of competent jurisdiction, after a Transaction is entered into (regardless of whether such action is taken or brought with respect to a party to this Agreement) or (II) a Change in Tax Law.

(ii) **Liability.** It:—

(1) X is required by any applicable law, as modified by the practice of any relevant governmental revenue authority, to make any deduction or withholding in respect of which X would not be required to pay an additional amount to Y under Section 2(d)(i)(4);

(2) X does not so deduct or withhold; and

(3) a liability resulting from such Tax is assessed directly against X,

then, except to the extent Y has satisfied or then satisfies the liability resulting from such Tax, Y will promptly pay to X the amount of such liability (including any related liability for interest, but including any related liability for penalties only if Y has failed to comply with or perform any agreement contained in Section 4(a)(i), 4(a)(iii) or 4(d)).

### 3. Representations

Each party makes the representations contained in Sections 3(a), 3(b), 3(c), 3(d), 3(e) and 3(f) and, if specified in the Schedule as applying, 3(g) to the other party (which representations will be deemed to be repeated by each party on each date on which a Transaction is entered into and, in the case of the representations in Section 3(f), at all times until the termination of this Agreement). If any “Additional Representation” is specified in the Schedule or any Confirmation as applying, the party or parties specified for such Additional Representation will make and, if applicable, be deemed to repeat such Additional Representation at the time or times specified for such Additional Representation.

(a) **Basic Representations.**

(i) **Status.** It is duly organised and validly existing under the laws of the jurisdiction of its organization or incorporation and, if relevant under such laws, in good standing;

(ii) **Powers.** It has the power to execute this Agreement and any other documentation relating to this Agreement to which it is a party, to deliver this Agreement and any other documentation relating to this Agreement that it is required by this Agreement to deliver and to perform its obligations under this Agreement and any obligations it has under any Credit Support Document to which it is a party and has taken all necessary action to authorize such execution, delivery and performance;

- (iii) **No Violation or Conflict.** Such execution, delivery and performance do not violate or conflict with any law applicable to it, any provision of its constitutional documents, any order or judgment of any court or other agency of government applicable to it or any of its assets or any contractual restriction binding on or affecting it or any of its assets;
- (iv) **Consents.** All governmental and other consents that are required to have been obtained by it with respect to this Agreement or any Credit Support Document to which it is a party have been obtained and are in full force and effect and all conditions of any such consents have been complied with; and
- (v) **Obligations Binding.** Its obligations under this Agreement and any Credit Support Document to which it is a party constitute its legal, valid and binding obligations, enforceable in accordance with their respective terms (subject to applicable bankruptcy, reorganization, insolvency, moratorium or similar laws affecting creditors' rights generally and subject, as to enforceability, to equitable principles of general application (regardless of whether enforcement is sought in a proceeding in equity or at law)).
- (b) **Absence of Certain Events.** No Event of Default or Potential Event of Default or, to its knowledge, Termination Event with respect to it has occurred and is continuing and no such event or circumstance would occur as a result of its entering into or performing its obligations under this Agreement or any Credit Support Document to which it is a party.
- (c) **Absence of Litigation.** There is not pending or, to its knowledge, threatened against it, any of its Credit Support Providers or any of its applicable Specified Entities any action, suit or proceeding at law or in equity or before any court, tribunal, governmental body, agency or official or any arbitrator that is likely to affect the legality, validity or enforceability against it of this Agreement or any Credit Support Document to which it is a party or its ability to perform its obligations under this Agreement or such Credit Support Document.
- (d) **Accuracy of Specified Information.** All applicable information that is furnished in writing by or on behalf of it to the other party and is identified for the purpose of this Section 3(d) in the Schedule is, as of the date of the information, true, accurate and complete in every material respect.
- (e) **Payer Tax Representation.** Each representation specified in the Schedule as being made by it for the purpose of this Section 3(e) is accurate and true.
- (f) **Payee Tax Representations.** Each representation specified in the Schedule as being made by it for the purpose of this Section 3(f) is accurate and true.
- (g) **No Agency.** It is entering into this Agreement, including each Transaction, as principal and not as agent of any person or entity.

#### 4. Agreements

Each party agrees with the other that, so long as either party has or may have any obligation under this Agreement or under any Credit Support Document to which it is a party:—

- (a) **Furnish Specified Information.** It will deliver to the other party or, in certain cases under clause (iii) below, to such government or taxing authority as the other party reasonably directs:—
- (i) any forms, documents or certificates relating to taxation specified in the Schedule or any Confirmation;
  - (ii) any other documents specified in the Schedule or any Confirmation; and



(iii) upon reasonable demand by such other party, any form or document that may be required or reasonably requested in writing in order to allow such other party or its Credit Support Provider to make a payment under this Agreement or any applicable Credit Support Document without any deduction or withholding for or on account of any Tax or with such deduction or withholding at a reduced rate (so long as the completion, execution or submission of such form or document would not materially prejudice the legal or commercial position of the party in receipt of such demand), with any such form or document to be accurate and completed in a manner reasonably satisfactory to such other party and to be executed and to be delivered with any reasonably required certification,

in each case by the date specified in the Schedule or such Confirmation or, if none is specified, as soon as reasonably practicable.

(b) **Maintain Authorisations.** It will use all reasonable efforts to maintain in full force and effect all consents of any governmental or other authority that are required to be obtained by it with respect to this Agreement or any Credit Support Document to which it is a party and will use all reasonable efforts to obtain any that may become necessary in the future.

(c) **Comply With Laws.** It will comply in all material respects with all applicable laws and orders to which it may be subject if failure so to comply would materially impair its ability to perform its obligations under this Agreement or any Credit Support Document to which it is a party.

(d) **Tax Agreement.** It will give notice of any failure of a representation made by it under Section 3(f) to be accurate and true promptly upon learning of such failure.

(e) **Payment of Stamp Tax.** Subject to Section 11, it will pay any Stamp Tax levied or imposed upon it or in respect of its execution or performance of this Agreement by a jurisdiction in which it is incorporated, organised, managed and controlled or considered to have its seat, or where an Office through which it is acting for the purpose of this Agreement is located (“Stamp Tax Jurisdiction”), and will indemnify the other party against any Stamp Tax levied or imposed upon the other party or in respect of the other party’s execution or performance of this Agreement by any such Stamp Tax Jurisdiction which is not also a Stamp Tax Jurisdiction with respect to the other party.

## 5. Events of Default and Termination Events

(a) **Events of Default.** The occurrence at any time with respect to a party or, if applicable, any Credit Support Provider of such party or any Specified Entity of such party of any of the following events constitutes (subject to Sections 5(c) and 6(e)(iv)) an event of default (an “Event of Default”) with respect to such party:—

(i) **Failure to Pay or Deliver.** Failure by the party to make, when due, any payment under this Agreement or delivery under Section 2(a)(i) or 9(h)(i)(2) or (4) required to be made by it if such failure is not remedied on or before the first Local Business Day in the case of any such payment or the first Local Delivery Day in the case of any such delivery after, in each case, notice of such failure is given to the party;

(ii) **Breach of Agreement; Repudiation of Agreement.**

(1) Failure by the party to comply with or perform any agreement or obligation (other than an obligation to make any payment under this Agreement or delivery under Section 2(a)(i) or 9(h)(i)(2) or (4) or to give notice of a Termination Event or any agreement or obligation under Section 4(a)(i), 4(a)(iii) or 4(d)) to be complied with or performed by the party in accordance with this Agreement if such failure is not remedied within 30 days after notice of such failure is given to the party; or

(2) the party disaffirms, disclaims, repudiates or rejects, in whole or in part, or challenges the validity of, this Master Agreement, any Confirmation executed and delivered by that party or any Transaction evidenced by such a Confirmation (or such action is taken by any person or entity appointed or empowered to operate it or act on its behalf);

(iii) **Credit Support Default.**

- (1) Failure by the party or any Credit Support Provider of such party to comply with or perform any agreement or obligation to be complied with or performed by it in accordance with any Credit Support Document if such failure is continuing after any applicable grace period has elapsed;
- (2) the expiration or termination of such Credit Support Document or the failing or ceasing of such Credit Support Document, or any security interest granted by such party or such Credit Support Provider to the other party pursuant to any such Credit Support Document, to be in full force and effect for the purpose of this Agreement (in each case other than in accordance with its terms) prior to the satisfaction of all obligations of such party under each Transaction to which such Credit Support Document relates without the written consent of the other party; or
- (3) the party or such Credit Support Provider disaffirms, disclaims, repudiates or rejects, in whole or in part, or challenges the validity of, such Credit Support Document (or such action is taken by any person or entity appointed or empowered to operate it or act on its behalf);

(iv) **Misrepresentation.** A representation (other than a representation under Section 3(e) or 3(f)) made or repeated or deemed to have been made or repeated by the party or any Credit Support Provider of such party in this Agreement or any Credit Support Document proves to have been incorrect or misleading in any material respect when made or repeated or deemed to have been made or repeated;

(v) **Default Under Specified Transaction.** The party, any Credit Support Provider of such party or any applicable Specified Entity of such party:—

- (1) defaults (other than by failing to make a delivery) under a Specified Transaction or any credit support arrangement relating to a Specified Transaction and, after giving effect to any applicable notice requirement or grace period, such default results in a liquidation of, an acceleration of obligations under, or an early termination of, that Specified Transaction;
- (2) defaults, after giving effect to any applicable notice requirement or grace period, in making any payment due on the last payment or exchange date of, or any payment on early termination of, a Specified Transaction (or, if there is no applicable notice requirement or grace period, such default continues for at least one Local Business Day);
- (3) defaults in making any delivery due under (including any delivery due on the last delivery or exchange date of) a Specified Transaction or any credit support arrangement relating to a Specified Transaction and, after giving effect to any applicable notice requirement or grace period, such default results in a liquidation of, an acceleration of obligations under, or an early termination of, all transactions outstanding under the documentation applicable to that Specified Transaction; or
- (4) disaffirms, disclaims, repudiates or rejects, in whole or in part, or challenges the validity of, a Specified Transaction or any credit support arrangement relating to a Specified Transaction that is, in either case, confirmed or evidenced by a document or other confirming evidence executed and delivered by that party, Credit Support Provider or Specified Entity (or such action is taken by any person or entity appointed or empowered to operate it or act on its behalf);

(vi) **Cross-Default.** If “Cross-Default” is specified in the Schedule as applying to the party, the occurrence or existence of:—

(1) a default, event of default or other similar condition or event (however described) in respect of such party, any Credit Support Provider of such party or any applicable Specified Entity of such party under one or more agreements or instruments relating to Specified Indebtedness of any of them (individually or collectively) where the aggregate principal amount of such agreements or instruments, either alone or together with the amount, if any, referred to in clause (2) below, is not less than the applicable Threshold Amount (as specified in the Schedule) which has resulted in such Specified Indebtedness becoming, or becoming capable at such time of being declared, due and payable under such agreements or instruments before it would otherwise have been due and payable; or

(2) a default by such party, such Credit Support Provider or such Specified Entity (individually or collectively) in making one or more payments under such agreements or instruments on the due date for payment (after giving effect to any applicable notice requirement or grace period) in an aggregate amount, either alone or together with the amount, if any, referred to in clause (1) above, of not less than the applicable Threshold Amount;

(vii) **Bankruptcy.** The party, any Credit Support Provider of such party or any applicable Specified Entity of such party:—

(1) is dissolved (other than pursuant to a consolidation, amalgamation or merger); (2) becomes insolvent or is unable to pay its debts or fails or admits in writing its inability generally to pay its debts as they become due; (3) makes a general assignment, arrangement or composition with or for the benefit of its creditors; (4)(A) institutes or has instituted against it, by a regulator, supervisor or any similar official with primary insolvency, rehabilitative or regulatory jurisdiction over it in the jurisdiction of its incorporation or organization or the jurisdiction of its head or home office, a proceeding seeking a judgment of insolvency or bankruptcy or any other relief under any bankruptcy or insolvency law or other similar law affecting creditors’ rights, or a petition is presented for its winding-up or liquidation by it or such regulator, supervisor or similar official, or (B) has instituted against it a proceeding seeking a judgment of insolvency or bankruptcy or any other relief under any bankruptcy or insolvency law or other similar law affecting creditors’ rights, or a petition is presented for its winding-up or liquidation, and such proceeding or petition is instituted or presented by a person or entity not described in clause (A) above and either (I) results in a judgment of insolvency or bankruptcy or the entry of an order for relief or the making of an order for its winding-up or liquidation or (II) is not dismissed, discharged, stayed or restrained in each case within 15 days of the institution or presentation thereof; (5) has a resolution passed for its winding-up, official management or liquidation (other than pursuant to a consolidation, amalgamation or merger); (6) seeks or becomes subject to the appointment of an administrator, provisional liquidator, conservator, receiver, trustee, custodian or other similar official for it or for all or substantially all its assets; (7) has a secured party take possession of all or substantially all its assets or has a distress, execution, attachment, sequestration or other legal process levied, enforced or sued on or against all or substantially all its assets and such secured party maintains possession, or any such process is not dismissed, discharged, stayed or restrained, in each case within 15 days thereafter; (8) causes or is subject to any event with respect to it which, under the applicable laws of any jurisdiction, has an analogous effect to any of the events specified in clauses (I) to (7) above (inclusive); or (9) takes any action in furtherance of, or indicating its consent to, approval of, or acquiescence in, any of the foregoing acts; or

(viii) **Merger Without Assumption.** The party or any Credit Support Provider of such party consolidates or amalgamates with, or merges with or into, or transfers all or substantially all its assets to, or reorganizes, reincorporates or reconstitutes into or as, another entity and, at the time of such consolidation, amalgamation, merger, transfer, reorganization, reincorporation or reconstitution:—

- (1) the resulting, surviving or transferee entity fails to assume all the obligations of such party or such Credit Support Provider under this Agreement or any Credit Support Document to which it or its predecessor was a party; or
- (2) the benefits of any Credit Support Document fail to extend (without the consent of the other party) to the performance by such resulting, surviving or transferee entity of its obligations under this Agreement.

(b) **Termination Events.** The occurrence at any time with respect to a party or, if applicable, any Credit Support Provider of such party or any Specified Entity of such party of any event specified below constitutes (subject to Section 5(c)) an Illegality if the event is specified in clause (i) below, a Force Majeure Event if the event is specified in clause (ii) below, a Tax Event if the event is specified in clause (iii) below, a Tax Event Upon Merger if the event is specified in clause (iv) below, and, if specified to be applicable, a Credit Event Upon Merger if the event is specified pursuant to clause (v) below or an Additional Termination Event if the event is specified pursuant to clause (vi) below:—

(i) **Illegality.** After giving effect to any applicable provision, disruption fallback or remedy specified in, or pursuant to, the relevant Confirmation or elsewhere in this Agreement, due to an event or circumstance (other than any action taken by a party or, if applicable, any Credit Support Provider of such party) occurring after a Transaction is entered into, it becomes unlawful under any applicable law (including without limitation the laws of any country in which payment, delivery or compliance is required by either party or any Credit Support Provider, as the case may be), on any day, or it would be unlawful if the relevant payment, delivery or compliance were required on that day (in each case, other than as a result of a breach by the party of Section 4(b)):—

- (1) for the Office through which such party (which will be the Affected Party) makes and receives payments or deliveries with respect to such Transaction to perform any absolute or contingent obligation to make a payment or delivery in respect of such Transaction, to receive a payment or delivery in respect of such Transaction or to comply with any other material provision of this Agreement relating to such Transaction; or
- (2) for such party or any Credit Support Provider of such party (which will be the Affected Party) to perform any absolute or contingent obligation to make a payment or delivery which such party or Credit Support Provider has under any Credit Support Document relating to such Transaction, to receive a payment or delivery under such Credit Support Document or to comply with any other material provision of such Credit Support Document;

(ii) **Force Majeure Event.** After giving effect to any applicable provision, disruption fallback or remedy specified in, or pursuant to, the relevant Confirmation or elsewhere in this Agreement, by reason of force majeure or act of state occurring after a Transaction is entered into, on any day:—

- (1) the Office through which such party (which will be the Affected Party) makes and receives payments or deliveries with respect to such Transaction is prevented from performing any absolute or contingent obligation to make a payment or delivery in respect of such Transaction, from receiving a payment or delivery in respect of such Transaction or from complying with any other material provision of this Agreement relating to such Transaction (or would be so prevented if such payment, delivery or compliance were required on that day), or it becomes impossible or

impracticable for such Office so to perform, receive or comply (or it would be impossible or impracticable for such Office so to perform, receive or comply if such payment, delivery or compliance were required on that day); or

(2) such party or any Credit Support Provider of such party (which will be the Affected Party) is prevented from performing any absolute or contingent obligation to make a payment or delivery which such party or Credit Support Provider has under any Credit Support Document relating to such Transaction, from receiving a payment or delivery under such Credit Support Document or from complying with any other material provision of such Credit Support Document (or would be so prevented if such payment, delivery or compliance were required on that day), or it becomes impossible or impracticable for such party or Credit Support Provider so to perform, receive or comply (or it would be impossible or impracticable for such party or Credit Support Provider so to perform, receive or comply if such payment, delivery or compliance were required on that day),

so long as the force majeure or act of state is beyond the control of such Office, such party or such Credit Support Provider, as appropriate, and such Office, party or Credit Support Provider could not, after using all reasonable efforts (which will not require such party or Credit Support Provider to incur a loss, other than immaterial, incidental expenses), overcome such prevention, impossibility or impracticability;

(iii) **Tax Event.** Due to (1) any action taken by a taxing authority, or brought in a court of competent jurisdiction, after a Transaction is entered into (regardless of whether such action is taken or brought with respect to a party to this Agreement) or (2) a Change in Tax Law, the party (which will be the Affected Party) will, or there is a substantial likelihood that it will, on the next succeeding Scheduled Settlement Date (A) be required to pay to the other party an additional amount in respect of an Indemnifiable Tax under Section 2(d)(i)(4) (except in respect of interest under Section 9(h)) or (B) receive a payment from which an amount is required to be deducted or withheld for or on account of a Tax (except in respect of interest under Section 9(h)) and no additional amount is required to be paid in respect of such Tax under Section 2(d)(i)(4) (other than by reason of Section 2(d)(i)(4)(A) or (B));

(iv) **Tax Event Upon Merger.** The party (the “Burdened Party”) on the next succeeding Scheduled Settlement Date will either (1) be required to pay an additional amount in respect of an Indemnifiable Tax under Section 2(d)(i)(4) (except in respect of interest under Section 9(h)) or (2) receive a payment from which an amount has been deducted or withheld for or on account of any Tax in respect of which the other party is not required to pay an additional amount (other than by reason of Section 2(d)(i)(4)(A) or (B)), in either case as a result of a party consolidating or amalgamating with, or merging with or into, or transferring all or substantially all its assets (or any substantial part of the assets comprising the business conducted by it as of the date of this Master Agreement) to, or reorganizing, reincorporating or reconstituting into or as, another entity (which will be the Affected Party) where such action does not constitute a Merger Without Assumption;

(v) **Credit Event Upon Merger.** If “Credit Event Upon Merger” is specified in the Schedule as applying to the party, a Designated Event (as defined below) occurs with respect to such party, any Credit Support Provider of such party or any applicable Specified Entity of such party (in each case, “X”) and such Designated Event does not constitute a Merger Without Assumption, and the creditworthiness of X or, if applicable, the successor, surviving or transferee entity of X, after taking into account any applicable Credit Support Document, is materially weaker immediately after the occurrence of such Designated Event than that of X immediately prior to the occurrence of such Designated Event (and, in any such event, such party or its successor, surviving or transferee entity, as appropriate, will be the Affected Party). A “Designated Event” with respect to X means that:—

(1) X consolidates or amalgamates with, or merges with or into, or transfers all or substantially all its assets (or any substantial part of the assets comprising the business conducted by X as of the date of this Master Agreement) to, or reorganizes, reincorporates or reconstitutes into or as, another entity;

(2) any person, related group of persons or entity acquires directly or indirectly the beneficial ownership of (A) equity securities having the power to elect a majority of the board of directors (or its equivalent) of X or (B) any other ownership interest enabling it to exercise control of X; or

(3) X effects any substantial change in its capital structure by means of the issuance, incurrence or guarantee of debt or the issuance of (A) preferred stock or other securities convertible into or exchangeable for debt or preferred stock or (B) in the case of entities other than corporations, any other form of ownership interest; or

(vi) **Additional Termination Event.** If any “Additional Termination Event” is specified in the Schedule or any Confirmation as applying, the occurrence of such event (and, in such event, the Affected Party or Affected Parties will be as specified for such Additional Termination Event in the Schedule or such Confirmation).

(c) **Hierarchy of Events.**

(i) An event or circumstance that constitutes or gives rise to an Illegality or a Force Majeure Event will not, for so long as that is the case, also constitute or give rise to an Event of Default under Section 5(a)(i), 5(a)(ii)(I) or 5(a)(iii)(I) insofar as such event or circumstance relates to the failure to make any payment or delivery or a failure to comply with any other material provision of this Agreement or a Credit Support Document, as the case may be.

(ii) Except in circumstances contemplated by clause (i) above, if an event or circumstance which would otherwise constitute or give rise to an Illegality or a Force Majeure Event also constitutes an Event of Default or any other Termination Event, it will be treated as an Event of Default or such other Termination Event, as the case may be, and will not constitute or give rise to an Illegality or a Force Majeure Event.

(iii) If an event or circumstance which would otherwise constitute or give rise to a Force Majeure Event also constitutes an Illegality, it will be treated as an Illegality, except as described in clause (ii) above, and not a Force Majeure Event.

(d) **Deferral of Payments and Deliveries During Waiting Period.** If an Illegality or a Force Majeure Event has occurred and is continuing with respect to a Transaction, each payment or delivery which would otherwise be required to be made under that Transaction will be deferred to, and will not be due until:—

(i) the first Local Business Day or, in the case of a delivery, the first Local Delivery Day (or the first day that would have been a Local Business Day or Local Delivery Day, as appropriate, but for the occurrence of the event or circumstance constituting or giving rise to that Illegality or Force Majeure Event) following the end of any applicable Waiting Period in respect of that Illegality or Force Majeure Event, as the case may be; or

(ii) if earlier, the date on which the event or circumstance constituting or giving rise to that Illegality or Force Majeure Event ceases to exist or, if such date is not a Local Business Day or, in the case of a delivery, a Local Delivery Day, the first following day that is a Local Business Day or Local Delivery Day, as appropriate.

(e) **Inability of Head or Home Office to Perform Obligations of Branch.** If (i) an Illegality or a Force Majeure Event occurs under Section 5(b)(i)(I) or 5(b)(ii)(I) and the relevant Office is not the Affected Party’s head or home office, (ii) Section 10(a) applies, (iii) the other party seeks performance of the relevant obligation or

compliance with the relevant provision by the Affected Party's head or home office and (iv) the Affected Party's head or home office fails so to perform or comply due to the occurrence of an event or circumstance which would, if that head or home office were the Office through which the Affected Party makes and receives payments and deliveries with respect to the relevant Transaction, constitute or give rise to an Illegality or a Force Majeure Event, and such failure would otherwise constitute an Event of Default under Section 5(a)(i) or 5(a)(iii)(1) with respect to such party, then, for so long as the relevant event or circumstance continues to exist with respect to both the Office referred to in Section 5(b)(i)(1) or 5(b)(iii)(1), as the case may be, and the Affected Party's head or home office, such failure will not constitute an Event of Default under Section 5(a)(i) or 5(a)(iii)(1).

## 6. Early Termination; Close-Out Netting

(a) **Right to Terminate Following Event of Default.** If at any time an Event of Default with respect to a party (the "Defaulting Party") has occurred and is then continuing, the other party (the "Non-defaulting Party") may, by not more than 20 days notice to the Defaulting Party specifying the relevant Event of Default, designate a day not earlier than the day such notice is effective as an Early Termination Date in respect of all outstanding Transactions. If, however, "Automatic Early Termination" is specified in the Schedule as applying to a party, then an Early Termination Date in respect of all outstanding Transactions will occur immediately upon the occurrence with respect to such party of an Event of Default specified in Section 5(a)(vii)(1), (3), (5), (6) or, to the extent analogous thereto, (8), and as of the time immediately preceding the institution of the relevant proceeding or the presentation of the relevant petition upon the occurrence with respect to such party of an Event of Default specified in Section 5(a)(vii)(4) or, to the extent analogous thereto, (8).

### (b) Right to Terminate Following Termination Event.

(i) **Notice.** If a Termination Event other than a Force Majeure Event occurs, an Affected Party will, promptly upon becoming aware of it, notify the other party, specifying the nature of that Termination Event and each Affected Transaction, and will also give the other party such other information about that Termination Event as the other party may reasonably require. If a Force Majeure Event occurs, each party will, promptly upon becoming aware of it, use all reasonable efforts to notify the other party, specifying the nature of that Force Majeure Event, and will also give the other party such other information about that Force Majeure Event as the other party may reasonably require.

(ii) **Transfer to Avoid Termination Event.** If a Tax Event occurs and there is only one Affected Party, or if a Tax Event Upon Merger occurs and the Burdened Party is the Affected Party, the Affected Party will, as a condition to its right to designate an Early Termination Date under Section 6(b)(iv), use all reasonable efforts (which will not require such party to incur a loss, other than immaterial, incidental expenses) to transfer within 20 days after it gives notice under Section 6(b)(i) all its rights and obligations under this Agreement in respect of the Affected Transactions to another of its Offices or Affiliates so that such Termination Event ceases to exist.

If the Affected Party is not able to make such a transfer it will give notice to the other party to that effect within such 20 day period, whereupon the other party may effect such a transfer within 30 days after the notice is given under Section 6(b)(i).

Any such transfer by a party under this Section 6(b)(ii) will be subject to and conditional upon the prior written consent of the other party, which consent will not be withheld if such other party's policies in effect at such time would permit it to enter into transactions with the transferee on the terms proposed.

(iii) **Two Affected Parties.** If a Tax Event occurs and there are two Affected Parties, each party will use all reasonable efforts to reach agreement within 30 days after notice of such occurrence is given under Section 6(b)(i) to avoid that Termination Event.

(iv) **Right to Terminate.**

(1) If:—

(A) a transfer under Section 6(b)(ii) or an agreement under Section 6(b)(iii), as the case may be, has not been effected with respect to all Affected Transactions within 30 days after an Affected Party gives notice under Section 6(b)(i); or

(B) a Credit Event Upon Merger or an Additional Termination Event occurs, or a Tax Event Upon Merger occurs and the Burdened Party is not the Affected Party,

the Burdened Party in the case of a Tax Event Upon Merger, any Affected Party in the case of a Tax Event or an Additional Termination Event if there are two Affected Parties, or the Non-affected Party in the case of a Credit Event Upon Merger or an Additional Termination Event if there is only one Affected Party may, if the relevant Termination Event is then continuing, by not more than 20 days notice to the other party, designate a day not earlier than the day such notice is effective as an Early Termination Date in respect of all Affected Transactions.

(2) If at any time an Illegality or a Force Majeure Event has occurred and is then continuing and any applicable Waiting Period has expired:—

(A) Subject to clause (B) below, either party may, by not more than 20 days notice to the other party, designate (I) a day not earlier than the day on which such notice becomes effective as an Early Termination Date in respect of all Affected Transactions or (II) by specifying in that notice the Affected Transactions in respect of which it is designating the relevant day as an Early Termination Date, a day not earlier than two Local Business Days following the day on which such notice becomes effective as an Early Termination Date in respect of less than all Affected Transactions. Upon receipt of a notice designating an Early Termination Date in respect of less than all Affected Transactions, the other party may, by notice to the designating party, if such notice is effective on or before the day so designated, designate that same day as an Early Termination Date in respect of any or all other Affected Transactions.

(B) An Affected Party (if the Illegality or Force Majeure Event relates to performance by such party or any Credit Support Provider of such party of an obligation to make any payment or delivery under, or to compliance with any other material provision of, the relevant Credit Support Document) will only have the right to designate an Early Termination Date under Section 6(b)(iv)(2) (A) as a result of an Illegality under Section 5(b)(i)(2) or a Force Majeure Event under Section 5(b)(ii)(2) following the prior designation by the other party of an Early Termination Date, pursuant to Section 6(b)(iv)(2)(A), in respect of less than all Affected Transactions.

(c) **Effect of Designation.**

(i) If notice designating an Early Termination Date is given under Section 6(a) or 6(b), the Early Termination Date will occur on the date so designated, whether or not the relevant Event of Default or Termination Event is then continuing.

(ii) Upon the occurrence or effective designation of an Early Termination Date, no further payments or deliveries under Section 2(a)(i) or 9(h)(i) in respect of the Terminated Transactions will be required to be made, but without prejudice to the other provisions of this Agreement. The amount, if any, payable in respect of an Early Termination Date will be determined pursuant to Sections 6(e) and 9(h)(ii).



(d) **Calculations; Payment Date.**

(i) **Statement.** On or as soon as reasonably practicable following the occurrence of an Early Termination Date, each party will make the calculations on its part, if any, contemplated by Section 6(e) and will provide to the other party a statement (1) showing, in reasonable detail, such calculations (including any quotations, market data or information from internal sources used in making such calculations), (2) specifying (except where there are two Affected Parties) any Early Termination Amount payable and (3) giving details of the relevant account to which any amount payable to it is to be paid. In the absence of written confirmation from the source of a quotation or market data obtained in determining a Close-out Amount, the records of the party obtaining such quotation or market data will be conclusive evidence of the existence and accuracy of such quotation or market data.

(ii) **Payment Date.** An Early Termination Amount due in respect of any Early Termination Date will, together with any amount of interest payable pursuant to Section 9(h)(ii)(2), be payable (1) on the day on which notice of the amount payable is effective in the case of an Early Termination Date which is designated or occurs as a result of an Event of Default and (2) on the day which is two Local Business Days after the day on which notice of the amount payable is effective (or, if there are two Affected Parties, after the day on which the statement provided pursuant to clause (i) above by the second party to provide such a statement is effective) in the case of an Early Termination Date which is designated as a result of a Termination Event.

(e) **Payments on Early Termination.** If an Early Termination Date occurs, the amount, if any, payable in respect of that Early Termination Date (the "Early Termination Amount") will be determined pursuant to this Section 6(e) and will be subject to Section 6(f).

(i) **Events of Default.** If the Early Termination Date results from an Event of Default, the Early Termination Amount will be an amount equal to (1) the sum of (A) the Termination Currency Equivalent of the Close-out Amount or Close-out Amounts (whether positive or negative) determined by the Non-defaulting Party for each Terminated Transaction or group of Terminated Transactions, as the case may be, and (B) the Termination Currency Equivalent of the Unpaid Amounts owing to the Non-defaulting Party less (2) the Termination Currency Equivalent of the Unpaid Amounts owing to the Defaulting Party. If the Early Termination Amount is a positive number, the Defaulting Party will pay it to the Non-defaulting Party; if it is a negative number, the Non-defaulting Party will pay the absolute value of Early Termination Amount to the Defaulting Party.

(ii) **Termination Events.** If the Early Termination Date results from a Termination Event:—

(1) **One Affected Party.** Subject to clause (3) below, if there is one Affected Party, the Early Termination Amount will be determined in accordance with Section 6(e)(i), except that references to the Defaulting Party and to the Non-defaulting Party will be deemed to be references to the Affected Party and to the Non-affected Party, respectively.

(2) **Two Affected Parties.** Subject to clause (3) below, if there are two Affected Parties, each party will determine an amount equal to the Termination Currency Equivalent of the sum of the Close-out Amount or Close-out Amounts (whether positive or negative) for each Terminated Transaction or group of Terminated Transactions, as the case may be, and the Early Termination Amount will be an amount equal to (A) the sum of (I) one-half of the difference between the higher amount so determined (by party "X") and lower amount so determined (by party "Y") and (II) the Termination Currency Equivalent of the Unpaid Amounts owing to X less (B) the Termination Currency Equivalent of the Unpaid Amounts owing to Y. If the Early Termination Amount is a positive number, Y will pay it to X; if it is a negative number, X will pay the absolute value of the Early Termination Amount to Y.

(3) *Mid-Market Events*. If that Termination Event is an Illegality or a Force Majeure Event, then the Early Termination Amount will be determined in accordance with clause (1) or (2) above, as appropriate, except that, for the purpose of determining a Close-out Amount or Close-out Amounts, the Determining Party will:—

(A) if obtaining quotations from one or more third parties (or from any of the Determining Party's Affiliates), ask each third party or Affiliate (I) not to take account of the current creditworthiness of the Determining Party or any existing Credit Support Document and (II) to provide mid-market quotations; and

(B) in any other case, use mid-market values without regard to the creditworthiness of the Determining Party.

(iii) *Adjustment for Bankruptcy*. In circumstances where an Early Termination Date occurs because Automatic Early Termination applies in respect of a party, Early Termination Amount will be subject to such adjustments as are appropriate and permitted by applicable law to reflect any payments or deliveries made by one party to the other under this Agreement (and retained by such other party) during the period from the relevant Early Termination Date to the date for payment determined under Section 6(d)(ii).

(iv) *Adjustment for Illegality or Force Majeure Event*. The failure by a party or any Credit Support Provider of such party to pay, when due, any Early Termination Amount will not constitute an Event of Default under Section 5(a)(i) or 5(a)(iii)(I) if such failure is due to the occurrence of an event or circumstance which would, if it occurred with respect to payment, delivery or compliance related to a Transaction, constitute or give rise to an Illegality or a Force Majeure Event. Such amount will (1) accrue interest and otherwise be treated as an Unpaid Amount owing to the other party if subsequently an Early Termination Date results from an Event of Default, a Credit Event Upon Merger or an Additional Termination Event in respect of which all outstanding Transactions are Affected Transactions and (2) otherwise accrue interest in accordance with Section 9(h)(ii)(2).

(v) *Pre-Estimate*. The parties agree that an amount recoverable under this Section 6(e) is a reasonable pre-estimate of loss and not a penalty. Such amount is payable for the loss of bargain and the loss of protection against future risks, and, except as otherwise provided in this Agreement, neither party will be entitled to recover any additional damages as a consequence of the termination of the Terminated Transactions.

(f) *Set-Off* Any Early Termination Amount payable to one party (the "Payee") by the other party (the "Payer"), in circumstances where there is a Defaulting Party or where there is one Affected Party in the case where either a Credit Event Upon Merger has occurred or any other Termination Event in respect of which all outstanding Transactions are Affected Transactions has occurred, will, at the option of the Non-defaulting Party or the Non-affected Party, as the case may be ("X") (and without prior notice to the Defaulting Party or the Affected Party, as the case may be), be reduced by its set-off against any other amounts ("Other Amounts") payable by the Payee to the Payer (whether or not arising under this Agreement, matured or contingent and irrespective of the currency, place of payment or place of booking of the obligation). To the extent that any Other Amounts are so set off, those Other Amounts will be discharged promptly and in all respects. X will give notice to the other party of any set-off effected under this Section 6(f).

For this purpose, either the Early Termination Amount or the Other Amounts (or the relevant portion of such amounts) may be converted by X into the currency in which the other is denominated at the rate of exchange at which such party would be able, in good faith and using commercially reasonable procedures, to purchase the relevant amount of such currency.

If an obligation is unascertained, X may in good faith estimate that obligation and set off in respect of the estimate, subject to the relevant party accounting to the other when the obligation is ascertained.

Nothing in this Section 6(f) will be effective to create a charge or other security interest. This Section 6(f) will be without prejudice and in addition to any right of set-off, offset, combination of accounts, lien, right of retention or withholding or similar right or requirement to which any party is at any time otherwise entitled or subject (whether by operation of law, contract or otherwise).

## 7. Transfer

Subject to Section 6(b)(ii) and to the extent permitted by applicable law, neither this Agreement nor any interest or obligation in or under this Agreement may be transferred (whether by way of security or otherwise) by either party without the prior written consent of the other party, except that:—

- (a) a party may make such a transfer of this Agreement pursuant to a consolidation or amalgamation with, or merger with or into, or transfer of all or substantially all its assets to, another entity (but without prejudice to any other right or remedy under this Agreement); and
- (b) a party may make such a transfer of all or any part of its interest in any Early Termination Amount payable to it by a Defaulting Party, together with any amounts payable on or with respect to that interest and any other rights associated with that interest pursuant to Sections 8, 9(h) and 11.

Any purported transfer that is not in compliance with this Section 7 will be void.

## 8. Contractual Currency

(a) **Payment in the Contractual Currency.** Each payment under this Agreement will be made in the relevant currency specified in this Agreement for that payment (the “Contractual Currency”). To the extent permitted by applicable law, any obligation to make payments under this Agreement in the Contractual Currency will not be discharged or satisfied by any tender in any currency other than the Contractual Currency, except to the extent such tender results in the actual receipt by the party to which payment is owed, acting in good faith and using commercially reasonable procedures in converting the currency so tendered into the Contractual Currency, of the full amount in the Contractual Currency of all amounts payable in respect of this Agreement. If for any reason the amount in the Contractual Currency so received falls short of the amount in the Contractual Currency payable in respect of this Agreement, the party required to make the payment will, to the extent permitted by applicable law, immediately pay such additional amount in the Contractual Currency as may be necessary to compensate for the shortfall. If for any reason the amount in the Contractual Currency so received exceeds the amount in the Contractual Currency payable in respect of this Agreement, the party receiving the payment will refund promptly the amount of such excess.

(b) **Judgments.** To the extent permitted by applicable law, if any judgment or order expressed in a currency other than the Contractual Currency is rendered (i) for the payment of any amount owing in respect of this Agreement, (ii) for the payment of any amount relating to any early termination in respect of this Agreement or (iii) in respect of a judgment or order of another court for the payment of any amount described in clause (i) or (ii) above, the party seeking recovery, after recovery in full of the aggregate amount to which such party is entitled pursuant to the judgment or order, will be entitled to receive immediately from the other party the amount of any shortfall of the Contractual Currency received by such party as a consequence of sums paid in such other currency and will refund promptly to the other party any excess of the Contractual Currency received by such party as a consequence of sums paid in such other currency if such shortfall or such excess arises or results from any variation between the rate of exchange at which the Contractual Currency is converted into the currency of the judgment or order for the purpose of such judgment or order and the rate of exchange at which such party is able, acting in good faith and using commercially reasonable procedures in converting the currency received into the Contractual Currency, to purchase the Contractual Currency with the amount of the currency of the judgment or order actually received by such party.

(c) **Separate Indemnities.** To the extent permitted by applicable law, the indemnities in this Section 8 constitute separate and independent obligations from the other obligations in this Agreement, will be enforceable as separate and independent causes of action, will apply notwithstanding any indulgence granted by the party to which any payment is owed and will not be affected by judgment being obtained or claim or proof being made for any other sums payable in respect of this Agreement.

(d) **Evidence of Loss.** For the purpose of this Section 8, it will be sufficient for a party to demonstrate that it would have suffered a loss had an actual exchange or purchase been made.

## 9. Miscellaneous

(a) **Entire Agreement.** This Agreement constitutes the entire agreement and understanding of the parties with respect to its subject matter. Each of the parties acknowledges that in entering into this Agreement it has not relied on any oral or written representation, warranty or other assurance (except as provided for or referred to in this Agreement) and waives all rights and remedies which might otherwise be available to it in respect thereof, except that nothing in this Agreement will limit or exclude any liability of a party for fraud.

(b) **Amendments.** An amendment, modification or waiver in respect of this Agreement will only be effective if in writing (including a writing evidenced by a facsimile transmission) and executed by each of the parties or confirmed by an exchange of telexes or by an exchange of electronic messages on an electronic messaging system.

(c) **Survival of Obligations.** Without prejudice to Sections 2(a)(iii) and 6(c)(ii), the obligations of the parties under this Agreement will survive the termination of any Transaction.

(d) **Remedies Cumulative.** Except as provided in this Agreement, the rights, powers, remedies and privileges provided in this Agreement are cumulative and not exclusive of any rights, powers, remedies and privileges provided by law.

### (e) Counterparts and Confirmations.

(i) This Agreement (and each amendment, modification and waiver in respect of it) may be executed and delivered in counterparts (including by facsimile transmission and by electronic messaging system), each of which will be deemed an original.

(ii) The parties intend that they are legally bound by the terms of each Transaction from the moment they agree to those terms (whether orally or otherwise). A Confirmation will be entered into as soon as practicable and may be executed and delivered in counterparts (including by facsimile transmission) or be created by an exchange of telexes, by an exchange of electronic messages on an electronic messaging system or by an exchange of e-mails, which in each case will be sufficient for all purposes to evidence a binding supplement to this Agreement. The parties will specify therein or through another effective means that any such counterpart, telex, electronic message or e-mail constitutes a Confirmation.

(f) **No Waiver of Rights.** A failure or delay in exercising any right, power or privilege in respect of this Agreement will not be presumed to operate as a waiver, and a single or partial exercise of any right, power or privilege will not be presumed to preclude any subsequent or further exercise, of that right, power or privilege or the exercise of any other right, power or privilege

(g) **Headings.** The headings used in this Agreement are for convenience of reference only and are not to affect the construction of or to be taken into consideration in interpreting this Agreement.

(h) **Interest and Compensation.**

(i) **Prior to Early Termination.** Prior to the occurrence or effective designation of an Early Termination Date in respect of the relevant Transaction:—

(1) *Interest on Defaulted Payments.* If a party defaults in the performance of any payment obligation, it will, to the extent permitted by applicable law and subject to Section 6(c), pay interest (before as well as after judgment) on the overdue amount to the other party on demand in the same currency as the overdue amount, for the period from (and including) the original due date for payment to (but excluding) the date of actual payment (and excluding any period in respect of which interest or compensation in respect of the overdue amount is due pursuant to clause (3)(B) or (C) below), at the Default Rate.

(2) *Compensation for Defaulted Deliveries.* If a party defaults in the performance of any obligation required to be settled by delivery, it will on demand (A) compensate the other party to the extent provided for in the relevant Confirmation or elsewhere in this Agreement and (B) unless otherwise provided in the relevant Confirmation or elsewhere in this Agreement, to the extent permitted by applicable law and subject to Section 6(c), pay to the other party interest (before as well as after judgment) on an amount equal to the fair market value of that which was required to be delivered in the same currency as that amount, for the period from (and including) the originally scheduled date for delivery to (but excluding) the date of actual delivery (and excluding any period in respect of which interest or compensation in respect of that amount is due pursuant to clause (4) below), at the Default Rate. The fair market value of any obligation referred to above will be determined as of the originally scheduled date for delivery, in good faith and using commercially reasonable procedures, by the party that was entitled to take delivery.

(3) *Interest on Deferred Payments.* If:—

(A) a party does not pay any amount that, but for Section 2(a)(iii), would have been payable, it will, to the extent permitted by applicable law and subject to Section 6(c) and clauses (B) and (C) below, pay interest (before as well as after judgment) on that amount to the other party on demand (after such amount becomes payable) in the same currency as that amount, for the period from (and including) the date the amount would, but for Section 2(a)(iii), have been payable to (but excluding) the date the amount actually becomes payable, at the Applicable Deferral Rate;

(B) a payment is deferred pursuant to Section 5(d), the party which would otherwise have been required to make that payment will, to the extent permitted by applicable law, subject to Section 6(c) and for so long as no Event of Default or Potential Event of Default with respect to that party has occurred and is continuing, pay interest (before as well as after judgment) on the amount of the deferred payment to the other party on demand (after such amount becomes payable) in the same currency as the deferred payment, for the period from (and including) the date the amount would, but for Section 5(d), have been payable to (but excluding) the earlier of the date the payment is no longer deferred pursuant to Section 5(d) and the date during the deferral period upon which an Event of Default or Potential Event of Default with respect to that party occurs, at the Applicable Deferral Rate; or

(C) a party fails to make any payment due to the occurrence of an Illegality or a Force Majeure Event (after giving effect to any deferral period contemplated by clause (B) above), it will, to the extent permitted by applicable law, subject to Section 6(c) and for so long as the event or circumstance giving rise to that Illegality or Force Majeure Event

continues and no Event of Default or Potential Event of Default with respect to that party has occurred and is continuing, pay interest (before as well as after judgment) on the overdue amount to the other party on demand in the same currency as the overdue amount, for the period from (and including) the date the party fails to make the payment due to the occurrence of the relevant Illegality or Force Majeure Event (or, if later, the date the payment is no longer deferred pursuant to Section 5(d)) to (but excluding) the earlier of the date the event or circumstance giving rise to that Illegality or Force Majeure Event ceases to exist and the date during the period upon which an Event of Default or Potential Event of Default with respect to that party occurs (and excluding any period in respect of which interest or compensation in respect of the overdue amount is due pursuant to clause (B) above), at the Applicable Deferral Rate.

(4) *Compensation for Deferred Deliveries.* If:—

- (A) a party does not perform any obligation that, but for Section 2(a)(iii), would have been required to be settled by delivery;
- (B) a delivery is deferred pursuant to Section 5(d); or
- (C) a party fails to make a delivery due to the occurrence of an Illegality or a Force Majeure Event at a time when any applicable Waiting Period has expired,

the party required (or that would otherwise have been required) to make the delivery will, to the extent permitted by applicable law and subject to Section 6(c), compensate and pay interest to the other party on demand (after, in the case of clauses (A) and (B) above, such delivery is required) if and to the extent provided for in the relevant Confirmation or elsewhere in this Agreement.

(ii) **Early Termination.** Upon the occurrence or effective designation of an Early Termination Date in respect of a Transaction:—

(1) *Unpaid Amounts.* For the purpose of determining an Unpaid Amount in respect of the relevant Transaction, and to the extent permitted by applicable law, interest will accrue on the amount of any payment obligation or the amount equal to the fair market value of any obligation required to be settled by delivery included in such determination in the same currency as that amount, for the period from (and including) the date the relevant obligation was (or would have been but for Section 2(a)(iii) or 5(d)) required to have been performed to (but excluding) the relevant Early Termination Date, at the Applicable Close-out Rate.

(2) *Interest on Early Termination Amounts.* If an Early Termination Amount is due in respect of such Early Termination Date, that amount will, to the extent permitted by applicable law, be paid together with interest (before as well as after judgment) on that amount in the Termination Currency, for the period from (and including) such Early Termination Date to (but excluding) the date the amount is paid, at the Applicable Close-out Rate.

(iii) **Interest Calculation.** Any interest pursuant to this Section 9(h) will be calculated on the basis of daily compounding and the actual number of days elapsed.

**10. Offices; Multibranch Parties**

(a) If Section 10(a) is specified in the Schedule as applying, each party that enters into a Transaction through an Office other than its head or home office represents to and agrees with the other party that, notwithstanding the place of booking or its jurisdiction of incorporation or organization, its obligations are the same in terms of recourse against it as if it had entered into the Transaction through its head or home office, except that a party will not have recourse to the head or home office of the other party in respect of any payment or delivery deferred pursuant to Section 5(d) for so long as the payment or delivery is so deferred. This representation and agreement will be deemed to be repeated by each party on each date on which the parties enter into a Transaction.

(b) If a party is specified as a Multibranch Party in the Schedule, such party may, subject to clause (c) below, enter into a Transaction through, book a Transaction in and make and receive payments and deliveries with respect to a Transaction through any Office listed in respect of that party in the Schedule (but not any other Office unless otherwise agreed by the parties in writing).

(c) The Office through which a party enters into a Transaction will be the Office specified for that party in the relevant Confirmation or as otherwise agreed by the parties in writing, and, if an Office for that party is not specified in the Confirmation or otherwise agreed by the parties in writing, its head or home office. Unless the parties otherwise agree in writing, the Office through which a party enters into a Transaction will also be the Office in which it books the Transaction and the Office through which it makes and receives payments and deliveries with respect to the Transaction. Subject to Section 6(b)(ii), neither party may change the Office in which it books the Transaction or the Office through which it makes and receives payments or deliveries with respect to a Transaction without the prior written consent of the other party.

**11. Expenses**

A Defaulting Party will on demand indemnify and hold harmless the other party for and against all reasonable out-of-pocket expenses, including legal fees, execution fees and Stamp Tax, incurred by such other party by reason of the enforcement and protection of its rights under this Agreement or any Credit Support Document to which the Defaulting Party is a party or by reason of the early termination of any Transaction, including, but not limited to, costs of collection.

**12. Notices**

(a) **Effectiveness.** Any notice or other communication in respect of this Agreement may be given in any manner described below (except that a notice or other communication under Section 5 or 6 may not be given by electronic messaging system or e-mail) to the address or number or in accordance with the electronic messaging system or e-mail details provided (see the Schedule) and will be deemed effective as indicated:—

- (i) if in writing and delivered in person or by courier, on the date it is delivered;
- (ii) if sent by telex, on the date the recipient's answerback is received;
- (iii) if sent by facsimile transmission, on the date it is received by a responsible employee of the recipient in legible form (it being agreed that the burden of proving receipt will be on the sender and will not be met by a transmission report generated by the sender's facsimile machine);
- (iv) if sent by certified or registered mail (airmail, if overseas) or the equivalent (return receipt requested), on the date it is delivered or its delivery is attempted;
- (v) if sent by electronic messaging system, on the date it is received; or
- (vi) if sent by e-mail, on the date it is delivered,

unless the date of that delivery (or attempted delivery) or that receipt, as applicable, is not a Local Business Day or that communication is delivered (or attempted) or received, as applicable, after the close of business on a Local Business Day, in which case that communication will be deemed given and effective on the first following day that is a Local Business Day.

(b) **Change of Details.** Either party may by notice to the other change the address, telex or facsimile number or electronic messaging system or e-mail details at which notices or other communications are to be given to it.

### 13. Governing Law and Jurisdiction

(a) **Governing Law.** This Agreement will be governed by and construed in accordance with the law specified in the Schedule.

(b) **Jurisdiction.** With respect to any suit, action or proceedings relating to any dispute arising out of or in connection with this Agreement (“Proceedings”), each party irrevocably:—

(i) submits:—

(1) if this Agreement is expressed to be governed by English law, to (A) the non-exclusive jurisdiction of the English courts if the Proceedings do not involve a Convention Court and (B) the exclusive jurisdiction of the English courts if the Proceedings do involve a Convention Court: or

(2) if this Agreement is expressed to be governed by the laws of the State of New York, to the non-exclusive jurisdiction of the courts of the State of New York and the United States District Court located in the Borough of Manhattan in New York City;

(ii) waives any objection which it may have at any time to the laying of venue of any Proceedings brought in any such court, waives any claim that such Proceedings have been brought in an inconvenient forum and further waives the right to object, with respect to such Proceedings, that such court does not have any jurisdiction over such party; and

(iii) agrees, to the extent permitted by applicable law, that the bringing of Proceedings in any one or more jurisdictions will not preclude the bringing of Proceedings in any other jurisdiction.

(c) **Service of Process.** Each party irrevocably appoints the Process Agent, if any, specified opposite its name in the Schedule to receive, for it and on its behalf, service of process in any Proceedings. If for any reason any party’s Process Agent is unable to act as such, such party will promptly notify the other party and within 30 days appoint a substitute process agent acceptable to the other party. The parties irrevocably consent to service of process given in the manner provided for notices in Section 12(a)(i), 12(a)(iii) or 12(a)(iv). Nothing in this Agreement will affect the right of either party to serve process in any other manner permitted by applicable law.

(d) **Waiver of Immunities.** Each party irrevocably waives, to the extent permitted by applicable law, with respect to itself and its revenues and assets (irrespective of their use or intended use), all immunity on the grounds of sovereignty or other similar grounds from (i) suit, (ii) jurisdiction of any court, (iii) relief by way of injunction or order for specific performance or recovery of property, (iv) attachment of its assets (whether before or after judgment) and (v) execution or enforcement of any judgment to which it or its revenues or assets might otherwise be entitled in any Proceedings in the courts of any jurisdiction and irrevocably agrees, to the extent permitted by applicable law, that it will not claim any such immunity in any Proceedings.



#### 14. Definitions

As used in this Agreement:—

“**Additional Representation**” has the meaning specified in Section 3.

“**Additional Termination Event**” has the meaning specified in Section 5(b).

“**Affected Party**” has the meaning specified in Section 5(b).

“**Affected Transactions**” means (a) with respect to any Termination Event consisting of an Illegality, Force Majeure Event, Tax Event or Tax Event Upon Merger, all Transactions affected by the occurrence of such Termination Event (which, in the case of an Illegality under Section 5(b)(i)(2) or a Force Majeure Event under Section 5(b)(ii)(2), means all Transactions unless the relevant Credit Support Document references only certain Transactions, in which case those Transactions and, if the relevant Credit Support Document constitutes a Confirmation for a Transaction, that Transaction) and (b) with respect to any other Termination Event, all Transactions.

“**Affiliate**” means, subject to the Schedule, in relation to any person, any entity controlled, directly or indirectly, by the person, any entity that controls, directly or indirectly, the person or any entity directly or indirectly under common control with the person. For this purpose, “control” of any entity or person means ownership of a majority of the voting power of the entity or person.

“**Agreement**” has the meaning specified in Section 1(c).

“**Applicable Close-out Rate**” means:—

(a) in respect of the determination of an Unpaid Amount:—

- (i) in respect of obligations payable or deliverable (or which would have been but for Section 2(a)(iii)) by a Defaulting Party, the Default Rate;
- (ii) in respect of obligations payable or deliverable (or which would have been but for Section 2(a)(iii)) by a Non-defaulting Party, the Non-default Rate;
- (iii) in respect of obligations deferred pursuant to Section 5(d), if there is no Defaulting Party and for so long as the deferral period continues, the Applicable Deferral Rate; and
- (iv) in all other cases following the occurrence of a Termination Event (except where interest accrues pursuant to clause (iii) above), the Applicable Deferral Rate; and

(b) in respect of an Early Termination Amount:—

- (i) for the period from (and including) the relevant Early Termination Date to (but excluding) the date (determined in accordance with Section 6(d)(ii)) on which that amount is payable:—
  - (1) if the Early Termination Amount is payable by a Defaulting Party, the Default Rate;
  - (2) if the Early Termination Amount is payable by a Non-defaulting Party, the Non-default Rate; and
  - (3) in all other cases, the Applicable Deferral Rate; and

(ii) for the period from (and including) the date (determined in accordance with Section 6(d)(ii)) on which that amount is payable to (but excluding) the date of actual payment:—

- (1) if a party fails to pay the Early Termination Amount due to the occurrence of an event or circumstance which would, if it occurred with respect to a payment or delivery under a Transaction, constitute or give rise to an Illegality or a Force Majeure Event, and for so long as the Early Termination Amount remains unpaid due to the continuing existence of such event or circumstance, the Applicable Deferral Rate;
- (2) if the Early Termination Amount is payable by a Defaulting Party (but excluding any period in respect of which clause ( 1) above applies), the Default Rate;
- (3) if the Early Termination Amount is payable by a Non-defaulting Party (but excluding any period in respect of which clause (1) above applies), the Non-default Rate; and
- (4) in all other cases, the Termination Rate.

“**Applicable Deferral Rate**” means:—

- (a) for the purpose of Section 9(h)(i)(3)(A), the rate certified by the relevant payer to be a rate offered to the payer by a major bank in a relevant interbank market for overnight deposits in the applicable currency, such bank to be selected in good faith by the payer for the purpose of obtaining a representative rate that will reasonably reflect conditions prevailing at the time in that relevant market;
- (b) for purposes of Section 9(h)(i)(3)(B) and clause (a)(iii) of the definition of Applicable Close-out Rate, the rate certified by the relevant payer to be a rate offered to prime banks by a major bank in a relevant interbank market for overnight deposits in the applicable currency, such bank to be selected in good faith by the payer after consultation with the other party, if practicable, for the purpose of obtaining a representative rate that will reasonably reflect conditions prevailing at the time in that relevant market; and
- (c) for purposes of Section 9(h)(i)(3)(C) and clauses (a)(iv), (b)(i)(3) and (b)(ii)(1) of the definition of Applicable Close-out Rate, a rate equal to the arithmetic mean of the rate determined pursuant to clause (a) above and a rate per annum equal to the cost (without proof or evidence of any actual cost) to the relevant payee (as certified by it) if it were to fund or of funding the relevant amount.

“**Automatic Early Termination**” has the meaning specified in Section 6(a).

“**Burdened Party**” has the meaning specified in Section 5(b)(iv).

“**Change in Tax Law**” means the enactment, promulgation, execution or ratification of, or any change in or amendment to, any law (or in the application or official interpretation of any law) that occurs after the parties enter into the relevant Transaction.

“**Close-out Amount**” means, with respect to each Terminated Transaction or each group of Terminated Transactions and a Determining Party, the amount of the losses or costs of the Determining Party that are or would be incurred under then prevailing circumstances (expressed as a positive number) or gains of the Determining Party that are or would be realized under then prevailing circumstances (expressed as a negative number) in replacing, or in providing for the Determining Party the economic equivalent of, (a) the material terms of that Terminated Transaction or group of Terminated Transactions, including the payments and deliveries by the parties under Section 2(a)(i) in respect of that Terminated Transaction or group of Terminated Transactions that would, but for the occurrence of the relevant Early Termination Date, have been required after that date (assuming satisfaction of the conditions precedent in Section 2(a)(iii)) and (b) the option rights of the parties in respect of that Terminated Transaction or group of Terminated Transactions.

Any Close-out Amount will be determined by the Determining Party (or its agent), which will act in good faith and use commercially reasonable procedures in order to produce a commercially reasonable result. The Determining Party may determine a Close-out Amount for any group of Terminated Transactions or any individual Terminated Transaction but, in the aggregate, for not less than all Terminated Transactions. Each Close-out Amount will be determined as of the Early Termination Date or, if that would not be commercially reasonable, as of the date or dates following the Early Termination Date as would be commercially reasonable.

Unpaid Amounts in respect of a Terminated Transaction or group of Terminated Transactions and legal fees and out-of-pocket expenses referred to in Section 11 are to be excluded in all determinations of Close-out Amounts.

In determining a Close-out Amount, the Determining Party may consider any relevant information, including, without limitation, one or more of the following types of information:—

- (i) quotations (either firm or indicative) for replacement transactions supplied by one or more third parties that may take into account the creditworthiness of the Determining Party at the time the quotation is provided and the terms of any relevant documentation, including credit support documentation, between the Determining Party and the third party providing the quotation;
- (ii) information consisting of relevant market data in the relevant market supplied by one or more third parties including, without limitation, relevant rates, prices, yields, yield curves, volatilities, spreads, correlations or other relevant market data in the relevant market; or
- (iii) information of the types described in clause (i) or (ii) above from internal sources (including any of the Determining Party's Affiliates) if that information is of the same type used by the Determining Party in the regular course of its business for the valuation of similar transactions.

The Determining Party will consider, taking into account the standards and procedures described in this definition, quotations pursuant to clause (i) above or relevant market data pursuant to clause (ii) above unless the Determining Party reasonably believes in good faith that such quotations or relevant market data are not readily available or would produce a result that would not satisfy those standards. When considering information described in clause (i), (ii) or (iii) above, the Determining Party may include costs of funding, to the extent costs of funding are not and would not be a component of the other information being utilized. Third parties supplying quotations pursuant to clause (i) above or market data pursuant to clause (ii) above may include, without limitation, dealers in the relevant markets, end-users of the relevant product, information vendors, brokers and other sources of market information.

Without duplication of amounts calculated based on information described in clause (i), (ii) or (iii) above, or other relevant information, and when it is commercially reasonable to do so, the Determining Party may in addition consider in calculating a Close-out Amount any loss or cost incurred in connection with its terminating, liquidating or re-establishing any hedge related to a Terminated Transaction or group of Terminated Transactions (or any gain resulting from any of them).

Commercially reasonable procedures used in determining a Close-out Amount may include the following:—

- (1) application to relevant market data from third parties pursuant to clause (ii) above or information from internal sources pursuant to clause (iii) above of pricing or other valuation models that are, at the time of the determination of the Close-out Amount, used by the Determining Party in the regular course of its business in pricing or valuing transactions between the Determining Party and unrelated third parties that are similar to the Terminated Transaction or group of Terminated Transactions; and

(2) application of different valuation methods to Terminated Transactions or groups of Terminated Transactions depending on the type, complexity, size or number of the Terminated Transactions or group of Terminated Transactions.

“**Confirmation**” has the meaning specified in the preamble.

“**consent**” includes a consent, approval, action, authorization, exemption, notice, filing, registration or exchange control consent.

“**Contractual Currency**” has the meaning specified in Section 8(a).

“**Convention Court**” means any court which is bound to apply to the Proceedings either Article 17 of the 1968 Brussels Convention on Jurisdiction and the Enforcement of Judgments in Civil and Commercial Matters or Article 17 of the 1988 Lugano Convention on Jurisdiction and the Enforcement of Judgments in Civil and Commercial Matters.

“**Credit Event Upon Merger**” has the meaning specified in Section 5(b).

“**Credit Support Document**” means any agreement or instrument that is specified as such in this Agreement.

“**Credit Support Provider**” has the meaning specified in the Schedule.

“**Cross-Default**” means the event specified in Section 5(a)(vi).

“**Default Rate**” means a rate per annum equal to the cost (without proof or evidence of any actual cost) to the relevant payee (as certified by it) if it were to fund or of funding the relevant amount plus 1% per annum.

“**Defaulting Party**” has the meaning specified in Section 6(a).

“**Designated Event**” has the meaning specified in Section 5(b)(v).

“**Determining Party**” means the party determining a Close-out Amount.

“**Early Termination Amount**” has the meaning specified in Section 6(e).

“**Early Termination Date**” means the date determined in accordance with Section 6(a) or 6(b)(iv).

“**electronic messages**” does not include e-mails but does include documents expressed in markup languages, and “**electronic messaging system**” will be construed accordingly.

“**English law**” means the law of England and Wales, and “**English**” will be construed accordingly.

“**Event of Default**” has the meaning specified in Section 5(a) and, if applicable, in the Schedule.

“**Force Majeure Event**” has the meaning specified in Section 5(b).

“**General Business Day**” means a day on which commercial banks are open for general business (including dealings in foreign exchange and foreign currency deposits).

“**Illegality**” has the meaning specified in Section 5(b).

“**Indemnifiable Tax**” means any Tax other than a Tax that would not be imposed in respect of a payment under this Agreement but for a present or former connection between the jurisdiction of the government or taxation authority imposing such Tax and the recipient of such payment or a person related to such recipient (including, without limitation, a connection arising from such recipient or related person being or having been a citizen or resident of such jurisdiction, or being or having been organised, present or engaged in a trade or business in such jurisdiction, or having or having had a permanent establishment or fixed place of business in such jurisdiction, but excluding a connection arising solely from such recipient or related person having executed, delivered, performed its obligations or received a payment under, or enforced, this Agreement or a Credit Support Document).

“**law**” includes any treaty, law, rule or regulation (as modified, in the case of tax matters, by the practice of any relevant governmental revenue authority), and “**unlawful**” will be construed accordingly.

“**Local Business Day**” means (a) in relation to any obligation under Section 2(a)(i), a General Business Day in the place or places specified in the relevant Confirmation and a day on which a relevant settlement system is open or operating as specified in the relevant Confirmation or, if a place or a settlement system is not so specified, as otherwise agreed by the parties in writing or determined pursuant to provisions contained, or incorporated by reference, in this Agreement, (b) for the purpose of determining when a Waiting Period expires, a General Business Day in the place where the event or circumstance that constitutes or gives rise to the Illegality or Force Majeure Event, as the case may be, occurs, (c) in relation to any other payment, a General Business Day in the place where the relevant account is located and, if different, in the principal financial centre, if any, of the currency of such payment and, if that currency does not have a single recognized principal financial centre, a day on which the settlement system necessary to accomplish such payment is open, (d) in relation to any notice or other communication, including notice contemplated under Section 5(a)(i), a General Business Day (or a day that would have been a General Business Day but for the occurrence of an event or circumstance which would, if it occurred with respect to payment, delivery or compliance related to a Transaction, constitute or give rise to an Illegality or a Force Majeure Event) in the place specified in the address for notice provided by the recipient and, in the case of a notice contemplated by Section 2(b), in the place where the relevant new account is to be located and (e) in relation to Section 5(a)(v)(2), a General Business Day in the relevant locations for performance with respect to such Specified Transaction.

“**Local Delivery Day**” means, for purposes of Sections 5(a)(i) and 5(d), a day on which settlement systems necessary to accomplish the relevant delivery are generally open for business so that the delivery is capable of being accomplished in accordance with customary market practice, in the place specified in the relevant Confirmation or, if not so specified, in a location as determined in accordance with customary market practice for the relevant delivery.

“**Master Agreement**” has the meaning specified in the preamble.

“**Merger Without Assumption**” means the event specified in Section 5(a)(viii).

“**Multiple Transaction Payment Netting**” has the meaning specified in Section 2(c).

“**Non-affected Party**” means, so long as there is only one Affected Party, the other party.

“**Non-default Rate**” means the rate certified by the Non-defaulting Party to be a rate offered to the Non-defaulting Party by a major bank in a relevant interbank market for overnight deposits in the applicable currency, such bank to be selected in good faith by the Non-defaulting Party for the purpose of obtaining a representative rate that will reasonably reflect conditions prevailing at the time in that relevant market.

“**Non-defaulting Party**” has the meaning specified in Section 6(a).

“**Office**” means a branch or office of a party, which may be such party’s head or home office.

“**Other Amounts**” has the meaning specified in Section 6(f).

“**Payee**” has the meaning specified in Section 6(f).

“**Payer**” has the meaning specified in Section 6(f).

“**Potential Event of Default**” means any event which, with the giving of notice or the lapse of time or both, would constitute an Event of Default.

“**Proceedings**” has the meaning specified in Section 13(b).

“**Process Agent**” has the meaning specified in the Schedule.

“**rate of exchange**” includes, without limitation, any premiums and costs of exchange payable in connection with the purchase of or conversion into the Contractual Currency.

“**Relevant Jurisdiction**” means, with respect to a party, the jurisdictions (a) in which the party is incorporated, organised, managed and controlled or considered to have its seat, (b) where an Office through which the party is acting for purposes of this Agreement is located, (c) in which the party executes this Agreement and (d) in relation to any payment, from or through which such payment is made.

“**Schedule**” has the meaning specified in the preamble.

“**Scheduled Settlement Date**” means a date on which a payment or delivery is to be made under Section 2(a)(i) with respect to a Transaction.

“**Specified Entity**” has the meaning specified in the Schedule.

“**Specified Indebtedness**” means, subject to the Schedule, any obligation (whether present or future, contingent or otherwise, as principal or surety or otherwise) in respect of borrowed money.

“**Specified Transaction**” means, subject to the Schedule, (a) any transaction (including an agreement with respect to any such transaction) now existing or hereafter entered into between one party to this Agreement (or any Credit Support Provider of such party or any applicable Specified Entity of such party) and the other party to this Agreement (or any Credit Support Provider of such other party or any applicable Specified Entity of such other party) which is not a Transaction under this Agreement but (i) which is a rate swap transaction, swap option, basis swap, forward rate transaction, commodity swap, commodity option, equity or equity index swap, equity or equity index option, bond option, interest rate option, foreign exchange transaction, cap transaction, floor transaction, collar transaction, currency swap transaction, cross-currency rate swap transaction, currency option, credit protection transaction, credit swap, credit default swap, credit default option, total return swap, credit spread transaction, repurchase transaction, reverse repurchase transaction, buy/sell-back transaction, securities lending transaction, weather index transaction or forward purchase or sale of a security, commodity or other financial instrument or interest (including any option with respect to any of these transactions) or (ii) which is a type of transaction that is similar to any transaction referred to in clause (i) above that is currently, or in the future becomes, recurrently entered into in the financial markets (including terms and conditions incorporated by reference in such agreement) and which is a forward, swap, future, option or other derivative on one or more rates, currencies, commodities, equity securities or other equity instruments, debt securities or other debt instruments, economic indices or measures of economic risk or value, or other benchmarks against which payments or deliveries are to be made, (b) any combination of these transactions and (c) any other transaction identified as a Specified Transaction in this Agreement or the relevant confirmation.

“**Stamp Tax**” means any stamp, registration, documentation or similar tax.

“**Stamp Tax Jurisdiction**” has the meaning specified in Section 4(e).

“**Tax**” means any present or future tax, levy, impost, duty, charge, assessment or fee of any nature (including interest, penalties and additions thereto) that is imposed by any government or other taxing authority in respect of any payment under this Agreement other than a stamp, registration, documentation or similar tax.

“**Tax Event**” has the meaning specified in Section 5(b).

“**Tax Event Upon Merger**” has the meaning specified in Section 5(b).

“**Terminated Transactions**” means, with respect to any Early Termination Date, (a) if resulting from an Illegality or a Force Majeure Event, all Affected Transactions specified in the notice given pursuant to Section 6(b)(iv), (b) if resulting from any other Termination Event, all Affected Transactions and (c) if resulting from an Event of Default, all Transactions in effect either immediately before the effectiveness of the notice designating that Early Termination Date or, if Automatic Early Termination applies, immediately before that Early Termination Date.

“**Termination Currency**” means (a) if a Termination Currency is specified in the Schedule and that currency is freely available, that currency, and (b) otherwise, Euro if this Agreement is expressed to be governed by English law or United States Dollars if this Agreement is expressed to be governed by the laws of the State of New York.

“**Termination Currency Equivalent**” means, in respect of any amount denominated in the Termination Currency, such Termination Currency amount and, in respect of any amount denominated in a currency other than the Termination Currency (the “Other Currency”), the amount in the Termination Currency determined by the party making the relevant determination as being required to purchase such amount of such Other Currency as at the relevant Early Termination Date, or, if the relevant Close-out Amount is determined as of a later date, that later date, with the Termination Currency at the rate equal to the spot exchange rate of the foreign exchange agent (selected as provided below) for the purchase of such Other Currency with the Termination Currency at or about 11:00 a.m. (in the city in which such foreign exchange agent is located) on such date as would be customary for the determination of such a rate for the purchase of such Other Currency for value on the relevant Early Termination Date or that later date. The foreign exchange agent will, if only one party is obliged to make a determination under Section 6(e), be selected in good faith by that party and otherwise will be agreed by the parties.

“**Termination Event**” means an Illegality, a Force Majeure Event, a Tax Event, a Tax Event Upon Merger or, if specified to be applicable, a Credit Event Upon Merger or an Additional Termination Event.

“**Termination Rate**” means a rate per annum equal to the arithmetic mean of the cost (without proof or evidence of any actual cost) to each party (as certified by such party) if it were to fund or of funding such amounts.

“**Threshold Amount**” means the amount, if any, specified as such in the Schedule.

“**Transaction**” has the meaning specified in the preamble.

“**Unpaid Amounts**” owing to any party means, with respect to an Early Termination Date, the aggregate of (a) in respect of all Terminated Transactions, the amounts that became payable (or that would have become payable but for Section 2(a)(iii) or due but for Section 5(d)) to such party under Section 2(a)(i) or 2(d)(i)(4) on or prior to such Early Termination Date and which remain unpaid as at such Early Termination Date, (b) in respect of each Terminated Transaction, for each obligation under Section 2(a)(i) which was (or would have been but for Section 2(a)(iii) or 5(d)) required to be settled by delivery to such party on or prior to such Early Termination Date and which has not been so settled as at such Early Termination Date, an amount equal to the fair market value of that which was (or would have been) required to be delivered and (c) if the Early Termination Date results from an Event of Default, a Credit Event Upon Merger or an Additional Termination Event in respect of which all outstanding Transactions are Affected Transactions, any Early Termination Amount due prior to such Early Termination Date and which remains unpaid as of such Early Termination Date, in each case together with any amount of interest accrued or other

compensation in respect of that obligation or deferred obligation, as the case may be, pursuant to Section 9(h)(ii)(1) or (2), as appropriate. The fair market value of any obligation referred to in clause (b) above will be determined as of the originally scheduled date for delivery, in good faith and using commercially reasonable procedures, by the party obliged to make the determination under Section 6(e) or, if each party is so obliged, it will be the average of the Termination Currency Equivalents of the fair market values so determined by both parties.

“*Waiting Period*” means:—

- (a) in respect of an event or circumstance under Section 5(b)(i), other than in the case of Section 5(b)(i)(2) where the relevant payment, delivery or compliance is actually required on the relevant day (in which case no Waiting Period will apply), a period of three Local Business Days (or days that would have been Local Business Days but for the occurrence of that event or circumstance) following the occurrence of that event or circumstance; and
- (b) in respect of an event or circumstance under Section 5(b)(ii), other than in the case of Section 5(b)(ii)(2) where the relevant payment, delivery or compliance is actually required on the relevant day (in which case no Waiting Period will apply), a period of eight Local Business Days (or days that would have been Local Business Days but for the occurrence of that event or circumstance) following the occurrence of that event or circumstance.

IN WITNESS WHEREOF the parties have executed this document on the respective dates specified below with effect from the date specified on the first page of this document.

**MORGAN STANLEY CAPITAL SERVICES LLC**

**MN AIRLINES, LLC**

By: /s/ Charmaine Fearon  
Name: Charmaine Fearon  
Title: Authorized Signatory  
Date:

By: /s/ Dave Davis  
Name: Dave Davis  
Title: EVP + CFO  
Date:





International Swaps Dealers Association, Inc.

**SCHEDULE**  
to the

**2002 MASTER AGREEMENT**

dated as of April 12, 2018

**Between**

**MORGAN STANLEY CAPITAL SERVICES LLC**

*(“Party A”)*

a Delaware limited liability company

**MN AIRLINES, LLC**

*(“Party B”)*

established as a limited liability company  
(d/b/a Sun Country Airlines)  
under the laws of the State of Minnesota

**Part 1. Termination Provisions.**

(a) **“Specified Entity”** means in relation to Party A for the purpose of:

Section 5(a)(v) (Default Under Specified Transaction)	Affiliates
Section 5(a)(vi) (Cross Default)	None Specified
Section 5(a)(vii) (Bankruptcy)	None Specified
Section 5(b)(v) (Credit Event Upon Merger)	None Specified

and in relation to Party B for the purpose of:

Section 5(a)(v) (Default Under Specified Transaction)	None Specified
Section 5(a)(vi) (Cross Default)	None Specified
Section 5(a)(vii) (Bankruptcy)	None Specified
Section 5(b)(v) (Credit Event Upon Merger)	None Specified

- (b) **“Specified Transaction”** has the meaning specified in Section 14 of this Agreement.
- (c) **Cross-Default** applies to Party A and Party B, provided that Section 5(a)(vi) is amended by (i) deleting the words “or becoming capable at such time of being declared”; and (ii) adding the following at the end thereof: “; provided, however, that notwithstanding the foregoing, an Event of Default shall not be deemed to have occurred at any time under either (2) above if at such time the failure to pay referred to in (2) above (i) is a failure to pay caused solely by an error or omission of an administrative or operational nature and funds were available to such party to enable it at the required time to make the relevant payment when due and such relevant payment is made within three Business Days following the discovery of such error or omission and the Defaulting Party had the funds available to prevent the resulting Default or (ii) does not result in the obligations under such Specified Indebtedness becoming due and payable under such agreements or instruments, before it would otherwise have been due and payable.”
- “Specified Indebtedness”** has the meaning specified in Section 14 of this Agreement.
- “Threshold Amount”** means with respect to Party A, an amount equal to USD 10,000,000 (or the equivalent in another currency, currency unit or combination thereof), and with respect to Party B, an amount equal to USD 10,000,000 (or the equivalent in another currency, currency unit or combination thereof).
- (d) **Credit Event Upon Merger** will apply to Party A and will apply to Party B; *provided* that with respect to Party B, any event allowed as of the date hereof by the Asset-Based Revolving Credit Agreement dated as of December 13, 2017 among SCA Acquisition, LLC, Party B, Barclays Bank Plc and the lenders thereunder (the **“Credit Agreement”**), shall not constitute a Credit Event Upon Merger.
- (e) The **Automatic Early Termination** provision of Section 6(a) will not apply to Party A and will not apply to Party B.
- (f) **“Termination Currency”** means United States Dollars (**“USD”**).
- (g) **Additional Termination Event** will not apply.
- (h) **Termination Rights.** Notwithstanding anything to the contrary in this Agreement, the right of a party (the **“Non-Affected Party”**) to designate an Early Termination Date as the result of the occurrence of a Termination Event in respect of which the other party is the Affected Party and the Non-defaulting Party’s right to designate an Early Termination Date as a result of the occurrence and continuance of an Event of Default in respect of which the other party is the Defaulting Party shall lapse if such Early Termination Date does not occur within sixty (60) days after receipt either (i) by the Non-Affected Party of notice from the Affected Party of the occurrence of such Termination Event or by the Non-defaulting Party of notice from the Defaulting Party of the occurrence of the Event of Default, or (ii) by the Affected Party of notice from the Non-Affected Party of the occurrence of such Termination Event or by the Defaulting Party of notice from the Non-Defaulting Party of the occurrence of the Event of Default; provided, however, that this provision (i) does not limit, subject to the foregoing notice provision, the right of the Non-Affected Party to designate an Early Termination Date as the result of the separate occurrence of such Termination Event or the occurrence of any other Termination Event or of the Non-defaulting Party to designate an Early Termination Date as the result of the separate occurrence of such Event of Default or the occurrence of any other Event of Default and (ii) does not limit the right of the Non-Affected Party or the Defaulting Party to designate an Early Termination Date absent such a notice.
- (i) **Bankruptcy.** Section 5(a)(vii) of this Agreement is hereby amended by substituting the words “within 60 days” for the words “within 15 days” where they appear in sub-clauses (4) and (7) thereof.

**Part 2. Tax Representations.**

(a) **Party A and Party B Payer Tax Representations.** For the purpose of Section 3(e) of this Agreement, each of Party A and Party B makes the following representation.

It is not required by any applicable law, as modified by the practice of any relevant governmental revenue authority, of any Relevant Jurisdiction to make any deduction or withholding for or on account of any Tax from any payment (other than interest under Section 9(h) of this Agreement) to be made by it to the other party under this Agreement. In making this representation, it may rely on: (i) the accuracy of any representations made by the other party pursuant to Section 3(f) of this Agreement; (ii) the satisfaction of the agreement contained in Sections 4(a)(i) or 4(a)(iii) of this Agreement and the accuracy and effectiveness of any document provided by the other party pursuant to Sections 4(a)(i) or 4(a)(iii) of this Agreement; and (iii) the satisfaction of the agreement of the other party contained in Section 4(d) of this Agreement, except that it will not be a breach of this representation where reliance is placed on clause (ii) and the other party does not deliver a form or document under Section 4(a)(iii) of this Agreement by reason of material prejudice to its legal or commercial position.

(b) **Party A and Party B Payee Tax Representations.**

(i) For the purpose of Section 3(f) of this Agreement, Party A makes the following representation:

It is a limited liability company duly organized and formed under the laws of the State of Delaware and is a disregarded entity for U.S. federal income tax purposes. Party A's sole member is a corporation duly organized under the laws of the State of Delaware and is an exempt recipient under Section 1.6049-4(c)(1)(ii) of the United States Treasury Regulations.

(ii) For the purpose of Section 3(f) of this Agreement, Party B makes the following representation:

It is a limited liability company organized under the laws of the State of Minnesota and is a disregarded entity for U.S. federal income tax purposes of a limited liability company organized under the laws of the State of Delaware, which has elected to be treated as an association taxable as a corporation for U.S. federal income tax purposes. It is an exempt recipient under Section 1.6049-4(c)(1)(ii) of the United States Treasury Regulations.

**Part 3. Agreement to Deliver Documents.**

For the purpose of Sections 4(a)(i) and (ii) of this Agreement, each party agrees to deliver the following documents, as applicable:

(a) Tax forms, documents or certificates to be delivered are:

Party required to deliver document	Form/Document/ Certificate	Date by which to be delivered
Party A	An executed United States Internal Revenue Service Form W-9 (or any successor thereto).	(i) Upon the execution of this Agreement; and (ii) promptly upon any form (or any successor thereto) previously provided becoming obsolete, incorrect, or expired.
Party B	An executed United States Internal Revenue Service Form W-9 (or any successor thereto).	(i) Upon the execution of this Agreement; and (ii) promptly upon any form (or any successor thereto) previously provided becoming obsolete, incorrect, or expired.

(b) Other documents to be delivered are:

Party required to deliver document	Form/Document/ Certificate	Date by which to be delivered	Covered by Section 3(d) Representation
Each Party	Evidence reasonably satisfactory in form and substance to the other party of (i) the authority of the signatory of the party to execute this Agreement and any Confirmation and (ii) list of the names, true signatures of the signatory of this Agreement or any Confirmation.	Upon execution of this Agreement	Yes
Party A	A copy of the annual report of Morgan Stanley containing audited consolidated financial statements for the most recently ended fiscal year, certified by independent certified public accountants and prepared in accordance with generally accepted accounting principles in the country in which such party is organized; provided however that Party A shall not be required to deliver such annual report if it is publicly available at <a href="http://www.morganstanley.com">www.morganstanley.com</a> , or at <a href="http://www.sec.gov">www.sec.gov</a> .	As soon as reasonably practicable following a the execution of this Agreement, and also within 120 calendar days after the end of each fiscal year while there are any obligations outstanding under this Agreement.	Yes
Party B	A copy of the annual report of Party B containing audited consolidated financial statements for each such fiscal year, certified by independent certified public accountants and prepared in accordance with generally accepted accounting principles in the country in which such party is organized, and any unaudited quarterly financial statements; provided however that Party B shall not be required to deliver such documents if it is publicly available.	As soon as practicable after the execution of this Agreement and also within 120 calendar days after the end of each fiscal year while there are any obligations outstanding under this Agreement.	Yes
Party A and Party B	Such other documents as the other party may reasonably request.	Upon request	No

Part 4. **Miscellaneous.**(a) **Addresses for Notices.** For the purpose of Section 12(a) of this Agreement:

## (i) Address for notices or communications to Party A:

For notices or communications with respect to Sections 5 or 6 only:

c/o MORGAN STANLEY & CO. LLC  
 1585 Broadway  
 New York, New York 10036-8293  
 Attention: Close-out Notices  
*With a mandatory copy to:*  
 Facsimile No.: +1 212 507 4622

For notices or communications with respect to all purposes other than Sections 5 or 6:

c/o MORGAN STANLEY & CO. LLC  
 1585 Broadway  
 New York, New York 10036-8293  
 Attention: Miscellaneous Notices  
 Facsimile No.: +1 212 404 9899

## (ii) Address for notices or communications to Party B:

Dave Davis, EVP & CFO  
 Sun Country Airlines  
 1300 Corporate Center Curve  
 Eagan, MN 55121  
 612-803-6336  
 dave.davis@suncountry.com

With a copy to:

William Marino  
 Apollo Capital Management  
 3 Bryant Park, 40th Floor  
 New York, NY 10036  
 Phone: (212) 822-0808  
 Fax: (646) 607-0630  
 wmarino@apollopl.com

Notwithstanding Section 12(a) of this Agreement, service of legal process documents relating to this Agreement may not be delivered by facsimile.

(b) **Process Agent.** For the purpose of Section 13(c) of this Agreement:

## (i) Party A irrevocably appoints as its Process Agent:

Morgan Stanley & Co. LLC  
 1585 Broadway  
 New York, New York 10036-8293  
 Attention: Chief Legal Officer

## (ii) Party B irrevocably appoints as its Process Agent: None

(c) **Offices.** The provisions of Section 10(a) of this Agreement will apply to Party A and Party B.(d) **Multibranch Party.** For the purpose of Section 10(b) of this Agreement:

Party A is not a Multibranch Party.

Party B is not a Multibranch Party.

- (e) **“Calculation Agent”** means Party A, unless otherwise specified in a Confirmation in relation to the relevant Transaction. If an Event of Default has occurred and is continuing with respect to Party A, Party B shall designate a leading dealer in the relevant market to act as Calculation Agent. Party B shall promptly notify Party A of any objections raised in relation to the calculations and determinations, specifying in reasonable detail (i) its objection, together with supporting calculations, (ii) its proposed calculation and (iii) the amount, if any, which is not in dispute (the **“Undisputed Amount”**). If the parties are unable to expeditiously and in good faith agree on the appropriate calculations or determinations within a commercially reasonable time, which shall not exceed three (3) Business Days (the **“Dispute Notification Deadline”**), each of the parties shall select a leading, independent dealer in the relevant market to act as Calculation Agent with respect to the issue in dispute. In making the calculation, such dealers shall take into consideration the latest available quotation for the relevant Commodity Reference Price, if applicable, and any other information that in good faith it deems relevant. The calculated amount shall be the arithmetic mean of the three calculations by such dealers and the Calculation Agent, which shall be binding and conclusive absent manifest error. Pending the resolution of any dispute hereunder, the Undisputed Amount shall be paid on the scheduled due date. The amount, if any, due as a result of the resolution of a dispute shall be payable on the first Local Business Day after such resolution.

If the independent dealers fail to provide the information necessary for the Calculation Agent to calculate or determine the calculated amount by 4:00 p.m. on the third Local Business Day after the Dispute Notification Deadline, then the calculation by the Calculation Agent shall govern.

The Calculation Agent shall, upon reasonable written request by the other party, provide a written explanation of any calculation, determination, or adjustment made by it including, where applicable, a description of the methodology and the basis for such calculation, determination or adjustment in reasonable detail, provided that the Calculation Agent shall not be obligated to disclose any methodology or basis of calculation, determination or adjustment that is proprietary to it.

- (f) **Credit Support Document.** None
- (g) **Credit Support Provider.** None
- (h) **Governing Law; Jurisdiction.** Sections 13(a) and (b) of the Agreement shall be deleted and replaced with the following:
- “(a) **Governing Law.** This Agreement will be governed by and construed in accordance with the laws of the State of New York (without reference to choice of law doctrine).
- (b) **Jurisdiction.** With respect to any suit, action or proceedings relating to any dispute arising out of or in connection with this Agreement (“Proceedings”), each party:
- (i) irrevocably submits to the exclusive jurisdiction of the courts of the State of New York and the United States District Court located in the Borough of Manhattan in New York City of the State of New York; and
  - (ii) waives any objection which it may have at any time to the laying of venue of any Proceedings brought in any such court, waives any claim that such Proceedings have been brought in an inconvenient forum and further waives the right to object, with respect to such Proceedings, that such court does not have any jurisdiction over such party.”

Nothing in this Agreement shall preclude either party from bringing Proceedings in any other jurisdiction in order to enforce any judgment obtained in any Proceedings referred to in the preceding sentence, nor will the bringing of such enforcement Proceedings in any one or more jurisdictions preclude the bringing of enforcement Proceedings in any other jurisdiction.

- (i) **Waiver of Jury Trial.** EACH PARTY WAIVES, TO THE FULLEST EXTENT PERMITTED BY APPLICABLE LAW, ANY RIGHT IT MAY HAVE TO A TRIAL BY JURY IN RESPECT OF ANY PROCEEDINGS RELATING TO THIS AGREEMENT OR ANY CREDIT SUPPORT DOCUMENT.
- (j) **Netting of Payments.** “Multiple Transaction Payment Netting” will apply for the purpose of Section 2(c) of this Agreement to all Transactions under this Agreement, provided, however, that (i) obligations to make payments pursuant to FX Transactions shall only be netted, satisfied and discharged against obligations to make payments arising out of the same or other FX Transactions and obligations to make payments pursuant to Currency Option Transactions shall only be netted, satisfied and discharged against obligations to make payments arising out of the same or other Currency Option Transactions and (ii) Premiums in respect of Currency Option Transactions shall be netted, satisfied and discharged only against other Premiums in respect of Currency Option Transactions. The Calculation Agent shall notify the parties of the amounts of any such netted payments (which notice may be by telephone).
- (k) **“Affiliate”** has the meaning specified in Section 14 of this Agreement; provided that (i) in relation to Party A excludes Morgan Stanley Derivative Products Inc. and (ii) Party B shall be deemed not to have any Affiliates.
- (l) **Absence of Litigation.** For the purpose of Section 3(c) of this Agreement “Specified Entity” shall mean Affiliates in relation to Party A and Affiliates in relation to Party B.
- (m) **No Agency.** The provisions of Section 3(g) will apply to both parties of this Agreement.
- (n) **Additional Representation** will apply. For the purpose of Section 3 of this Agreement, the following will constitute Additional Representations:
  - (h) **Relationship Between Parties.** Each party will be deemed to represent to the other party on each date on which it enters into a Transaction that (absent a written agreement between the parties that expressly imposes affirmative obligations to the contrary for that Transaction):
    - (i) **Non-Reliance.** It is acting for its own account, and it has made its own independent decisions to enter into that Transaction and as to whether that Transaction is appropriate or proper for it based upon its own judgment and upon advice from such advisers as it has deemed necessary. It is not relying on any communication (written or oral) of the other party as investment advice or as a recommendation to enter into that Transaction, and the other party is not acting with respect to any communication (written or oral) as a “municipal advisor,” as such term is defined in Section 975 of the U.S. Dodd-Frank Wall Street Reform & Consumer Protection Act; it being understood that information and explanations related to the terms and conditions of a Transaction shall not be considered investment advice, advice provided by a municipal advisor or a recommendation to enter into that Transaction. No communication (written or oral) received from the other party shall be deemed to be an assurance or guarantee as to the expected results of that Transaction;
    - (ii) **Assessment and Understanding.** It is capable of assessing the merits of and understanding (on its own behalf or through independent professional advice), and understands and accepts, the terms, conditions and risks of that Transaction. It is also capable of assuming, and assumes, the risks of that Transaction; and
    - (iii) **Status of Parties.** The other party is not acting as a fiduciary for or an adviser to it in respect of that Transaction.
  - (i) **Non-ERISA Representation.** Party B represents (which representations will be deemed to be repeated by it at all times until termination of this Agreement) that it is not (i) an employee benefit plan, as defined in Section 3(3) of the Employee Retirement Income Security Act of 1974, as

amended (“ERISA”), subject to Title I of ERISA (an “ERISA Plan”) or a plan subject to Section 4975 of the Internal Revenue Code of 1986, as amended, or subject to any other statute, regulation, procedure or restriction that is materially similar to Section 406 of ERISA or Section 4975 of the Code (together with ERISA Plans, “Plans”), (ii) a person any of the assets of whom constitute assets of a Plan, or (iii) in connection with any Transaction under this Agreement, a person acting on behalf of a Plan, or using the assets of a Plan. It will provide notice to the other party in the event that it is aware that it is in breach of any aspect of this representation or is aware that with the passing of time, giving of notice or expiry of any applicable grace period it will breach this representation.

- (j) **Eligible Contract Participant.** Each party represents (which representations will be deemed to be repeated by it at all times until termination of this Agreement) that it and its Credit Support Provider, if applicable, is an "eligible contract participant" as defined in Section 1a(18) of the Commodity Exchange Act, as amended.
- (k) **Non-Financial End User.** Party B represents, now and upon the execution of each new Transaction, that it is a non-financial end user, as defined in the Commodity Futures Trading Commission’s Margin Requirements for Uncleared Swaps for Swap Dealers and Major Swap Participants final rule.
- (o) **Recording of Conversations.** Each party (i) consents to the recording of telephone conversations between the trading, marketing and other relevant personnel of the parties in connection with this Agreement or any potential Transaction, (ii) agrees to obtain any necessary consent of, and give any necessary notice of such recording to, its relevant personnel and (iii) agrees, to the extent permitted by applicable law, that recordings may be submitted in evidence in any Proceedings.

#### Part 5. Other Provisions.

- (a) **Transfer.** Section 7 of this Agreement is hereby amended by adding the words “(which consent shall not be unreasonably withheld, conditioned or delayed)” following the words “of the other party” in line three thereof.

Notwithstanding Section 7, Party A may transfer this Agreement and all of its interests or obligations in or under this Agreement to any of its Affiliates, provided that:

- (i) *Credit Worthiness:* the transferee (or its Credit Support Provider, which will guarantee the transferee’s obligations under the Agreement) has substantially the same credit worthiness as Party A;
- (ii) *No Gross-up:* Party B will not, as a result of such transfer, be required on the next succeeding Scheduled Payment Date to pay to the transferee an amount in respect of an Indemnifiable Tax under Section 2(d)(i)(4) greater than the amount in respect of which Party B would have been required to pay to Party A in the absence of such transfer;
- (iii) *No Withholding:* The transferee will not, as a result of such transfer, be required on the next succeeding Scheduled Payment Date to withhold or deduct on account of a Tax under Section 2(d)(i) an amount in excess of that which Party A would have been required to so withhold or deduct on the next succeeding Scheduled Payment Date in the absence of such transfer unless the transferee would be required to make additional payments pursuant to Section 2(d)(i)(4) corresponding to such excess;
- (iv) *No Event of Default, etc.:* no Event of Default or Termination Event will occur as a result of such transfer; and
- (v) *Not Unlawful, etc.:* as a result of such transfer, it will not become unlawful for either party to perform any obligation under this Agreement, nor will it render either party not in compliance with any relevant rule or regulation by which it is bound in performing any obligation.



(vi) *Dealers*: both Party A and the Affiliate transferee are “swap dealers” within the meaning of the Commodity Exchange Act.

(b) **Set-Off.** Section 6(f) of the Agreement shall be deleted and replaced with the following:

“(f) **Set-Off.**

- (i) In addition to any rights of set-off a party may have as a matter of law or otherwise, upon the occurrence of an Event of Default with respect to a party (“X”) hereof (or a provision analogous thereto) or a Termination Event where X is the sole Affected Party, the other party (“Y”) shall have the right (but shall not be obliged) without prior notice to X or any other person to set off any obligation of X owing to Y or any Affiliate of Y (whether or not arising under this Agreement, whether or not matured, whether or not contingent and regardless of the currency, place of payment or booking office of the obligation) against any obligations of Y or any Affiliate of Y owing to X (whether or not arising under this Agreement, whether or not matured, whether or not contingent and regardless of the currency, place of payment or booking office of the obligation).
- (ii) For the purpose of cross-currency set off, Y may convert any obligation to another currency at a market rate determined by Y.
- (iii) If any obligation is unascertained, Y may in good faith estimate that obligation and set off in respect of the estimate, subject to the relevant party accounting to the other when the obligation is ascertained.
- (iv) Nothing in this paragraph will have the effect of creating a charge or other security interest. This paragraph shall be without prejudice and in addition to any right of set-off, combination of accounts, lien or other right to which any party is at any time otherwise entitled (whether by operation of law, contract or otherwise).”

(c) **Procedures for Entering Into Transactions.** Party A will deliver to Party B a Confirmation relating to each Transaction.

(d) **Form of Agreement.** The parties hereby agree that the text of the body of the Agreement is intended to be the printed form of 2002 ISDA Master Agreement as published and copyrighted by the International Swaps and Derivatives Association, Inc.

(e) **2002 Master Agreement Protocol.** Party A and Party B each agree that either 1) it is an adherent to the ISDA 2002 Master Agreement Protocol published by the International Swaps and Derivatives Association, Inc. on July 15, 2003 (the “2002 Protocol”) or 2) in accordance with the terms of the 2002 Protocol, certain amendments shall be deemed to be made to:

- (i) sets of definitions and provisions published before 2002 by ISDA (each an “ISDA Definitions Booklet”); and
- (ii) documents containing credit support provisions published before 2002 by ISDA (each called “Credit Support Provisions”):

in each case in accordance with the terms of the 2002 Protocol as specified in Annexes 1-18 thereof. As used in this Agreement (including in all Confirmations related to it), any reference to any ISDA Definitions Booklet and/or Credit Support Provisions shall mean that ISDA Definitions Booklet and/or those Credit Support Provisions as deemed amended in accordance with the terms of the 2002 Protocol.

- (f) **ISDA 2015 Section 871(m) Protocol.** To the extent that either party to this Agreement is not an adhering party to the ISDA 2015 Section 871(m) Protocol published by the International Swaps and Derivatives Association, Inc. on November 2, 2015 and available at [www.isda.org](http://www.isda.org), as may be amended, supplemented, replaced or superseded from time to time (the “871(m) Protocol”), Party A and Party B hereby agree that the provisions and amendments set out in the Attachment to the 871(m) Protocol shall apply to the Agreement and any Confirmation hereunder. The parties further agree that for the purpose of the 871(m) Protocol, (i) solely for purposes of applying such provisions and amendments to this Agreement and any Confirmation hereunder, the Agreement shall be deemed to be a Covered Master Agreement and (ii) the Implementation Date shall be deemed to be the effective date of this Agreement.
- (g) **2015 Universal Resolution Stay Protocol.** The terms of the ISDA 2015 Universal Resolution Stay Protocol are incorporated into and form part of this Agreement, and this Agreement shall be deemed a Covered Agreement for purposes thereof. In the event of any inconsistencies between this Agreement and the Protocol, the Protocol will prevail.
- (h) **Withholding Tax imposed on payments to non-US counterparties under the United States Foreign Account Tax Compliance Act.** “Tax” as used in Part 2(a) of this Schedule (Payer Tax Representation) and “Indemnifiable Tax” as defined in Section 14 of this Agreement shall not include any U.S. federal withholding tax imposed or collected pursuant to Sections 1471 through 1474 of the U.S. Internal Revenue Code of 1986, as amended (the “Code”), any current or future regulations or official interpretations thereof, any agreement entered into pursuant to Section 1471(b) of the Code, or any fiscal or regulatory legislation, rules or practices adopted pursuant to any intergovernmental agreement entered into in connection with the implementation of such Sections of the Code (a “**FATCA Withholding Tax**”). For the avoidance of doubt, a FATCA Withholding Tax is a Tax the deduction or withholding of which is required by applicable law for the purposes of Section 2(d) of this Agreement.
- (i) **Fully Paid Transactions.** Notwithstanding the terms of Sections 2, 5 and 6 of this Agreement, if at any time and so long as one of the parties to this Agreement (“X”) shall have satisfied in full all of its Obligations (as defined below) and shall at that time and at all times subsequent (including with respect to any subsequent Transactions) have no future Obligations, whether absolute or contingent, to the other party (“Y”), then unless Y is required pursuant to appropriate proceedings to return to X or otherwise returns to X upon demand of X any portion of any payment or delivery, (1) Y shall not have the right to suspend any of its obligations under Section 2(a)(i) pursuant to Section 2(a)(iii), (2) (a) the occurrence of an event described in Sections 5(a)(i) to 5(a)(vi), Section 5(a)(viii) and Sections 5(b)(v) and 5(b)(vi) of this Agreement with respect to X, any Credit Support Provider of X or any Specified Entity of X shall not constitute an Event of Default, Potential Event of Default or Termination Event (as the case may be) with respect to X as the Defaulting Party or Affected Party (as the case may be) and (b) Y shall be entitled to designate an Early Termination Date pursuant to Section 6 of this Agreement only as a result of the occurrence of an Event of Default set forth in Section 5(a)(vii) of this Agreement with respect to X, any Credit Support Provider of X or any Specified Entity of X as the Defaulting Party or as a result of a Termination Event set forth in (i) either Section 5(b)(i), 5(b)(ii) or 5(b)(iii) of this Agreement with respect to Y as the Affected party or (ii) Section 5(b)(iv) of this Agreement with respect to Y as the Burdened Party.
- For purposes of this paragraph, “Obligations” shall mean, with respect to a party to this Agreement, any present or future payment or delivery obligation described in Section 2(a)(i) of this Agreement or any present or future obligation to Transfer a Return Amount pursuant to the terms of the Credit Support Annex.
- (j) **Limited Liability.** Without limiting the rights of a Non-defaulting Party or the Non-affected Party to calculate amounts due in respect of an Early Termination Date under Section 6(e), no party shall be required to pay or be liable to the other party for any consequential, indirect or punitive damages.

Part. 6 **FX Transactions and Currency Option Transactions.**

- (a) **Scope.** If the parties enter into or have any outstanding FX Transactions or Currency Option Transactions, as each defined in the FX Definitions (hereinafter defined), (whether before or after this Agreement is entered into), this Part (FX Transactions and Currency Option Transactions) of the Schedule shall apply.
- (b) **Definitions.** Any Confirmation between the parties relating to an FX Transaction or Currency Option Transaction, whether or not it is expressed to be, shall constitute a “Confirmation” as referred to in this Agreement and shall incorporate the 1998 FX and Currency Option Definitions (as published by the International Swaps and Derivatives Association, Inc., the Emerging Markets Traders Association and The Foreign Exchange Committee), including Annex A thereto as in effect on the Trade Date of the relevant Transaction (collectively, the “FX Definitions”). In the event of any inconsistency between the provisions of this Agreement and the FX Definitions, this Agreement will prevail. In the event of any inconsistency between the provisions of any Confirmation and this Agreement or the FX Definitions, such Confirmation will prevail for the purposes of the relevant Transaction.
- (c) **Discharge and Termination of Options.** The FX Definitions are hereby amended by adding the following new Section 3.9:  
**“Section 3.9. Discharge and Termination of Currency Option Transactions.** Unless otherwise agreed, any Call or Put written by a party will automatically be terminated and discharged, in whole or in part, as applicable, against a Call or a Put, respectively, written by the other party, such termination and discharge to occur automatically upon the payment in full of the last Premium payable in respect of such Currency Option Transactions; *provided that*, such termination and discharge may only occur in respect of Currency Option Transactions:
- (a) each being with respect to the same Put Currency and the same Call Currency;
  - (b) each having the same Expiration Date and Expiration Time;
  - (c) each being of the same style (i.e., both being American Style Options, both being European Style Options or both being Bermuda or Mid-Atlantic Style Options);
  - (d) each having the same Strike Price;
  - (e) neither of which shall have been exercised by delivery of a Notice of Exercise;
  - (f) which are otherwise identical in terms that are material for the purposes of offset and discharge;

and, upon the occurrence of such termination and discharge, neither party shall have any further obligation to the other party in respect of the relevant Currency Option Transactions or, as the case may be, parts thereof so terminated and discharged. Such termination and discharge shall be effective notwithstanding that either party (i) may fail to send out a Confirmation, (ii) may fail to record such termination and discharge in its books, or (iii) may send out a Confirmation that is inconsistent with such termination and discharge. In the case of a partial termination and discharge (*i.e.*, where the relevant Currency Option Transactions are for different amounts of the Currency Pair), the remaining portion of the Currency Option Transaction which is partially terminated and discharged shall continue to be a Currency Option Transaction for all purposes hereunder.”

- (d) **Payments Relating to FX Transactions and Currency Option Transactions.** In the case of FX Transactions and Currency Option Transactions only, payments shall be made to the parties as specified in the relevant Confirmation or as otherwise advised.

**IN WITNESS WHEREOF**, the parties have executed this Schedule by their duly authorized officers as of the date hereof.

**MORGAN STANLEY CAPITAL SERVICES LLC**

**MN AIRLINES, LLC**

By: /s/ Charmaine Fearon  
Name Charmaine Fearon  
Title: Authorized Signatory  
Date:

By: /s/ Dave Davis  
Name Dave Davis  
Title: EVP + CFO  
Date:

**TRUST AGREEMENT  
OF  
SCA-1 INTERMEDIATE AIRCRAFT HOLDING TRUST**

THIS TRUST AGREEMENT is made as of September 25, 2018 (this "Agreement"), by and among SCA-I Intermediate Charitable Trust, as Depositor (the "Depositor"), and Wilmington Trust Company, a Delaware trust company (the "Trustee") hereby agree as follows:

1. The trust created hereby shall be known as "SCA- I Intermediate Aircraft Holding Trust" (the "Trust"), in which name the Trustee, to the extent provided herein, may conduct the business of the Trust, make and execute contracts, and sue and be sued.
2. The Depositor hereby assigns, transfers, conveys and sets over to the Trust the sum of \$1.00. The Trustee hereby acknowledges receipt of such amount in trust from the Depositor, which amount shall constitute the initial trust estate. The Trustee hereby declares that it will hold the trust estate in trust for the Depositor. It is the intention of the parties hereto that the Trust created hereby constitute a common law trust under the laws of the State of Delaware, and that this Agreement constitute the governing instrument of the Trust.
3. The Depositor and the Trustee, among others, will enter into an amended and restated Trust Agreement satisfactory to each such party to provide for the contemplated operation of the Trust created hereby. Prior to the execution and delivery of such amended and restated Trust Agreement, the Depositor shall take or cause to be taken any action as may be necessary to obtain prior to such execution and delivery any licenses, consents or approvals required by applicable law or otherwise. Notwithstanding the foregoing, the Trustee may take all actions requested by the Depositor which the Depositor deems necessary, convenient or incidental to effect the transactions contemplated herein. Except as otherwise expressly required by Sections 2 or 5 herein, the Trustee shall not have any duty or obligation under or in connection with this Trust Agreement or any document contemplated hereby, including, without limitation, with respect to the administration of the Trust, and no implied duties or obligations shall be inferred from or read into this Trust Agreement against or with respect to the Trustee. The Trustee has no duty or obligation to supervise or monitor the performance of, or compliance with this Agreement by, the Depositor or any other beneficiaries or any other Trustee of the Trust. The Trustee shall not be liable for the acts or omissions of the Depositor or any other beneficiaries or any other Trustee of the Trust nor shall the Trustee be liable for any act or omission by it in good faith in accordance with the directions of the Depositor. The right of the Trustee to perform any discretionary act enumerated herein shall not be construed as a duty.

Notwithstanding anything in this Trust Agreement to the contrary, the Trustee shall not be authorized and shall have no power to "vary the investment" of any beneficiary within the meaning of Treasury Regulation Section 301.7701-4 (c)(i).

4. The Depositor, as Depositor, is hereby authorized, in its discretion, (i) to negotiate, execute, deliver and perform on behalf of the Trust one or more (a) purchase agreements, escrow agreements, subscription agreements and other similar or related agreements providing for or relating to the sale and issuance of beneficial interests and/or any other interests

in the Trust or (b) assignments, asset transfer agreements, and other similar or related agreements providing for or relating to the acquisition and/or disposition of assets by the Trust; (ii) to take any and all actions to enable the Trust to hold assets, including without limitation, to invest and reinvest funds contributed to the Trust from time to time; (iii) to prepare, execute and file any required tax returns; (iv) to prepare, execute and file an election for the Trust to be taxed as it may determine for federal income tax purposes; (v) to cause the Trust to issue from time to time beneficial interests and/or other interests in the Trust in exchange for such consideration to be contributed to the Trust as the Depositor deems appropriate and cause the Trust to issue from time to time one or more certificates, in such form as it deems appropriate, evidencing such interests in the Trust; and (vi) to prepare, execute and deliver on behalf of the Trust any and all documents, papers and instruments as it deems desirable in connection with any of the foregoing.

5. The Trustee is authorized to take such action or refrain from taking such action under this Trust Agreement as it may be directed in writing by the Depositor from time to time; provided, however, that the Trustee shall not be required to take or refrain from taking any such action if it shall have determined, or shall have been advised by counsel, that such performance is likely to involve the Trustee in personal liability or is contrary to the terms of this Agreement or of any document contemplated here by to which the Trust or the Trustee is a party or is otherwise contrary to law. If at any time the Trustee determines that it requires or desires guidance regarding the application of any provision of this Agreement or any other document, or regarding compliance with any direction it received hereunder, then the Trustee may deliver a notice to the Depositor requesting written instructions as to the course of action desired by the Depositor, and such instructions by or on behalf of the Depositor shall constitute full and complete authorization and protection for actions taken and other performance by the Trustee in reliance thereon. Until the Trustee has received such instructions after delivering such notice, it may refrain from taking any action with respect to the matters described in such notice.

6. The Depositor hereby agrees to (i) reimburse the Trustee for all reasonable expenses (including reasonable fees and expenses of counsel and other experts), (ii) indemnify, defend and hold harmless the Trustee and the officers, directors, employees and agents of the Trustee (collectively, including the Trustee in its individual capacity, the "Indemnified Persons") from and against any and all losses, damages, liabilities, claims, actions, suits, costs, expenses, disbursements (including the reasonable fees and expenses of counsel), taxes and penalties of any kind and nature whatsoever (collectively, "Expenses"), to the extent that such Expenses arise out of or are imposed upon or asserted at any time against such Indemnified Persons with respect to the performance of this Agreement, the creation, operation, administration or termination of the Trust, or the transactions contemplated hereby; provided, however, that the Depositor shall not be required to indemnify an Indemnified Person for Expenses to the extent such Expenses result from the willful misconduct, bad faith or gross negligence of such Indemnified Person, and (iii) advance to each such Indemnified Person Expenses (including reasonable fees and expenses of counsel) incurred by such Indemnified Person, in defending any claim, demand, action, suit or proceeding prior to the final disposition of such claim, demand, action, suit or proceeding upon receipt by the Depositor of an undertaking, by or on behalf of such Indemnified Person, to repay such amount if it shall be determined that such Indemnified Person is not entitled to be indemnified therefor under this Section 6. The obligations of the Depositor under this Section 6 shall survive the resignation or removal of any Trustee, shall survive the termination, amendment, supplement, and/or restatement of this Agreement, and shall survive the transfer by the Depositor of any or all of its interest in the Trust.

7. The number of Trustees of the Trust initially shall be one (1) and thereafter the number of Trustees of the Trust shall be such number as shall be fixed from time to time by a written instrument signed by the Depositor which may increase or decrease the number of Trustees of the Trust; provided, however, to the extent required by the laws of the State of Delaware, there shall at all times be at least one Trustee of the Trust that shall either be a natural person who is a resident of the State of Delaware or, if not a natural person, an entity which has its principal place of business in the State of Delaware and otherwise meets the requirements of applicable law. Subject to the foregoing, the Depositor is entitled to appoint or remove without cause any Trustee of the Trust at any time. Any Trustee of the Trust may resign upon thirty days' prior notice to the Depositor and the other Trustee(s), if any.

8. This Agreement may be executed in one or more counterparts.

9. This Agreement shall be governed by, and construed in accordance with, the laws of the State of Delaware (without regard to conflict of laws principles).

\* \* \* \* \*

IN WITNESS WHEREOF, the parties hereto have caused this Agreement to be duly executed as of the day and year first above written.

SCA-1 INTERMEDIATE CHARITABLE TRUST  
By Wilmington Trust, National Association, not in its  
individual capacity but solely as Trustee

By: /s/ Anita Roselli Woolery  
Name: Anita Roselli Woolery  
Title: Vice President

WILMINGTON TRUST COMPANY  
By Wilmington Trust, National Association, not in its  
individual capacity but solely as Trustee

By: /s/ Anita Roselli Woolery  
Name: Anita Roselli Woolery  
Title: Vice President



**SCA ACQUISITION HOLDINGS, LLC**

**Equity Incentive Plan**

**As Amended and Restated on July 1, 2019**

## ARTICLE I

### PURPOSE OF THE PLAN

The purpose of the SCA Acquisition Holdings, LLC Equity Incentive Plan (the “Plan”) is (a) to further the growth and success of SCA Acquisition Holdings, LLC, a Delaware limited liability company (the “Company”), and its Subsidiaries (as hereinafter defined) by enabling directors and employees of, and consultants to, the Company and its Subsidiaries to acquire Shares (as hereinafter defined), thereby increasing their personal interest in such growth and success, and (b) to provide a means of rewarding outstanding performance by such persons for the Company and/or its Subsidiaries. Awards granted under the Plan (the “Awards”) shall be options to purchase Shares (“Options”) (which Options may be either incentive stock options (“ISOs”) intended to qualify as such under the provisions of Section 422 of the Internal Revenue Code of 1986, as amended (the “Code”), or non-qualified stock options (“NSOs”) to purchase Shares), “sweet equity” Shares that are subject to certain vesting and other restrictions (“Restricted Stock”) and Restricted Stock Units (as defined below). An Award may consist of only Options, only Restricted Stock, only Restricted Stock Units or a combination of Options and/or Restricted Stock and/or Restricted Stock Units. In the Plan, the terms “Parent” and “Subsidiary” mean “Parent Corporation” and “Subsidiary Corporation,” respectively, as such terms are defined in Sections 424(e) and (f) of the Code. Unless the context otherwise requires, any ISO or NSO is referred to in the Plan as an “Option.”

## ARTICLE II

### DEFINITIONS

As used in the Plan, the following terms shall have the meanings set forth below:

“Adoption Agreement” has the meaning set forth in Section 5.10 hereof.

“Affiliate” has the meaning set forth in the first two sentences of the definition of Affiliate of the Company in the Stockholders’ Agreement.

“Apollo” means, collectively, the investment funds managed, sponsored or advised by Apollo Management VIII, L.P. A reference to a member of Apollo is a reference to any such investment fund.

“Award” has the meaning set forth in Article I hereof.

“Award Agreement” means any writing setting forth the terms of an Award that has been duly authorized and approved by the Committee.

“Cause” when used in connection with the Termination of Relationship of a Participant, shall mean (i) the Participant’s indictment for, conviction of, or plea of guilty or *nolo contendere* to, any (x) felony, (y) misdemeanor involving moral turpitude, or (z) other crime involving either fraud or a breach of the Participant’s duty of loyalty with respect to the Company or any Affiliates thereof, or any of its customers or suppliers, (ii) the Participant’s failure to perform duties as reasonably directed by the Board (other than as a consequence of Disability)

after written notice thereof and failure to cure within ten (10) business days of receipt of the written notice, (iii) the Participant's fraud, misappropriation, embezzlement (whether or not in connection with employment), or material misuse of funds or property belonging to the Company or any of its Affiliates, (iv) the Participant's willful violation of the policies of the Company or any of its subsidiaries, or gross negligence in connection with the performance of his duties, after written notice thereof and failure to cure within ten (10) business days of receipt of written notice, (v) the Participant's use of alcohol that interferes with the performance of the Executive's duties or use of illegal drugs, if either (A) the Participant fails to obtain treatment within ten (10) business days after receipt of written notice thereof or (B) the Participant obtains treatment and, following Participant's return to work, the Participant's use of alcohol again interferes with the performance of the Participant's duties or the Participant again uses illegal drugs, (vi) the Participant's material breach of this Agreement, and failure to cure such breach within ten (10) business days after receipt of written notice, or (vii) the Participant's breach of the confidentiality or non-disparagement provisions (excluding unintentional breaches that are cured within ten (10) days after the Participant becomes aware of such breaches, to the extent curable) or the non-competition and non-solicitation provisions to which the Participant is subject. If, within thirty (30) days subsequent to the Participant's termination of employment for any reason other than by the Company for Cause, the Company discovers facts such that the Participant's termination of employment could have been for Cause, the Participant's termination of employment will be deemed to have been for Cause for all purposes, and the Participant will be required to disgorge to the Company all amounts received under their Service Agreement, all equity awards or otherwise that would not have been payable to the Participant had such termination of employment been by the Company for Cause.

"Change in Control" means the occurrence of either of the following: (i) Apollo and its Affiliates (the "Apollo Holders") cease to be the beneficial owners, directly or indirectly, of at least thirty percent (30%) of the combined voting power of the Company's outstanding securities in the aggregate; or (ii) sale of all or substantially all of the assets of the Company and its Subsidiaries, taken as a whole, to a Person or group other than the Apollo Holders; provided, however, that a mere initial public offering or a merger or other acquisition or combination transaction after which the Apollo Holders continue to be the beneficial owners, directly or indirectly, of at least thirty percent (30%) of the combined voting power of the Company's outstanding securities in the aggregate will not result in a Change in Control, but a Change in Control will be deemed to occur if, at any time following an initial public offering or a merger or other acquisition or combination transaction, the Apollo Holders cease to be the beneficial owners of at least thirty percent (30%) of the combined voting power of the Company's outstanding securities in the aggregate.

"Closing Date" means April 11, 2018.

"Code" has the meaning set forth in Article I hereof.

"Commission" means the Securities and Exchange Commission and any other Governmental Authority at the time administering the Securities Act.

"Committee" has the meaning set forth in Section 3.1 hereof.

“Common Stock” has the meaning set forth in the LLC Agreement.

“Company” has the meaning set forth in Article I hereof.

“Company Group” means the Company and its Subsidiaries.

“Data” has the meaning set forth in Section 9.5 hereof.

“Disability,” when used in connection with the Termination of Relationship of a Participant, shall have the same meaning ascribed to such term (or words of like import) in any Service Agreement, or, if no such Service Agreement containing a definition of “Disability” is then in effect, it shall mean the following, unless the applicable Award Agreement states otherwise: a finding by the Committee of the Participant’s incapacitation through any illness, injury, accident or condition of either a physical or psychological nature that has resulted in his or her inability to perform the essential functions of his or her position, even with reasonable accommodations, for one hundred eighty (180) calendar days during any period of three hundred sixty-five (365) consecutive calendar days, and such incapacity is expected to continue.

“Disqualifying Disposition” has the meaning set forth in Article XIV hereof.

“Dividend Equivalent” has the meaning set forth in Section 7.6 hereof.

“Effective Date” has the meaning set forth in Article X hereof.

“Exchange Act” means the Securities Exchange Act of 1934, as amended.

“Executive Committee” has the meaning set forth in Section 3.1 hereof.

“Fair Market Value” means the fair market value of a Share as determined by the Committee.

“Governmental Authority” shall mean any international, national, federal, state, provincial or local governmental, regulatory or administrative authority, agency, commission, court, tribunal, arbitral body or self-regulated entity, whether domestic or foreign.

“ISOs” has the meaning set forth in Article I hereof.

“LLC Agreement” means the Amended and Restated Limited Liability Company Agreement of the Company, dated as of April 11, 2018 (as the same may be amended and or restated from time to time).

“Notice” has the meaning set forth in Section 5.10 hereof.

“NSOs” has the meaning set forth in Article I hereof.

“Option” has the meaning set forth in Article I hereof.

“Option Price” has the meaning set forth in Section 5.6 hereof.

“Option Shares” has the meaning set forth in Section 5.10(b) hereof.

“Participant” has the meaning set forth in Section 4.1 hereof.

“Person” has the meaning set forth in the Stockholders’ Agreement.

“Plan” has the meaning set forth in Article I hereof.

“Purchase Price” has the meaning set forth in Section 6.1 hereof.

“Reserved Shares” means the number of Shares approved by the Committee from time to time for issuance hereunder.

“Restricted Stock” has the meaning set forth in Article I hereof.

“Restricted Stock Unit” means an unfunded, unsecured right to receive, on the applicable settlement date, one Share or an amount in cash or other consideration determined by the Committee equal to the value thereof as of such payment date, which right may be subject to certain vesting conditions and other restrictions.

“Restrictive Covenants” has the meaning set forth in Section 9.6(f) hereof.

“Securities Act” means the Securities Act of 1933, as amended.

“Service Agreement” means a written employment agreement, consultancy agreement, directorship agreement or similar services agreement or offer letter between a Participant and any member of the Company Group.

“Shares” means shares of Common Stock.

“Stockholder” has the meaning set forth in the LLC Agreement.

“Stockholders’ Agreement” means the SCA Acquisition Holdings, LLC Stockholders’ Agreement, dated as of April 11, 2018, among the Company, AP VIII (SCA Stock AIV), LLC, and the holders party thereto, including each of Jude Bricker and David Siegel, as it is amended, supplemented or restated from time to time.

“Subsidiary” has the meaning set forth in the Stockholders’ Agreement.

“Termination Date” means the tenth anniversary of the Effective Date.

“Termination of Relationship” means (a) if the Participant is an employee of any member of the Company Group, the termination of the Participant’s employment relationship with such member of the Company Group for any reason; (b) if the Participant is a consultant to the Company Group, the termination of the Participant’s consulting relationship with the Company Group for any reason; and (c) if the Participant is a director of any member of the Company Group, the termination of the Participant’s service relationship with such member of the Company Group for any reason; provided, that there shall be no “Termination of Relationship” in situations where the Participant, in agreement with the Company or its Affiliates, around the same time enters into a new employment or service agreement with the Company or any of its Affiliates or takes up a director mandate in the Company or any of its Affiliates or continues another existing employment or service agreement or director mandate within the Company or any of its Affiliates.

“Vested Options” means Options that have vested in accordance with the applicable Award Agreement.

“Vested Restricted Stock Units” means Restricted Stock Units that have vested in accordance with the applicable Award Agreement.

### ARTICLE III

#### ADMINISTRATION OF THE PLAN; SHARES SUBJECT TO THE PLAN

##### **3.1 Committee.**

The Plan shall be administered by, and all Awards under the Plan shall be authorized by, the Executive Committee of the Board of Directors of the Company (the “Executive Committee”) or such other committee that has been authorized to administer the Plan (the “Committee”). The term “Committee” shall, for all purposes of the Plan be deemed to refer to the Executive Committee if the Executive Committee is administering the Plan.

##### **3.2 Procedures.**

The Committee shall adopt such rules and regulations as it shall deem appropriate concerning the holding of meetings and the administration of the Plan.

##### **3.3 Interpretation.**

Except as may otherwise be expressly reserved to the Committee as provided herein, and with respect to any Award, except as may otherwise be provided in the Award Agreement evidencing such Award, the Committee shall have all powers with respect to the administration of the Plan, including the interpretation of the provisions of the Plan and any Award Agreement (including, without limitation, whether any particular Termination of Relationship is for Cause), and all decisions of the Committee, as the case may be, shall be reasonable and made in good faith and shall be conclusive and binding on all Participants in the Plan.

##### **3.4 Binding Determinations.**

Any action taken by, or inaction of, the Company or the Committee relating or pursuant to the Plan and within its authority hereunder or under applicable law shall be within the absolute discretion of that entity or body and shall be conclusive and binding upon all Persons. Any interpretations, decisions or determinations of the Committee need not be the same with respect to each Participant (whether or not such Participants are similarly situated). Neither the Company nor the Committee, nor any member thereof or Person acting at the direction thereof, shall be liable for any act, omission, interpretation, construction or determination made in good faith in connection with the Plan (or any Award), and all such Persons shall be entitled to indemnification and reimbursement by the Company in respect of any claim, loss, damage or expense (including, without limitation, attorneys’ fees) arising or resulting therefrom to the fullest extent permitted by law and/or under any directors and officers liability insurance coverage that may be in effect from time to time.

### **3.5 Reliance on Experts.**

In making any determination or in taking or not taking any action under the Plan, the Company and the Committee may obtain and may rely upon the advice of experts, including employees of and professional advisors to the Company. No director, officer or agent of the Company Group shall be liable for any such action or determination taken or made or omitted in good faith.

### **3.6 Delegation.**

The Committee may delegate ministerial, non-discretionary functions to individuals who are officers or employees of the Company or any of its Subsidiaries or Affiliates or to third parties.

### **3.7 Number of Shares.**

Subject to the provisions of Article VIII (relating to adjustments upon changes in capital structure and other corporate transactions), an aggregate of 369,828 Shares shall be Reserved Shares hereunder. Shares that are subject to or underlie Awards granted under the Plan that expire or for any reason are canceled or terminated, are forfeited, are repurchased, fail to vest or for any other reason are not issued or delivered under the Plan will again, except to the extent prohibited by law or applicable listing or regulatory requirements, be available for subsequent Awards under the Plan.

## **ARTICLE IV**

### **ELIGIBILITY; AWARD AGREEMENTS**

#### **4.1 General.**

Awards may be granted under the Plan only to Persons who are employees or directors of, or consultants to, the Company or any of its Subsidiaries on the date of grant. A Person's eligibility to be granted an Award under the Plan is not a commitment that any Award will be granted to that Person under the Plan. Each Person to whom an Award is granted under the Plan is referred to herein as a "Participant."

#### **4.2 Exceptions.**

Notwithstanding anything contained in Section 4.1 to the contrary, no ISO may be granted under the Plan to an employee who owns, directly or indirectly (within the meaning of Sections 422(b)(6) and 424(d) of the Code), stock possessing more than 10% of the total combined voting power of all classes of stock of the Company or of its Parent, if any, or any of its Subsidiaries, unless (a) the Option Price of the Shares subject to such ISO is fixed at not less than 110% of the Fair Market Value of such Shares on the date of the grant (as determined in accordance with the definition thereof), and (b) such ISO by its terms is not exercisable after the expiration of five years from the date on which it is granted.

### **4.3 Award Agreements.**

Each Award granted under the Plan shall be evidenced by an Award Agreement in the form approved by the Committee. The Award Agreement shall contain the terms established by the Committee for that Award, as well as any other terms, provisions, or restrictions that the Committee may impose on the Award or any Shares subject to the Award, in each case subject to the applicable provisions and limitations of the Plan. The Committee may require that the spouse of any married recipient of an Award also promptly execute and return to the Company the Award Agreement evidencing the Award granted to the recipient or such other spousal consent form that the Committee may require in connection with the grant of the Award.

## **ARTICLE V**

### **OPTIONS**

#### **5.1 General.**

Options may be granted under the Plan at any time and from time to time on or prior to the Termination Date; provided that (a) Options granted to employees of the Company Group shall be, in the discretion of the Committee, either ISOs or NSOs on the date of the grant and (b) Options granted to consultants and non-employee directors shall be NSOs. Subject to the provisions of the Plan, the Committee shall have plenary authority, in its sole discretion and consistent with applicable law, to determine:

- (a) The Persons (from among the class of Persons eligible to receive Options under the Plan) to whom Options shall be granted;
- (b) The time or times at which Options shall be granted; and
- (c) The number of Shares for which an Option may be exercisable.

#### **5.2 Option Terms.**

Each Option granted under the Plan shall be designated as an ISO or an NSO and shall be subject to the terms and conditions applicable to ISOs and/or NSOs (as the case may be) set forth in the Plan. Each Option shall specify the number of Shares for which such Option shall be exercisable and the exercise price for such Shares. In addition, each Option shall be evidenced by an Award Agreement that shall be executed by the Company and the Participant.

#### **5.3 Vesting.**

The Committee shall determine whether and to what extent any Options that are exercisable for Shares are also subject to vesting based upon the Participant's continued service to, and/or the performance of duties for, the Company Group and/or the attainment of specified performance goals.



#### **4.4 Date of Grant.**

The date of grant of an Option under the Plan shall be the date as of which the Committee approves the grant.

#### **4.5 Shares Subject to Options.**

Options shall be granted to purchase a specified number of Shares not to exceed, in the aggregate, the Reserved Shares. Options may be exercisable for whole Shares only.

#### **4.6 Option Price.**

The price (the “Option Price”) at which each Share underlying an Option may be purchased shall be determined by the Committee and set forth in the Award Agreement; provided, however, that in the case of an ISO, such Option Price shall in no event be less than 100% (or 110% if Section 4.2 hereof is applicable) of the Fair Market Value of the Shares on the date of the grant.

#### **4.7 Automatic Termination of Options.**

Each Option granted under the Plan shall terminate automatically and shall become null and void and be of no further force or effect upon such date or dates set forth in the applicable Award Agreement, consistent with the terms of the Plan. Any Shares that are not acquired as a result of an Option’s expiration without being fully exercised shall be available for award by the Committee to another eligible Person.

#### **4.8 Limitations on ISOs; Notice to Participants Granted ISOs.**

In accordance with Section 422(d) of the Code, to the extent that the aggregate Fair Market Value of all stock with respect to which incentive stock options are exercisable for the first time by a Participant during any calendar year (under all plans of the Company Group) exceeds \$100,000, such ISOs shall be treated as NSOs.

#### **4.9 Payment of Option Price.**

A Participant shall pay for the exercise of a Vested Option in United States currency by either (i) cash or personal or certified check payable to the Company in an amount equal to the aggregate Option Price of the Shares with respect to which the Option is being exercised or (ii) with the consent of the Committee, by instructing the Company to withhold from the number of Shares with respect to which the Option is being exercised a number of Shares having, as of the date of such exercise, a Fair Market Value equal to the aggregate Option Price of the Shares with respect to which the Option is being exercised. Notwithstanding the foregoing, in the case of an initial public offering, a Vested Option may be exercised (following the expiration of any required “lock-ups” or similar restrictions) under the above clause (ii) (withholding of Shares) at the Participant’s option.

#### **4.10 Notice of Exercise.**

A Participant (or other Person, as provided in Section 9.2) may exercise an Option (for the Shares represented thereby) in whole or in part (but for the purchase of whole Shares only), as provided in the Award Agreement evidencing his or her Option, by delivering a written notice (the “Notice”) to the Secretary of the Company. The Notice shall state:

- (a) that the Participant elects to exercise the Option;
- (b) the number of Shares with respect to which the Option is being exercised (the “Option Shares”);
- (c) the method of payment for the Option Shares (which method must be available to the Participant under the terms of his or her Award Agreement);
- (d) the date upon which the Participant desires to consummate the purchase (which date must be prior to the termination of such Option);
- (e) a copy of any election filed or intended to be filed by the Participant with respect to such Option Shares pursuant to Section 83(b) of the Code; and
- (f) any additional provisions consistent with the Plan as the Committee may from time to time require.

The exercise date of an Option shall be the date on which the Company receives the Notice from the Participant. Such Notice shall also contain, to the extent that such Participant is not then a party to the Stockholders’ Agreement, an adoption agreement, in form and substance satisfactory to the Committee, pursuant to which the Participant agrees to become a party to the Stockholders’ Agreement (an “Adoption Agreement”). The Participant shall also execute any other documentation as reasonably required by the Committee.

#### **4.11 Issuance of Certificates.**

The Company shall issue stock certificates in the name of the Participant (or such other Person exercising the Option in accordance with the provisions of Section 9.2), for the securities purchased upon exercise of an Option as soon as practicable after receipt of the Notice and payment of the aggregate Option Price for such securities; provided that the Company may elect to not issue any fractional Shares upon the exercise of any Options (determining the fractional Shares after aggregating all Shares issuable to a single holder as a result of an exercise of an Option for more than one Share) and in lieu of issuing such fractional Shares, shall pay the Participant the Fair Market Value thereof. Neither the Participant nor any Person exercising an Option in accordance with the provisions of Section 9.2 shall have any privileges as a Stockholder of the Company with respect to any Shares subject to an Option granted under the Plan until the date of issuance of stock certificates pursuant to this Section 5.11. Notwithstanding the foregoing, the Company shall not be required to deliver stock certificates to the Participant evidencing the Shares issued in connection with the exercise of Options if instead such Shares shall be recorded in the books of the Company (or, as applicable, its transfer agent or stock plan administrator).

## ARTICLE VI

### RESTRICTED STOCK AWARDS

#### **6.1 General.**

Restricted Stock may be granted or sold under the Plan at any time and from time to time on or prior to the Termination Date. Subject to the provisions of the Plan, the Committee shall have plenary authority, in its sole discretion and consistent with applicable law, to determine:

- (a) the Persons (from among the class of Persons eligible to receive Restricted Stock under the Plan) to whom Restricted Stock Awards shall be granted or sold;
- (b) the time or times at which Restricted Stock shall be granted or sold;
- (c) the number of Shares covered by a Restricted Stock Award; and
- (d) the per-Share purchase price, if any, for the Shares of Restricted Stock (the "Purchase Price").

#### **6.2 Restricted Stock Award Terms.**

Each Restricted Stock Award shall specify the number of Shares covered thereby and the Purchase Price, if any, for such Shares. In addition, each Restricted Stock Award shall be evidenced by an Award Agreement that shall be executed by the Company and the Participant.

#### **6.3 Vesting.**

The Committee shall determine whether and to what extent any Shares covered by Restricted Stock Awards are also subject to vesting based upon the Participant's continued service to, or the performance of duties for, the Company Group and/or the attainment of specified performance goals.

#### **6.4 Payment of Purchase Price.**

The Purchase Price, if any, for the Shares of Restricted Stock shall be determined by the Committee and set forth in the Award Agreement. A Participant shall pay the Purchase Price for the Shares of Restricted Stock in United States currency by cash or personal or certified check payable to the Company in an amount equal to the aggregate Purchase Price of the Shares covered by the Restricted Stock Award. In the event that the Participant files an election under Section 83(b) of the Code in connection with the purchase of the Restricted Stock, the Participant must promptly provide a copy of such election to the Secretary of the Company.

### **6.5 Issuance of Certificates.**

The Company shall issue stock certificates in the name of the Participant for the securities purchased or granted pursuant to a Restricted Stock Award as soon as practicable after the grant of the Award and receipt of the payment, if any, of the aggregate Purchase Price for such securities. The Participant shall not have any privileges as a Stockholder of the Company with respect to any Shares covered by a Restricted Stock Award granted under the Plan unless the Participant is a party to the Stockholders' Agreement (or has signed an Adoption Agreement with respect thereto) and until the date of issuance of stock certificates pursuant to this Section 6.5. The Company may require that any stock certificates issued in respect of Shares of Restricted Stock be deposited in escrow by the Participant, together with a stock power endorsed in blank, with the Company (or its designee). Notwithstanding the foregoing, the Company shall not be required to deliver stock certificates to the Participant evidencing the Shares issued in connection with the Restricted Stock Award if instead such Shares shall be recorded in the books of the Company (or, as applicable, its transfer agent or stock plan administrator).

### **6.6 Dividends.**

Participants holding Shares of Restricted Stock shall be entitled to all ordinary cash dividends paid with respect to such Shares, unless otherwise provided by the Committee in the applicable Award Agreement. In addition, unless otherwise provided by the Committee, if any dividends or distributions are paid in Shares, or consist of a dividend or distribution to holders of Common Stock of property other than an ordinary cash dividend, the Shares or other property will be subject to the same restrictions on transferability and forfeitability as the Shares of Restricted Stock with respect to which they were paid. Each dividend payment will be made as provided in the applicable Award Agreement, but in no event later than the end of the calendar year in which the dividends are paid to holders of the Common Stock or, if later, the 15<sup>th</sup> day of the third month following the later of (A) the date the dividends are paid to the holders of the Common Stock, and (B) the date the dividends are no longer subject to forfeiture.

## **ARTICLE VII**

### **RESTRICTED STOCK UNIT AWARDS**

#### **7.1 General.**

Restricted Stock Units may be granted under the Plan at any time and from time to time on or prior to the Termination Date. Subject to the provisions of the Plan, the Committee shall have plenary authority, in its sole discretion and consistent with applicable law, to determine:

- (a) the Persons (from among the class of Persons eligible to receive Restricted Stock Units under the Plan) to whom Restricted Stock Unit Awards shall be granted;
- (b) the time or times at which Restricted Stock Units shall be granted and the settlement date for such Restricted Stock Units; and
- (c) the number of Shares with respect to which a Restricted Stock Unit Award relates.

#### **7.2 Restricted Stock Unit Award Terms.**

Each Restricted Stock Unit Award shall specify the number of Restricted Stock Units covered thereby and the settlement date for such Restricted Stock Units. In addition, each Restricted Stock Unit Award shall be evidenced by an Award Agreement that shall be executed by the Company and the Participant.

### **6.3 Vesting.**

The Committee shall determine whether and to what extent the Restricted Stock Unit Awards are also subject to vesting based upon the Participant's continued service to, or the performance of duties for, the Company Group and/or the attainment of specified performance goals.

### **6.4 Settlement.**

Upon the vesting of a Restricted Stock Unit, the Participant shall be entitled to receive from the Company one Share or an amount of cash or other property equal to the Fair Market Value of a Share on the settlement date, as provided in the applicable Award Agreement. The Committee may provide that settlement of Restricted Stock Units shall occur upon or as soon as reasonably practicable after the vesting of the Restricted Stock Units or shall instead be deferred, on a mandatory basis or at the election of the Participant, in a manner that complies with Section 409A of the Code and other applicable law.

### **6.5 Issuance of Certificates.**

The Company shall issue stock certificates in the name of the Participant for the securities issued pursuant to a Restricted Stock Unit Award as soon as practicable after the settlement of the Award and the issuance of such securities. The Participant shall not have any privileges as a Stockholder of the Company, including any voting rights, with respect to any Shares underlying Restricted Stock Unit Awards granted under the Plan prior to the settlement date, and the Participant shall not have any privileges as a Stockholder of the Company with respect to Shares issued in connection with the settlement of such Award until the Participant is a party to the Stockholders' Agreement (or has signed an Adoption Agreement with respect thereto) and until the date of issuance of stock certificates pursuant to this Section 7.5. Notwithstanding the foregoing, the Company shall not be required to deliver stock certificates to the Participant evidencing the Shares issued in connection with the settlement of a Restricted Stock Unit Award if instead such Shares shall be recorded in the books of the Company (or, as applicable, its transfer agent or stock plan administrator).

### **6.6 Dividend Equivalents.**

To the extent provided by the Committee in the applicable Award Agreement, a grant of Restricted Stock Units may provide a Participant with the right to receive the equivalent value (in cash or in Shares) of ordinary cash dividends paid with respect to the Shares ("Dividend Equivalents"). Dividend Equivalents may be paid currently or credited to an account for the Participant, may be settled in Shares and/or cash or other property and will be subject to the same restrictions on transferability and forfeitability as the Restricted Stock Units with respect to which they were are paid, as determined by the Committee, subject, in each case, to such terms and conditions as the Committee shall establish and set forth in the applicable Award Agreement.

## ARTICLE VIII

### ADJUSTMENTS

#### **8.1 Changes in Capital Structure.**

If the Common Stock is changed by reason of a stock split, reverse stock split, or stock combination, stock dividend or distribution, or converted into or exchanged for other securities as a result of a merger, consolidation or reorganization, or in connection with extraordinary cash dividends on the Common Stock, the Committee shall make such adjustments in the number and class of shares of stock available under the Plan as shall be necessary, in the Committee's good faith discretion, to preserve for a Participant rights substantially proportionate to his or her rights existing immediately prior to such transaction or event (but subject to the limitations and restrictions on such rights), including, without limitation, a corresponding adjustment changing the number and class of shares allocated to, and the Option Price or Purchase Price of, each Award or portion thereof outstanding at the time of such change. Notwithstanding anything contained in the Plan to the contrary, in the case of ISOs, no adjustment under this Section 8.1 shall be appropriate if such adjustment (a) would constitute a modification, extension or renewal of such ISOs within the meaning of Sections 422 and 424 of the Code, and the regulations promulgated by the Treasury Department thereunder, or (b) would, under Section 422 of the Code and the regulations promulgated by the Treasury Department thereunder, be considered the adoption of a new plan requiring Stockholder approval. The Company will not, in any event, permit the exercise price of any Option to be less than the par value of the Common Stock.

#### **8.2 Special Rules.**

The following rules shall apply in connection with Section 8.1 above:

(a) No adjustment shall be made for cash dividends (except as described in Section 8.1) or the issuance to Stockholders of rights to subscribe for additional Shares or other securities; and

(b) Any adjustments referred to in Section 8.1 shall be made by the Committee in its reasonable discretion and shall, absent manifest error, be conclusive and binding on all Persons holding any Awards granted under the Plan.

#### **8.3 Deemed Repurchase and Come-Along Rights.**

(a) Without limiting the application of any provisions of the Stockholders' Agreement, and without regard to whether a Participant is already a party to the Stockholders' Agreement, upon the occurrence of any event that would give rise to a Repurchase Right (as defined in the Stockholders' Agreement) or a Come-Along Right (as defined in the Stockholders' Agreement), in each case to which Shares underlying an Option or Restricted Stock Unit would have been subject had such Option been exercised, or such Restricted Stock Unit been settled, as applicable, and had the Participant been delivered such Shares, immediately prior thereto, the Company or its designee may, but shall not be obligated to, cancel all or any portion of the Subject Awards (as defined below) for an amount of consideration equal to the consideration that would have been paid to a holder of the Shares underlying such Subject Awards in connection with the

exercise of such Repurchase Right or Come-Along Right, as applicable, under the Stockholders' Agreement, less applicable tax withholding (and in the case of Options, less the Option Price thereof, and in the event that such amount would be equal to or less than zero, such Option may be canceled for no consideration); provided, that if necessary to comply with Section 409A of the Code, such amount shall not be payable with respect to any Restricted Stock Unit until the earliest time permitted by Section 409A of the Code. As used herein, the term "Subject Award" means, with respect to an Award, the portion of such Award relating to the number of Shares that would be subject to such Repurchase Right or Come-Along Right had they been issued to the Participant holding such Award and outstanding immediately prior thereto. Such cancellation and payment may be effected pursuant to any arrangement deemed appropriate by the Committee.

(b) For the sake of clarity, notwithstanding the foregoing, the outstanding Options, Restricted Stock, and Restricted Stock Units shall otherwise be subject to such adjustments as determined by the Committee pursuant to Section 8.1. Further, in no event shall the failure of the Company or its designee to exercise its rights under this Section 8.3 in connection with a Repurchase Right or Come-Along Right prejudice any of the Company's or its designee's rights under the Stockholders' Agreement with respect to either (i) any other Shares held by any Participant that may be subject to such Repurchase Right or Come-Along Right or (ii) any Shares issued to a Participant in the future upon exercise or settlement of any Subject Award that may in the future be subject to a future Repurchase Right or Come-Along Right.

## ARTICLE IX

### RESTRICTIONS ON AWARDS

#### **9.1 Compliance With Securities Laws.**

No Awards shall be granted under the Plan, and no securities shall be issued and delivered pursuant to Awards granted under the Plan, unless and until the Company and/or the Participant shall have complied with all applicable registration, listing and/or qualification requirements under any applicable law and all other requirements of law or of any regulatory agencies having jurisdiction.

The Committee in its discretion may, as a condition to the delivery of any Shares pursuant to any Award granted under the Plan, require a Participant (a) to represent in writing that the securities received pursuant to such Award are being acquired for investment and not with a view to distribution and (b) to make such other representations and warranties as are deemed reasonably appropriate by the Company. Stock certificates representing securities acquired under the Plan that have not been registered under the Securities Act shall, if required by the Committee, bear the legends as may be required by the Stockholders' Agreement and Award Agreement evidencing a particular Award.

#### **9.2 Nonassignability of Awards.**

No Award granted under the Plan shall be assignable or otherwise transferable by the Participant, except by will or by the laws of descent and distribution. An Award may be exercised during the lifetime of the Participant only by the Participant. If a Participant dies, his or her Awards shall thereafter be exercisable, during the period specified in the applicable Award Agreement (as the case may be), by his or her executors or administrators to the full extent (but only to such extent) to which such Awards were exercisable by the Participant at the time of his or her death.

### **8.3 No Evidence of Employment or Other Service Relationship; No Rights to Future Awards.**

Nothing contained in the Plan or in any Award Agreement shall confer upon any Participant any right with respect to the continuation of his or her employment by or other service relationship with the Company Group or interfere in any way with the right of the Company Group (subject to the terms of any separate agreement to the contrary) at any time to terminate such employment or other service relationship or to increase or decrease the compensation of the Participant from the rate in existence at the time of the grant of an Award. The grant of Awards under the Plan is a one-time benefit and does not create any contractual or other right to receive any other grant of other Awards under the Plan in the future. The grant of an Award does not form part of the Participant's entitlement to remuneration or benefits in terms of his or her employment or other service relationship with the Company Group.

### **8.4 Provisions for Foreign Participants – In General.**

The Committee may modify Awards granted to Participants who are foreign nationals or employed outside the United States or establish subplans or procedures under the Plan to address differences in laws, rules, regulations or customs of such foreign jurisdictions with respect to tax, securities, currency, employee benefit or other matters.

### **8.5 Data Privacy.**

As a condition of receipt of any Award, each Participant explicitly and unambiguously consents to the collection, use and transfer, in electronic or other form, of personal data as described in this paragraph by and among, as applicable, the Company and its Subsidiaries and Affiliates for the exclusive purpose of implementing, administering and managing the Participant's participation in the Plan. The Company and its Subsidiaries and Affiliates may hold certain personal information about a Participant, including but not limited to, the Participant's name, home address and telephone number, date of birth, social security or insurance number or other identification number, salary, nationality, job title(s), any shares of stock held in the Company or any of its Subsidiaries and Affiliates, details of all Awards, in each case, for the purpose of implementing, managing and administering the Plan and Awards (the "Data"). The Company and its Subsidiaries and Affiliates may transfer the Data amongst themselves as necessary for the purpose of implementation, administration and management of a Participant's participation in the Plan, and the Company and its Subsidiaries and Affiliates may each further transfer the Data to any third parties assisting the Company in the implementation, administration and management of the Plan. These recipients may be located in the Participant's country, or elsewhere, and the Participant's country may have data privacy laws and protections that are different from those of the recipients' country. Through acceptance of an Award, each Participant authorizes such recipients to receive, possess, use, retain and transfer the Data, in electronic or other form, for the purposes of implementing, administering and managing the Participant's



participation in the Plan, including any requisite transfer of such Data as may be required to a broker or other third party with whom the Company or the Participant may elect to deposit any Shares. The Data related to a Participant will be held only as long as is necessary to implement, administer, and manage the Participant's participation in the Plan. A Participant may, at any time, view the Data held by the Company with respect to such Participant, request additional information about the storage and processing of the Data with respect to such Participant, recommend any necessary corrections to the Data with respect to the Participant or refuse or withdraw the consents herein in writing, in any case without cost, by contacting his or her local human resources representative. The Company may cancel a Participant's ability to participate in the Plan and, in the Committee's discretion, the Participant may forfeit any outstanding Awards if the Participant refuses or withdraws his or her consents as described herein. For more information on the consequences of refusal to consent or withdrawal of consent, Participants may contact their local human resources representative.

#### **8.6 Restrictive Covenants.**

By accepting the grant of any Award hereunder, in addition to any other representations, warranties, and covenants set forth in (but subject to any exceptions set forth in) any Award Agreement, Service Agreement or other document required by the Committee with respect to such grant, each Participant agrees to be subject to and comply with the following covenants.

(a) Non-Solicitation; No Hire. To the fullest extent permitted by applicable law, unless otherwise provided in an Award Agreement or Service Agreement, each Participant agrees that during Participant's employment or other service relationship with the Company Group, and for the one (1) year period following the Participant's Termination of Relationship for any reason, the Participant will not, directly or indirectly, on Participant's own behalf or on behalf of another (i) solicit, induce or attempt to solicit or induce any officer, director or employee of the Company Group to terminate their relationship with or leave the employ of the Company Group, or in any way interfere with the relationship between any member of the Company Group, on the one hand, and any officer, director or employee thereof, on the other hand, (ii) hire (or other similar arrangement) any Person (in any capacity whether as an officer, director, employee or consultant) who is or at any time was an officer, director or employee of the Company Group until six (6) months after such individual's relationship (whether as an officer, director or employee) with the Company Group has ended, or (iii) induce or attempt to induce any customer, supplier, prospect, licensee or other business relation of the Company Group to cease doing business with the Company Group, or in any way interfere with the relationship between any such customer, supplier, prospect, licensee or business relation, on the one hand, and the Company Group, on the other hand.

(b) Non-Competition. To the fullest extent permitted by applicable law, unless otherwise provided in an Award Agreement or Service Agreement, each Participant agrees that during the Participant's employment or other service relationship with the Company Group, and for the Restricted Period (as defined below) following the Participant's Termination of Relationship for any reason, the Participant will not, directly or indirectly, on the Participant's own behalf or on behalf of another engage in, have any equity interest in, or manage or operate any Person, firm, corporation, partnership, business or entity (whether as director, officer, employee,

agent, representative, partner, security holder, consultant, or otherwise) that engages in (either directly or through any subsidiary or Affiliate thereof) any business or activity that competes with any of the businesses of the Company or any entity owned by the Company. Notwithstanding the foregoing, the Participant shall be permitted to acquire a passive stock or equity interest in such a business, provided that the stock or other equity interest acquired is not more than five percent (5%) of the outstanding interest in such business. For purposes of this Section 9.6(b), the term "Restricted Period" shall mean the following: (i) for Participants with the title Director or Sr. Director who voluntarily terminate employment with the Company or are terminated by the Company for "Cause", six (6) months, and for Participants with the title Director or Sr. Director who are involuntarily terminated without "Cause", such time period as determined by the Company which may be zero (0) and up to a maximum of twelve (12) months, provided, that, a member of the Company Group continues to pay the Participant his or her base salary during the Restricted Period elected by the Company; and (ii) for all other Participants, twelve (12) months.

(c) Nondisclosure of Confidential Information; Return of Property. Each Participant recognizes and acknowledges that he or she has access to the confidential information and/or has had material contact with the Company Group's customers, suppliers, licensees, representatives, agents, partners, licensors, or business relations. Each Participant agrees that he or she will not, directly or indirectly, at any time during or after such time as such Participant is a Participant in the Plan, disseminate, disclose or publish, or use for the Participant's benefit or the benefit of any Person, any confidential or proprietary information or trade secrets of or relating to the Company Group, including, without limitation, information with respect to the Company Group's operations, processes, products, inventions, business practices, finances, principals, vendors, suppliers, customers, potential customers, marketing methods, costs, prices, contractual relationships, regulatory status, compensation paid to employees or other terms of employment, or deliver to any Person any document, record, notebook, computer program or similar repository of or containing any such confidential or proprietary information or trade secrets. Upon the Participant's termination of employment for any reason, the Participant shall promptly deliver to the Company all correspondence, drawings, manuals, letters, notes, notebooks, reports, programs, plans, proposals, financial documents, or any other documents concerning the Company Group's customers, business plans, marketing strategies, products or processes. The Participant may respond to a lawful and valid subpoena or other legal process but shall give the Company Group the earliest possible notice thereof, shall, as much in advance of the return date as possible, make available to the Company Group and its counsel the documents and other information sought and, if requested by the Company Group, shall reasonably assist such counsel in resisting or otherwise responding to such process.

(d) Non-Disparagement. The Participant shall not, at any time, directly or indirectly, knowingly disparage, criticize, or otherwise make derogatory statements regarding the Company Group, or any of its successors, directors or officers. The foregoing shall not be violated by the Participant's truthful responses to legal process or inquiry by a governmental authority.

(e) Intellectual Property Rights.

(i) The Participant agrees that the results and proceeds of the Participant's services for the Company Group (including, but not limited to, any trade secrets, products, services, processes, know-how, designs, developments, innovations, analyses, drawings, reports, techniques, formulas, methods, developmental or experimental work, improvements, discoveries, inventions, ideas, source and object codes, programs, matters of a literary, musical, dramatic or otherwise creative nature, writings and other works of authorship) resulting from services performed for the Company Group and any works in progress, whether or not patentable or registrable under copyright or similar statutes, that were made, developed, conceived or reduced to practice or learned by the Participant, either alone or jointly with others (collectively, "Inventions"), shall be works-made-for-hire and the Company (or, if applicable or as directed by the Company Group) shall be deemed the sole owner throughout the universe of any and all trade secret, patent, copyright and other intellectual property rights (collectively, "Proprietary Rights") of whatsoever nature therein, whether or not now or hereafter known, existing, contemplated, recognized or developed, with the right to use the same in perpetuity in any manner the Company determines in its sole discretion, without any further payment to the Participant whatsoever. If, for any reason, any of such results and proceeds shall not legally be a work-made-for-hire and/or there are any Proprietary Rights which do not accrue to the Company Group under the immediately preceding sentence, then the Participant hereby irrevocably assigns and agrees to assign any and all of the Participant's right, title and interest thereto, including, without limitation, any and all Proprietary Rights of whatsoever nature therein, whether or not now or hereafter known, existing, contemplated, recognized or developed, to the Company (or, if applicable or as directed by the Company, any of its Subsidiaries or Affiliates), and the Company or such Subsidiaries or Affiliates shall have the right to use the same in perpetuity throughout the universe in any manner determined by the Company or such Subsidiaries or Affiliates without any further payment to the Participant whatsoever. As to any Invention that the Participant is required to assign, the Participant shall promptly and fully disclose to the Company all information known to the Participant concerning such Invention. The Participant hereby waives and quitclaims to the Company Group any and all claims, of any nature whatsoever, that the Participant now or may hereafter have for infringement of any Proprietary Rights assigned hereunder to the Company Group.

(ii) The Participant agrees that, from time to time, as may be requested by the Company and at the Company's sole cost and expense, the Participant shall do any and all things that the Company may reasonably deem useful or desirable to establish or document the Company Group's exclusive ownership throughout the United States of America or any other country of any and all Proprietary Rights in any such Inventions, including, without limitation, the execution of appropriate copyright and/or patent applications or assignments. To the extent the Participant has any Proprietary Rights in the Inventions that cannot be assigned in the manner described above, the Participant unconditionally and irrevocably waives the enforcement of such Proprietary Rights. This Section 9.6(e) is subject to and shall not be deemed to limit, restrict or constitute any waiver by the Company Group of any Proprietary Rights of ownership to which the Company Group may be entitled by operation of law by virtue of the Participant's employment with, or service to, the Company Group. The Participant further agrees that, from time to time, as may be requested by the Company and at the Company's sole cost and expense, the Participant shall assist the Company Group in every proper and lawful way to obtain and from time to time enforce Proprietary Rights relating to Inventions in any and all countries. To this end, the Participant shall execute, verify and deliver such documents and perform such other acts (including appearances as a witness) as the Company may reasonably request for use in applying for, obtaining, perfecting, evidencing, sustaining, and enforcing such Proprietary Rights and the assignment thereof. In addition, the Participant shall execute, verify, and deliver assignments of such Proprietary Rights to the Company or its designees. The Participant's obligation to assist the Company Group with respect to Proprietary Rights relating to such Inventions in any and all countries shall continue beyond the Participant's Termination of Relationship.

(f) **Restrictive Covenants Generally.** If, at the time of enforcement of the covenants contained in this Section 9.6 (the “**Restrictive Covenants**”), a court shall hold that the duration, scope or area restrictions stated herein are unreasonable under circumstances then existing, the Participant and the Company Group agree that the maximum duration, scope or area reasonable under such circumstances shall be substituted for the stated duration, scope or area and that the court shall be allowed and directed to revise the restrictions contained herein to cover the maximum period, scope and area permitted by applicable law. Each Participant hereby acknowledges that the Restrictive Covenants are reasonable in terms of duration, scope and area restrictions and are necessary to protect the goodwill of the Company Group. Each Participant further acknowledges and agrees that the Restrictive Covenants are being agreed to by such Participant in connection with the Company’s issuance of an Award to such Participant under the Plan, and are in addition to, not in substitution for, any restrictive covenants to which such Participant is or may become subject in connection with any relationship with the Company Group.

(g) **Enforcement.** If any Participant breaches, or threatens to commit a breach of, any of the Restrictive Covenants, the Company Group shall have the following rights and remedies, each of which rights and remedies shall be independent of the others and severally enforceable, and each of which is in addition to, and not in lieu of, any other rights and remedies available to the Company Group at law or in equity: (i) the right and remedy to seek to have the Restrictive Covenants specifically enforced by any court of competent jurisdiction (without posting a bond), it being agreed that any breach or threatened breach of the Restrictive Covenants would cause irreparable injury to the Company Group and that money damages would not provide an adequate remedy to the Company Group; and (ii) the right and remedy to require such Participant to account for and pay over to the Company any profits, monies, accruals, increments or other benefits derived or received by such Participant as the result of any transactions constituting a breach of the Restrictive Covenants. In the event of any breach or violation by any Participant of any of the Restrictive Covenants, the time period of such covenant with respect to such Participant shall, to the fullest extent permitted by law, be tolled until such breach or violation is resolved.

(h) **Forfeiture.** In the event of a material breach by the Participant of any Restrictive Covenant, then in addition to any other remedy which may be available at law or in equity, the Option shall be automatically forfeited effective as of the date on which such violation first occurs, and, in the event that the Participant has previously exercised all or any portion of the Option within the three (3) year period immediately preceding such breach, the Participant shall forfeit such Option Shares without consideration and be required to promptly repay to the Company, upon 10 days prior written demand by the Committee, any proceeds received by the Participant upon disposition of the Option Shares. The foregoing rights and remedies are in addition to any other rights and remedies that may be available to the Company and shall not prevent (and the Participant shall not assert that they shall prevent) the Company from bringing one or more actions in any applicable jurisdiction for injunctive relief or to recover damages as a result of the Participant’s breach of Restrictive Covenants.

## **ARTICLE X**

### **EFFECTIVE DATE OF THE PLAN**

The Plan shall become effective on the date of its adoption by the Board of Directors of the Company (the "Effective Date"); provided, however, that no ISO shall be exercisable by a Participant unless and until the Plan shall have been approved by the Stockholders of the Company in accordance with the provisions of its Certificate of Incorporation and By-laws, which approval shall be obtained by a simple majority vote of Stockholders, voting either in person or by proxy, at a duly held Stockholders' meeting, or by written consent, within twelve months before or after the adoption of the Plan by the Board of Directors (as defined in the LLC Agreement) of the Company.

## **ARTICLE XI**

### **TERMINATION OF THE PLAN**

No Awards may be granted after the Termination Date. Any Awards outstanding as of the Termination Date shall remain in effect in accordance with their applicable terms and conditions and the terms and conditions of the Plan.

## **ARTICLE XII**

### **AMENDMENT OF PLAN**

The Plan may be modified or amended in any respect by the Committee with the prior approval of the Executive Committee (if the Executive Committee is not administering the Plan); provided, however, that the approval of the holders of a majority of the votes that may be cast by all of the holders of Shares to vote (voting together as a single class, with each such holder entitled to cast one vote per Share held by such holder) shall be obtained prior to any such amendment becoming effective if such approval is required by law or is necessary to comply with regulations promulgated by the Commission under Section 16(b) of the Exchange Act or with Section 422 of the Code or the regulations promulgated by the Treasury Department thereunder. Notwithstanding the foregoing, the Plan may not be modified or amended with respect to any existing Award Agreement without the consent of such Participant if such change would materially impair the rights of such Participant.

## **ARTICLE XIII**

### **CAPTIONS**

The use of captions in the Plan is for convenience. The captions are not intended to provide substantive rights.

## ARTICLE XIV

### DISQUALIFYING DISPOSITIONS

If securities acquired by exercise of an ISO granted under the Plan are disposed of within two years following the date of grant of the ISO or one year following the issuance of the securities to the Participant (a “Disqualifying Disposition”), the holder of such securities shall, immediately prior to such Disqualifying Disposition, notify the Company in writing of the date and terms of such Disqualifying Disposition and provide such other information regarding the Disqualifying Disposition as the Company may reasonably require.

## ARTICLE XV

### WITHHOLDING TAXES

Whenever any taxes are required by law to be withheld in connection with Shares delivered to a Participant pursuant to Awards under the Plan (including, without limitation, upon exercise of an NSO (or an exercise of an ISO that will be taxed as an NSO)), such Participant shall remit or, in appropriate circumstances, agree to remit when due, an amount sufficient to satisfy all current or estimated future federal, state, local and foreign withholding tax and employment tax requirements relating thereto. The Committee may, in its sole discretion, allow the Participant to satisfy the withholding tax obligations arising in connection with the delivery of such Shares pursuant to an Award under the Plan by electing to have the Company withhold from the Shares to be issued that number of Shares having a Fair Market Value equal to the amount required to be withheld, determined on the date that the amount of tax to be withheld is determined.

## ARTICLE XVI

### OTHER PROVISIONS

#### **16.1 Other Provisions.**

Each Award granted under the Plan may contain such other terms and conditions not inconsistent with the Plan as may be determined by the Committee, in its sole discretion. Notwithstanding the foregoing, each ISO granted under the Plan shall include those terms and conditions that are necessary to qualify the ISO as an “incentive stock option” within the meaning of Section 422 of the Code and the regulations thereunder and shall not include any terms or conditions that are inconsistent therewith.

#### **16.2 Separability of Provisions.**

If any particular provision of the Plan shall be adjudicated by a court of competent jurisdiction to be invalid, prohibited or unenforceable for any reason, such provision, as to such jurisdiction, shall be ineffective, without invalidating the remaining provisions of the Plan or affecting the validity or enforceability of such provision in any other jurisdiction. Notwithstanding the foregoing, if such provision could be more narrowly drawn so as not to be invalid, prohibited or unenforceable in such jurisdiction, it shall, as to such jurisdiction, be so narrowly drawn, without invalidating the remaining provisions of the Plan or affecting the validity or enforceability of such provision in any other jurisdiction.

**ARTICLE XVII**

**NUMBER AND GENDER**

With respect to words used in the Plan, the singular form shall include the plural form, the masculine gender shall include the feminine gender, and vice-versa, as the context requires.

**ARTICLE XVIII**

**SECTION 409A OF THE CODE**

It is intended that Awards granted under the Plan will not result in the imposition of any tax liability pursuant to Section 409A of the Code. The Plan and each Award Agreement shall be construed and interpreted consistent with that intent. Without limiting the generality of the foregoing and notwithstanding any provision of the Plan to the contrary, if a Participant is a "specified employee" as defined in Section 409A of the Code on such Participant's separation from service (within the meaning of Section 409A of the Code) with the Company, the Participant shall not be entitled to any payments hereunder that would be treated as deferred compensation subject to Section 409A of the Code until the earlier of (i) the date which is six (6) months after his or her separation from service with the Company for any reason other than death and (ii) the date of the Participant's death. Any amounts otherwise payable to the Participant following the Termination of Relationship that are not so paid by reason of this Article XVIII shall be paid as soon as practicable after the date that is six (6) months after the Participant's separation from service with the Company (or, if earlier, the date of the Participant's death). The provisions of this Article XVIII shall apply only if, and to the extent, required to comply with Section 409A of the Code. No provision of the Plan or any Award granted thereunder shall be interpreted or construed to transfer any liability for failure to comply with the requirements of Section 409A from any Participant or any other individual to the Company or any of its Affiliates, employees or agents. Each Participant shall be solely responsible and liable for the satisfaction of all taxes and penalties that may be imposed on or for the account of such Participant in connection with payments and benefits provided in accordance with the terms of the Plan or Award Agreements (including any taxes and penalties under Section 409A of the Code), and in no event whatsoever shall the Company or any of its Affiliates be liable for any additional tax, interest, or penalties that may be imposed on a Participant as a result of Section 409A of the Code or any damages for failing to comply with Section 409A of the Code. For purposes of Section 409A of the Code, each payment that may be made under the Plan or any Award Agreement shall be designated as a separate and distinct payment for purposes under Section 409A of the Code and the applicable Treasury Regulations and guidance promulgated thereunder (including, without limitation, Section 1.409A-1(b)(4)(i)(F), 1.409A-1(b)(9)(iii) and 1.409A-1(b)(9)(v)(B)).

## ARTICLE XIV

### GOVERNING LAW; JURISDICTION; WAIVER OF JURY TRIAL

All questions concerning the construction, interpretation and validity of the Plan and the instruments evidencing the Awards granted hereunder shall be governed by and construed and enforced in accordance with the domestic laws of the State of Delaware, without giving effect to any choice or conflict of law provision or rule (whether in the State of Delaware or any other jurisdiction) that would cause the application of the laws of any jurisdiction other than the State of Delaware. In furtherance of the foregoing, the internal law of the State of Delaware will control the interpretation and construction of the Plan, even if under such jurisdiction's choice of law or conflict of law analysis the substantive law of some other jurisdiction would ordinarily apply.

Each of the Company and, by acceptance of an Award, each Participant irrevocably (i) consents to submit itself, himself or herself to the personal jurisdiction of the Delaware Court of Chancery, or in the event (but only in the event) that the Delaware Court of Chancery does not have subject matter jurisdiction over such legal action or proceeding, the United States District Court for the District of Delaware, or in the event (but only in the event) that such United States District Court for the District of Delaware also does not have subject matter jurisdiction over such legal action or proceeding, any Delaware state court sitting in New Castle County, in connection with any matter based upon or arising out of this Agreement or the actions of the parties hereof, (ii) agrees that it, he, or she will not attempt to deny or defeat such personal jurisdiction by motion or other request for leave from any such court, and (iii) agrees that it, he, or she will not bring any action relating to the Plan, any Award Agreement, or any Award made thereunder in any court other than the courts of the State of Delaware, as described above. Each of the Company and, by acceptance of an Award, each Participant agrees that service of any process, summons, notice or document by U.S. registered mail to the addresses set forth in the applicable Award Agreement, with respect to the Company, and to the addresses set forth in the ledgers of the Company, with respect to any Participant, shall be effective service of process for any suit or proceeding in connection with the Plan, any Award Agreement, or any Award made thereunder. Each of the Company and, by acceptance of an Award, each Participant hereby irrevocably waives, and agrees not to assert, by way of motion, as a defense, counterclaim or otherwise, in any action or proceeding with respect to the Plan, any Award Agreement, or any Award made thereunder, any claim that it is not personally subject to the jurisdiction of the above-named courts for any reason other than the failure to serve process in accordance with this Article XIX, that it or its property is exempt or immune from jurisdiction of any such court or from any legal process commenced in such courts (whether through service of notice, attachment prior to judgment, attachment in aid of execution of judgment, execution of judgment or otherwise), and to the fullest extent permitted by applicable law, that the suit, action or proceeding in any such court is brought in an inconvenient forum, that the venue of such suit, action or proceeding is improper, or that the Plan, any Award Agreement, or any Award made thereunder may not be enforced in or by such courts and further irrevocably waives, to the fullest extent permitted by applicable law, the benefit of any defense that would hinder, fetter or delay the levy, execution or collection of any amount to which the Company or a Participant is entitled pursuant to the final judgment of any court having jurisdiction. Each of the Company and, by acceptance of an Award, each Participant expressly acknowledges that the foregoing waiver is intended to be irrevocable under the laws of the State of Delaware and of the United States of America; provided, that the Company's and any Participant's consent to jurisdiction and service contained in this Article XIX is solely for the purpose referred to in this Article XIX and shall not be deemed to be a general submission to said courts or in the State of Delaware other than for such purpose.



EACH OF THE COMPANY AND, BY ACCEPTANCE OF AN AWARD, EACH PARTICIPANT HEREBY IRREVOCABLY WAIVES ALL RIGHT TO TRIAL BY JURY IN ANY ACTION, PROCEEDING, CLAIM OR COUNTERCLAIM ARISING OUT OF OR RELATING TO THE PLAN, ANY AWARD AGREEMENT, OR ANY AWARD MADE THEREUNDER.

\* \* \* \* \*

**SECOND AMENDED AND RESTATED EMPLOYMENT AGREEMENT**

This Second Amended and Restated Employment Agreement (this "Agreement"), entered into on November 7, 2018, is made by and between Jude Bricker (the "Executive") and SCA Acquisition Holdings, LLC, a Delaware limited liability company (together with any of its subsidiaries and Affiliates (as defined below) as may employ the Executive from time to time, and any and all successors thereto, the "Company").

**RECITALS**

A. The Company and the Executive are parties to that certain Employment Agreement, dated December 13, 2017 (the "Original Employment Agreement"), which was subsequently amended and restated (the "A&R Employment Agreement") and the parties desire to amend and restate the A&R Employment Agreement in its entirety as set forth herein

B. The Company and Executive desire to enter into this Agreement to assure the Company of the exclusive services of the Executive and to set forth the rights and duties of the parties hereto.

C. This Agreement shall supersede any prior agreements or understandings, whether formal or informal, between Executive and the Company or any of its Affiliates, including, without limitation, the Employment Agreement, dated July 3, 2017, by and between the Executive and MN Airlines, LLC (the "Prior Employment Agreement"), the Original Employment Agreement and the A&R Employment Agreement.

**AGREEMENT**

NOW, THEREFORE, in consideration of the foregoing and of the respective covenants and agreements set forth below, the parties hereto agree as follows:

**1. Certain Definitions.**

- (a) "A&R Employment Agreement" shall have the meaning set forth in the recitals hereto.
- (b) "Action" shall have the meaning set forth in Section 9.
- (c) "Affiliate" shall mean, with respect to any Person, any other Person directly or indirectly controlling, controlled by, or under common control with such Person, where "control" shall have the meaning given such term under Rule 405 of the Securities Act of 1933, as amended.
- (d) "Agreement" shall have the meaning set forth in the preamble hereto.
- (e) "Annual Base Salary" shall have the meaning set forth in Section 3(a).
- (f) "Annual Bonus" shall have the meaning set forth in Section 3(b).

(g) “Apollo” means, collectively, the investment funds managed, sponsored or advised by Apollo Management VIII, L.P. A reference to a member of Apollo is a reference to any such investment fund.

(h) “Board” shall mean the Board of Directors of the Company.

(i) The Company shall have “Cause” to terminate the Executive’s employment pursuant to Section 4(a)(iii) hereunder upon (i) the Executive’s indictment for, conviction of, or plea of guilty or nolo contendere to, any (x) felony, (y) misdemeanor involving moral turpitude, or (z) other crime involving either fraud or a breach of the Executive’s duty of loyalty with respect to the Company or any Affiliates thereof, or any of its customers or suppliers, (ii) the Executive’s failure to perform duties as reasonably directed by the Board (other than as a consequence of Disability) after written notice thereof and failure to cure within ten (10) business days of receipt of the written notice, (iii) the Executive’s fraud, misappropriation, embezzlement (whether or not in connection with employment), or material misuse of funds or property belonging to the Company or any of its Affiliates, (iv) the Executive’s willful violation of the policies of the Company or any of its subsidiaries, or gross negligence in connection with the performance of his duties, after written notice thereof and failure to cure within ten (10) business days of receipt of written notice, (v) the Executive’s use of alcohol that interferes with the performance of the Executive’s duties or use of illegal drugs, if either (A) the Executive fails to obtain treatment within ten (10) business days after receipt of written notice thereof or (B) the Executive obtains treatment and, following Executive’s return to work, the Executive’s use of alcohol again interferes with the performance of the Executive’s duties or the Executive again uses illegal drugs (and, for the avoidance of doubt, the Company may place the Executive on unpaid leave during any such treatment, without such occurrence constituting Good Reason), (vi) the Executive’s material breach of this Agreement, and failure to cure such breach within ten (10) business days after receipt of written notice, or (vii) the Executive’s breach of the confidentiality or non-disparagement provisions (excluding unintentional breaches that are cured within ten (10) days after the Executive becomes aware of such breaches, to the extent curable) or the non-competition and non-solicitation provisions to which the Executive is subject (including, without limitation, under Sections 6 and 7 of this Agreement). If, within thirty (30) days subsequent to the Executive’s termination of employment for any reason other than by the Company for Cause, the Company discovers facts such that the Executive’s termination of employment could have been for Cause, the Executive’s termination of employment will be deemed to have been for Cause for all purposes, and the Executive will be required to disgorge to the Company all amounts received under this Agreement, all equity awards or otherwise that would not have been payable to the Executive had such termination of employment been by the Company for Cause.

(i) “Code” shall mean the Internal Revenue Code of 1986, as amended.

(k) “Date of Termination” shall mean (i) if the Executive’s employment is terminated by his death, the date of his death, (ii) if the Executive’s employment is terminated pursuant to Section 4(a)(ii)-(vi); the date specified or otherwise effective pursuant to Section 4(a)(vi), or (iii) if the Executive’s employment is terminated upon expiration of the Term due to either party’s non-renewal in accordance with Section 2(b), the last day of the then-current Term.

(l) “Disability” shall mean the Executive’s incapacitation through any illness, injury, accident or condition of either a physical or psychological nature that has resulted in his inability to perform the essential functions of his position, even with reasonable accommodations, for one hundred eighty (180) calendar days during any period of three hundred sixty-five (365) consecutive calendar days, and such incapacity is expected to continue, as determined by an independent medical examination and evaluated in accordance with the standard used under the Company’s long-term disability insurance policy.

(m) “Executive” shall have the meaning set forth in the preamble hereto.

(n) The Executive shall have “Good Reason” to resign from his employment pursuant to Section 4(a)(v) in the event that any of the following actions are taken by the Company or any of its subsidiaries without his express written consent: (i) a material reduction of Executive’s duties and responsibilities in his capacity as an employee of the Company, (ii) the relocation of the Executive’s principal office location by more than fifty (50) miles from the Minneapolis, Minnesota area (provided that the same materially increases Executive’s commute), (iii) any material breach by the Company of any material term or provision of this Agreement, or (iv) a material reduction in the Executive’s Annual Base Salary; provided, that any such event shall not constitute Good Reason unless and until Executive shall have provided the Company with written notice thereof no later than thirty (30) days following the initial occurrence of such event and the Company shall have failed to fully remedy such event within thirty (30) days of receipt of such notice, and Executive shall have terminated Executive’s employment with the Company within ten (10) days following the expiration of such remedial period.

(o) “Initial Term” shall have the meaning set forth in Section 2(b).

(p) “Inventions” shall have the meaning set forth in Section 7(c)(i).

(q) “MIPA” shall mean the Membership Interest Purchase Agreement, by and among Minnesota Aviation, LLC, the Company and the other parties thereto, dated as of December 13, 2017.

(r) “Notice of Termination” shall have the meaning set forth in Section 4(a)(vi).

(s) “Original Employment Agreement” shall have the meaning set forth in the recitals hereto.

(t) “Person” shall mean an individual, partnership, corporation, limited liability company, business trust, joint stock company, trust, unincorporated association, joint venture, governmental authority, or other entity of whatever nature.

(u) “Prior Employment Agreement” shall have the meaning set forth in the recitals hereto.

(v) “Proprietary Rights” shall have the meaning set forth in Section 7(c)(i).

(w) “Term” shall have the meaning set forth in Section 2(b).

## 2. Employment

(a) In General. The Company shall employ the Executive, and the Executive shall be employed by the Company, for the period set forth in Section 2(b), in the position set forth in Section 2(c), and upon the other terms and conditions herein provided.

(b) Term of Employment. The initial term of employment under this Agreement (the "Initial Term") shall be for the period beginning on the Closing Date (as defined in the MIPA) and ending on the fifth (5th) anniversary of such date, unless earlier terminated as provided in Section 4. The Initial Term shall automatically be extended for successive one (1) year periods (together with the Initial Term, the "Term"), unless either party hereto gives notice of the non-extension of the Term to the other party no later than ninety (90) days prior to the expiration of the then-applicable Term.

### (c) Position and Duties

(i) During the Term, the Executive shall serve as Chief Executive Officer of the Company, with responsibilities, duties, and authority customary for such position. The Executive shall also serve as an officer of Affiliates of the Company as requested by the Board. During each year of the Term, Executive will be nominated to serve as a member of the Board, subject to shareholder approval of such nomination. The Executive shall not be entitled to any additional compensation for his service as a member of the Board or other positions or titles he may hold with any Affiliate of the Company to the extent he is so appointed. The Executive shall report to the Board. The Executive agrees to observe and comply with the Company's rules and policies as adopted from time to time by the Company. The Executive shall devote his full business time, skill, attention, and best efforts to the performance of his duties hereunder; provided, however, that the Executive shall be entitled to (A) serve on civic, charitable, and religious boards, (B) subject in each case to approval by the Board, serve on corporate boards, and (C) manage the Executive's personal and family investments, in each case, to the extent that such activities do not interfere with the performance of the Executive's duties and responsibilities hereunder, are not in conflict with the business interests of the Company or its Affiliates, and do not compete with the business of the Company or its Affiliates. During the Term, the Executive shall submit to the Board all business, commercial and investment opportunities or offers presented to the Executive or of which the Executive becomes aware which relate to the business of the Company and its Affiliates at any time during the Term, and unless approved by the Board, the Executive shall not accept or pursue, directly or indirectly, any such corporate opportunities on the Executive's own behalf.

(ii) The Executive's employment shall be principally based at the Company's headquarters in the Minneapolis, Minnesota area. The Executive shall perform his duties and responsibilities to the Company at such principal place of employment and at such other location(s) to which the Company may reasonably require the Executive to travel for Company business purposes.

### 3. Compensation and Related Matters.

(a) Annual Base Salary. During the Term, the Executive shall receive a base salary at a rate of two hundred thousand dollars (\$200,000) per annum, which shall be paid in accordance with the customary payroll practices of the Company (the "Annual Base Salary").

(b) Annual Bonus. With respect to each calendar year that ends during the Term, (i) only if the Loan (as defined below) is outstanding during such applicable calendar year, the Executive shall receive a non-discretionary annual cash bonus of sixty thousand dollars (\$60,000) (the "Non-Discretionary Annual Bonus"), and (ii) the Executive shall be eligible to receive a discretionary annual cash bonus with a target amount equal to two-hundred percent (200%) of the Annual Base Salary (the "Discretionary Annual Bonus," and, together with the Non-Discretionary Annual Bonus, the "Annual Bonus"). The Executive's actual Discretionary Annual Bonus for a given year, if any, shall be determined on the basis of the Executive's and/or the Company's attainment of objective financial and/or other subjective or objective criteria established by the Board and communicated to the Executive at the beginning of such year. Each such Annual Bonus shall be payable on such date as is determined by the Board, but in any event within the period required by Section 409A of the Code such that it qualifies as a "short-term deferral" pursuant to Section 1.409A-1(b)(4) of the Department of Treasury Regulations (or any successor thereto). Notwithstanding the foregoing, no Annual Bonus shall be payable with respect to any calendar year unless the Executive remains continuously employed with the Company through the date of payment, except as otherwise provided in Section 5.

(c) Equity.

(i) As soon as reasonably practicable following the Closing Date, the Executive shall be granted an option to purchase shares of common stock of the Company equal to 3.0% of the fully diluted total outstanding shares of the Company, subject to the terms and conditions set forth in the Company's equity incentive plan and a nonqualified stock option agreement thereunder.

(ii) As soon as reasonably practicable following the Closing Date, the Executive shall purchase \$7,000,000 of shares of Company common stock at the same indicative price per share that is paid by Apollo (the "Purchased Interests") (as an illustrative matter, the percentage of the Company's equity account represented by the Purchased Interests is set forth on Exhibit A hereto, assuming current expectations), subject to the Executive becoming a party to the Company's investor rights agreement. In connection with such purchase, the Company shall issue a loan to the Executive in exchange for a promissory note to be executed by the Executive on the following terms (the "Loan");

(A) Original Principal Amount: \$2,500,000.

(B) Interest Rate: 2.09% per annum; interest shall accrue quarterly in arrears and be payable quarterly in cash.

(C) Maturity: five years from issuance date, subject to acceleration as provided below.

(D) Collateral: the Loan shall be full recourse and shall be secured by the Purchased Interests and all other equity interests of the Company held by the Executive.

(E) Prepayment: prepayable without penalty at any time upon the election of the Executive. In addition, until repayment in full, any amounts received as cash dividends on the Purchased Interests, as adjusted for taxes, shall be used for prepayment of the Loan.

(F) Acceleration: the Loan shall be repayable in full upon the earliest of the following dates: (i) the date that is 10 business days following termination of Executive's service to the Company or its Affiliates by the Company for Cause or due to Executive's resignation without Good Reason, or (ii) the date of the consummation of a sale or change in control that results in a monetization event for the Purchased Interests. For the avoidance of doubt, the Loan shall not accelerate upon the Executive's termination of service for any reason other than by the Company for Cause or due to Executive's resignation without Good Reason.

(d) Executive Travel Benefits. The Executive is entitled to both positive-space and space-available travel benefits, in accordance with the Company's rules and policies.

(i) Positive Space Travel. Positive space travel is permitted as follows: the Executive will receive an annual credit of \$15,000 in the Executive's Universal Air Travel Plan ("UATP") account for personal travel on Company scheduled flights for the Executive and certain Qualifying Friends and Family (as defined below). Each flown segment is valued at \$75, and deducted from the UATP account. The value of this benefit is reported as taxable income with taxes on such income paid for by the Company.

(ii) Qualifying Friends & Family. "Qualifying Friends and Family" are defined as follows:

(A) If the Executive travels on a flight itinerary, the Executive may bring up to eight friends or family members, on the same itinerary, on any scheduled Company flight (provided such persons are not prohibited by Company from traveling on Company flights).

(B) If the Eligible Executive is not listed on the flight itinerary, i) the Executive's Circle Of Travelers (defined under the Company's Employee Travel Policy) may use the Executive's positive travel benefit for any scheduled Company flight and flown segments will be deducted from the UATP account; or ii) any friend or family member not otherwise prohibited by Company from traveling on Company's flights, may travel to and/or from the Executive's then-present location or homestead, to visit the Executive and/or Executive's family.

(iii) Space Available Travel. The Executive and the Executive's Circle Of Travelers may also travel on scheduled Company flights in accordance with the Company's Employee Travel Policy, in which case, flown segments will not be deducted from the Executive's UATP account.

(iv) Vesting. Upon the earlier of (x) five (5) years from April 11, 2018, or (y) a Change in Control (as defined in the Equity Plan), Executive's travel benefits under this Section 3(d) shall vest for the Executive's lifetime and therefore be useable by Executive for the remainder of Executive's life. The terms related to the Company's policies shall be defined as the terms were defined the day before the execution of any agreement or event that would trigger the vesting described here.

(e) Benefits. During the Term, the Executive shall be entitled to participate in the employee benefit plans, programs, and arrangements of the Company as may be in effect from time to time, in accordance with their terms.

(f) Vacation. During the Term, the Executive shall be entitled to vacation in accordance with the Company's vacation policies, as then in effect. Any vacation shall be taken at a time that does not unreasonably interfere with the Executive's work and the Company's operations.

(g) Business Expenses. During the Term, the Company shall reimburse the Executive for all reasonable travel and other business expenses incurred by him in the performance of his duties to the Company, in accordance with the Company's expense reimbursement policies and procedures.

(h) Long Term Incentive Bonus. During the Term, the Executive shall be entitled to participate in the Company's then-prevailing long-term incentive plan ("Long-Term Incentive"). The Executive's actual Long-Term Incentive for a given year, if any, shall be determined on the basis of the Executive's and/or the Company's attainment of objective financial and/or other subjective or objective criteria established by the Board and communicated to the Executive at the beginning of such year. Each such Long-Term Incentive shall be payable on such date as is determined by the Board, but in any event within the period required by Section 409A of the Code such that it qualifies as a "short-term deferral" pursuant to Section 1.409A-1(b)(4) of the Department of Treasury Regulations (or any successor thereto). Notwithstanding the foregoing, no Long-Term Incentive shall be payable with respect to any calendar year unless the Executive remains continuously employed with the Company through the date of payment, except as otherwise provided in Section 5.

4. Termination. Prior to the expiration of the Term resulting from a non-renewal pursuant to Section 2(b) above, the Executive's employment hereunder may be terminated without any breach of this Agreement only under the following circumstances:

(a) Circumstances.

(i) Death. The Executive's employment hereunder shall terminate upon his death.



(ii) Disability. If the Executive has incurred a Disability, the Company may give the Executive written notice of its intention to terminate the Executive's employment. In that event, the Executive's employment with the Company shall terminate effective on the later of the thirtieth (30th) day after receipt of such notice by the Executive and the date specified in such notice, provided that within the thirty (30) day period following receipt of such notice, the Executive shall not have returned to full-time performance of his duties hereunder.

(iii) Termination with Cause. The Company may terminate the Executive's employment with Cause.

(iv) Termination without Cause. The Company may terminate the Executive's employment without Cause.

(v) Resignation with Good Reason. The Executive may resign from his employment with Good Reason.

(vi) Resignation without Good Reason. The Executive may resign from his employment without Good Reason upon not less than sixty (60) days' advance written notice to the Board.

(b) Notice of Termination. Any termination of the Executive's employment by the Company or by the Executive under this Section 4 (other than termination pursuant to Section 4(a)(i)) shall be communicated by a written notice to the other party hereto (i) indicating the specific termination provision in this Agreement relied upon, (ii) except with respect to a termination pursuant to Section 4(a)(iv) or (vi), setting forth in reasonable detail the facts and circumstances claimed to provide a basis for termination of the Executive's employment under the provision so indicated, and (iii) specifying a Date of Termination as provided herein (a "Notice of Termination"). If the Company delivers a Notice of Termination under Section 4(a)(ii), the Date of Termination shall be at least sixty (60) days following the date of such notice; provided, however, that such notice need not specify a Date of Termination, in which case the Date of Termination shall be determined pursuant to Section 4(a)(ii). If the Company delivers a Notice of Termination under Section 4(a)(iii) or 4(a)(iv), the Date of Termination shall be, in the Company's sole discretion, the date on which the Executive receives such notice or any subsequent date selected by the Company. If the Executive delivers a Notice of Termination under Section 4(a)(v) in accordance with the definition of Good Reason, the Date of Termination shall be determined in accordance with the provisions of such definition. If the Executive delivers a Notice of Termination under Section (a)(vi), the Date of Termination shall be at least sixty (60) days following the date of such notice; provided, however, in each case, that the Company may, in its sole discretion, accelerate the Date of Termination to any date that occurs following the Company's receipt of such notice, without changing the characterization of such termination as voluntary, even if such date is prior to the date specified in such notice and without having to pay any compensation or benefits for the balance of such notice period. The failure by the Company or the Executive to set forth in the Notice of Termination any fact or circumstance that contributes to a showing of Cause or Good Reason shall not waive any right of the Company or the Executive hereunder or preclude the Company or the Executive from asserting such fact or circumstance in enforcing the Company's or the Executive's rights hereunder.

(c) Termination of All Positions. Upon termination of the Executive's employment for any reason, the Executive agrees to resign, as of the Date of Termination or such other date requested by the Company, from all positions and offices that the Executive then holds with the Company and its Affiliates. The Executive agrees to promptly execute such documents as the Company, in its sole discretion, shall reasonably deem necessary to effect such resignations, and in the event that the Executive is unable or unwilling to execute any such document, Executive hereby grants his proxy to any officer of the Company to so execute on his behalf.

(d) Suspension of Duties. The Company reserves the right to bar the Executive from the offices of the Company or any of its Affiliates and to require that the Executive refrain from undertaking all or any of the Executive's duties and contacting clients, colleagues and advisors of the Company or any of its Affiliates (unless otherwise instructed) during all or part of any period of notice of Executive's termination of employment. Should the Company exercise this right, all the Executive's other duties and obligations hereunder, including the Executive's duties of fidelity and confidentiality to the Company, remain in full force and effect and, during any such period, the Executive shall remain a service provider to the Company and shall not be employed or engaged in any other business. For the avoidance of doubt, the Company shall continue to pay to the Executive the Annual Base Salary and to provide health and welfare benefits during any such notice period, until the Date of Termination.

#### 5. Company Obligations upon Termination of Employment.

(a) In General. Subject to Section IO(a), upon termination of the Executive's employment for any reason, the Executive (or the Executive's estate) shall be entitled to receive (i) any amount of the Executive's Annual Base Salary earned through the Date of Termination not theretofore paid, (ii) any Annual Bonus (and if applicable, any Long-Term Incentive) for the year prior to the year in which the Date of Termination occurred, that was earned but not yet paid, (iii) any expenses owed to the Executive under Section 3(f), and (iv) any amount arising from the Executive's participation in, or benefits under, any employee benefit plans, programs, or arrangements under Section 3(d) (other than severance plans, programs, or arrangements), which amounts shall be payable in accordance with the terms and conditions of such employee benefit plans, programs, or arrangements including, where applicable, any death and disability benefits (the "Accrued Obligations"). Notwithstanding anything to the contrary, upon a termination by the Company with Cause or due to Executive's resignation without Good Reason, the Accrued Obligations shall not include the amount set forth in clause (ii) of the preceding sentence.

(b) Termination without Cause, Resignation with Good Reason or Non-Renewal by the Company. Subject to Section IO(a) and subject to the Executive's continued compliance with the covenants contained in Sections 6 and 7, if the Company terminates the Executive's employment without Cause pursuant to Section 4(a)(iv), the Executive resigns from his employment with Good Reason pursuant to Section 4(a)(v), or the Company elects not to renew the Term pursuant to Section 2(b), the Company shall, in addition to the Accrued Obligations, continue to pay the Annual Base Salary in accordance with the Company's customary payroll practices during the period beginning on the Date of Termination and ending on the earlier to occur of (A) the eighteen (18) month anniversary of the Date of Termination and (B) the first date that the Executive violates any covenant contained in Section 6 or 7, after receipt of written

notice thereof and expiration of a 10 business day cure period; provided, however, the installment payments payable pursuant to this Section 5(b) shall commence on the first payroll period following the effective date of the Release (as defined below), and the initial installment shall include a lump-sum payment of all amounts accrued under this Section 5(b) from the Date of Termination through the date of such initial payment.

(c) Release. Notwithstanding anything herein to the contrary, the amounts payable to the Executive under Sections 5(b), other than the Accrued Obligations, shall be contingent upon and subject to the Executive's (or the Executive's estate, if applicable) execution and non-revocation of a general waiver and release of claims agreement in the Company's customary form (the "Release") (and the expiration of any applicable revocation period), on or prior to the sixtieth (60<sup>th</sup>) day following the Date of Termination.

(d) Survival. The expiration or termination of the Term shall not impair the rights or obligations of any party hereto, which shall have accrued prior to such expiration or termination.

6. Non-Competition; Non-Solicitation; Non-Hire.

(a) To the fullest extent permitted by applicable law, the Executive agrees that during the Executive's employment with the Company, and for the eighteen (18) month period following the Executive's termination of employment for any reason, the Executive will not, directly or indirectly, engage in, have any equity or equity-based interest in, or manage or operate any Person, firm, corporation, partnership, business or entity (whether as director, officer, employee, agent, representative, partner, security holder, consultant, or otherwise) that engages in (either directly or through any subsidiary or Affiliate thereof) any business or activity that competes with any of the businesses of the Company or any entity owned by the Company (including, without limitation, any United States regional air carrier or any non-mainline carrier in Mexico, Canada or the Caribbean). Notwithstanding the foregoing, the Executive shall be permitted to acquire a passive stock or equity interest in such a business, provided that the stock or other equity interest acquired is not more than one percent (1%) of the outstanding interest in such business;

(b) To the fullest extent permitted by applicable law, the Executive agrees that during the Executive's employment with the Company, and for the eighteen (18) month period following the Executive's termination of employment for any reason, the Executive will not, directly or indirectly, on the Executive's own behalf or on behalf of another (i) solicit, induce or attempt to solicit or induce any officer, director or employee of the Company to terminate their relationship with or leave the employ of the Company, or in any way interfere with the relationship between the Company, on the one hand, and any officer, director or employee thereof, on the other hand, (ii) hire (or other similar arrangement) any Person (in any capacity whether as an officer, director, employee or consultant) who is or at any time was an officer, director or employee of the Company until twelve (12) months after such individual's relationship (whether as an officer, director or employee) with the Company has ended, or (iii) induce or attempt to induce any customer, supplier, prospect, licensee or other business relation of the Company to cease doing business with the Company, or in any way interfere with the relationship between any such customer, supplier, prospect, licensee or business relation, on the one hand, and the Company, on the other hand; provided, that it shall not be a violation of this

Section 6(b) for a subsequent employer of the Executive to hire a Company employee who is at the “director” level or below, so long as such Company employee responds to generic, non-targeted position advertising and the Executive does not engage in activities prohibited by clause (i) of this Section 6(b) with respect to such Company employee.

(c) In the event that the terms of this Section 6 shall be determined by any court of competent jurisdiction to be unenforceable by reason of its extending for too great a period of time or over too great a geographical area or by reason of its being too extensive in any other respect, it will be interpreted to extend only over the maximum period of time for which it may be enforceable, over the maximum geographical area as to which it may be enforceable, or to the maximum extent in all other respects as to which it may be enforceable, all as determined by such court in such action. The Executive hereby acknowledges that the terms of this Section 6 are reasonable in terms of duration, scope and area restrictions and are necessary to protect the goodwill of the Company. The Executive hereby authorizes the Company to inform any future employer or prospective employer of the existence and terms of Sections 6 and 7 of this Agreement without liability for interference with the Executive’s employment or prospective employment.

(d) The Executive acknowledges that the Company has expended and shall continue to expend substantial amounts of time, money and effort to develop business strategies, employee and customer relationships and goodwill and build an effective organization. The Executive recognizes and acknowledges that he has access to confidential information and trade secrets, and has had or will have material contact with the Company’s customers, suppliers, licensees, representatives, agents, partners, licensors, or business relations, and that the Executive’s services are of special, unique and extraordinary value to the Company and its Affiliates. The Executive acknowledges that the Company has a legitimate business interest and right in protecting its confidential information, business strategies, employee and customer relationships and goodwill, and that the Company would be seriously damaged by the disclosure of confidential information and the loss or deterioration of its business strategies, employee and customer relationships and goodwill. The Executive acknowledges (i) that the business of the Company and its Affiliates is international in scope and without geographical limitation and (ii) notwithstanding the jurisdiction of formation or principal office of the Company and its Affiliates, or the location of any of their respective executives or employees (including, without limitation, the Executive), it is expected that the Company and its Affiliates will have business activities and have valuable business relationships within their respective industries throughout the world. The Executive further acknowledges that although his compliance with the covenants contained in Sections 6 and 7 may prevent the Executive from earning a livelihood in a business similar to the business of the Company, the Executive’s experience and capabilities are such that the Executive has other opportunities to earn a livelihood and adequate means of support for the Executive and the Executive’s dependents. In addition, the Executive agrees and acknowledges that the potential harm to the Company of the non-enforcement of Sections 6 and 7 outweighs any potential harm to the Executive of their enforcement by injunction or otherwise.

(e) As used in this Section 6, the term “Company” shall include the Company, and any direct or indirect subsidiaries thereof or any successors thereto.

7. Nondisclosure of Confidential Information; Nondisparagement; Intellectual Property.

(a) Non-Disclosure of Confidential Information; Return of Property. Except as required in the faithful performance of the Executive's duties hereunder, Executive agrees that during the Term and in perpetuity thereafter, the Executive shall maintain in confidence and shall not directly, indirectly or otherwise, use, disseminate, disclose or publish, or use for the Executive's benefit or the benefit of any Person, any confidential or proprietary information or trade secrets of or relating to the Company, including, without limitation, information with respect to the Company's operations, processes, products, inventions, business practices, finances, principals, vendors, suppliers, customers, potential customers, marketing methods, costs, prices, contractual relationships, regulatory status, compensation paid to employees or other terms of employment, or deliver to any Person any document, record, notebook, computer program or similar repository of or containing any such confidential or proprietary information or trade secrets. Confidential Information shall not include any information that is generally known to the industry or the public other than as a result of the Executive's breach of this covenant or any breach of other confidentiality obligations by third parties. Upon the Executive's termination of employment for any reason, the Executive shall promptly deliver to the Company all correspondence, drawings, manuals, letters, notes, notebooks, reports, programs, plans, proposals, financial documents, or any other documents concerning the Company's customers, business plans, marketing strategies, products or processes. The Executive may respond to a lawful and valid subpoena or other legal process but shall give the Company the earliest possible notice thereof, shall, as much in advance of the return date as possible, make available to the Company and its counsel the documents and other information sought and, if requested by the Company, shall reasonably assist such counsel in resisting or otherwise responding to such process.

(b) Non-Disparagement. The Executive shall not, at any time during the Term and in perpetuity thereafter, directly or indirectly, knowingly disparage, criticize, or otherwise make derogatory statements regarding the Company and its officers, the members of the Board, and the respective Affiliates of any of the foregoing. The foregoing shall not be violated by the Executive's truthful responses to legal process or inquiry by a governmental authority.

(c) Intellectual Property Rights.

(i) The Executive agrees that the results and proceeds of the Executive's services for the Company (including, but not limited to, any trade secrets, products, services, processes, know-how, designs, developments, innovations, analyses, drawings, reports, techniques, formulas, methods, developmental or experimental work, improvements, discoveries, inventions, ideas, source and object codes, programs, matters of a literary, musical, dramatic or otherwise creative nature, writings and other works of authorship) resulting from services performed for the Company and any works in progress, whether or not patentable or registrable under copyright or similar statutes, that were made, developed, conceived or reduced to practice or learned by the Executive, either alone or jointly with others (collectively, "Inventions"), shall be works-made-for-hire and the Company (or, if applicable or as directed by the Company) shall be deemed the sole owner throughout the universe of any and all trade secret, patent, copyright and other intellectual property rights (collectively, "Proprietary Rights") of whatsoever nature therein, whether or not now or hereafter known, existing, contemplated, recognized or developed, with the right to use the same in perpetuity in any manner the Company determines in its sole discretion, without any further payment to the Executive whatsoever. If, for any reason,

any of such results and proceeds shall not legally be a work-made-for-hire and/or there are any Proprietary Rights which do not accrue to the Company under the immediately preceding sentence, then the Executive hereby irrevocably assigns and agrees to assign any and all of the Executive's right, title and interest thereto, including, without limitation, any and all Proprietary Rights of whatsoever nature therein, whether or not now or hereafter known, existing, contemplated, recognized or developed, to the Company (or, if applicable or as directed by the Company, any of its Affiliates), and the Company or such Affiliates shall have the right to use the same in perpetuity throughout the universe in any manner determined by the Company or such Affiliates without any further payment to the Executive whatsoever. As to any Invention that the Executive is required to assign, the Executive shall promptly and fully disclose to the Company all information known to the Executive concerning such Invention. The Executive hereby waives and quitclaims to the Company any and all claims, of any nature whatsoever, that the Executive now or may hereafter have for infringement of any Proprietary Rights assigned hereunder to the Company. In accordance with applicable law, this section 7(c) does not apply to any Inventions for which no equipment, supplies, facilities, trade secrets or other Confidential Information of the Company was used and which was developed entirely on the Executive's own time unless (a) the Invention relates to the Company's business or the Company's actual or demonstrably anticipated research or development; or (b) the Invention results from any work performed by the Executive for the Company.

(ii) The Executive agrees that, from time to time, as may be requested by the Company and at the Company's sole cost and expense, the Executive shall do any and all things that the Company may reasonably deem useful or desirable to establish or document the Company's exclusive ownership throughout the United States of America or any other country of any and all Proprietary Rights in any such Inventions, including, without limitation, the execution of appropriate copyright and/or patent applications or assignments. To the extent the Executive has any Proprietary Rights in the Inventions that cannot be assigned in the manner described above, the Executive unconditionally and irrevocably waives the enforcement of such Proprietary Rights. This Section 7(c)(ii) is subject to and shall not be deemed to limit, restrict or constitute any waiver by the Company of any Proprietary Rights of ownership to which the Company may be entitled by operation of law by virtue of the Executive's employment with, or service to, the Company. The Executive further agrees that, from time to time, as may be requested by the Company and at the Company's sole cost and expense, the Executive shall assist the Company in every proper and lawful way to obtain and from time to time enforce Proprietary Rights relating to Inventions in any and all countries. To this end, the Executive shall execute, verify and deliver such documents and perform such other acts (including appearances as a witness) as the Company may reasonably request for use in applying for, obtaining, perfecting, evidencing, sustaining, and enforcing such Proprietary Rights and the assignment thereof. In addition, the Executive shall execute, verify, and deliver assignments of such Proprietary Rights to the Company or its designees. The Executive's obligation to assist the Company with respect to Proprietary Rights relating to such Inventions in any and all countries shall continue beyond the termination of the Executive's employment with the Company.

(d) Prior Employment Information. The Executive further agrees that the Executive will not improperly use or disclose any confidential information or trade secrets, if any, of any former employers or any other Person to whom the Executive has an obligation of confidentiality, and will not bring onto the premises of the Company or its Affiliates any unpublished documents or any property belonging to any former employer or any other Person to whom the Executive has an obligation of confidentiality unless consented to in writing by the former employer or other Person.

(e) Notwithstanding anything to the contrary contained in this Agreement, (i) the Executive will not be held criminally or civilly liable under any federal or state trade secret law for any disclosure of a trade secret that is made: (A) in confidence to a federal, state, or local government official, either directly or indirectly, or to an attorney; and (B) solely for the purpose of reporting or investigating a suspected violation of law; or is made in a complaint or other document that is filed under seal in a lawsuit or other proceeding, and (ii) nothing in this Agreement shall prohibit Executive from reporting possible violations of federal law or regulation to or otherwise cooperating with or providing information requested by any governmental agency or entity, including, but not limited to, the Department of Justice, the Securities and Exchange Commission, the Congress, and any agency Inspector General, or making other disclosures that are protected under the whistleblower provisions of federal law or regulation. The Executive does not need the prior authorization of the Company to make any such reports or disclosures and the Executive is not required to notify the Company that the Executive has made such reports or disclosures. If the Executive files a lawsuit for retaliation by the Company for reporting a suspected violation of law, the Executive may disclose the Company's trade secrets to the Executive's attorney and use the trade secret information in the court proceeding if the Executive: (x) files any document containing the trade secret under seal; and (y) does not disclose the trade secret, except pursuant to court order.

(f) As used in this Section 7, the term "Company" shall include the Company, and any direct or indirect subsidiaries thereof or any successors thereto.

8. Injunctive Relief. The Executive recognizes and acknowledges that a breach of any of the covenants contained in Sections 6 and 7 may cause irreparable damage to the Company and its goodwill, the exact amount of which may be difficult or impossible to ascertain, and that the remedies at law for any such breach may be inadequate. Accordingly, the Executive agrees that in the event of a breach or threatened breach of any of the covenants contained in Sections 6 and 7, in addition to any other remedy that may be available at law or in equity, the Company will be entitled (without the necessity of showing economic loss or other actual damage) to specific performance and injunctive relief (without posting a bond). In the event of any breach or violation by the Executive of any of the covenants contained in Section 6 and 7, the time period of such covenant with respect to the Executive shall, to the fullest extent permitted by law, be tolled until such breach or violation is resolved.

9. Cooperation. The Executive agrees that during and after his employment with the Company, the Executive will assist the Company and its Affiliates in the defense of any claims or potential claims that may be made or threatened to be made against the Company or any of its Affiliates in any action, suit, or proceeding, whether civil, criminal, administrative, investigative, or otherwise (each, an "Action"), and will assist the Company and its Affiliates in the prosecution of any claims that may be made by the Company or any of its Affiliates in any Action, to the extent that such claims may relate to the Executive's employment or the period of the Executive's employment by the Company and its Affiliates. The Executive agrees, unless precluded by law, to promptly inform the Company if the Executive is asked to participate (or

otherwise become involved) in any such Action. The Executive also agrees, unless precluded by law, to promptly inform the Company if the Executive is asked to assist in any investigation (whether governmental or otherwise) of the Company or any of its Affiliates (or their actions) to the extent that such investigation may relate to the Executive's employment or the period of the Executive's employment by the Company, regardless of whether a lawsuit has then been filed against the Company or any of its Affiliates with respect to such investigation. The Company or one of its Affiliates shall reimburse the Executive for all of the Executive's reasonable out-of-pocket expenses associated with such cooperation following his Date of Termination.

#### 10. Section 409A of the Code.

(a) General. The parties hereto acknowledge and agree that, to the extent applicable, this Agreement shall be interpreted in accordance with, and incorporate the terms and conditions required by, Section 409A of the Code and the Department of Treasury Regulations and other interpretive guidance issued thereunder, including without limitation any such regulations or other guidance that may be issued after the date hereof. Notwithstanding any provision of this Agreement to the contrary, in the event that the Company determines that any amounts payable hereunder will be taxable currently to the Executive under Section 409A(a)(1)(A) of the Code and related Department of Treasury guidance, the Company and the Executive shall cooperate in good faith to (i) adopt such amendments to this Agreement and appropriate policies and procedures, including amendments and policies with retroactive effect, that they mutually determine to be necessary or appropriate to preserve the intended tax treatment of the benefits provided by this Agreement, to preserve the economic benefits of this Agreement, and to avoid less-favorable accounting or tax consequences for the Company, and/or (ii) take such other actions as mutually determined to be necessary or appropriate to exempt the amounts payable hereunder from Section 409A of the Code or to comply with the requirements of Section 409A of the Code and thereby avoid the application of penalty taxes thereunder; provided, however, that this Section 10(a) does not create an obligation on the part of the Company to modify this Agreement and does not guarantee that the amounts payable hereunder will not be subject to interest or penalties under Section 409A, and in no event whatsoever shall the Company or any of its Affiliates be liable for any additional tax, interest, or penalties that may be imposed on the Executive as a result of Section 409A of the Code or any damages for failing to comply with Section 409A of the Code.

(b) Separation from Service under Section 409A. Notwithstanding any provision to the contrary in this Agreement: (i) no amount that is "nonqualified deferred compensation" subject to Section 409A of the Code shall be payable pursuant to Section 5 unless the termination of the Executive's employment constitutes a "separation from service" within the meaning of Section 1.409A-1(h) of the Department of Treasury Regulations; (ii) if the Executive is deemed at the time of his separation from service to be a "specified employee" for purposes of Section 409A(a)(2)(B)(i) of the Code, to the extent that delayed commencement of any portion of the termination benefits to which the Executive is entitled under this Agreement (after taking into account all exclusions applicable to such termination benefits under Section 409A), including, without limitation, any portion of the additional compensation awarded pursuant to Section 5, is required in order to avoid a prohibited distribution under Section 409A(a)(2)(B)(i) of the Code, such portion of the Executive's termination benefits shall not be provided to the Executive prior to the earlier of (A) the expiration of the six-month period measured from the date of the



Executive's "separation from service" with the Company (as such term is defined in the Department of Treasury Regulations issued under Section 409A) and (B) the date of the Executive's death; provided, that upon the earlier of such dates, all payments deferred pursuant to this Section 11(b)(ii) shall be paid to the Executive in a lump sum, and any remaining payments due under this Agreement shall be paid as otherwise provided herein; (iii) the determination of whether the Executive is a "specified employee" for purposes of Section 409A(a)(2)(B)(i) of the Code as of the time of his separation from service shall be made by the Company in accordance with the terms of Section 409A of the Code and applicable guidance thereunder (including, without limitation, Section 1.409A-1(i) of the Department of Treasury Regulations and any successor provision thereto); (iv) for purposes of Section 409A of the Code, the Executive's right to receive installment payments pursuant to Section 5 shall be treated as a right to receive a series of separate and distinct payments; (v) if the sixty day period following the Date of Termination ends in the calendar year following the year that includes the Date of Termination, then payment of any amount that is conditioned upon the execution of the Release and is subject to Section 409A shall not be paid until the first day of the calendar year following the year that includes the Date of Termination, regardless of when the Release is signed; and (vi) to the extent that any reimbursement of expenses or in-kind benefits constitutes "deferred compensation" under Section 409A, such reimbursement or benefit shall be provided no later than December 31 of the year following the year in which the expense was incurred. The amount of expenses reimbursed in one year shall not affect the amount eligible for reimbursement in any subsequent year. The amount of any in-kind benefits provided in one year shall not affect the amount of in-kind benefits provided in any other year. The right to any benefits or reimbursements or in-kind benefits may not be liquidated or exchanged for any other benefit.

#### 11. Section 280G of the Code.

(a) If there is a change of ownership or effective control or change in the ownership of a substantial portion of the assets of a corporation (within the meaning of Section 280G of the Code) and any payment or benefit (including payments and benefits pursuant to this Agreement) that the Executive would receive from the Company or otherwise ("Transaction Payment") would (i) constitute a "parachute payment" within the meaning of Section 280G of the Internal Revenue Code of 1986 (the "Code"), and (ii) but for this sentence, be subject to the excise tax imposed by Section 4999 of the Code (the "Excise Tax"), then the Company shall cause to be determined, before any amounts of the Transaction Payment are paid to the Executive, which of the following two alternative forms of payment would result in the Executive's receipt, on an after-tax basis, of the greater amount of the Transaction Payment notwithstanding that all or some portion of the Transaction Payment may be subject to the Excise Tax: (x) payment in full of the entire amount of the Transaction Payment (a "Full Payment"), or (y) payment of only a part of the Transaction Payment so that the Executive receives the largest payment possible without the imposition of the Excise Tax (a "Reduced Payment"). For purposes of determining whether to make a Full Payment or a Reduced Payment, the Company shall cause to be taken into account all applicable federal, state and local income and employment taxes and the Excise Tax (all computed at the highest applicable marginal rate, net of the maximum reduction in federal income taxes which could be obtained from a deduction of such state and local taxes). If a Reduced Payment is made, the reduction in payments and/or benefits will occur in the following order: (1) cash payments (from latest scheduled to earliest scheduled); (2) any equity

or equity derivatives that are included under Section 280G of the Code at full value rather than accelerated value (with the highest value reduced first); and (3) any equity or equity derivatives included under Section 280G of the Code at an accelerated value (and not at full value), with the highest value reduced first (as such values are determined under Treasury Regulation Section 1.280G-1, Q&A 24); and (4) any other non-cash benefits (from latest scheduled to earliest scheduled).

(b) Unless the Executive and the Company otherwise agree in writing, any determination required under this section shall be made in writing by the Company's independent public accountants (the "Accountants"), whose determination shall be conclusive and binding upon the Executive and the Company for all purposes. For purposes of making the calculations required by this section, the Accountants may make reasonable assumptions and approximations concerning applicable taxes and may rely on reasonable, good faith interpretations concerning the application of Sections 280G and 4999 of the Code. The Accountants shall provide detailed supporting calculations to the Company and the Executive as requested by the Company or the Executive. The Executive and the Company shall furnish to the Accountants such information and documents as the Accountants may reasonably request in order to make a determination under this section. The Company shall bear all costs the Accountants may reasonably incur in connection with any calculations contemplated by this Section 11(b).

(c) Notwithstanding the foregoing, in the event that no stock of the Company or its Affiliates is readily tradable on an established securities market or otherwise (within the meaning of Section 280G of the Code) at the time of the change in control, the Board may elect to submit to a vote of shareholders for approval the portion of the Transaction Payments that equals and exceeds three times the Executive's "base amount" (within the meaning of Section 280G of the Code) (the "Excess Parachute Payments") in accordance with Treas. Reg. §1.280G-1, and the Executive shall cooperate with such vote of shareholders, including the execution of any required documentation subjecting the Executive's entitlement to all Excess Parachute Payments to such shareholder vote.

12. Assignment and Successors. The Company may assign its rights and obligations under this Agreement to any entity, including any successor to all or substantially all the assets of the Company, by merger or otherwise, and may assign or encumber this Agreement and its rights hereunder as security for indebtedness of the Company and its Affiliates. The Executive may not assign his rights or obligations under this Agreement to any individual or entity. This Agreement shall be binding upon and inure to the benefit of the Company and the Executive and their respective successors, assigns, personnel, legal representatives, executors, administrators, heirs, distributees, devisees, and legatees, as applicable. In the event of the Executive's death following a termination of his employment, all unpaid amounts otherwise due the Executive (including under Section 5) shall be paid to his estate.

13. Governing Law. This Agreement shall be governed, construed, interpreted, and enforced in accordance with the substantive laws of the State of Delaware, without reference to the principles of conflicts of law of Delaware or any other jurisdiction, and where applicable, the laws of the United States.

14. Validity. The invalidity or unenforceability of any provision or provisions of this Agreement shall not affect the validity or enforceability of any other provision of this Agreement, which shall remain in full force and effect.

15. Notices. Any notice, request, claim, demand, document, and other communication hereunder to any party hereto shall be effective upon receipt (or refusal of receipt) and shall be in writing and delivered personally or sent by telex, telecopy, email or sent by nationally recognized overnight courier, or certified or registered mail, postage prepaid, to the following address (or at any other address as any party hereto shall have specified by notice in writing to the other party hereto):

(a) If to the Company, to it at:

SCA Acquisition Holdings, LLC  
c/o Apollo Global Management, LLC  
9 West 57th Street  
43rd Floor  
New York, New York, United States  
10019  
Attention: Antoine Munfakh  
Email: [amunfakh@apolloJp.com](mailto:amunfakh@apolloJp.com)

with a copy (which shall not constitute notice) to:

Paul, Weiss, Rifkind, Wharton & Garrison LLP  
1285 Avenue of the Americas  
New York, New York 10019  
Fax: (212) 492-0237  
Attention: Brian Finnegan  
Andrew Gaines  
Email: [bfinnegan@paulweiss.com](mailto:bfinnegan@paulweiss.com)  
[againes@paulweiss.com](mailto:againes@paulweiss.com)

(b) If to the Executive, at his most recent address on the payroll records of the Company.

16. Counterparts. This Agreement may be executed in several counterparts, each of which shall be deemed to be an original, but all of which together will constitute one and the same Agreement, and shall become effective when one or more counterparts have been signed by each of the parties and delivered to the other parties.

17. Entire Agreement. The terms of this Agreement (together with any other agreements and instruments contemplated hereby or referred to herein) are intended by the parties hereto to be the final expression of their agreement with respect to the employment of the Executive by the Company and its Affiliates and to supersede any and all prior employment agreements, offer letters, severance agreements and similar agreements, plans, provisions, understandings or arrangements, whether written or oral (including, without limitation, the Prior Employment

Agreement and the Original Employment Agreement), and all such prior agreements, plans, provisions, understandings or arrangements shall be null and void in their entirety and of no further force or effect as of the Closing (as defined in the MIPA); provided, that the Executive shall remain eligible to receive the CIC Payment under the Prior Employment Agreement (as defined therein) in accordance with the terms thereof. For the avoidance of doubt, Executive shall have no right or entitlement to receive an annual bonus (whether prorated or otherwise) under Section 4.3 of the Prior Employment Agreement, and no such annual bonus shall be payable to the Executive. The parties hereto further intend that this Agreement shall constitute the complete and exclusive statement of its terms and that no extrinsic evidence whatsoever may be introduced in any judicial, administrative, or other legal proceeding to vary the terms of this Agreement.

18. Amendments; Waivers. This Agreement may not be modified, amended, or terminated except by an instrument in writing signed by the Executive and a duly authorized officer of the Company (other than the Executive) that expressly identifies the amended provision of this Agreement. By an instrument in writing similarly executed and similarly identifying the waived compliance, the Executive or a duly authorized officer of the Company may waive compliance by the other party or parties with any provision of this Agreement that such other party was or is obligated to comply with or perform; provided, however, that such waiver shall not operate as a waiver of, or estoppel with respect to, any other or subsequent failure to comply or perform. No failure to exercise and no delay in exercising any right, remedy, or power hereunder shall preclude any other or further exercise of any other right, remedy, or power provided herein or by law or in equity.

19. No Inconsistent Actions. The parties hereto shall not voluntarily undertake or fail to undertake any action or course of action inconsistent with the provisions or essential intent of this Agreement. Furthermore, it is the intent of the parties hereto to act in a fair and reasonable manner with respect to the interpretation and application of the provisions of this Agreement.

20. Construction. This Agreement shall be deemed drafted equally by both of the parties hereto. Its language shall be construed as a whole and according to its fair meaning. Any presumption or principle that the language is to be construed against any party shall not apply. The headings in this Agreement are only for convenience and are not intended to affect construction or interpretation. Any references to paragraphs, subparagraphs, sections, or subsections are to those parts of this Agreement, unless the context clearly indicates to the contrary. Also, unless the context clearly indicates to the contrary: (a) the plural includes the singular, and the singular includes the plural; (b) “and” and “or” are each used both conjunctively and disjunctively; (c) “any,” “all,” “each,” or “every” means “any and all,” and “each and every”; (d) “includes” and “including” are each “without limitation”; and (e) “herein,” “hereof,” “hereunder,” and other similar compounds of the word “here” refer to the entire Agreement and not to any particular paragraph, subparagraph, section, or subsection.

21. Dispute Resolution. The parties agree that any suit, action or proceeding brought by or against such party in connection with this Agreement shall be brought solely in any state or federal court within the State of Delaware. Each party expressly and irrevocably consents and submits to the jurisdiction and venue of each such court in connection with any such legal proceeding, including to enforce any settlement, order or award, and such party agrees to accept service of process by the other party or any of its agents in connection with any such proceeding. EACH PARTY HEREBY IRREVOCABLY WAIVES ALL RIGHT TO A TRIAL BY JURY IN ANY SUIT, ACTION OR OTHER PROCEEDING INSTITUTED BY OR AGAINST SUCH PARTY IN RESPECT OF ITS RIGHTS OR OBLIGATIONS HEREUNDER.

22. **Enforcement.** If any provision of this Agreement is held to be illegal, invalid, or unenforceable under present or future laws effective during the term of this Agreement, such provision shall be fully severable, this Agreement shall be construed and enforced as if such illegal, invalid, or unenforceable provision were never a part of this Agreement, and the remaining provisions of this Agreement shall remain in full force and effect and shall not be affected by the illegal, invalid, or unenforceable provision or by its severance from this Agreement. Furthermore, in lieu of such illegal, invalid, or unenforceable provision, there shall be added automatically as part of this Agreement a provision as similar in terms to such illegal, invalid, or unenforceable provision as may be possible and be legal, valid, and enforceable.

23. **Withholding.** The Company shall be entitled to withhold from any amounts payable under this Agreement any federal, state, local, and foreign withholding and other taxes and charges that the Company is required to withhold. The Company shall be entitled to rely on an opinion of counsel if any questions as to the amount or requirement of withholding shall arise.

24. **Employee Representations.** The Executive represents, warrants and covenants that (i) that he has read and understands this Agreement, is fully aware of its legal effect, has not acted in reliance upon any representations or promises made by the Company other than those contained in writing herein, and has entered into this Agreement freely based on his own judgment, (ii) Executive has the full right, authority and capacity to enter into this Agreement and perform Executive's obligations hereunder, (iii) Executive is not bound by any agreement that conflicts with or prevents or restricts the full performance of Executive's duties and obligations to the Company hereunder during or after the Term, (iv) the execution and delivery of this Agreement shall not result in any breach or violation of, or a default under, any existing obligation, commitment or agreement to which Executive is subject, and (v) the Executive shall keep all terms of this Agreement confidential, except with respect to disclosure to the Executive's spouse, accountants or attorneys, each of whom shall agree to keep all terms of this Agreement confidential. Prior to execution of this Agreement, the Executive was advised by the Company of the Executive's right to seek independent advice from an attorney of the Executive's own selection regarding this Agreement. The Executive acknowledges that the Executive has entered into this Agreement knowingly and voluntarily and with full knowledge and understanding of the provisions of this Agreement after being given the opportunity to consult with counsel. The Executive further represents that in entering into this Agreement, Executive is not relying on any statements or representations made by any of the Company's directors, officers, employees or agents that are not expressly set forth herein, and that the Executive is relying only upon Executive's own judgment and any advice provided by Executive's attorney.

*[signature page follows]*

The parties have executed this Agreement as of the date first written above.

**SCA ACQUISITION HOLDINGS, LLC**

By: /s/ David M. Davis

Name: David M. Davis

Title: Chief Financial Officer

**EXECUTIVE**

/s/ Jude Bricker

Jude Bricker

Exhibit A

Capital Account

<u>\$ in millions</u>		<u>% of total</u>
Apollo equity	255.0	97.0%
Jude Bricker equity	7.0	2.7%
Dave Siegel equity	1.0	0.4%
<b>Total equity</b>	<b><u>263.0</u></b>	<b><u>100.0%</u></b>

**EMPLOYMENT AGREEMENT**

This Employment Agreement (this "Agreement"), entered into on April 17, 2019, is made by and between David Davis (the "Executive") and MN Airlines, LLC, a Delaware limited liability company (together with any of its subsidiaries and Affiliates (as defined below) as may employ the Executive from time to time, and any and all successors thereto, the "Company").

**RECITALS**

A. The Company and Executive desire to enter into this Agreement to assure the Company of the exclusive services of the Executive and to set forth the rights and duties of the parties hereto.

B. This Agreement shall supersede any prior agreements or understandings, whether formal or informal, between Executive and the Company or any of its Affiliates.

**AGREEMENT**

NOW, THEREFORE, in consideration of the foregoing and of the respective covenants and agreements set forth below, the parties hereto agree as follows:

**1. Certain Definitions.**

- (a) "Action" shall have the meaning set forth in Section 9.
- (b) "Affiliate" shall mean, with respect to any Person, any other Person directly or indirectly controlling, controlled by, or under common control with such Person, where "control" shall have the meaning given such term under Rule 405 of the Securities Act of 1933, as amended.
- (c) "Agreement" shall have the meaning set forth in the preamble hereto.
- (d) "Annual Base Salary" shall have the meaning set forth in Section 3(a).
- (e) "Annual Bonus" shall have the meaning set forth in Section 3(b).
- (f) "Apollo" means, collectively, the investment funds managed, sponsored or advised by Apollo Management VIII, L.P. A reference to a member of Apollo is a reference to any such investment fund.
- (g) "Board" shall mean the Board of Directors of the Company.
- (h) The Company shall have "Cause" to terminate the Executive's employment pursuant to Section 4(a)(iii) hereunder upon (i) the Executive's indictment for, conviction of, or plea of guilty or nolo contendere to, any (x) felony, (y) misdemeanor involving moral turpitude, or (z) other crime involving either fraud or a breach of the Executive's duty of loyalty with respect to the Company or any Affiliates thereof, or any of its customers or suppliers, (ii) the Executive's failure to perform duties as reasonably directed by the Board (other than as a consequence of Disability) after written notice thereof and failure to cure within ten (10) business days of receipt



of the written notice, (iii) the Executive's fraud, misappropriation, embezzlement (whether or not in connection with employment), or material misuse of funds or property belonging to the Company or any of its Affiliates, (iv) the Executive's willful violation of the policies of the Company or any of its subsidiaries, or gross negligence in connection with the performance of his duties, after written notice thereof and failure to cure within ten (10) business days of receipt of written notice, (v) the Executive's use of alcohol that interferes with the performance of the Executive's duties or use of illegal drugs, if either (A) the Executive fails to obtain treatment within ten (10) business days after receipt of written notice thereof or (B) the Executive obtains treatment and, following Executive's return to work, the Executive's use of alcohol again interferes with the performance of the Executive's duties or the Executive again uses illegal drugs, (vi) the Executive's material breach of this Agreement, and failure to cure such breach within ten (10) business days after receipt of written notice, or (vii) the Executive's breach of the confidentiality or non-disparagement provisions (excluding unintentional breaches that are cured within ten (10) days after the Executive becomes aware of such breaches, to the extent curable) or the non-competition and non-solicitation provisions to which the Executive is subject (including, without limitation, under Sections 6 and 7 of this Agreement). If, within thirty (30) days subsequent to the Executive's termination of employment for any reason other than by the Company for Cause, the Company discovers facts such that the Executive's termination of employment could have been for Cause, the Executive's termination of employment will be deemed to have been for Cause for all purposes, and the Executive will be required to disgorge to the Company all amounts received under this Agreement, all equity awards or otherwise that would not have been payable to the Executive had such termination of employment been by the Company for Cause.

(i) "Code" shall mean the Internal Revenue Code of 1986, as amended.

(j) "Date of Termination" shall mean (i) if the Executive's employment is terminated by his death, the date of his death, (ii) if the Executive's employment is terminated pursuant to Section 4(a)(ii)-(v), the date specified or otherwise effective pursuant to Section 4(a)(v), or (iii) if the Executive's employment is terminated upon expiration of the Term due to either party's non-renewal in accordance with Section 2(b), the last day of the then-current Term.

(k) "Disability" shall mean the Executive's incapacitation through any illness, injury, accident or condition of either a physical or psychological nature that has resulted in his inability to perform the essential functions of his position, even with reasonable accommodations, for one hundred eighty (180) calendar days during any period of three hundred sixty-five (365) consecutive calendar days, and such incapacity is expected to continue, as determined by an independent medical examination and evaluated in accordance with the standard used under the Company's long-term disability insurance policy.

(l) "Executive" shall have the meaning set forth in the preamble hereto.

(m) "Initial Term" shall have the meaning set forth in Section 2(b).

(n) "Inventions" shall have the meaning set forth in Section 7(c)(i).

(o) “MIPA” shall mean the Membership Interest Purchase Agreement, by and among Minnesota Aviation, LLC, SCA Acquisition Holdings, LLC, and the other parties thereto, dated as of December 13, 2017.

(p) “Notice of Termination” shall have the meaning set forth in Section 4(a)(v).

(q) “Person” shall mean an individual, partnership, corporation, limited liability company, business trust, joint stock company, trust, unincorporated association, joint venture, governmental authority, or other entity of whatever nature.

(r) “Proprietary Rights” shall have the meaning set forth in Section 7(c)(i).

(s) “Term” shall have the meaning set forth in Section 2(b).

## 2. Employment

(a) In General. The Company shall employ the Executive, and the Executive shall be employed by the Company, for the period set forth in Section 2(b), in the position set forth in Section 2(c), and upon the other terms and conditions herein provided.

(b) Term of Employment. The term of employment under this Agreement (the “Term”) shall be for the period beginning on the Closing Date (as defined in the MIPA) and ending on the fifth (5<sup>th</sup>) anniversary of the Closing Date.

### (c) Position and Duties.

(i) During the Term, the Executive shall serve as Chief Financial Officer of the Company, with responsibilities, duties, and authority customary for such position. The Executive shall also serve as an officer of Affiliates of the Company as requested by the Board. During each year of the Term, Executive will be nominated to serve as a member of the Board, subject to shareholder approval of such nomination. The Executive shall not be entitled to any additional compensation for his service as a member of the Board or other positions or titles he may hold with any Affiliate of the Company to the extent he is so appointed. The Executive shall report to the Chief Executive Officer of the Company. The Executive agrees to observe and comply with the Company’s rules and policies as adopted from time to time by the Company. The Executive shall devote his full business time, skill, attention, and best efforts to the performance of his duties hereunder; provided, however, that the Executive shall be entitled to (A) serve on civic, charitable, and religious boards, (B) subject in each case to approval by the Board, serve on corporate boards, and (C) manage the Executive’s personal and family investments, in each case, to the extent that such activities do not interfere with the performance of the Executive’s duties and responsibilities hereunder, are not in conflict with the business interests of the Company or its Affiliates, and do not compete with the business of the Company or its Affiliates. During the Term, the Executive shall submit to the Board all business, commercial and investment opportunities or offers presented to the Executive or of which the Executive becomes aware which relate to the business of the Company and its Affiliates at any time during the Term, and unless approved by the Board, the Executive shall not accept or pursue, directly or indirectly, any such corporate opportunities on the Executive’s own behalf.

(ii) The Executive's employment shall be principally based at the Company's headquarters in the Minneapolis, Minnesota area. The Executive shall perform his duties and responsibilities to the Company at such principal place of employment and at such other location(s) to which the Company may reasonably require the Executive to travel for Company business purposes.

### 3. Compensation and Related Matters.

(a) Annual Base Salary. For the period of the Term ending March 31, 2019, Executive received a base salary at a rate of four hundred twenty thousand dollars (\$420,000) per annum, paid in accordance with the customary payroll practices of the Company (the "Annual Base Salary"). Beginning on April 1, 2019, Executive's Annual Base Salary shall be three hundred-sixty thousand dollars (\$360,000) per annum. The Board may review Executive's Annual Base Salary for increase from time to time in its sole discretion.

(b) Annual Bonus. For the calendar year ending December 31, 2018, Executive received a bonus of \$168,666. For calendar years 2019 and thereafter, Executive shall be eligible to receive a discretionary annual cash bonus with a target amount equal to seventy-five percent (75%) of the applicable Annual Base Salary (the "Annual Bonus"); provided, however, that for calendar year 2019, one-half of the target amount (\$135,000) shall be guaranteed and paid to Executive during the calendar year in equal installments in accordance with the Company's regular payroll practices (the "Guaranteed Bonus Amount"). During each successive year of the Term, Executive, may request, subject to the approval by the CEO and the Board of Directors, a portion of Annual Bonus to become guaranteed and payable as described above. The Executive's actual Annual Bonus for a given year, if any, shall be determined on the basis of the Executive's and/or the Company's attainment of objective financial and/or other subjective or objective criteria established by the Board and communicated to the Executive at the beginning of such year and reduced by any amount that is guaranteed as described above; provided, however, that the Annual Bonus shall never be less than \$0. Each such Annual Bonus shall be payable on such date as is determined by the Board, but in any event within the period required by Section 409A of the Code such that it qualifies as a "short-term deferral" pursuant to Section 1.409A-1(b)(4) of the Department of Treasury Regulations (or any successor thereto). Other than any Guaranteed Bonus Amount, no Annual Bonus shall be payable with respect to any calendar year unless the Executive remains continuously employed with the Company through the date of payment, except as otherwise provided herein or in Section 5.

(c) Equity.

(i) As soon as reasonably practicable following the Closing Date, the Executive shall be granted an option to purchase shares of common stock of SCA Acquisition Holdings, LLC equal to 1.20% of the fully diluted total outstanding shares of SCA Acquisition Holdings, LLC as of the date of grant (the "Option"), subject to the terms and conditions set forth in the Company's equity incentive plan (the "Equity Plan") and a nonqualified stock option agreement thereunder.

(ii) The Executive shall have the opportunity to purchase shares of common stock of SCA Acquisition Holdings, LLC at the same indicative price per share that is paid by Apollo (the "Purchased Interests"), subject to the Executive becoming a party to the Company's investor rights agreement, provided that the Executive must notify the Company of such election in advance of the Closing Date.

(d) Executive Travel Benefits. The Executive is entitled to both positive-space and space-available travel benefits, in accordance with the Company's rules and policies.

(i) Positive Space Travel. Positive space travel is permitted as follows: the Executive will receive an annual credit of \$12,500 in the Executive's Universal Air Travel Plan ("UATP") account for personal travel on Company scheduled flights for the Executive and certain Qualifying Friends and Family (as defined below). Each flown segment is valued at \$75, and deducted from the UATP account. The value of this benefit is reported as taxable income with taxes on such income paid for by the Company.

(ii) Qualifying Friends & Family. "Qualifying Friends and Family" are defined as follows:

(A) If the Executive travels on a flight itinerary, the Executive may bring up to eight friends or family members, on the same itinerary, on any scheduled Company flight (provided such persons are not prohibited by Company from traveling on Company flights).

(B) If the Eligible Executive is not listed on the flight itinerary, i) the Executive's Circle Of Travelers (defined under the Company's Employee Travel Policy) may use the Executive's positive travel benefit for any scheduled Company flight and flown segments will be deducted from the UATP account; or ii) any friend or family member not otherwise prohibited by Company from traveling on Company's flights, may travel to and/or from the Executive's then-present location or homestead, to visit the Executive and/or Executive's family.

(iii) Space Available Travel. The Executive and the Executive's Circle Of Travelers may also travel on scheduled Company flights in accordance with the Company's Employee Travel Policy, in which case, flown segments will not be deducted from the Executive's UATP account.

(e) Vesting. Upon the earlier of (x) five (5) years from April 11, 2018, or (y) a Change in Control (as defined in the Equity Plan), Executive's travel benefits under this Section 3(d) shall vest for the Executive's lifetime and therefore be useable by Executive for the remainder of Executive's life. The terms related to the Company's policies shall be defined as the terms were defined the day before the execution of any agreement or event that would trigger the vesting described here.

(f) Benefits. During the Term, the Executive shall be entitled to participate in the employee benefit plans, programs, and arrangements of the Company as may be in effect from time to time, in accordance with their terms.

(g) Vacation. During the Term, the Executive shall be entitled to vacation in accordance with the Company's vacation policies, as then in effect. Any vacation shall be taken at a time that does not unreasonably interfere with the Executive's work and the Company's operations.

(h) Business Expenses. During the Term, the Company shall reimburse the Executive for all reasonable travel and other business expenses incurred by him in the performance of his duties to the Company, in accordance with the Company's expense reimbursement policies and procedures.

(i) Long Term Incentive Bonus. In the event the Executive elects the Option Term, Executive shall be entitled to participate in the Company's then-prevailing long-term incentive plan ("Long-Term Incentive"). The Executive's actual Long-Term Incentive for a given year, if any, shall be determined on the basis of the Executive's and/or the Company's attainment of objective financial and/or other subjective or objective criteria established by the Board and communicated to the Executive at the beginning of such year. Each such Long-Term Incentive shall be payable on such date as is determined by the Board, but in any event within the period required by Section 409A of the Code such that it qualifies as a "short-term deferral" pursuant to Section 1.409A-1(b)(4) of the Department of Treasury Regulations (or any successor thereto). Notwithstanding the foregoing, no Long-Term Incentive shall be payable with respect to any calendar year unless the Executive remains continuously employed with the Company through the date of payment, except as otherwise provided in Section 5.

4. Termination. Prior to the expiration of the Term resulting from a non-renewal pursuant to Section 2(b) above, the Executive's employment hereunder may be terminated without any breach of this Agreement only under the following circumstances:

(a) Circumstances.

(i) Death. The Executive's employment hereunder shall terminate upon his death.

(ii) Disability. If the Executive has incurred a Disability, the Company may give the Executive written notice of its intention to terminate the Executive's employment. In that event, the Executive's employment with the Company shall terminate effective on the later of the thirtieth (30th) day after receipt of such notice by the Executive and the date specified in such notice, provided that within the thirty (30) day period following receipt of such notice, the Executive shall not have returned to full-time performance of his duties hereunder.

(iii) Termination with Cause. The Company may terminate the Executive's employment with Cause.

(iv) Termination without Cause. The Company may terminate the Executive's employment without Cause.

(v) Resignation. The Executive may resign from his employment upon not less than sixty (60) days' advance written notice to the Board.

(b) Notice of Termination. Any termination of the Executive's employment by the Company or by the Executive under this Section 4 (other than termination pursuant to Section 4(a)(i)) shall be communicated by a written notice to the other party hereto (i) indicating the specific termination provision in this Agreement relied upon, (ii) except with respect to a termination pursuant to Section 4(a)(iv), setting forth in reasonable detail the facts and circumstances claimed to provide a basis for termination of the Executive's employment under the provision so indicated, and (iii) specifying a Date of Termination as provided herein (a "Notice of Termination"). If the Company delivers a Notice of Termination under Section 4(a)(ii), the Date of Termination shall be at least sixty (60) days following the date of such notice; provided, however, that such notice need not specify a Date of Termination, in which case the Date of Termination shall be determined pursuant to Section 4(a)(ii). If the Company delivers a Notice of Termination under Section 4(a)(iii) or 4(a)(iv), the Date of Termination shall be, in the Company's sole discretion, the date on which the Executive receives such notice or any subsequent date selected by the Company. If the Executive delivers a Notice of Termination under Section (a)(v), the Date of Termination shall be at least sixty (60) days following the date of such notice: provided, however, in each case, that the Company may, in its sole discretion, accelerate the Date of Termination to any date that occurs following the Company's receipt of such notice, without changing the characterization of such termination as voluntary, even if such date is prior to the date specified in such notice and without having to pay any compensation or benefits for the balance of such notice period. The failure by the Company to set forth in the Notice of Termination any fact or circumstance that contributes to a showing of Cause shall not waive any right of the Company hereunder or preclude the Company from asserting such fact or circumstance in enforcing the Company's rights hereunder.

(c) Termination of All Positions. Upon termination of the Executive's employment for any reason, the Executive agrees to resign, as of the Date of Termination or such other date requested by the Company, from all positions and offices that the Executive then holds with the Company and its Affiliates. The Executive agrees to promptly execute such documents as the Company, in its sole discretion, shall reasonably deem necessary to effect such resignations, and in the event that the Executive is unable or unwilling to execute any such document, Executive hereby grants his proxy to any officer of the Company to so execute on his behalf.

(d) Suspension of Duties. The Company reserves the right to bar the Executive from the offices of the Company or any of its Affiliates and to require that the Executive refrain from undertaking all or any of the Executive's duties and contacting clients, colleagues and advisors of the Company or any of its Affiliates (unless otherwise instructed) during all or part of any period of notice of Executive's termination of employment. Should the Company exercise this right, all the Executive's other duties and obligations hereunder, including the Executive's duties of fidelity and confidentiality to the Company, remain in full force and effect and, during any such period, the Executive shall remain a service provider to the Company and shall not be employed or engaged in any other business. For the avoidance of doubt, the Company shall continue to pay to the Executive the Annual Base Salary and to provide health and welfare benefits during any such notice period, until the Date of Termination.

## **5. Company Obligations upon Termination of Employment.**

(a) **In General** Subject to Section 10(a), upon termination of the Executive's employment for any reason, the Executive (or the Executive's estate) shall be entitled to receive (i) any amount of the Executive's Annual Base Salary earned through the Date of Termination not theretofore paid, (ii) any Annual Bonus (and if applicable, any Long-Term Incentive) for the year prior to the year in which the Date of Termination occurred, that was earned but not yet paid, (iii) any expenses owed to the Executive under Section 3(f), and (iv) any amount arising from the Executive's participation in, or benefits under, any employee benefit plans, programs, or arrangements under Section 3(d) (other than severance plans, programs, or arrangements), which amounts shall be payable in accordance with the terms and conditions of such employee benefit plans, programs, or arrangements including, where applicable, any death and disability benefits (the "**Accrued Obligation**"). Notwithstanding anything to the contrary, upon a termination by the Company with Cause, the Accrued Obligations shall not include the amount set forth in clause (ii) of the preceding sentence.

(b) **Termination without Cause or Non-Renewal by the Company**. Subject to Section 10(a) and subject to the Executive's continued compliance with the covenants contained in Sections 6 and 7, if the Company terminates the Executive's employment without Cause pursuant to Section 4(a)(iv) or the Company elects not to renew the Term pursuant to Section 2(b), the Company shall, in addition to the Accrued Obligations, continue to pay the Annual Base Salary in accordance with the Company's customary payroll practices during the period beginning on the Date of Termination and ending on the earlier to occur of (A) the twelve (12) month anniversary of the Date of Termination and (B) the first date that the Executive violates any covenant contained in Section 6 or 7, after receipt of written notice thereof and expiration of a 10 business day cure period: **provided, however**, the installment payments payable pursuant to this Section 5(b) shall commence on the first payroll period following the effective date of the Release (as defined below), and the initial installment shall include a lump-sum payment of all amounts accrued under this Section 5(b) from the Date of Termination through the date of such initial payment.

(c) **Release**. Notwithstanding anything herein to the contrary, the amounts payable to the Executive under Sections 5(b), other than the Accrued Obligations, shall be contingent upon and subject to the Executive's (or the Executive's estate, if applicable) execution and non-revocation of a general waiver and release of claims agreement in the Company's customary form (the "**Release**") (and the expiration of any applicable revocation period), on or prior to the sixtieth (60<sup>th</sup>) day following the Date of Termination.

(d) **Survival**. The expiration or termination of the Term shall not impair the rights or obligations of any party hereto, which shall have accrued prior to such expiration or termination.

## **6. Non-Competition; Non-Solicitation; Non-Hire.**

(a) To the fullest extent permitted by applicable law, the Executive agrees that during the Executive's employment with the Company, and for the twelve (12) month period following the Executive's termination of employment for any reason, the Executive will not, directly or indirectly, engage in, have any equity or equity-based interest in, or manage or operate any Person, firm, corporation, partnership, business or entity (whether as director, officer, employee, agent, representative, partner, security holder, consultant, or otherwise) that engages in (either directly or through any subsidiary or Affiliate thereof) any business or activity that competes with any of the businesses of the Company or any entity owned by the Company (including, without limitation, any United States regional air carrier or any non-mainline carrier in Mexico, Canada or the Caribbean). Notwithstanding the foregoing, the Executive shall be permitted to acquire a passive stock or equity interest in such a business, provided that the stock or other equity interest acquired is not more than one percent (1%) of the outstanding interest in such business;

(b) To the fullest extent permitted by applicable law, the Executive agrees that during the Executive's employment with the Company, and for the twelve (12) month period following the Executive's termination of employment for any reason, the Executive will not, directly or indirectly, on the Executive's own behalf or on behalf of another (i) solicit, induce or attempt to solicit or induce any officer, director or employee of the Company to terminate their relationship with or leave the employ of the Company, or in any way interfere with the relationship between the Company, on the one hand, and any officer, director or employee thereof, on the other hand, (ii) hire (or other similar arrangement) any Person (in any capacity whether as an officer, director, employee or consultant) who is or at any time was an officer, director or employee of the Company until twelve (12) months after such individual's relationship (whether as an officer, director or employee) with the Company has ended, or (iii) induce or attempt to induce any customer, supplier, prospect, licensee or other business relation of the Company to cease doing business with the Company, or in any way interfere with the relationship between any such customer, supplier, prospect, licensee or business relation, on the one hand, and the Company, on the other hand; provided, that it shall not be a violation of this Section 6(b) for a subsequent employer of the Executive to hire a Company employee who is at the "director" level or below, so long as such Company employee responds to generic, non-targeted position advertising and the Executive does not engage in activities prohibited by clause (i) of this Section 6(b) with respect to such Company employee.

(c) In the event that the terms of this Section 6 shall be determined by any court of competent jurisdiction to be unenforceable by reason of its extending for too great a period of time or over too great a geographical area or by reason of its being too extensive in any other respect, it will be interpreted to extend only over the maximum period of time for which it may be enforceable, over the maximum geographical area as to which it may be enforceable, or to the maximum extent in all other respects as to which it may be enforceable, all as determined by such court in such action. The Executive hereby acknowledges that the terms of this Section 6 are reasonable in terms of duration, scope and area restrictions and are necessary to protect the goodwill of the Company. The Executive hereby authorizes the Company to inform any future employer or prospective employer of the existence and terms of Sections 6 and 7 of this Agreement without liability for interference with the Executive's employment or prospective employment.

(d) The Executive acknowledges that the Company has expended and shall continue to expend substantial amounts of time, money and effort to develop business strategies, employee and customer relationships and goodwill and build an effective organization. The Executive recognizes and acknowledges that he has access to confidential information and trade secrets, and has had or will have material contact with the Company's customers, suppliers, licensees, representatives, agents, partners, licensors, or business relations, and that the Executive's services are of special, unique and extraordinary value to the Company and its Affiliates. The Executive acknowledges that the Company has a legitimate business interest and right in protecting its confidential information, business strategies, employee and customer relationships and goodwill, and that the Company would be seriously damaged by the disclosure of confidential information and the loss or deterioration of its business strategies, employee and customer relationships and goodwill. The Executive acknowledges (i) that the business of the Company and its Affiliates is



international in scope and without geographical limitation and (ii) notwithstanding the jurisdiction of formation or principal office of the Company and its Affiliates, or the location of any of their respective executives or employees (including, without limitation, the Executive), it is expected that the Company and its Affiliates will have business activities and have valuable business relationships within their respective industries throughout the world. The Executive further acknowledges that although his compliance with the covenants contained in Sections 6 and 7 may prevent the Executive from earning a livelihood in a business similar to the business of the Company, the Executive's experience and capabilities are such that the Executive has other opportunities to earn a livelihood and adequate means of support for the Executive and the Executive's dependents. In addition, the Executive agrees and acknowledges that the potential harm to the Company of the non-enforcement of Sections 6 and 7 outweighs any potential harm to the Executive of their enforcement by injunction or otherwise.

(e) As used in this Section 6, the term "Company" shall include the Company, and any direct or indirect subsidiaries thereof or any successors thereto.

#### 7. Nondisclosure of Confidential Information; Nondisparagement; Intellectual Property.

(a) Non-Disclosure of Confidential Information; Return of Property. Except as required in the faithful performance of the Executive's duties hereunder, Executive agrees that during the Term and in perpetuity thereafter, the Executive shall maintain in confidence and shall not directly, indirectly or otherwise, use, disseminate, disclose or publish, or use for the Executive's benefit or the benefit of any Person, any confidential or proprietary information or trade secrets of or relating to the Company, including, without limitation, information with respect to the Company's operations, processes, products, inventions, business practices, finances, principals, vendors, suppliers, customers, potential customers, marketing methods, costs, prices, contractual relationships, regulatory status, compensation paid to employees or other terms of employment, or deliver to any Person any document, record, notebook, computer program or similar repository of or containing any such confidential or proprietary information or trade secrets. Confidential Information shall not include any information that is generally known to the industry or the public other than as a result of the Executive's breach of this covenant or any breach of other confidentiality obligations by third parties. Upon the Executive's termination of employment for any reason, the Executive shall promptly deliver to the Company all correspondence, drawings, manuals, letters, notes, notebooks, reports, programs, plans, proposals, financial documents, or any other documents concerning the Company's customers, business plans, marketing strategies, products or processes. The Executive may respond to a lawful and valid subpoena or other legal process but shall give the Company the earliest possible notice thereof, shall, as much in advance of the return date as possible, make available to the Company and its counsel the documents and other information sought and, if requested by the Company, shall reasonably assist such counsel in resisting or otherwise responding to such process.

(b) Non-Disparagement. The Executive shall not, at any time during the Term and in perpetuity thereafter, directly or indirectly, knowingly disparage, criticize, or otherwise make derogatory statements regarding the Company and its officers, the members of the Board, and the respective Affiliates of any of the foregoing. The foregoing shall not be violated by the Executive's truthful responses to legal process or inquiry by a governmental authority.

(c) Intellectual Property Rights.

(i) The Executive agrees that the results and proceeds of the Executive's services for the Company (including, but not limited to, any trade secrets, products, services, processes, know-how, designs, developments, innovations, analyses, drawings, reports, techniques, formulas, methods, developmental or experimental work, improvements, discoveries, inventions, ideas, source and object codes, programs, matters of a literary, musical, dramatic or otherwise creative nature, writings and other works of authorship) resulting from services performed for the Company and any works in progress, whether or not patentable or registrable under copyright or similar statutes, that were made, developed, conceived or reduced to practice or learned by the Executive, either alone or jointly with others (collectively, "Inventions"), shall be works-made-for-hire and the Company (or, if applicable or as directed by the Company) shall be deemed the sole owner throughout the universe of any and all trade secret, patent, copyright and other intellectual property rights (collectively, "Proprietary Rights") of whatsoever nature therein, whether or not now or hereafter known, existing, contemplated, recognized or developed, with the right to use the same in perpetuity in any manner the Company determines in its sole discretion, without any further payment to the Executive whatsoever. If, for any reason, any of such results and proceeds shall not legally be a work-made-for-hire and/or there are any Proprietary Rights which do not accrue to the Company under the immediately preceding sentence, then the Executive hereby irrevocably assigns and agrees to assign any and all of the Executive's right, title and interest thereto, including, without limitation, any and all Proprietary Rights of whatsoever nature therein, whether or not now or hereafter known, existing, contemplated, recognized or developed, to the Company (or, if applicable or as directed by the Company, any of its Affiliates), and the Company or such Affiliates shall have the right to use the same in perpetuity throughout the universe in any manner determined by the Company or such Affiliates without any further payment to the Executive whatsoever. As to any Invention that the Executive is required to assign, the Executive shall promptly and fully disclose to the Company all information known to the Executive concerning such Invention. The Executive hereby waives and quitclaims to the Company any and all claims, of any nature whatsoever, that the Executive now or may hereafter have for infringement of any Proprietary Rights assigned hereunder to the Company. In accordance with applicable law, this section 7(c) does not apply to any Inventions for which no equipment, supplies, facilities, trade secrets or other Confidential Information of the Company was used and which was developed entirely on the Executive's own time unless (a) the Invention relates to the Company's business or the Company's actual or demonstrably anticipated research or development; or (b) the Invention results from any work performed by the Executive for the Company.

(ii) The Executive agrees that, from time to time, as may be requested by the Company and at the Company's sole cost and expense, the Executive shall do any and all things that the Company may reasonably deem useful or desirable to establish or document the Company's exclusive ownership throughout the United States of America or any other country of any and all Proprietary Rights in any such Inventions, including, without limitation, the execution of appropriate copyright and/or patent applications or assignments. To the extent the Executive has any Proprietary Rights in the Inventions that cannot be assigned in the manner described above, the Executive unconditionally and irrevocably waives the enforcement of such Proprietary Rights. This Section 7(c)(ii) is subject to and shall not be deemed to limit, restrict or constitute any waiver by the Company of any Proprietary Rights of ownership to which the Company may be entitled

by operation of law by virtue of the Executive's employment with, or service to, the Company. The Executive further agrees that, from time to time, as may be requested by the Company and at the Company's sole cost and expense, the Executive shall assist the Company in every proper and lawful way to obtain and from time to time enforce Proprietary Rights relating to Inventions in any and all countries. To this end, the Executive shall execute, verify and deliver such documents and perform such other acts (including appearances as a witness) as the Company may reasonably request for use in applying for, obtaining, perfecting, evidencing, sustaining, and enforcing such Proprietary Rights and the assignment thereof. In addition, the Executive shall execute, verify, and deliver assignments of such Proprietary Rights to the Company or its designees. The Executive's obligation to assist the Company with respect to Proprietary Rights relating to such Inventions in any and all countries shall continue beyond the termination of the Executive's employment with the Company.

(d) Prior Employment Information. The Executive further agrees that the Executive will not improperly use or disclose any confidential information or trade secrets, if any, of any former employers or any other Person to whom the Executive has an obligation of confidentiality, and will not bring onto the premises of the Company or its Affiliates any unpublished documents or any property belonging to any former employer or any other Person to whom the Executive has an obligation of confidentiality unless consented to in writing by the former employer or other Person.

(e) Notwithstanding anything to the contrary contained in this Agreement, (i) the Executive will not be held criminally or civilly liable under any federal or state trade secret law for any disclosure of a trade secret that is made: (A) in confidence to a federal, state, or local government official, either directly or indirectly, or to an attorney; and (B) solely for the purpose of reporting or investigating a suspected violation of law; or is made in a complaint or other document that is filed under seal in a lawsuit or other proceeding, and (ii) nothing in this Agreement shall prohibit Executive from reporting possible violations of federal law or regulation to or otherwise cooperating with or providing information requested by any governmental agency or entity, including, but not limited to, the Department of Justice, the Securities and Exchange Commission, the Congress, and any agency Inspector General, or making other disclosures that are protected under the whistleblower provisions of federal law or regulation. The Executive does not need the prior authorization of the Company to make any such reports or disclosures and the Executive is not required to notify the Company that the Executive has made such reports or disclosures. If the Executive files a lawsuit for retaliation by the Company for reporting a suspected violation of law, the Executive may disclose the Company's trade secrets to the Executive's attorney and use the trade secret information in the court proceeding if the Executive: (x) files any document containing the trade secret under seal; and (y) does not disclose the trade secret, except pursuant to court order.

(f) As used in this Section 7, the term "Company" shall include the Company, and any direct or indirect subsidiaries thereof or any successors thereto.

**8. Injunctive Relief.** The Executive recognizes and acknowledges that a breach of any of the covenants contained in Sections 6 and 7 may cause irreparable damage to the Company and its goodwill, the exact amount of which may be difficult or impossible to ascertain, and that the remedies at law for any such breach may be inadequate. Accordingly, the Executive agrees that

in the event of a breach or threatened breach of any of the covenants contained in Sections 6 and 7, in addition to any other remedy that may be available at law or in equity, the Company will be entitled (without the necessity of showing economic loss or other actual damage) to specific performance and injunctive relief (without posting a bond). In the event of any breach or violation by the Executive of any of the covenants contained in Section 6 and 7, the time period of such covenant with respect to the Executive shall, to the fullest extent permitted by law, be tolled until such breach or violation is resolved.

**9. Cooperation.** The Executive agrees that during and after his employment with the Company, the Executive will assist the Company and its Affiliates in the defense of any claims or potential claims that may be made or threatened to be made against the Company or any of its Affiliates in any action, suit, or proceeding, whether civil, criminal, administrative, investigative, or otherwise (each, an "Action"), and will assist the Company and its Affiliates in the prosecution of any claims that may be made by the Company or any of its Affiliates in any Action, to the extent that such claims may relate to the Executive's employment or the period of the Executive's employment by the Company and its Affiliates. The Executive agrees, unless precluded by law, to promptly inform the Company if the Executive is asked to participate (or otherwise become involved) in any such Action. The Executive also agrees, unless precluded by law, to promptly inform the Company if the Executive is asked to assist in any investigation (whether governmental or otherwise) of the Company or any of its Affiliates (or their actions) to the extent that such investigation may relate to the Executive's employment or the period of the Executive's employment by the Company, regardless of whether a lawsuit has then been filed against the Company or any of its Affiliates with respect to such investigation. The Company or one of its Affiliates shall reimburse the Executive for all of the Executive's reasonable out-of-pocket expenses associated with such cooperation following his Date of Termination.

**10. Section 409A of the Code.**

(a) General. The parties hereto acknowledge and agree that, to the extent applicable, this Agreement shall be interpreted in accordance with, and incorporate the terms and conditions required by, Section 409A of the Code and the Department of Treasury Regulations and other interpretive guidance issued thereunder, including without limitation any such regulations or other guidance that may be issued after the date hereof. Notwithstanding any provision of this Agreement to the contrary, in the event that the Company determines that any amounts payable hereunder will be taxable currently to the Executive under Section 409A(a)(1)(A) of the Code and related Department of Treasury guidance, the Company and the Executive shall cooperate in good faith to (i) adopt such amendments to this Agreement and appropriate policies and procedures, including amendments and policies with retroactive effect, that they mutually determine to be necessary or appropriate to preserve the intended tax treatment of the benefits provided by this Agreement, to preserve the economic benefits of this Agreement, and to avoid less-favorable accounting or tax consequences for the Company, and/or (ii) take such other actions as mutually determined to be necessary or appropriate to exempt the amounts payable hereunder from Section 409A of the Code or to comply with the requirements of Section 409A of the Code and thereby avoid the application of penalty taxes thereunder; provided, however, that this Section 10(a) does not create an obligation on the part of the Company to modify this Agreement and does not guarantee that the amounts payable hereunder will not be subject to interest or penalties under Section 409A, and in no event whatsoever shall the Company or any of its Affiliates be liable for any additional tax, interest, or penalties that may be imposed on the Executive as a result of Section 409A of the Code or any damages for failing to comply with Section 409A of the Code.

(b) Separation from Service Under Section 409A. Notwithstanding any provision to the contrary in this Agreement: (i) no amount that is “nonqualified deferred compensation” subject to Section 409A of the Code shall be payable pursuant to Section 5 unless the termination of the Executive’s employment constitutes a “separation from service” within the meaning of Section 1.409A-1(h) of the Department of Treasury Regulations; (ii) if the Executive is deemed at the time of his separation from service to be a “specified employee” for purposes of Section 409A(a)(2)(B)(i) of the Code, to the extent that delayed commencement of any portion of the termination benefits to which the Executive is entitled under this Agreement (after taking into account all exclusions applicable to such termination benefits under Section 409A), including, without limitation, any portion of the additional compensation awarded pursuant to Section 5, is required in order to avoid a prohibited distribution under Section 409A(a)(2)(B)(i) of the Code, such portion of the Executive’s termination benefits shall not be provided to the Executive prior to the earlier of (A) the expiration of the six-month period measured from the date of the Executive’s “separation from service” with the Company (as such term is defined in the Department of Treasury Regulations issued under Section 409A) and (B) the date of the Executive’s death: provided, that upon the earlier of such dates, all payments deferred pursuant to this Section 11(b)(ii) shall be paid to the Executive in a lump sum, and any remaining payments due under this Agreement shall be paid as otherwise provided herein; (iii) the determination of whether the Executive is a “specified employee” for purposes of Section 409A(a)(2)(B)(i) of the Code as of the time of his separation from service shall be made by the Company in accordance with the terms of Section 409A of the Code and applicable guidance thereunder (including, without limitation, Section 1.409A-1(i) of the Department of Treasury Regulations and any successor provision thereto); (iv) for purposes of Section 409A of the Code, the Executive’s right to receive installment payments pursuant to Section 5 shall be treated as a right to receive a series of separate and distinct payments; (v) if the sixty day period following the Date of Termination ends in the calendar year following the year that includes the Date of Termination, then payment of any amount that is conditioned upon the execution of the Release and is subject to Section 409A shall not be paid until the first day of the calendar year following the year that includes the Date of Termination, regardless of when the Release is signed; and (vi) to the extent that any reimbursement of expenses or in-kind benefits constitutes “deferred compensation” under Section 409A, such reimbursement or benefit shall be provided no later than December 31 of the year following the year in which the expense was incurred. The amount of expenses reimbursed in one year shall not affect the amount eligible for reimbursement in any subsequent year. The amount of any in-kind benefits provided in one year shall not affect the amount of in-kind benefits provided in any other year. The right to any benefits or reimbursements or in-kind benefits may not be liquidated or exchanged for any other benefit.

#### **11. Section 280G of the Code.**

(a) If there is a change of ownership or effective control or change in the ownership of a substantial portion of the assets of a corporation (within the meaning of Section 280G of the Code) and any payment or benefit (including payments and benefits pursuant to this Agreement) that the Executive would receive from the Company or otherwise ( “Transaction Payment”), would (i) constitute a “parachute payment” within the meaning of Section 280G of the Internal Revenue

Code of 1986 (the “Code”), and (ii) but for this sentence, be subject to the excise tax imposed by Section 4999 of the Code (the “Excise Tax”), then the Company shall cause to be determined, before any amounts of the Transaction Payment are paid to the Executive, which of the following two alternative forms of payment would result in the Executive’s receipt, on an after-tax basis, of the greater amount of the Transaction Payment notwithstanding that all or some portion of the Transaction Payment may be subject to the Excise Tax: (x) payment in full of the entire amount of the Transaction Payment (a “Full Payment”), or (y) payment of only a part of the Transaction Payment so that the Executive receives the largest payment possible without the imposition of the Excise Tax (a “Reduced Payment”). For purposes of determining whether to make a Full Payment or a Reduced Payment, the Company shall cause to be taken into account all applicable federal, state and local income and employment taxes and the Excise Tax (all computed at the highest applicable marginal rate, net of the maximum reduction in federal income taxes which could be obtained from a deduction of such state and local taxes). If a Reduced Payment is made, the reduction in payments and/or benefits will occur in the following order: (1) cash payments (from latest scheduled to earliest scheduled); (2) any equity or equity derivatives that are included under Section 2800 of the Code at full value rather than accelerated value (with the highest value reduced first); and (3) any equity or equity derivatives included under Section 2800 of the Code at an accelerated value (and not at full value), with the highest value reduced first (as such values are determined under Treasury Regulation Section 1.2800-1, Q&A 24); and (4) any other non-cash benefits (from latest scheduled to earliest scheduled).

(b) Unless the Executive and the Company otherwise agree in writing, any determination required under this section shall be made in writing by the Company’s independent public accountants (the “Accountants”), whose determination shall be conclusive and binding upon the Executive and the Company for all purposes. For purposes of making the calculations required by this section, the Accountants may make reasonable assumptions and approximations concerning applicable taxes and may rely on reasonable, good faith interpretations concerning the application of Sections 2800 and 4999 of the Code. The Accountants shall provide detailed supporting calculations to the Company and the Executive as requested by the Company or the Executive. The Executive and the Company shall furnish to the Accountants such information and documents as the Accountants may reasonably request in order to make a determination under this section. The Company shall bear all costs the Accountants may reasonably incur in connection with any calculations contemplated by this Section 11(b).

(c) Notwithstanding the foregoing, in the event that no stock of the Company or its Affiliates is readily tradable on an established securities market or otherwise (within the meaning of Section 2800 of the Code) at the time of the change in control, the Board may elect to submit to a vote of shareholders for approval the portion of the Transaction Payments that equals and exceeds three times the Executive’s “base amount” (within the meaning of Section 2800 of the Code) (the “Excess Parachute Payments”), in accordance with Treas. Reg. §1.2800-1, and the Executive shall cooperate with such vote of shareholders, including the execution of any required documentation subjecting the Executive’s entitlement to all Excess Parachute Payments to such shareholder vote.

**12. Assignment and Successors.** The Company may assign its rights and obligations under this Agreement to any entity, including any successor to all or substantially all the assets of the Company, by merger or otherwise, and may assign or encumber this Agreement and its rights hereunder as security for indebtedness of the Company and its Affiliates. The Executive may not assign his rights or obligations under this Agreement to any individual or entity. This Agreement shall be binding upon and inure to the benefit of the Company and the Executive and their respective successors, assigns, personnel, legal representatives, executors, administrators, heirs, distributees, devisees, and legatees, as applicable. In the event of the Executive's death following a termination of his employment, all unpaid amounts otherwise due the Executive (including under Section 5) shall be paid to his estate.

**13. Governing Law.** This Agreement shall be governed, construed, interpreted, and enforced in accordance with the substantive laws of the State of Delaware, without reference to the principles of conflicts of law of Delaware or any other jurisdiction, and where applicable, the laws of the United States.

**14. Validity.** The invalidity or unenforceability of any provision or provisions of this Agreement shall not affect the validity or enforceability of any other provision of this Agreement, which shall remain in full force and effect.

**15. Notices.** Any notice, request, claim, demand, document, and other communication hereunder to any party hereto shall be effective upon receipt (or refusal of receipt) and shall be in writing and delivered personally or sent by telex, telecopy, email or sent by nationally recognized overnight courier, or certified or registered mail, postage prepaid, to the following address (or at any other address as any party hereto shall have specified by notice in writing to the other party hereto):

(a) If to the Company, to it at:

MN Airlines, LLC  
c/o Apollo Global Management, LLC  
9 West 57th Street  
43rd Floor  
New York, New York, United States  
10019

Attention: Antoine Munfakh  
Email: [amunfakh@apolloip.com](mailto:amunfakh@apolloip.com)

with a copy (which shall not constitute notice) to:

Paul, Weiss, Rifkind, Wharton & Garrison LLP  
1285 Avenue of the Americas  
New York, New York 10019  
Fax: (212) 492-0237

Attention: Brian Finnegan  
Andrew Gaines  
Email: [bfinnegan@paulweiss.com](mailto:bfinnegan@paulweiss.com)  
[againes@paulweiss.com](mailto:againes@paulweiss.com)

(b) If to the Executive, at his most recent address on the payroll records of the Company.

**16. Counterparts.** This Agreement may be executed in several counterparts, each of which shall be deemed to be an original, but all of which together will constitute one and the same Agreement, and shall become effective when one or more counterparts have been signed by each of the parties and delivered to the other parties.

**17. Entire Agreement.** The terms of this Agreement (together with any other agreements and instruments contemplated hereby or referred to herein) are intended by the parties hereto to be the final expression of their agreement with respect to the employment of the Executive by the Company and its Affiliates and to supersede any and all prior employment agreements, offer letters, severance agreements and similar agreements, plans, provisions, understandings or arrangements, whether written or oral, and all such prior agreements, plans, provisions, understandings or arrangements shall be null and void in their entirety and of no further force or effect as of the Closing (as defined in the MIPA). The parties hereto further intend that this Agreement shall constitute the complete and exclusive statement of its terms and that no extrinsic evidence whatsoever may be introduced in any judicial, administrative, or other legal proceeding to vary the terms of this Agreement.

**18. Amendment; Waivers.** This Agreement may not be modified, amended, or terminated except by an instrument in writing signed by the Executive and a duly authorized officer of the Company (other than the Executive) that expressly identifies the amended provision of this Agreement. By an instrument in writing similarly executed and similarly identifying the waived compliance, the Executive or a duly authorized officer of the Company may waive compliance by the other party or parties with any provision of this Agreement that such other party was or is obligated to comply with or perform; provided, however, that such waiver shall not operate as a waiver of, or estoppel with respect to, any other or subsequent failure to comply or perform. No failure to exercise and no delay in exercising any right, remedy, or power hereunder shall preclude any other or further exercise of any other right, remedy, or power provided herein or by law or in equity.

**19. No Inconsistent Actions.** The parties hereto shall not voluntarily undertake or fail to undertake any action or course of action inconsistent with the provisions or essential intent of this Agreement. Furthermore, it is the intent of the parties hereto to act in a fair and reasonable manner with respect to the interpretation and application of the provisions of this Agreement.

**20. Construction.** This Agreement shall be deemed drafted equally by both of the parties hereto. Its language shall be construed as a whole and according to its fair meaning. Any presumption or principle that the language is to be construed against any party shall not apply. The headings in this Agreement are only for convenience and are not intended to affect construction or interpretation. Any references to paragraphs, subparagraphs, sections, or subsections are to those parts of this Agreement, unless the context clearly indicates to the contrary. Also, unless the context clearly indicates to the contrary: (a) the plural includes the singular, and the singular includes the plural; (b) “and” and “or” are each used both conjunctively and disjunctively; (c) “any,” “all,” “each,” or “every” means “any and all,” and “each and every”; (d) “includes” and “including” are each “without limitation”; and (e) “herein,” “hereof,” “hereunder,” and other similar compounds of the word “here” refer to the entire Agreement and not to any particular paragraph, subparagraph, section, or subsection.



**21. Dispute Resolution.** The parties agree that any suit, action or proceeding brought by or against such party in connection with this Agreement shall be brought solely in any state or federal court within the State of Delaware. Each party expressly and irrevocably consents and submits to the jurisdiction and venue of each such court in connection with any such legal proceeding, including to enforce any settlement, order or award, and such party agrees to accept service of process by the other party or any of its agents in connection with any such proceeding. EACH PARTY HEREBY IRREVOCABLY WAIVES ALL RIGHT TO A TRIAL BY JURY IN ANY SUIT, ACTION OR OTHER PROCEEDING INSTITUTED BY OR AGAINST SUCH PARTY IN RESPECT OF ITS RIGHTS OR OBLIGATIONS HEREUNDER.

**22. Enforcement.** If any provision of this Agreement is held to be illegal, invalid, or unenforceable under present or future laws effective during the term of this Agreement, such provision shall be fully severable, this Agreement shall be construed and enforced as if such illegal, invalid, or unenforceable provision were never a part of this Agreement, and the remaining provisions of this Agreement shall remain in full force and effect and shall not be affected by the illegal, invalid, or unenforceable provision or by its severance from this Agreement. Furthermore, in lieu of such illegal, invalid, or unenforceable provision, there shall be added automatically as part of this Agreement a provision as similar in terms to such illegal, invalid, or unenforceable provision as may be possible and be legal, valid, and enforceable.

**23. Withholding.** The Company shall be entitled to withhold from any amounts payable under this Agreement any federal, state, local, and foreign withholding and other taxes and charges that the Company is required to withhold. The Company shall be entitled to rely on an opinion of counsel if any questions as to the amount or requirement of withholding shall arise.

**24. Employee Representations.** The Executive represents, warrants and covenants that (i) that he has read and understands this Agreement, is fully aware of its legal effect, has not acted in reliance upon any representations or promises made by the Company other than those contained in writing herein, and has entered into this Agreement freely based on his own judgment, (ii) Executive has the full right, authority and capacity to enter into this Agreement and perform Executive's obligations hereunder, (iii) Executive is not bound by any agreement that conflicts with or prevents or restricts the full performance of Executive's duties and obligations to the Company hereunder during or after the Term, (iv) the execution and delivery of this Agreement shall not result in any breach or violation of, or a default under, any existing obligation, commitment or agreement to which Executive is subject, and (v) the Executive shall keep all terms of this Agreement confidential, except with respect to disclosure to the Executive's spouse, accountants or attorneys, each of whom shall agree to keep all terms of this Agreement confidential. Prior to execution of this Agreement, the Executive was advised by the Company of the Executive's right to seek independent advice from an attorney of the Executive's own selection regarding this Agreement. The Executive acknowledges that the Executive has entered into this Agreement knowingly and voluntarily and with full knowledge and understanding of the provisions of this Agreement after being given the opportunity to consult with counsel. The Executive further represents that in entering into this Agreement, Executive is not relying on any statements or representations made by any of the Company's directors, officers, employees or agents that are not expressly set forth herein, and that the Executive is relying only upon Executive's own judgment and any advice provided by Executive's attorney.

**25. Condition Precedent.** This Agreement will become effective subject to and conditioned upon the occurrence of the Closing (as defined in the MIPA). This Agreement shall automatically terminate without any action on the part of any person and be void ab initio if the MIPA is terminated in accordance with its terms or the transactions contemplated thereunder are otherwise abandoned, and neither the Company, Apollo nor any other Person shall have any liability to the Executive under this Agreement if the Closing does not occur.

*[signature page follows]*

The parties have executed this Agreement as of the date first written above.

**MN AIRLINES, LLC**

By: /s/ Jude Bricker

\_\_\_\_\_  
Name: Jude I. Bricker

Title: President and CEO

**EXECUTIVE**

/s/ David Davis

\_\_\_\_\_  
David Davis

## EMPLOYMENT AGREEMENT

This Employment Agreement (this “Agreement”), entered into on July 1, 2019, is made by and between Gregory A. Mays (the “Executive”) and Sun Country, Inc, a Minnesota corporation (together with any of its subsidiaries and Affiliates (as defined below) as may employ the Executive from time to time, and any and all successors thereto, the “Company”).

### RECITALS

A. The Company and Executive desire to enter into this Agreement to assure the Company of the exclusive services of the Executive and to set forth the rights and duties of the parties hereto.

B. This Agreement shall supersede any prior agreements or understandings, whether formal or informal, between Executive and the Company or any of its Affiliates.

### AGREEMENT

NOW, THEREFORE, in consideration of the foregoing and of the respective covenants and agreements set forth below, the parties hereto agree as follows:

1. Certain Definitions.

(a) “Action” shall have the meaning set forth in Section 9.

(b) “Affiliate” shall mean, with respect to any Person, any other Person directly or indirectly controlling, controlled by, or under common control with such Person, where “control” shall have the meaning given such term under Rule 405 of the Securities Act of 1933, as amended.

(c) “Agreement” shall have the meaning set forth in the preamble hereto.

(d) “Annual Base Salary” shall have the meaning set forth in Section 3(a).

(e) “Annual Bonus” shall have the meaning set forth in Section 3(b).

(f) “Apollo” means, collectively, the investment funds managed, sponsored or advised by Apollo Management VIII, L.P. A reference to a member of Apollo is a reference to any such investment fund.

(g) “Board” shall mean the Board of Directors of the Company.

(h) The Company shall have “Cause” to terminate the Executive’s employment pursuant to Section 4(a)(iii) hereunder upon (i) the Executive’s indictment for, conviction of, or plea of guilty or nolo contendere to, any (x) felony, (y) misdemeanor involving moral turpitude, or (z) other crime involving either fraud or a breach of the Executive’s duty of loyalty with respect to the Company or any Affiliates thereof, or any of its customers or suppliers, (ii) the Executive’s failure to perform duties as reasonably directed by the Board (other than as a

consequence of Disability) after written notice thereof and failure to cure within ten (10) business days of receipt of the written notice, (iii) the Executive's fraud, misappropriation, embezzlement (whether or not in connection with employment), or material misuse of funds or property belonging to the Company or any of its Affiliates, (iv) the Executive's willful violation of the policies of the Company or any of its subsidiaries, or gross negligence in connection with the performance of his duties, after written notice thereof and failure to cure within ten (10) business days of receipt of written notice, (v) the Executive's use of alcohol that interferes with the performance of the Executive's duties or use of illegal drugs, if either (A) the Executive fails to obtain treatment within ten (10) business days after receipt of written notice thereof or (B) the Executive obtains treatment and, following Executive's return to work, the Executive's use of alcohol again interferes with the performance of the Executive's duties or the Executive again uses illegal drugs, (vi) the Executive's material breach of this Agreement, and failure to cure such breach within ten (10) business days after receipt of written notice, or (vii) the Executive's breach of the confidentiality or non-disparagement provisions (excluding unintentional breaches that are cured within ten (10) days after the Executive becomes aware of such breaches, to the extent curable) or the non-competition and non-solicitation provisions to which the Executive is subject (including, without limitation, under Sections 6 and 7 of this Agreement)]. If, within thirty (30) days subsequent to the Executive's termination of employment for any reason other than by the Company for Cause, the Company discovers facts such that the Executive's termination of employment could have been for Cause, the Executive's termination of employment will be deemed to have been for Cause for all purposes, and the Executive will be required to disgorge to the Company all amounts received under this Agreement, all equity awards or otherwise that would not have been payable to the Executive had such termination of employment been by the Company for Cause.

(i) "Code" shall mean the Internal Revenue Code of 1986, as amended.

(j) "Date of Termination" shall mean (i) if the Executive's employment is terminated by his death, the date of his death, (ii) if the Executive's employment is terminated pursuant to Section 4(a)(ii)-(v), the date specified or otherwise effective pursuant to Section 4(a)(v), or (iii) if the Executive's employment is terminated upon expiration of the Term due to either party's non-renewal in accordance with Section 2(b), the last day of the then-current Term.

(k) "Disability" shall mean the Executive's incapacitation through any illness, injury, accident or condition of either a physical or psychological nature that has resulted in his inability to perform the essential functions of his position, even with reasonable accommodations, for one hundred eighty (180) calendar days during any period of three hundred sixty-five (365) consecutive calendar days, and such incapacity is expected to continue, as determined by an independent medical examination and evaluated in accordance with the standard used under the Company's long-term disability insurance policy.

(l) "Executive" shall have the meaning set forth in the preamble hereto.

(m) "Inventions" shall have the meaning set forth in Section 7(c)(i).

(n) "Notice of Termination" shall have the meaning set forth in Section 4(a)(v).

(o) “Person” shall mean an individual, partnership, corporation, limited liability company, business trust, joint stock company, trust, unincorporated association, joint venture, governmental authority, or other entity of whatever nature.

(p) “Proprietary Rights” shall have the meaning set forth in Section 7(c)(i).

(q) “Term” shall have the meaning set forth in Section 2(b).

2. Employment.

(a) In General. The Company shall employ the Executive, and the Executive shall be employed by the Company, for the period set forth in Section 2(b), in the position set forth in Section 2(c), and upon the other terms and conditions herein provided.

(b) Term of Employment. The initial term of employment under this Agreement (the “Initial Term”) shall be for the period beginning on June 3, 2019 (the “Effective Date”) and ending on the fifth (5<sup>th</sup>) anniversary of such date, unless terminated earlier as provided in Section 4. The Initial Term shall automatically be extended for successive one (1) year periods (together with the Initial Term, the “Term”), unless either party hereto gives notice of the non-extension of the Term to the other party no later than ninety (90) days prior to the expiration of the then-applicable Term.

(c) Position and Duties.

(i) During the Term, the Executive shall serve as Chief Operating Officer of the Company, with responsibilities, duties, and authority customary for such position. The Executive shall report to the Chief Executive Officer of the Company. The Executive agrees to observe and comply with the Company’s rules and policies as adopted from time to time by the Company. The Executive shall devote his full business time, skill, attention, and best efforts to the performance of his duties hereunder; provided, however, that the Executive shall be entitled to (A) serve on civic, charitable, and religious boards, (B) subject in each case to approval by the Board, serve on corporate boards, and (C) manage the Executive’s personal and family investments, in each case, to the extent that such activities do not interfere with the performance of the Executive’s duties and responsibilities hereunder, are not in conflict with the business interests of the Company or its Affiliates, and do not compete with the business of the Company or its Affiliates. During the Term, the Executive shall submit to the Board all business, commercial and investment opportunities or offers presented to the Executive or of which the Executive becomes aware which relate to the business of the Company and its Affiliates at any time during the Term, and unless approved by the Board, the Executive shall not accept or pursue, directly or indirectly, any such corporate opportunities on the Executive’s own behalf.

(ii) The Executive’s employment shall be principally based at the Company’s headquarters in the Minneapolis, Minnesota area. The Executive shall perform his duties and responsibilities to the Company at such principal place of employment and at such other location(s) to which the Company may reasonably require the Executive to travel for Company business purposes.

3. Compensation and Related Matters.

(a) Annual Base Salary. Executive's Annual Base Salary shall be three hundred thousand dollars (\$300,000) per annum, payable semi-monthly in accordance with the Company's payroll practices. The Board may review Executive's Annual Base Salary for increase or decrease from time to time in its sole discretion.

(b) Annual Bonus. Executive shall be eligible to receive a discretionary annual cash bonus with a target amount equal to seventy-five percent (75%) of the applicable Annual Base Salary (the "Annual Bonus"). The Executive's actual Annual Bonus for a given year, if any, shall be determined on the basis of the Executive's and/or the Company's attainment of objective financial and/or other subjective or objective criteria established by the Board and communicated to the Executive at the beginning of such year. Each such Annual Bonus shall be payable on such date as is determined by the Board, but in any event within the period required by Section 409A of the Code such that it qualifies as a "short-term deferral" pursuant to Section 1.409A-1(b) (4) of the Department of Treasury Regulations (or any successor thereto). No Annual Bonus shall be payable with respect to any calendar year unless the Executive remains continuously employed with the Company through the date of payment, except as otherwise provided herein or in Section 5.

(c) Equity. As soon as reasonably practicable following the Effective Date, the Executive shall be granted an option to purchase shares of common stock of SCA Acquisition Holdings, LLC equal to 1.0% of the fully diluted total outstanding shares of SCA Acquisition Holdings, LLC as of the date of grant (the "Option"), subject to the terms and conditions set forth in the Company's equity incentive plan (the "Equity Plan") and a nonqualified stock option agreement thereunder.

(d) Executive Travel Benefits. The Executive is entitled to both positive-space and space-available travel benefits, in accordance with the Company's rules and policies.

(i) Positive Space Travel. Positive space travel is permitted as follows: the Executive will receive an annual credit of \$12,500 in the Executive's Universal Air Travel Plan ("UATP") account for personal travel on Company scheduled flights for the Executive and certain Qualifying Friends and Family (as defined below). Each flown segment is valued at \$75. and deducted from the UATP account. The value of this benefit is reported as taxable income with taxes on such income paid for by the Company.

(ii) Qualifying Friends & Family. "Qualifying Friends and Family" are defined as follows:

(A) If the Executive travels on a flight itinerary, the Executive may bring up to eight friends or family members, on the same itinerary, on any scheduled Company flight (provided such persons are not prohibited by Company from traveling on Company flights).

(B) If the Eligible Executive is not listed on the flight itinerary, i) the Executive's Circle Of Travelers (defined under the Company's Employee Travel Policy) may use the Executive's positive travel benefit for any scheduled Company flight and flown segments will be deducted from the UATP account; or

ii) any friend or family member not otherwise prohibited by Company from traveling on Company's flights, may travel to and/or from the Executive's then-present location or homestead, to visit the Executive and/or Executive's family.

(iii) Space Available Travel. The Executive and the Executive's Circle Of Travelers may also travel on scheduled Company flights in accordance with the Company's Employee Travel Policy, in which case, flown segments will not be deducted from the Executive's UATP account.

(iv) Vesting. Upon the earlier of (x) five (5) years from June 3, 2019, or (y) a Change in Control (as defined in the Equity Plan), Executive's travel benefits under this Section 3(d) shall vest for the Executive's lifetime and therefore be useable by Executive for the remainder of Executive's life. The terms related to the Company's policies shall be defined as the terms were defined the day before the execution of any agreement or event that would trigger the vesting described here.

(e) Benefits. During the Term, the Executive shall be entitled to participate in the employee benefit plans, programs, and arrangements of the Company as generally made available to similarly situated executives, and as may be in effect from time to time, in accordance with their terms.

(f) Vacation. During the Term, the Executive shall be entitled to twenty days of vacation in accordance with the Company's vacation policies, as then in effect. Any vacation shall be taken at a time that does not unreasonably interfere with the Executive's work and the Company's operations.

(g) Business Expenses. During the Term, the Company shall reimburse the Executive for all reasonable travel and other business expenses incurred by him in the performance of his duties to the Company, in accordance with the Company's expense reimbursement policies and procedures.

(h) Relocation. The Executive shall receive a relocation bonus for relocation to the Minneapolis, Minnesota area, in the amount of \$52,000, payable in accordance with the Company's normal payroll practices: provided, however, if the Executive resigns from employment for any reason prior to the twenty-four month period after the Effective Date, then he shall repay to the Company within thirty (30) days of the date of termination a prorated portion of the relocation bonus with the amount of such prorated portion equal to (i) the Relocation Bonus, multiplied by (ii) a fraction, (x) the numerator of which is equal to 730 minus the number of calendar days from the Effective Date and (y) the denominator of which is 730. To the extent that the Executive is required to recognize any such relocation bonus as taxable income, the Company shall provide the Executive with an additional make-whole payment intended to place the Executive in the same after-tax position that the Executive would have been in had the Executive not recognized such amounts as taxable income. Each such make-whole payment shall be calculated and paid in accordance with the Company's customary practices for payments of this type, as in effect from time to time.



4. Termination. Prior to the expiration of the Term resulting from a non-renewal pursuant to Section 2(b) above, the Executive's employment hereunder may be terminated without any breach of this Agreement only under the following circumstances:

(a) Circumstances.

(i) Death. The Executive's employment hereunder shall terminate upon his death.

(ii) Disability. If the Executive has incurred a Disability, the Company may give the Executive written notice of its intention to terminate the Executive's employment. In that event, the Executive's employment with the Company shall terminate effective on the later of the thirtieth (30<sup>th</sup>) day after receipt of such notice by the Executive and the date specified in such notice, provided that within the thirty (30) day period following receipt of such notice, the Executive shall not have returned to full-time performance of his duties hereunder.

(iii) Termination with Cause. The Company may terminate the Executive's employment with Cause.

(iv) Termination without Cause. The Company may terminate the Executive's employment without Cause.

(v) Resignation. The Executive may resign from his employment upon not less than sixty (60) days' advance written notice to the Board.

(b) Notice of Termination. Any termination of the Executive's employment by the Company or by the Executive under this Section 4 (other than termination pursuant to Section 4(a)(i)) shall be communicated by a written notice to the other party hereto (i) indicating the specific termination provision in this Agreement relied upon, (ii) except with respect to a termination pursuant to Section 4(a)(iv), setting forth in reasonable detail the facts and circumstances claimed to provide a basis for termination of the Executive's employment under the provision so indicated, and (iii) specifying a Date of Termination as provided herein (a "Notice of Termination"). If the Company delivers a Notice of Termination under Section 4(a)(ii), the Date of Termination shall be at least sixty (60) days following the date of such notice; provided, however, that such notice need not specify a Date of Termination, in which case the Date of Termination shall be determined pursuant to Section 4(a)(ii). If the Company delivers a Notice of Termination under Section 4(a)(iii) or 4(a)(iv), the Date of Termination shall be, in the Company's sole discretion, the date on which the Executive receives such notice or any subsequent date selected by the Company. If the Executive delivers a Notice of Termination under Section (a)(v), the Date of Termination shall be at least sixty (60) days following the date of such notice; provided, however, in each case, that the Company may, in its sole discretion, accelerate the Date of Termination to any date that occurs following the Company's receipt of such notice, without changing the characterization of such termination as voluntary, even if such date is prior to the date specified in such notice and without having to pay any compensation or benefits for the balance of such notice period. The failure by the Company to set forth in the Notice of Termination any fact or circumstance that contributes to a showing of Cause shall not waive any right of the Company hereunder or preclude the Company from asserting such fact or circumstance in enforcing the Company's rights hereunder.

(c) Termination of All Positions. Upon termination of the Executive's employment for any reason, the Executive agrees to resign, as of the Date of Termination or such other date requested by the Company, from all positions and offices that the Executive then holds with the Company and its Affiliates. The Executive agrees to promptly execute such documents as the Company, in its sole discretion, shall reasonably deem necessary to effect such resignations, and in the event that the Executive is unable or unwilling to execute any such document, Executive hereby grants his proxy to any officer of the Company to so execute on his behalf.

(d) Suspension of Duties. The Company reserves the right to bar the Executive from the offices of the Company or any of its Affiliates and to require that the Executive refrain from undertaking all or any of the Executive's duties and contacting clients, colleagues and advisors of the Company or any of its Affiliates (unless otherwise instructed) during all or part of any period of notice of Executive's termination of employment. Should the Company exercise this right, all the Executive's other duties and obligations hereunder, including the Executive's duties of fidelity and confidentiality to the Company, remain in full force and effect and, during any such period, the Executive shall remain a service provider to the Company and shall not be employed or engaged in any other business. For the avoidance of doubt, the Company shall continue to pay to the Executive the Annual Base Salary and to provide health and welfare benefits during any such notice period, until the Date of Termination.

5. Company Obligations upon Termination of Employment.

(a) In General. Subject to Section 10(a), upon termination of the Executive's employment for any reason, the Executive (or the Executive's estate) shall be entitled to receive (i) any amount of the Executive's Annual Base Salary earned through the Date of Termination not theretofore paid, (ii) any Annual Bonus for the year prior to the year in which the Date of Termination occurred, that was earned but not yet paid, (iii) any expenses owed to the Executive under Section 3(g), and (iv) any amount arising from the Executive's participation in, or benefits under, any employee benefit plans, programs, or arrangements under Section 3(e) (other than severance plans, programs, or arrangements), which amounts shall be payable in accordance with the terms and conditions of such employee benefit plans, programs, or arrangements including, where applicable, any death and disability benefits (the "Accrued Obligations"). Notwithstanding anything to the contrary, upon a termination by the Company with Cause, the Accrued Obligations shall not include the amount set forth in clause (ii) of the preceding sentence.

(b) Termination without Cause. Subject to Section 10(a) and subject to the Executive's continued compliance with the covenants contained in Sections 6 and 7, if the Company terminates the Executive's employment without Cause pursuant to Section 4(a)(iv), the Company shall, in addition to the Accrued Obligations, continue to pay the Annual Base Salary in accordance with the Company's customary payroll practices during the period beginning on the Date of Termination and ending on the earlier to occur of (A) the twelve (12) month anniversary of the Date of Termination and (B) the first date that the Executive violates any covenant contained in Section 6 or 7, after receipt of written notice thereof and expiration of a 10

business day cure period; provided, however, the installment payments payable pursuant to this Section 5(b) shall commence on the first payroll period following the effective date of the Release (as defined below), and the initial installment shall include a lump-sum payment of all amounts accrued under this Section 5(b) from the Date of Termination through the date of such initial payment.

(c) Release. Notwithstanding anything herein to the contrary, the amounts payable to the Executive under Sections 5(b), other than the Accrued Obligations, shall be contingent upon and subject to the Executive's (or the Executive's estate, if applicable) execution and non- revocation of a general waiver and release of claims agreement in the Company's customary form (the "Release") (and the expiration of any applicable revocation period), on or prior to the sixtieth (60<sup>th</sup>) day following the Date of Termination.

(d) Survival. The expiration or termination of the Term shall not impair the rights or obligations of any party hereto, which shall have accrued prior to such expiration or termination.

6. Non-Competition; Non-Solicitation; Non-Hire.

(a) To the fullest extent permitted by applicable law, the Executive agrees that during the Executive's employment with the Company, and for the twelve (12) month period following the Executive's termination of employment for any reason, the Executive will not, directly or indirectly, engage in, have any equity or equity-based interest in, or manage or operate any Person, firm, corporation, partnership, business or entity (whether as director, officer, employee, agent, representative, partner, security holder, consultant, or otherwise) that engages in (either directly or through any subsidiary or Affiliate thereof) any business or activity that competes with any of the businesses of the Company or any entity owned by the Company (including, without limitation, any United States regional air carrier or any non-mainline carrier in Mexico, Canada or the Caribbean). Notwithstanding the foregoing, the Executive shall be permitted to acquire a passive stock or equity interest in such a business, provided that the stock or other equity interest acquired is not more than one percent (1%) of the outstanding interest in such business;

(b) To the fullest extent permitted by applicable law, the Executive agrees that during the Executive's employment with the Company, and for the twelve (12) month period following the Executive's termination of employment for any reason, the Executive will not, directly or indirectly, on the Executive's own behalf or on behalf of another (i) solicit, induce or attempt to solicit or induce any officer, director or employee of the Company to terminate their relationship with or leave the employ of the Company, or in any way interfere with the relationship between the Company, on the one hand, and any officer, director or employee thereof, on the other hand, (ii) hire (or other similar arrangement) any Person (in any capacity whether as an officer, director, employee or consultant) who is or at any time was an officer, director or employee of the Company until twelve (12) months after such individual's relationship (whether as an officer, director or employee) with the Company has ended, or (iii) induce or attempt to induce any customer, supplier, prospect, licensee or other business relation of the Company to cease doing business with the Company, or in any way interfere with the relationship between any such customer, supplier, prospect, licensee or business relation, on the one hand, and the Company, on the other hand; provided, that it shall not be a violation of this Section 6(b) for a subsequent

employer of the Executive to hire a Company employee who is at the “director” level or below, so long as such Company employee responds to generic, non-targeted position advertising and the Executive does not engage in activities prohibited by clause (i) of this Section 6(b) with respect to such Company employee.

(c) In the event that the terms of this Section 6 shall be determined by any court of competent jurisdiction to be unenforceable by reason of its extending for too great a period of time or over too great a geographical area or by reason of its being too extensive in any other respect, it will be interpreted to extend only over the maximum period of time for which it may be enforceable, over the maximum geographical area as to which it may be enforceable, or to the maximum extent in all other respects as to which it may be enforceable, all as determined by such court in such action. The Executive hereby acknowledges that the terms of this Section 6 are reasonable in terms of duration, scope and area restrictions and are necessary to protect the goodwill of the Company. The Executive hereby authorizes the Company to inform any future employer or prospective employer of the existence and terms of Sections 6 and 7 of this Agreement without liability for interference with the Executive’s employment or prospective employment.

(d) The Executive acknowledges that the Company has expended and shall continue to expend substantial amounts of time, money and effort to develop business strategies, employee and customer relationships and goodwill and build an effective organization. The Executive recognizes and acknowledges that he has access to confidential information and trade secrets, and has had or will have material contact with the Company’s customers, suppliers, licensees, representatives, agents, partners, licensors, or business relations, and that the Executive’s services are of special, unique and extraordinary value to the Company and its Affiliates. The Executive acknowledges that the Company has a legitimate business interest and right in protecting its confidential information, business strategies, employee and customer relationships and goodwill, and that the Company would be seriously damaged by the disclosure of confidential information and the loss or deterioration of its business strategies, employee and customer relationships and goodwill. The Executive acknowledges (i) that the business of the Company and its Affiliates is international in scope and without geographical limitation and (ii) notwithstanding the jurisdiction of formation or principal office of the Company and its Affiliates, or the location of any of their respective executives or employees (including, without limitation, the Executive), it is expected that the Company and its Affiliates will have business activities and have valuable business relationships within their respective industries throughout the world. The Executive further acknowledges that although his compliance with the covenants contained in Sections 6 and 7 may prevent the Executive from earning a livelihood in a business similar to the business of the Company, the Executive’s experience and capabilities are such that the Executive has other opportunities to earn a livelihood and adequate means of support for the Executive and the Executive’s dependents. In addition, the Executive agrees and acknowledges that the potential harm to the Company of the non-enforcement of Sections 6 and 7 outweighs any potential harm to the Executive of their enforcement by injunction or otherwise.

(e) As used in this Section 6, the term “Company” shall include the Company, and any direct or indirect subsidiaries thereof or any successors thereto.

7. Nondisclosure of Confidential Information; Nondisparagement; Intellectual Property.

(a) Non-Disclosure of Confidential Information; Return of Property. Except as required in the faithful performance of the Executive's duties hereunder, Executive agrees that during the Term and in perpetuity thereafter, the Executive shall maintain in confidence and shall not directly, indirectly or otherwise, use, disseminate, disclose or publish, or use for the Executive's benefit or the benefit of any Person, any confidential or proprietary information or trade secrets of or relating to the Company, including, without limitation, information with respect to the Company's operations, processes, products, inventions, business practices, finances, principals, vendors, suppliers, customers, potential customers, marketing methods, costs, prices, contractual relationships, regulatory status, compensation paid to employees or other terms of employment, or deliver to any Person any document, record, notebook, computer program or similar repository of or containing any such confidential or proprietary information or trade secrets. Confidential Information shall not include any information that is generally known to the industry or the public other than as a result of the Executive's breach of this covenant or any breach of other confidentiality obligations by third parties. Upon the Executive's termination of employment for any reason, the Executive shall promptly deliver to the Company all correspondence, drawings, manuals, letters, notes, notebooks, reports, programs, plans, proposals, financial documents, or any other documents concerning the Company's customers, business plans, marketing strategies, products or processes. The Executive may respond to a lawful and valid subpoena or other legal process but shall give the Company the earliest possible notice thereof, shall, as much in advance of the return date as possible, make available to the Company and its counsel the documents and other information sought and, if requested by the Company, shall reasonably assist such counsel in resisting or otherwise responding to such process.

(b) Non-Disparagement. The Executive shall not, at any time during the Term and in perpetuity thereafter, directly or indirectly, knowingly disparage, criticize, or otherwise make derogatory statements regarding the Company and its officers, the members of the Board, and the respective Affiliates of any of the foregoing. The foregoing shall not be violated by the Executive's truthful responses to legal process or inquiry by a governmental authority.

(c) Intellectual Property Rights.

(i) The Executive agrees that the results and proceeds of the Executive's services for the Company (including, but not limited to, any trade secrets, products, services, processes, know-how, designs, developments, innovations, analyses, drawings, reports, techniques, formulas, methods, developmental or experimental work, improvements, discoveries, inventions, ideas, source and object codes, programs, matters of a literary, musical, dramatic or otherwise creative nature, writings and other works of authorship) resulting from services performed for the Company and any works in progress, whether or not patentable or registrable under copyright or similar statutes, that were made, developed, conceived or reduced to practice or learned by the Executive, either alone or jointly with others (collectively, "Inventions"), shall be works-made-for-hire and the Company (or, if applicable or as directed by the Company) shall be deemed the sole owner throughout the universe of any and all trade secret, patent, copyright and other intellectual property rights (collectively, "Proprietary Rights") of whatsoever nature therein, whether or not now or hereafter known, existing, contemplated, recognized or developed, with the right to use the same in perpetuity in any manner the Company determines in its sole discretion, without any further payment to the Executive whatsoever. If, for any reason,

any of such results and proceeds shall not legally be a work-made-for-hire and/or there are any Proprietary Rights which do not accrue to the Company under the immediately preceding sentence, then the Executive hereby irrevocably assigns and agrees to assign any and all of the Executive's right, title and interest thereto, including, without limitation, any and all Proprietary Rights of whatsoever nature therein, whether or not now or hereafter known, existing, contemplated, recognized or developed, to the Company (or, if applicable or as directed by the Company, any of its Affiliates), and the Company or such Affiliates shall have the right to use the same in perpetuity throughout the universe in any manner determined by the Company or such Affiliates without any further payment to the Executive whatsoever. As to any Invention that the Executive is required to assign, the Executive shall promptly and fully disclose to the Company all information known to the Executive concerning such Invention. The Executive hereby waives and quitclaims to the Company any and all claims, of any nature whatsoever, that the Executive now or may hereafter have for infringement of any Proprietary Rights assigned hereunder to the Company. In accordance with applicable law, this section 7(c) does not apply to any Inventions for which no equipment, supplies, facilities, trade secrets or other Confidential Information of the Company was used and which was developed entirely on the Executive's own time unless (a) the Invention relates to the Company's business or the Company's actual or demonstrably anticipated research or development; or (b) the Invention results from any work performed by the Executive for the Company.

(ii) The Executive agrees that, from time to time, as may be requested by the Company and at the Company's sole cost and expense, the Executive shall do any and all things that the Company may reasonably deem useful or desirable to establish or document the Company's exclusive ownership throughout the United States of America or any other country of any and all Proprietary Rights in any such Inventions, including, without limitation, the execution of appropriate copyright and/or patent applications or assignments. To the extent the Executive has any Proprietary Rights in the Inventions that cannot be assigned in the manner described above, the Executive unconditionally and irrevocably waives the enforcement of such Proprietary Rights. This Section 7(c)(ii) is subject to and shall not be deemed to limit, restrict or constitute any waiver by the Company of any Proprietary Rights of ownership to which the Company may be entitled by operation of law by virtue of the Executive's employment with, or service to, the Company. The Executive further agrees that, from time to time, as may be requested by the Company and at the Company's sole cost and expense, the Executive shall assist the Company in every proper and lawful way to obtain and from time to time enforce Proprietary Rights relating to Inventions in any and all countries. To this end, the Executive shall execute, verify and deliver such documents and perform such other acts (including appearances as a witness) as the Company may reasonably request for use in applying for, obtaining, perfecting, evidencing, sustaining, and enforcing such Proprietary Rights and the assignment thereof. In addition, the Executive shall execute, verify, and deliver assignments of such Proprietary Rights to the Company or its designees. The Executive's obligation to assist the Company with respect to Proprietary Rights relating to such Inventions in any and all countries shall continue beyond the termination of the Executive's employment with the Company.

(d) Prior Employment Information. The Executive further agrees that the Executive will not improperly use or disclose any confidential information or trade secrets, if any, of any former employers or any other Person to whom the Executive has an obligation of confidentiality, and will not bring onto the premises of the Company or its Affiliates any

unpublished documents or any property belonging to any former employer or any other Person to whom the Executive has an obligation of confidentiality unless consented to in writing by the former employer or other Person.

(e) Notwithstanding anything to the contrary contained in this Agreement, (i) the Executive will not be held criminally or civilly liable under any federal or state trade secret law for any disclosure of a trade secret that is made: (A) in confidence to a federal, state, or local government official, either directly or indirectly, or to an attorney; and (B) solely for the purpose of reporting or investigating a suspected violation of law; or is made in a complaint or other document that is filed under seal in a lawsuit or other proceeding, and (ii) nothing in this Agreement shall prohibit Executive from reporting possible violations of federal law or regulation to or otherwise cooperating with or providing information requested by any governmental agency or entity, including, but not limited to, the Department of Justice, the Securities and Exchange Commission, the Congress, and any agency Inspector General, or making other disclosures that are protected under the whistleblower provisions of federal law or regulation. The Executive does not need the prior authorization of the Company to make any such reports or disclosures and the Executive is not required to notify the Company that the Executive has made such reports or disclosures. If the Executive files a lawsuit for retaliation by the Company for reporting a suspected violation of law, the Executive may disclose the Company's trade secrets to the Executive's attorney and use the trade secret information in the court proceeding if the Executive: (x) files any document containing the trade secret under seal; and (y) does not disclose the trade secret, except pursuant to court order.

(f) As used in this Section 7, the term "Company" shall include the Company, and any direct or indirect subsidiaries thereof or any successors thereto.

8. Injunctive Relief. The Executive recognizes and acknowledges that a breach of any of the covenants contained in Sections 6 and 7 may cause irreparable damage to the Company and its goodwill, the exact amount of which may be difficult or impossible to ascertain, and that the remedies at law for any such breach may be inadequate. Accordingly, the Executive agrees that in the event of a breach or threatened breach of any of the covenants contained in Sections 6 and 7, in addition to any other remedy that may be available at law or in equity, the Company will be entitled (without the necessity of showing economic loss or other actual damage) to specific performance and injunctive relief (without posting a bond). In the event of any breach or violation by the Executive of any of the covenants contained in Section 6 and 7, the time period of such covenant with respect to the Executive shall, to the fullest extent permitted by law, be tolled until such breach or violation is resolved.

9. Cooperation. The Executive agrees that during and after his employment with the Company, the Executive will assist the Company and its Affiliates in the defense of any claims or potential claims that may be made or threatened to be made against the Company or any of its Affiliates in any action, suit, or proceeding, whether civil, criminal, administrative, investigative, or otherwise (each, an "Action"), and will assist the Company and its Affiliates in the prosecution of any claims that may be made by the Company or any of its Affiliates in any Action, to the extent that such claims may relate to the Executive's employment or the period of the Executive's employment by the company and its Affiliates. The Executive agrees, unless precluded by law, to promptly inform the Company if the Executive is asked to participate (or

otherwise become involved) in any such Action. The Executive also agrees, unless precluded by law, to promptly inform the Company if the Executive is asked to assist in any investigation (whether governmental or otherwise) of the Company or any of its Affiliates (or their actions) to the extent that such investigation may relate to the Executive's employment or the period of the Executive's employment by the Company, regardless of whether a lawsuit has then been filed against the Company or any of its Affiliates with respect to such investigation. The Company or one of its Affiliates shall pay Executive a reasonable hourly rate and reimburse the Executive for all of the Executive's reasonable out-of-pocket expenses associated with such cooperation following his Date of Termination.

10. Section 409A of the Code.

(a) General. The parties hereto acknowledge and agree that, to the extent applicable, this Agreement shall be interpreted in accordance with, and incorporate the terms and conditions required by, Section 409A of the Code and the Department of Treasury Regulations and other interpretive guidance issued thereunder, including without limitation any such regulations or other guidance that may be issued after the date hereof. Notwithstanding any provision of this Agreement to the contrary, in the event that the Company determines that any amounts payable hereunder will be taxable currently to the Executive under Section 409A(a)(1)(A) of the Code and related Department of Treasury guidance, the Company and the Executive shall cooperate in good faith to (i) adopt such amendments to this Agreement and appropriate policies and procedures, including amendments and policies with retroactive effect, that they mutually determine to be necessary or appropriate to preserve the intended tax treatment of the benefits provided by this Agreement, to preserve the economic benefits of this Agreement, and to avoid less-favorable accounting or tax consequences for the Company, and/or (ii) take such other actions as mutually determined to be necessary or appropriate to exempt the amounts payable hereunder from Section 409A of the Code or to comply with the requirements of Section 409A of the Code and thereby avoid the application of penalty taxes thereunder; provided, however, that this Section 10(a) does not create an obligation on the part of the Company to modify this Agreement and does not guarantee that the amounts payable hereunder will not be subject to interest or penalties under Section 409A, and in no event whatsoever shall the Company or any of its Affiliates be liable for any additional tax, interest, or penalties that may be imposed on the Executive as a result of Section 409A of the Code or any damages for failing to comply with Section 409A of the Code.

(b) Separation from Service under Section 409A. Notwithstanding any provision to the contrary in this Agreement: (i) no amount that is "nonqualified deferred compensation" subject to Section 409A of the Code shall be payable pursuant to Section 5 unless the termination of the Executive's employment constitutes a "separation from service" within the meaning of Section 1.409A-1(h) of the Department of Treasury Regulations; (ii) if the Executive is deemed at the time of his separation from service to be a "specified employee" for purposes of Section 409A(a)(2)(B)(i) of the Code, to the extent that delayed commencement of any portion of the termination benefits to which the Executive is entitled under this Agreement (after taking into account all exclusions applicable to such termination benefits under Section 409A), including, without limitation, any portion of the additional compensation awarded pursuant to Section 5, is required in order to avoid a prohibited distribution under Section 409A(a)(2)(B)(i) of the Code, such portion of the Executive's termination benefits shall not be provided to the Executive prior



to the earlier of (A) the expiration of the six-month period measured from the date of the Executive's "separation from service" with the Company (as such term is defined in the Department of Treasury Regulations issued under Section 409A) and (B) the date of the Executive's death; provided, that upon the earlier of such dates, all payments deferred pursuant to this Section 11(b)(ii) shall be paid to the Executive in a lump sum, and any remaining payments due under this Agreement shall be paid as otherwise provided herein; (iii) the determination of whether the Executive is a "specified employee" for purposes of Section 409A(a)(2)(B)(i) of the Code as of the time of his separation from service shall be made by the Company in accordance with the terms of Section 409A of the Code and applicable guidance thereunder (including, without limitation, Section 1.409A-1 (i) of the Department of Treasury Regulations and any successor provision thereto); (iv) for purposes of Section 409A of the Code, the Executive's right to receive installment payments pursuant to Section 5 shall be treated as a right to receive a series of separate and distinct payments; (v) if the sixty day period following the Date of Termination ends in the calendar year following the year that includes the Date of Termination, then payment of any amount that is conditioned upon the execution of the Release and is subject to Section 409A shall not be paid until the first day of the calendar year following the year that includes the Date of Termination, regardless of when the Release is signed; and (vi) to the extent that any reimbursement of expenses or in-kind benefits constitutes "deferred compensation" under Section 409A, such reimbursement or benefit shall be provided no later than December 31 of the year following the year in which the expense was incurred. The amount of expenses reimbursed in one year shall not affect the amount eligible for reimbursement in any subsequent year. The amount of any in-kind benefits provided in one year shall not affect the amount of in-kind benefits provided in any other year. The right to any benefits or reimbursements or in-kind benefits may not be liquidated or exchanged for any other benefit.

11. Section 280G of the Code.

(a) If there is a change of ownership or effective control or change in the ownership of a substantial portion of the assets of a corporation (within the meaning of Section 280G of the Code) and any payment or benefit (including payments and benefits pursuant to this Agreement) that the Executive would receive from the Company or otherwise ("Transaction Payment") would (i) constitute a "parachute payment" within the meaning of Section 280G of the Internal Revenue Code of 1986 (the "Code"), and (ii) but for this sentence, be subject to the excise tax imposed by Section 4999 of the Code (the "Excise Tax"), then the Company shall cause to be determined, before any amounts of the Transaction Payment are paid to the Executive, which of the following two alternative forms of payment would result in the Executive's receipt, on an after-tax basis, of the greater amount of the Transaction Payment notwithstanding that all or some portion of the Transaction Payment may be subject to the Excise Tax: (x) payment in full of the entire amount of the Transaction Payment (a "Full Payment"), or (y) payment of only a part of the Transaction Payment so that the Executive receives the largest payment possible without the imposition of the Excise Tax (a "Reduced Payment"). For purposes of determining whether to make a Full Payment or a Reduced Payment, the Company shall cause to be taken Into account all applicable federal, state and local income and employment taxes and the Excise Tax (all computed at the highest applicable marginal rate, net of the maximum reduction in federal income taxes which could be obtained from a deduction of such state and local taxes). If a Reduced Payment is made, the reduction in payments and/or benefits will occur in the

following order: (1) cash payments (from latest scheduled to earliest scheduled); (2) any equity or equity derivatives that are included under Section 280G of the Code at full value rather than accelerated value (with the highest value reduced first); and (3) any equity or equity derivatives included under Section 280G of the Code at an accelerated value (and not at full value), with the highest value reduced first (as such values are determined under Treasury Regulation Section 1.280G-1, Q&A 24); and (4) any other non-cash benefits (from latest scheduled to earliest scheduled).

(b) Unless the Executive and the Company otherwise agree in writing, any determination required under this section shall be made in writing by the Company's independent public accountants (the "Accountants"), whose determination shall be conclusive and binding upon the Executive and the Company for all purposes. For purposes of making the calculations required by this section, the Accountants may make reasonable assumptions and approximations concerning applicable taxes and may rely on reasonable, good faith interpretations concerning the application of Sections 280G and 4999 of the Code. The Accountants shall provide detailed supporting calculations to the Company and the Executive as requested by the Company or the Executive. The Executive and the Company shall furnish to the Accountants such information and documents as the Accountants may reasonably request in order to make a determination under this section. The Company shall bear all costs the Accountants may reasonably incur in connection with any calculations contemplated by this Section 11(b).

(c) Notwithstanding the foregoing, in the event that no stock of the Company or its Affiliates is readily tradable on an established securities market or otherwise (within the meaning of Section 280G of the Code) at the time of the change in control, the Board may elect to submit to a vote of shareholders for approval the portion of the Transaction Payments that equals and exceeds three times the Executive's "base amount" (within the meaning of Section 280G of the Code) (the "Excess Parachute Payments") in accordance with Treas. Reg. §1.280G-1, and the Executive shall cooperate with such vote of shareholders, including the execution of any required documentation subjecting the Executive's entitlement to all Excess Parachute Payments to such shareholder vote.

12. Assignment and Successors. The Company may assign its rights and obligations under this Agreement to any entity, including any successor to all or substantially all the assets of the Company, by merger or otherwise, and may assign or encumber this Agreement and its rights hereunder as security for indebtedness of the Company and its Affiliates. The Executive may not assign his rights or obligations under this Agreement to any individual or entity. This Agreement shall be binding upon and inure to the benefit of the Company and the Executive and their respective successors, assigns, personnel, legal representatives, executors, administrators, heirs, distributees, devisees, and legatees, as applicable. In the event of the Executive's death following a termination of his employment, all unpaid amounts otherwise due the Executive (including under Section 5) shall be paid to his estate.

13. Governing Law. This Agreement shall be governed, construed, interpreted, and enforced in accordance with the substantive laws of the State of Delaware, without reference to the principles of conflicts of law of Delaware or any other jurisdiction, and where applicable, the laws of the United States.

14. Validity. The invalidity or unenforceability of any provision or provisions of this Agreement shall not affect the validity or enforceability of any other provision of this Agreement, which shall remain in full force and effect.

15. Notices. Any notice, request, claim, demand, document, and other communication hereunder to any party hereto shall be effective upon receipt (or refusal of receipt) and shall be in writing and delivered personally or sent by telex, telecopy, email or sent by nationally recognized overnight courier, or certified or registered mail, postage prepaid, to the following address (or at any other address as any party hereto shall have specified by notice in writing to the other party hereto):

(a) If to the Company, to it at:

Sun Country, Inc.  
c/o Apollo Global Management, LLC  
9 West 57th Street  
43rd Floor  
New York, New York, United States  
10019  
Attention: Antoine Munfakh  
Email: [amunfakh@apollopl.com](mailto:amunfakh@apollopl.com)

with a copy (which shall not constitute notice) to:

Paul, Weiss, Rifkind, Wharton & Garrison LLP  
1285 Avenue of the Americas  
New York, New York 10019  
Fax: (212) 492-0237  
Attention: Brian Finnegan  
Andrew Gaines  
Email: [bfinnegan@paulweiss.com](mailto:bfinnegan@paulweiss.com)  
[againes@paulweiss.com](mailto:againes@paulweiss.com)

(b) If to the Executive, at his most recent address on the payroll records of the Company.

16. Counterparts. This Agreement may be executed in several counterparts, each of which shall be deemed to be an original, but all of which together will constitute one and the same Agreement, and shall become effective when one or more counterparts have been signed by each of the parties and delivered to the other parties.

17. Entire Agreement. The terms of this Agreement (together with any other agreements and instruments contemplated hereby or referred to herein) are intended by the parties hereto to be the final expression of their agreement with respect to the employment of the Executive by the Company and its Affiliates and to supersede any and all prior employment agreements, offer letters, severance agreements and similar agreements, plans, provisions, understandings or arrangements, whether written or oral, and all such prior agreements, plans, provisions,

understandings or arrangements shall be null and void in their entirety and of no further force or effect as of the Effective Date. The parties hereto further intend that this Agreement shall constitute the complete and exclusive statement of its terms and that no extrinsic evidence whatsoever may be introduced in any judicial, administrative, or other legal proceeding to vary the terms of this Agreement.

18. Amendments: Waivers. This Agreement may not be modified, amended, or terminated except by an instrument in writing signed by the Executive and a duly authorized officer of the Company (other than the Executive) that expressly identifies the amended provision of this Agreement. By an instrument in writing similarly executed and similarly identifying the waived compliance, the Executive or a duly authorized officer of the Company may waive compliance by the other party or parties with any provision of this Agreement that such other party was or is obligated to comply with or perform; provided, however, that such waiver shall not operate as a waiver of, or estoppel with respect to, any other or subsequent failure to comply or perform. No failure to exercise and no delay in exercising any right, remedy, or power hereunder shall preclude any other or further exercise of any other right, remedy, or power provided herein or by law or in equity.

19. No Inconsistent Actions. The parties hereto shall not voluntarily undertake or fail to undertake any action or course of action inconsistent with the provisions or essential intent of this Agreement. Furthermore, it is the intent of the parties hereto to act in a fair and reasonable manner with respect to the interpretation and application of the provisions of this Agreement.

20. Construction. This Agreement shall be deemed drafted equally by both of the parties hereto. Its language shall be construed as a whole and according to its fair meaning. Any presumption or principle that the language is to be construed against any party shall not apply. The headings in this Agreement are only for convenience and are not intended to affect construction or interpretation. Any references to paragraphs, subparagraphs, sections, or subsections are to those parts of this Agreement, unless the context clearly indicates to the contrary. Also, unless the context clearly indicates to the contrary: (a) the plural includes the singular, and the singular includes the plural; (b) “and” and “or” are each used both conjunctively and disjunctively; (c) “any,” “all,” “each,” or “every” means “any and all,” and “each and every”; (d) “includes” and “including” are each “without limitation”; and (e) “herein,” “hereof,” “hereunder,” and other similar compounds of the word “here” refer to the entire Agreement and not to any particular paragraph, subparagraph, section, or subsection.

21. Dispute Resolution. The parties agree that any suit, action or proceeding brought by or against such party in connection with this Agreement shall be brought solely in any state or federal court within the State of Delaware. Each party expressly and irrevocably consents and submits to the jurisdiction and venue of each such court in connection with any such legal proceeding, including to enforce any settlement, order or award, and such party agrees to accept service of process by the other party or any of its agents in connection with any such proceeding. EACH PARTY HEREBY IRREVOCABLY WAIVES ALL RIGHT TO A TRIAL BY JURY IN ANY SUIT. ACTION OR OTHER PROCEEDING INSTITUTED BY OR AGAINST SUCH PARTY IN RESPECT OF ITS RIGHTS OR OBLIGATIONS HEREUNDER.

22. **Enforcement.** If any provision of this Agreement is held to be illegal, invalid, or unenforceable under present or future laws effective during the term of this Agreement, such provision shall be fully severable, this Agreement shall be construed and enforced as if such illegal, invalid, or unenforceable provision were never a part of this Agreement, and the remaining provisions of this Agreement shall remain in full force and effect and shall not be affected by the illegal, invalid, or unenforceable provision or by its severance from this Agreement. Furthermore, in lieu of such illegal, invalid, or unenforceable provision, there shall be added automatically as part of this Agreement a provision as similar in terms to such illegal, invalid, or unenforceable provision as may be possible and be legal, valid, and enforceable.

23. **Withholding.** The Company shall be entitled to withhold from any amounts payable under this Agreement any federal, state, local, and foreign withholding and other taxes and charges that the Company is required to withhold. The Company shall be entitled to rely on an opinion of counsel if any questions as to the amount or requirement of withholding shall arise.

24. **Employee Representations.** The Executive represents, warrants and covenants that (i) that he has read and understands this Agreement, is fully aware of its legal effect, has not acted in reliance upon any representations or promises made by the Company other than those contained in writing herein, and has entered into this Agreement freely based on his own judgment, (ii) Executive has the full right, authority and capacity to enter into this Agreement and perform Executive's obligations hereunder, (iii) Executive is not bound by any agreement that conflicts with or prevents or restricts the full performance of Executive's duties and obligations to the Company hereunder during or after the Term, (iv) the execution and delivery of this Agreement shall not result in any breach or violation of, or a default under, any existing obligation, commitment or agreement to which Executive is subject, and (v) the Executive shall keep all terms of this Agreement confidential, except with respect to disclosure to the Executive's spouse, accountants or attorneys, each of whom shall agree to keep all terms of this Agreement confidential. Prior to execution of this Agreement, the Executive was advised by the Company of the Executive's right to seek independent advice from an attorney of the Executive's own selection regarding this Agreement. The Executive acknowledges that the Executive has entered into this Agreement knowingly and voluntarily and with full knowledge and understanding of the provisions of this Agreement after being given the opportunity to consult with counsel. The Executive further represents that in entering into this Agreement, Executive is not relying on any statements or representations made by any of the Company's directors, officers, employees or agents that are not expressly set forth herein, and that the Executive is relying only upon Executive's own judgment and any advice provided by Executive's attorney.

*[signature page follows]*

The parties have executed this Agreement as of the date first written above.

**SUN COUNTRY, INC.**

By: /s/ Jude Bricker

Name: Jude Bricker

Title: President & CEO

**EXECUTIVE**

/s/ Gregory A. Mays

Gregory A. Mays

## SUBSIDIARIES OF SUN COUNTRY AIRLINES HOLDINGS, INC.

<u>Name</u>	<u>Jurisdiction of Incorporation</u>
SCA Acquisition Intermediate, LLC	Delaware
SCA Acquisition, LLC	Delaware
Sun Country, Inc.	Minnesota